



See instruction manual 308981 for important warnings and information.
READ AND KEEP FOR REFERENCE.

INSTRUCTIONS

First choice when quality counts.™

For converting **METAL** Husky 715 air-operated diaphragm pumps

Husky™ 716 Air Motor Retrofit Kits

Part No. 241631

with standard air motor

Part No. 241664

with remote-operated air motor

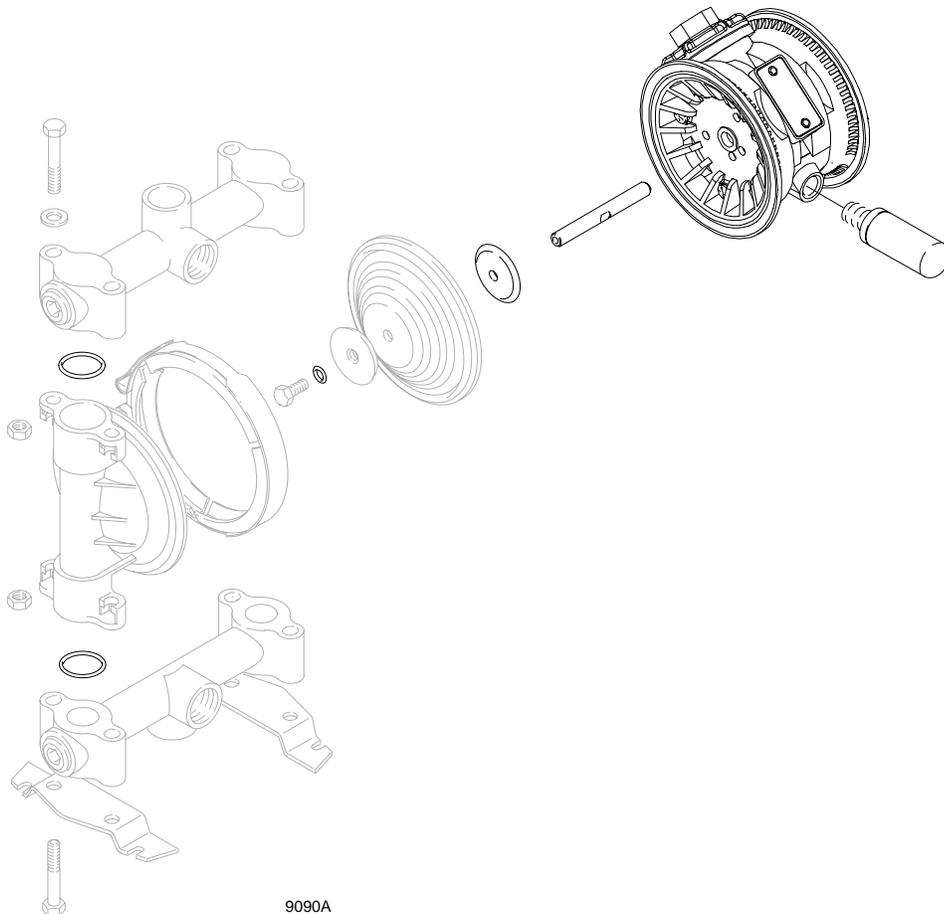

GRACO INC. P.O. BOX 1441 MINNEAPOLIS, MN 55440-1441

©COPYRIGHT 1999, GRACO INC.

Graco Inc. is registered to I.S. EN ISO 9001

Installation

Pressure Relief Procedure

WARNING

PRESSURIZED EQUIPMENT HAZARD

The equipment stays pressurized until pressure is manually relieved. To reduce the risk of serious injury from pressurized fluid, accidental spray, or splashing fluid, follow this procedure whenever you

- Are instructed to relieve pressure
- Stop pumping
- Check, clean, or service any system equipment
- Install or clean fluid nozzles

1. Shut off the air to the pump.
2. Open the dispensing valve, if used.
3. Open the fluid drain valve to relieve all fluid pressure, and have a container ready to catch the drainage.

Removing the Existing Air Motor

1.  Follow the **Pressure Relief Procedure** above.
2. Remove the outlet and inlet manifolds, grounding strip, and vee clamps. Remove the center housing (shown below) from your Husky 715 pump.

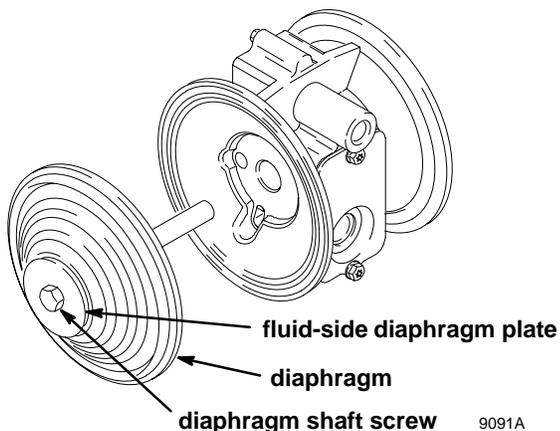

3. From the center housing that you took off of the pump, remove the diaphragm shaft screws, fluid-side diaphragm plates, and diaphragms. You will re-use these. Do not re-use the diaphragm shaft or the air-side diaphragm plates with the new air motor.

Installing the New Air Motor

1. Apply medium-strength (blue) Loctite® (9) or equivalent to threads of diaphragm shaft screw. Install on one end of the diaphragm shaft the following parts (see proper order in Parts Drawing): air-side diaphragm plate, diaphragm, fluid-side diaphragm plate, packing o-ring (7), and diaphragm shaft screw.
NOTE: The words "AIR SIDE" on the diaphragm and the flat side of the air-side diaphragm plate must face toward the diaphragm shaft.
2. Put grease (8) on the diaphragm shaft, and carefully (do not damage the shaft u-cups) run the diaphragm shaft through the center housing bore.
3. Repeat step 1 for the other end of the diaphragm shaft, and torque the diaphragm shaft screws to 80 to 90 in-lb (9 to 10 N-m) at 100 rpm maximum.
4. Install the muffler.

When installing vee clamps in step 6, orient center housing so air inlet is approximately 45° above horizontal and the muffler is approximately horizontal.

5. Apply thin, even film of grease on inside of vee clamp.
6. Position fluid covers, install vee clamps around fluid and air covers, install grounding strip on vee clamps, and torque vee clamp nuts from 80 to 90 in-lb (9 to 10 N-m).
7. Make sure all check valve parts are in place.
8. Install manifold o-rings (6) and manifolds, and torque manifold bolts from 80 to 90 in-lb (9 to 10 N-m).

Operating the Retrofitted Pump

See instruction manual 308981 for Operating and Service instructions and Parts information.

Parts

Husky 716 Air Motor Retrofit Kit

Part No. 241631, with standard air motor

Part No. 241664, with remote-operated air motor

Ref. No.	Part No.	Description	Qty
1	240224	MOTOR, air, standard Included in Kit 241631 <i>See manual 308981 for parts.</i>	1
1	241255	MOTOR, air, remote-operated Included in Kit 241664 <i>See manual 308981 for parts.</i>	1
2	194246	COVER, air	2
3	114882	SCREW, torx	12
4	290045	PLATE, designation	1
5	111183	RIVET, <i>for designation plate (4)</i>	2
6	110636	O-RING	8
7	110004	PACKING, o-ring	2
7	104893	PACKING, o-ring	2
8	111920	LUBRICANT, grease (not shown)	1
9	113500	ADHESIVE, anaerobic (not shown)	1
10	108808	PACKING, u-cup (not shown) <i>For diaphragm shaft</i>	2

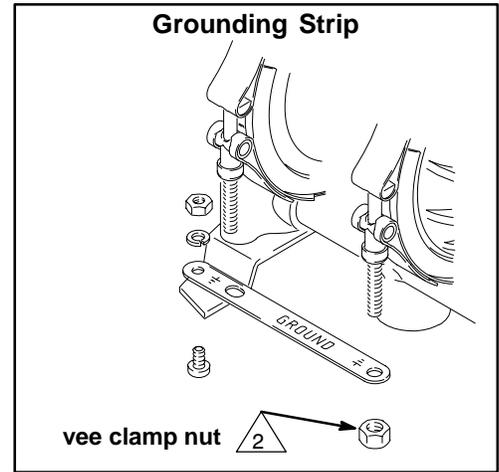

NOTE: Parts shown with solid lines in the drawing below are included in the Air Motor Retrofit Kit.

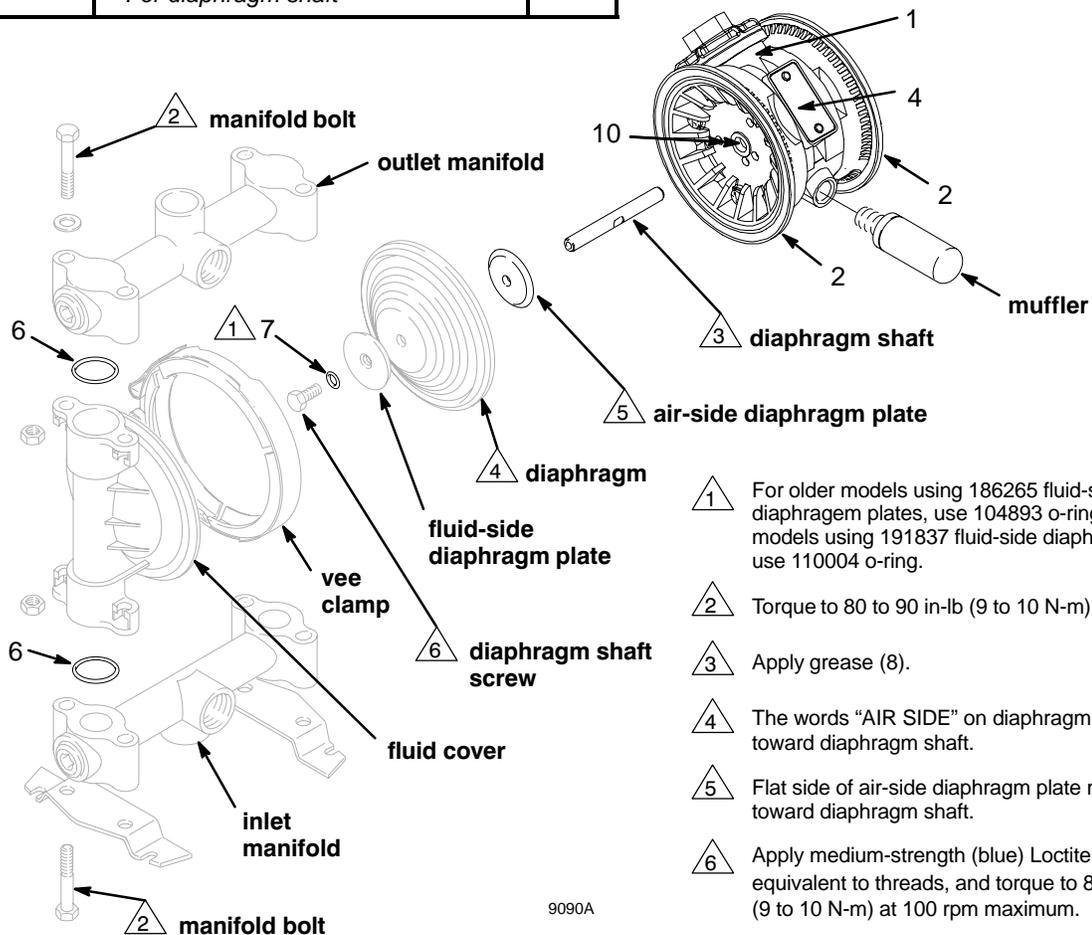

- 1 For older models using 186265 fluid-side diaphragm plates, use 104893 o-ring. For newer models using 191837 fluid-side diaphragm plates, use 110004 o-ring.
- 2 Torque to 80 to 90 in-lb (9 to 10 N-m).
- 3 Apply grease (8).
- 4 The words "AIR SIDE" on diaphragm must face toward diaphragm shaft.
- 5 Flat side of air-side diaphragm plate must face toward diaphragm shaft.
- 6 Apply medium-strength (blue) Loctite® (9) or equivalent to threads, and torque to 80 to 90 in-lb (9 to 10 N-m) at 100 rpm maximum.

9090A

Graco Standard Warranty

Graco warrants all equipment manufactured by Graco and bearing its name to be free from defects in material and workmanship on the date of sale by an authorized Graco distributor to the original purchaser for use. With the exception of any special, extended, or limited warranty published by Graco, Graco will, for a period of twelve months from the date of sale, repair or replace any part of the equipment determined by Graco to be defective. This warranty applies only when the equipment is installed, operated and maintained in accordance with Graco's written recommendations.

This warranty does not cover, and Graco shall not be liable for general wear and tear, or any malfunction, damage or wear caused by faulty installation, misapplication, abrasion, corrosion, inadequate or improper maintenance, negligence, accident, tampering, or substitution of non-Graco component parts. Nor shall Graco be liable for malfunction, damage or wear caused by the incompatibility of Graco equipment with structures, accessories, equipment or materials not supplied by Graco, or the improper design, manufacture, installation, operation or maintenance of structures, accessories, equipment or materials not supplied by Graco.

This warranty is conditioned upon the prepaid return of the equipment claimed to be defective to an authorized Graco distributor for verification of the claimed defect. If the claimed defect is verified, Graco will repair or replace free of charge any defective parts. The equipment will be returned to the original purchaser transportation prepaid. If inspection of the equipment does not disclose any defect in material or workmanship, repairs will be made at a reasonable charge, which charges may include the costs of parts, labor, and transportation.

THIS WARRANTY IS EXCLUSIVE, AND IS IN LIEU OF ANY OTHER WARRANTIES, EXPRESS OR IMPLIED, INCLUDING BUT NOT LIMITED TO WARRANTY OF MERCHANTABILITY OR WARRANTY OF FITNESS FOR A PARTICULAR PURPOSE.

Graco's sole obligation and buyer's sole remedy for any breach of warranty shall be as set forth above. The buyer agrees that no other remedy (including, but not limited to, incidental or consequential damages for lost profits, lost sales, injury to person or property, or any other incidental or consequential loss) shall be available. Any action for breach of warranty must be brought within two (2) years of the date of sale.

Graco makes no warranty, and disclaims all implied warranties of merchantability and fitness for a particular purpose in connection with accessories, equipment, materials or components sold but not manufactured by Graco. These items sold, but not manufactured by Graco (such as electric motors, switches, hose, etc.), are subject to the warranty, if any, of their manufacturer. Graco will provide purchaser with reasonable assistance in making any claim for breach of these warranties.

In no event will Graco be liable for indirect, incidental, special or consequential damages resulting from Graco supplying equipment hereunder, or the furnishing, performance, or use of any products or other goods sold hereto, whether due to a breach of contract, breach of warranty, the negligence of Graco, or otherwise.

FOR GRACO CANADA CUSTOMERS

The parties acknowledge that they have required that the present document, as well as all documents, notices and legal proceedings entered into, given or instituted pursuant hereto or relating directly or indirectly hereto, be drawn up in English. Les parties reconnaissent avoir convenu que la rédaction du présente document sera en Anglais, ainsi que tous documents, avis et procédures judiciaires exécutés, donnés ou intentés à la suite de ou en rapport, directement ou indirectement, avec les procédures concernées.

Graco Phone Number

TO PLACE AN ORDER, contact your Graco distributor, or call this number to identify the distributor closest to you:
1-800-367-4023 Toll Free

Loctite® is a registered trademark of the Loctite Corporation.

*All written and visual data contained in this document reflect the latest product information available at the time of publication.
Graco reserves the right to make changes at any time without notice.*

Sales Offices: Minneapolis, Detroit

Foreign Offices: Belgium, Korea, Hong Kong, Japan

GRACO INC. P.O. BOX 1441 MINNEAPOLIS, MN 55440-1441

www.graco.com

PRINTED IN USA 308983 May 1999. Revised February 2000

Free Manuals Download Website

<http://myh66.com>

<http://usermanuals.us>

<http://www.somanuals.com>

<http://www.4manuals.cc>

<http://www.manual-lib.com>

<http://www.404manual.com>

<http://www.luxmanual.com>

<http://aubethermostatmanual.com>

Golf course search by state

<http://golfingnear.com>

Email search by domain

<http://emailbydomain.com>

Auto manuals search

<http://auto.somanuals.com>

TV manuals search

<http://tv.somanuals.com>