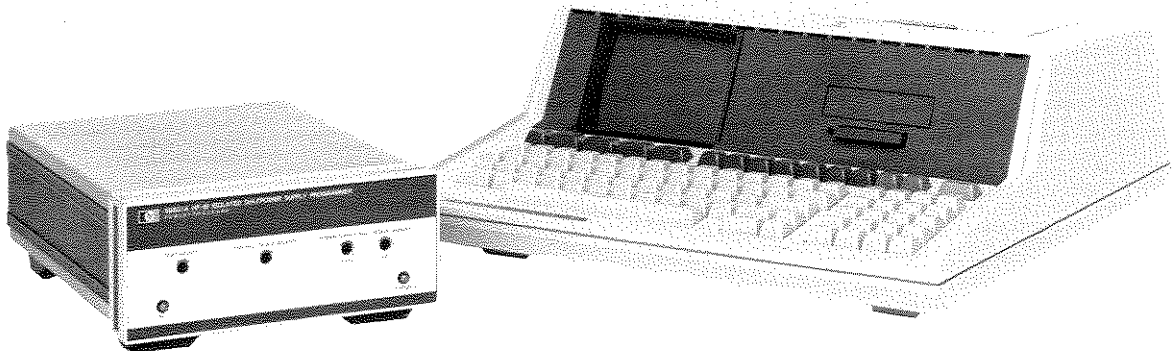


SUPERSEDES: NONE

## Introductory Operating Guide for the 59501A D/A-Power Supply Programmer with the HP 85 Computer



### Table of Contents

Section	Page
① Assembling the System.....	2
② Calibration.....	10
③ Programming .....	13

### Introduction

This note is a guide to the basic operation of the 59501A, as either a remote power supply programmer or a programmable low level DC voltage source, with the HP 85 computer.

Familiarity with the HP 85 and its programming language, BASIC, makes the examples more meaningful. The HP 85's capabilities are best described in the manuals listed in the section titled Related Documents. To acquaint yourself with the HP 85, review these manuals and use them as a reference as

you gain experience. When you are familiar with the HP 85, this note will enable you to quickly write programs that control the 59501A.

### Related Documents

In addition to the modes of operation described in this note, the 59501A, and HP 85 have other useful capabilities. The materials listed below contain complete documentation for all of these capabilities. They can be obtained through your nearest Hewlett-Packard sales office.

#### 59501A Literature

Operating and Service Manual (59501-90001)

#### HP 85 Literature

Owner's Manual and Programming Guide (00085-90002)

Quick Reference Guide (00085-90040)

I/O Programming Guide (00085-90142)

#### HP-IB Literature

Tutorial Description of the Hewlett-Packard Interface Bus (5952-0156)

# ① Assembling the System

## A. Required Equipment

The programs contained in this note require the following equipment:

1. 59501A HP-IB Isolated D/A Power Supply Programmer
2. HP 85 Computer
  - a. ROM drawer (82936A)
  - b. I/O programming ROM (00085-15003)
  - c. HP-IB Interface (82937A)
3. For use as a power supply programmer:  
The Hewlett-Packard power supply you wish to program (see Table 1).

NOTE: A digital voltmeter (DVM) is necessary for proper calibration. The HP 3465B or equivalent is recommended.

## B. Set-Up

With all ac power turned off:

1. Make sure that the I/O programming ROM and ROM drawer are in place in the HP 85.
2. Verify that the address switches on the back panel of the 59501A are set to 06. (See Figure 1).
3. Insert the HP-IB interface into one of the HP 85's rear panel slots.
4. Attach the connector at the free end of the interface cable to the rear of the 59501A.

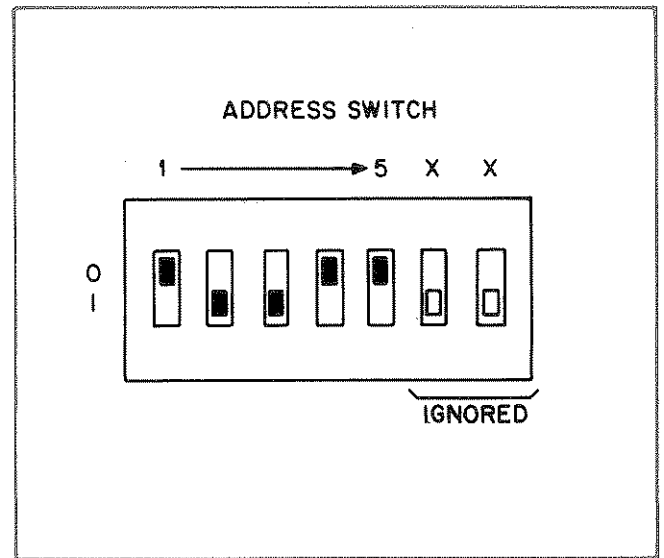


Figure 1.

Table 1 59501A Power Supply Connection Guide

HP Model #	Constant Voltage Operation	Constant Current Operation	HP Model #	Constant Voltage Operation	Constant Current Operation	HP Model #	Constant Voltage Operation	Constant Current Operation
6002A	Fig. # 3	Fig. # 22	6259B	Fig. # 13	Fig. # 29	6434B	Fig. # 17	Fig. # *
6012A	4	23	6260B	13	29	6438B	17	*
6024A	5	24	6261B	13	29	6439B	17	*
6111A	6	*	6263B	15	30	6443B	17	*
6112A	6	*	6264B	14	31	6448B	17	*
6113A	6	*	6266B	15	30	6453A	18	33
6114A	7	25	6267B	14	31	6456B	18	33
6115A	7	25	6268B	13	29	6459A	18	33
6116A	6	*	6269B	13	29	6464C	19	34
6177C	*	26	6271B	15	30	6466C	17	34
6181C	*	26	6274B	14	31	6469C	17	34
6186C	*	26	6281A	8	27	6472C	17	34
6200B	8	27	6282A	16	32	6475C	17	34
6203B	8	27	6284A	8	27	6477C	17	34
6205C	9	*	6286A	16	32	6479C	17	34
6206B	10	*	6289A	8	27	6483C	17	34
6207B	8	27	6291A	16	32	6824A	20	*
6209B	11	27	6294A	8	27	6825A	21	35
6227B	12	28	6296A	16	32	6826A	21	35
6228B	12	28	6299A	8	27	6827A	21	35
6253A	8	27	6428B	17	*			
6255A	8	27	6433B	17	*			

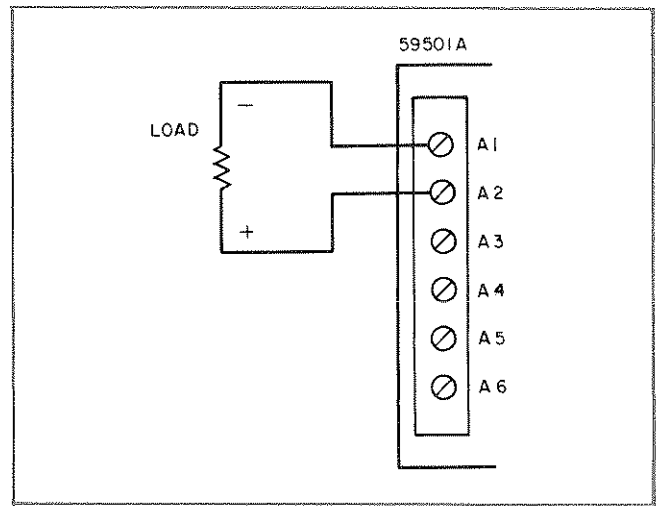
\*This mode is not available

**5. For operation as a power supply programmer:**

- Find the correct wiring diagram below, corresponding to power supply model number, and either CV or CC mode of operation. (See Table 1).
- Arrange the barrier strip jumpers on the power supply as illustrated in the diagram.
- Remove internal jumpers or components from the power supply if diagram requests.
- Wire the 59501A to the power supply as illustrated.
- Set range switch on power supply if applicable.
- Before permanently wiring the power supply to the 59501A, check the power supply operating and service manual for proper wiring technique and external components which may be needed to insure ripple and noise specifications.

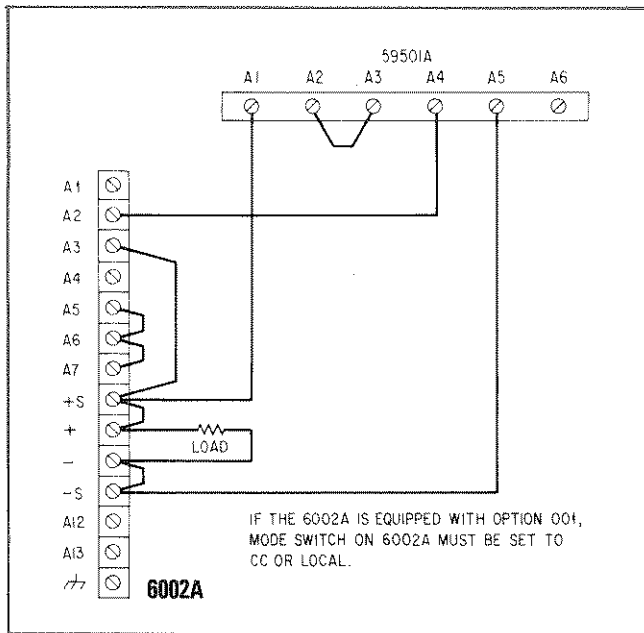
**6. For operation as a DC source:**

- Wire load to 59501A as illustrated in Figure 2.

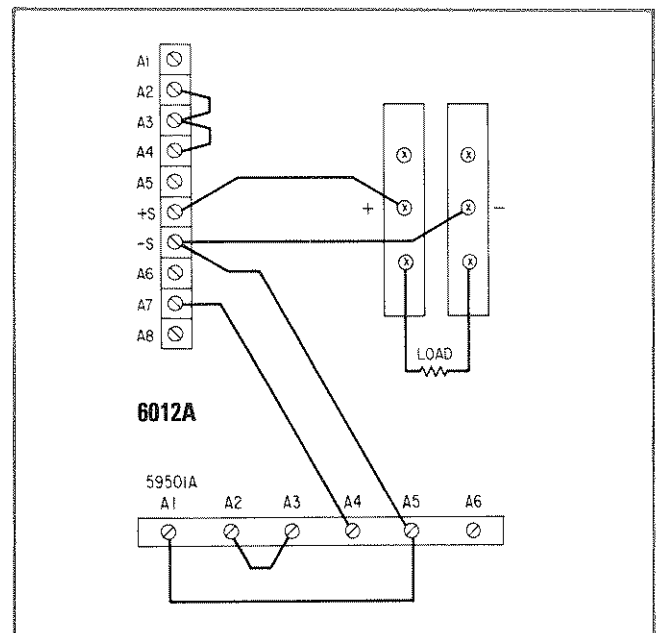


**Figure 2.** Connecting the 59501A as a Low Level Voltage Source.

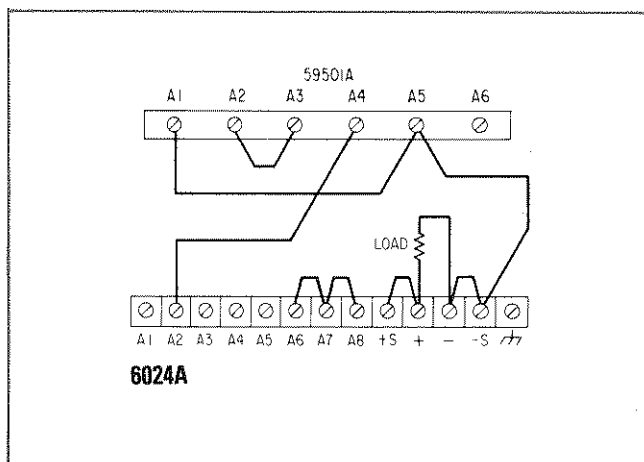
**CV Programming Connections**



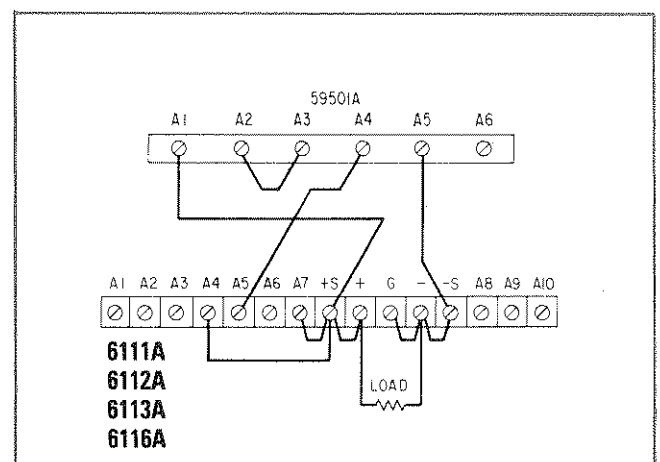
**Figure 3.**



**Figure 4.**



**Figure 5.**



**Figure 6.**

# CV Programming Connections (Cont.)

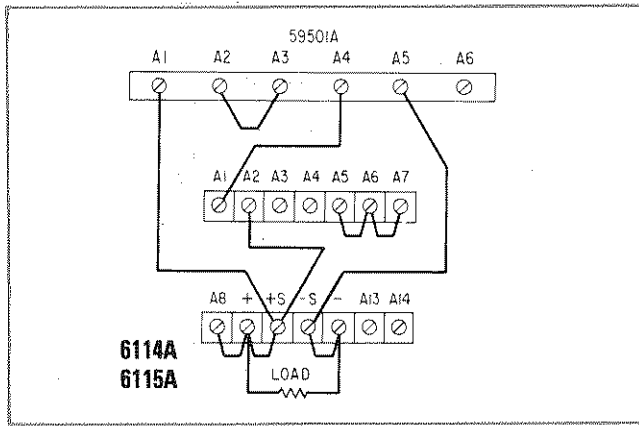


Figure 7.

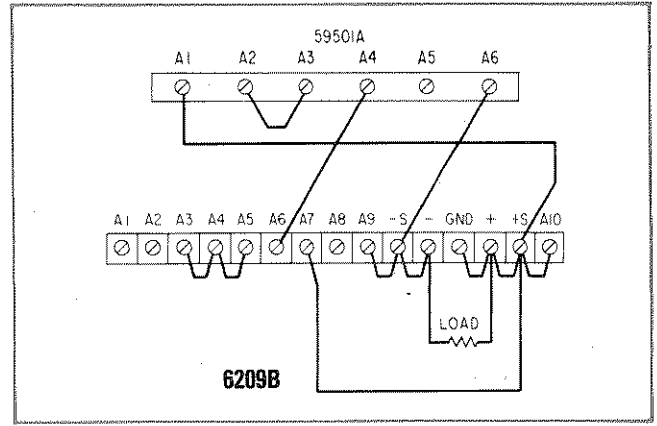


Figure 11.

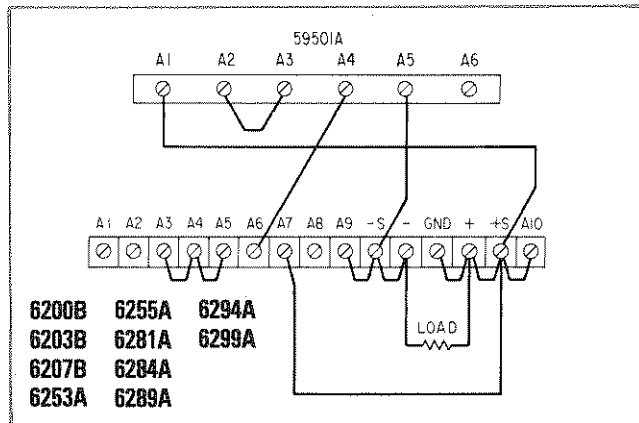


Figure 8.

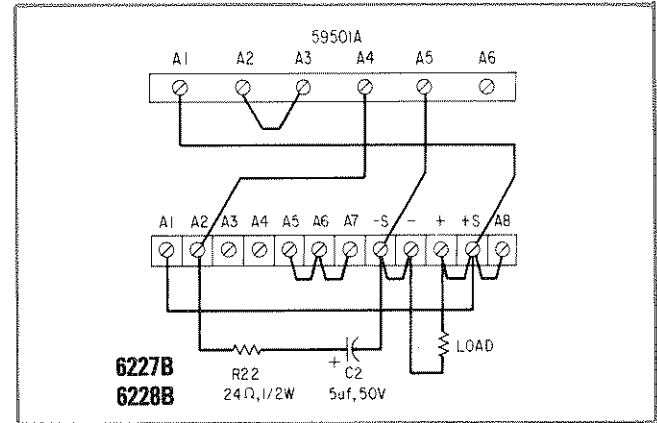


Figure 12.

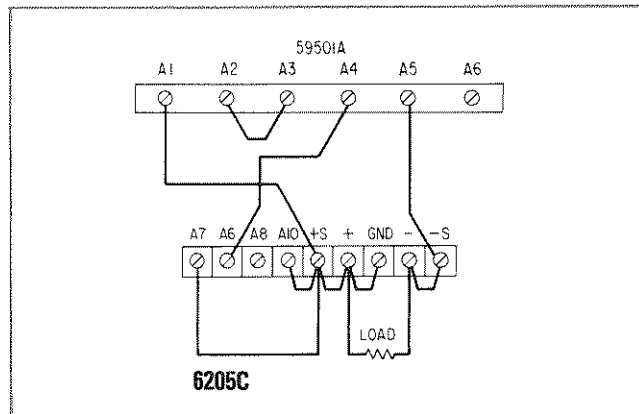


Figure 9.

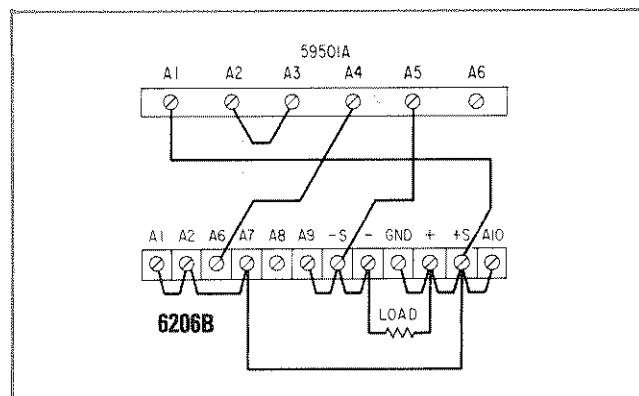


Figure 10.

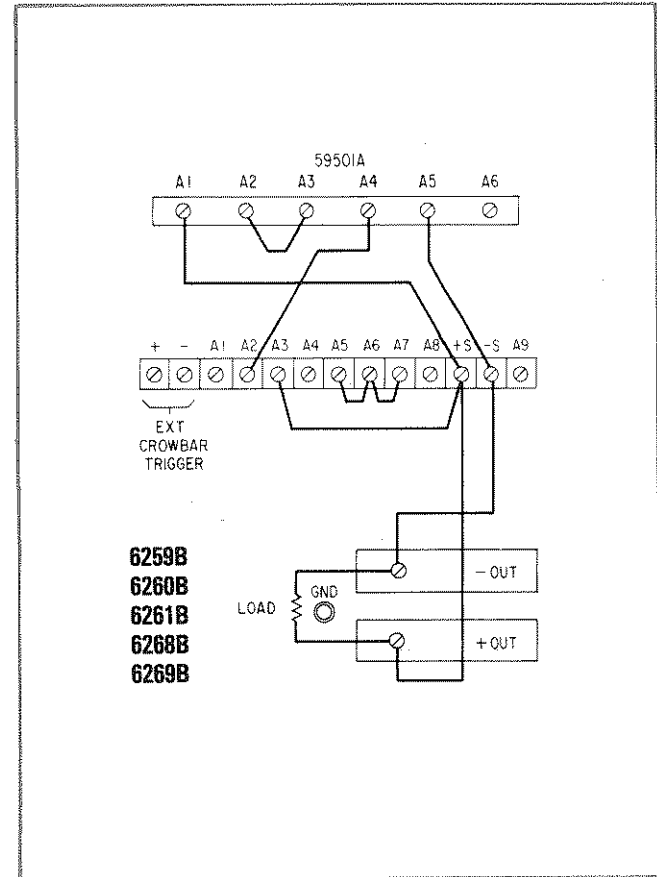


Figure 13.

# CV Programming Connections (Cont.)

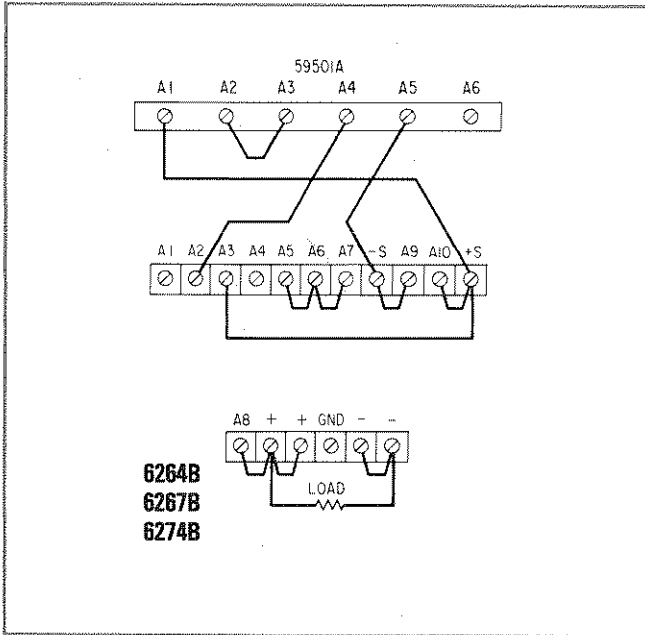


Figure 14.

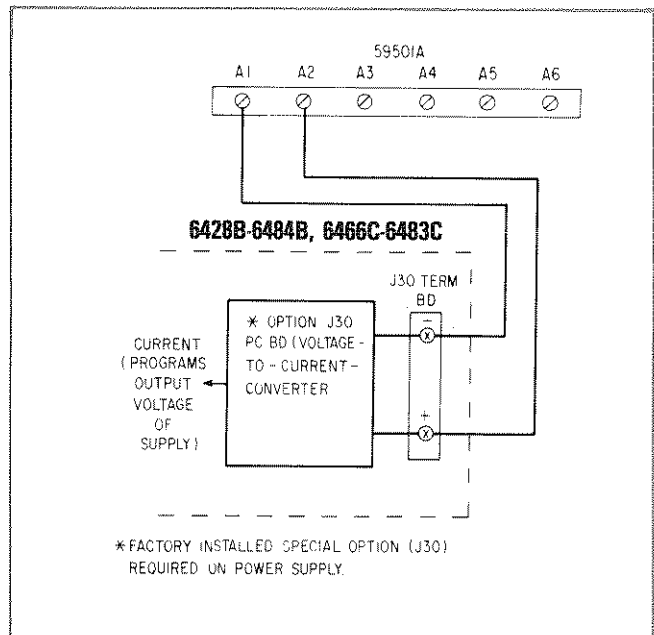


Figure 17.

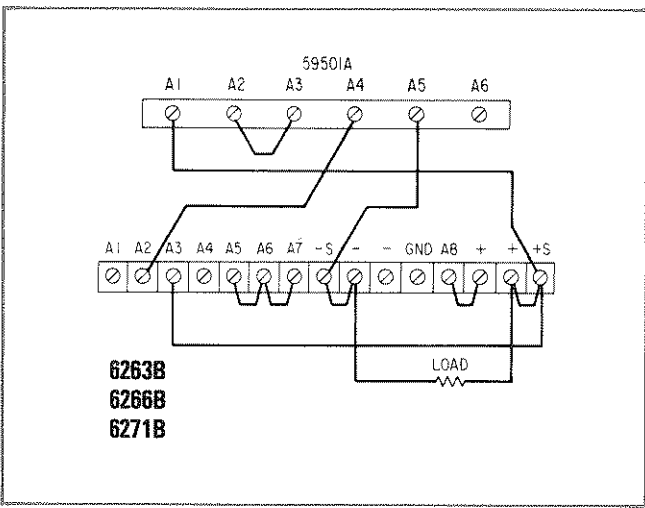


Figure 15.

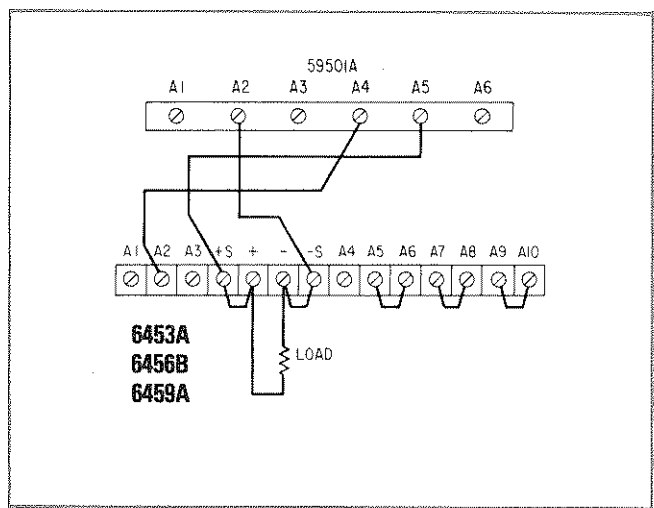


Figure 18.

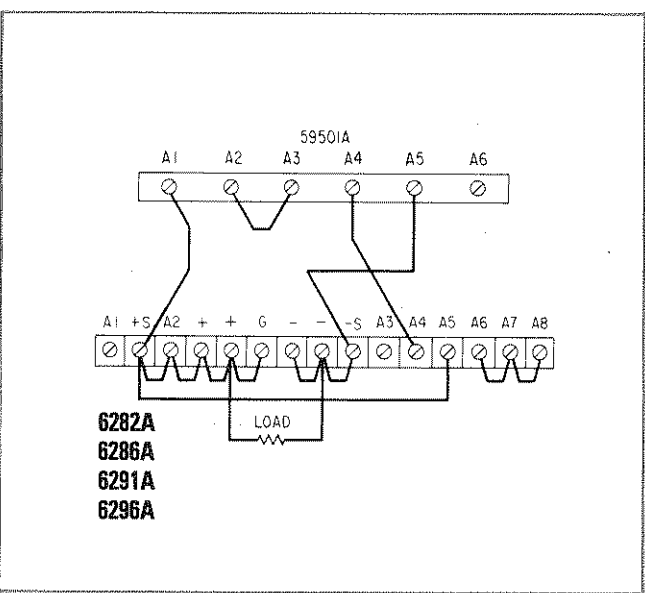


Figure 16.

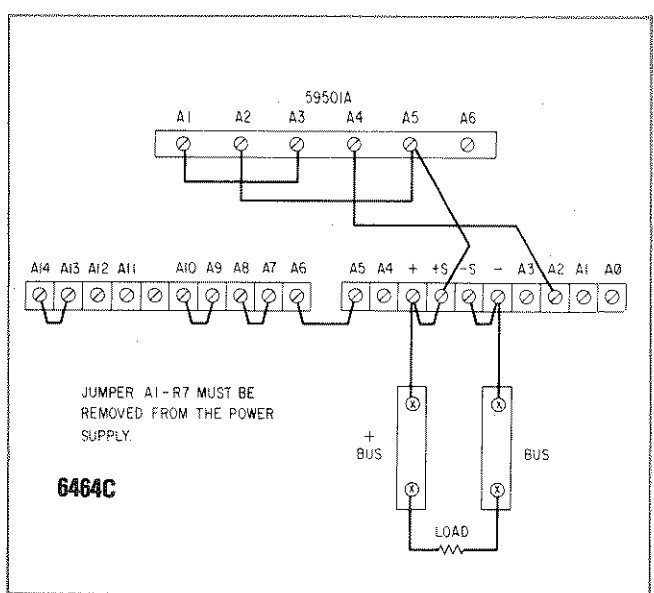


Figure 19.

## CV Programming Connections (Cont.)

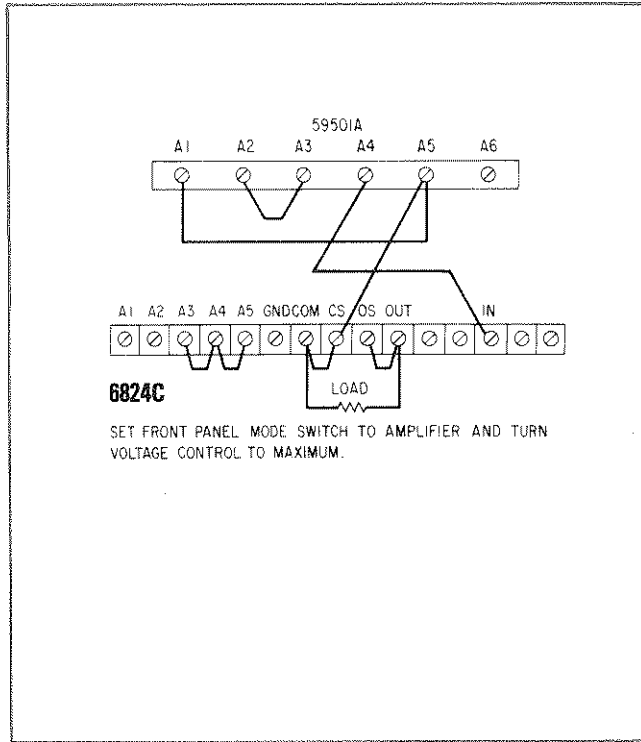


Figure 20.

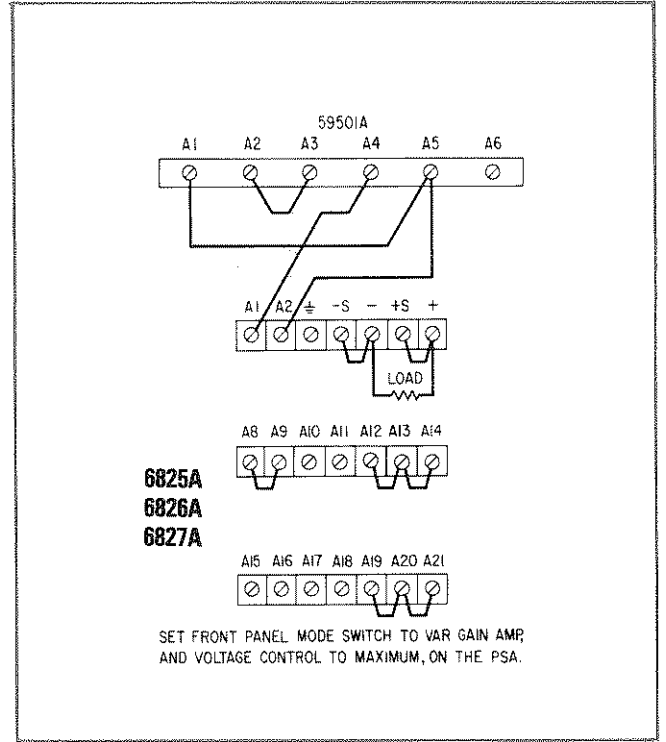


Figure 21.

## CC Programming Connections

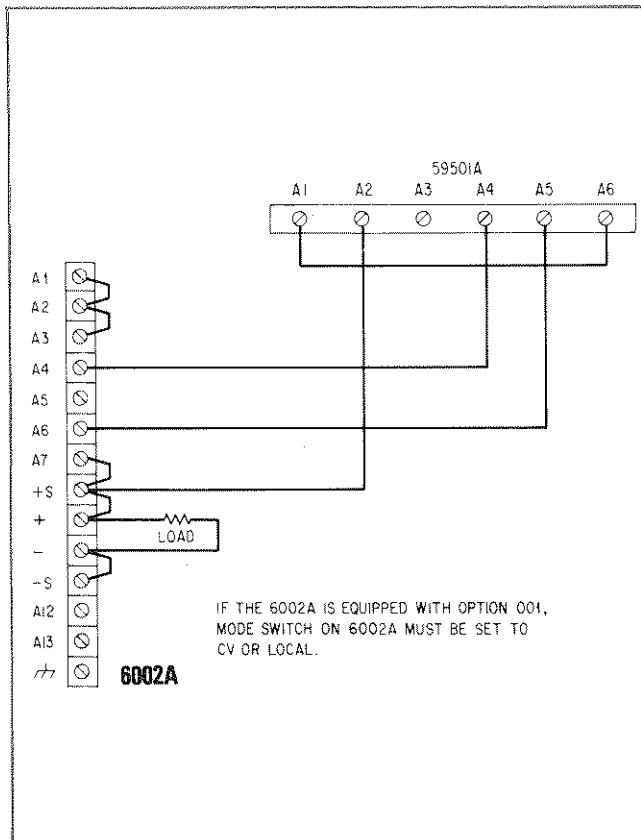


Figure 22.

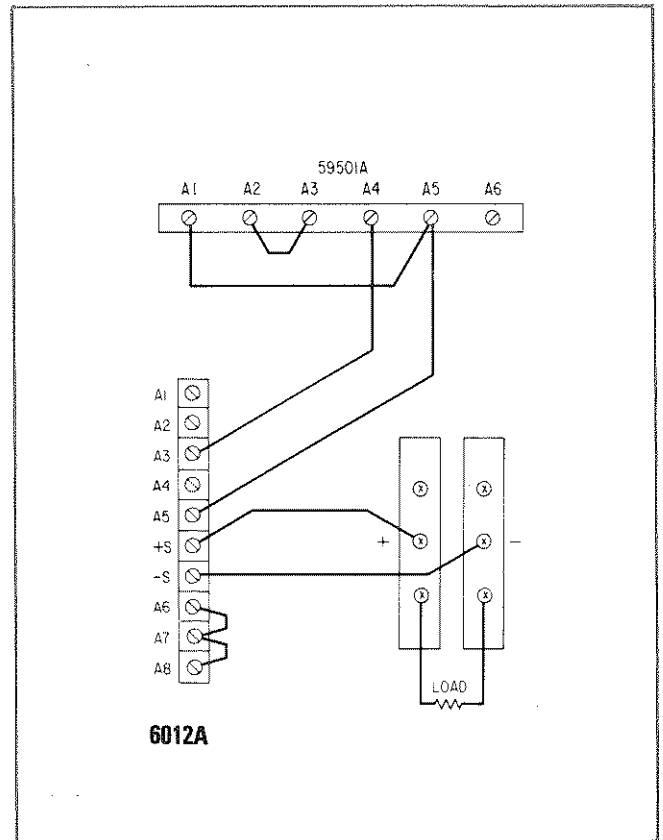


Figure 23.

# CC Programming Connections (Cont.)

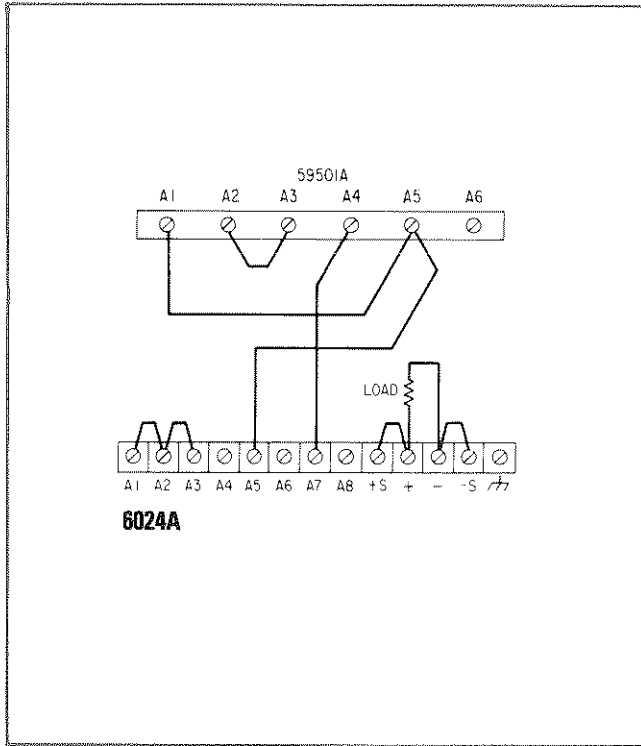


Figure 24.

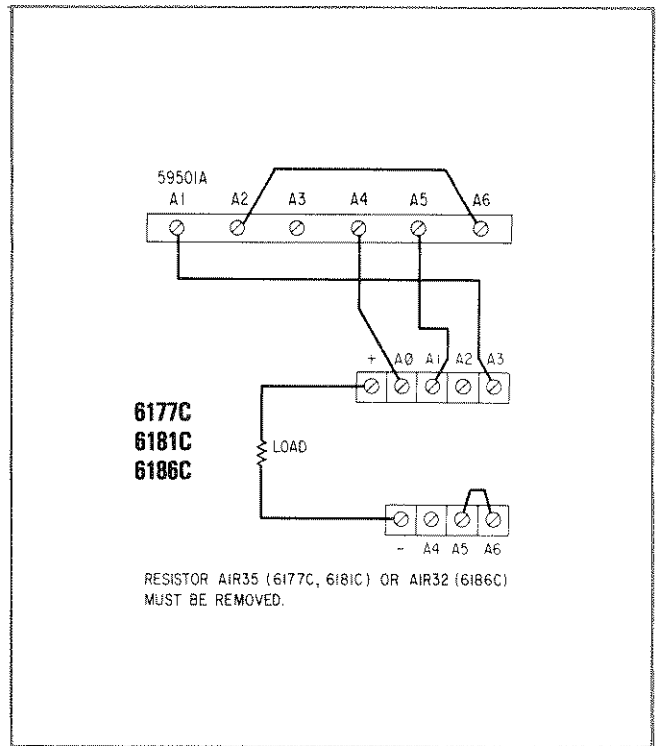


Figure 26.

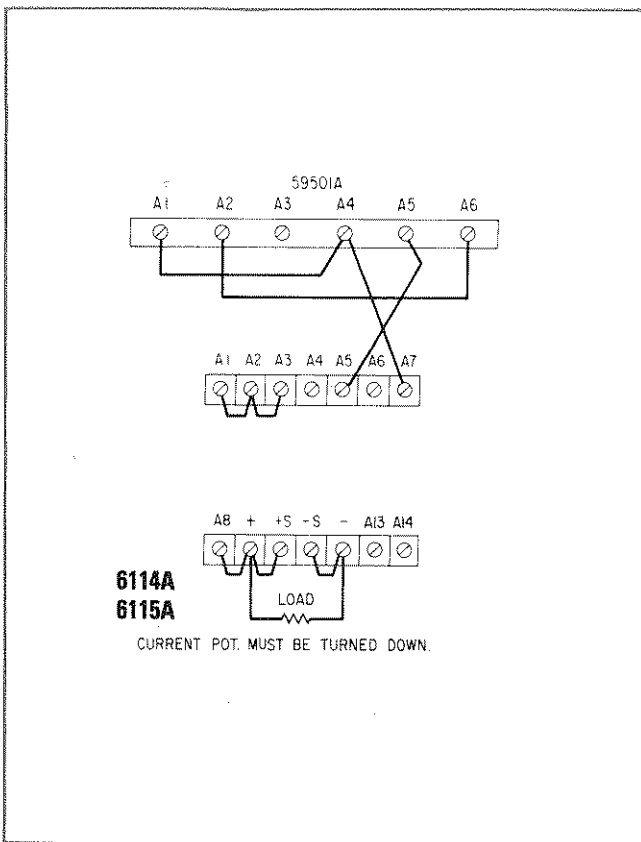


Figure 25.

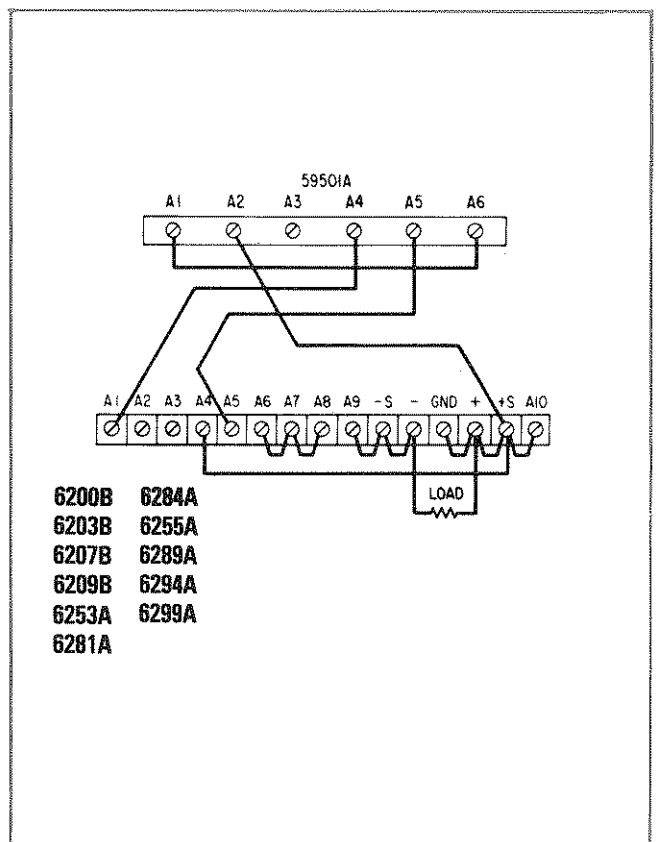


Figure 27.

# CC Programming Connections (Cont.)

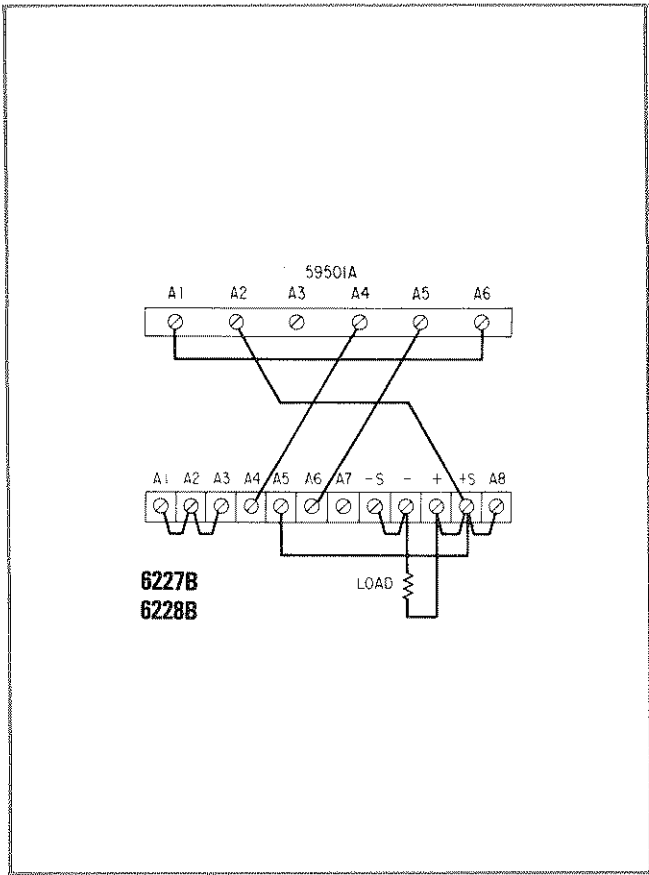


Figure 28.

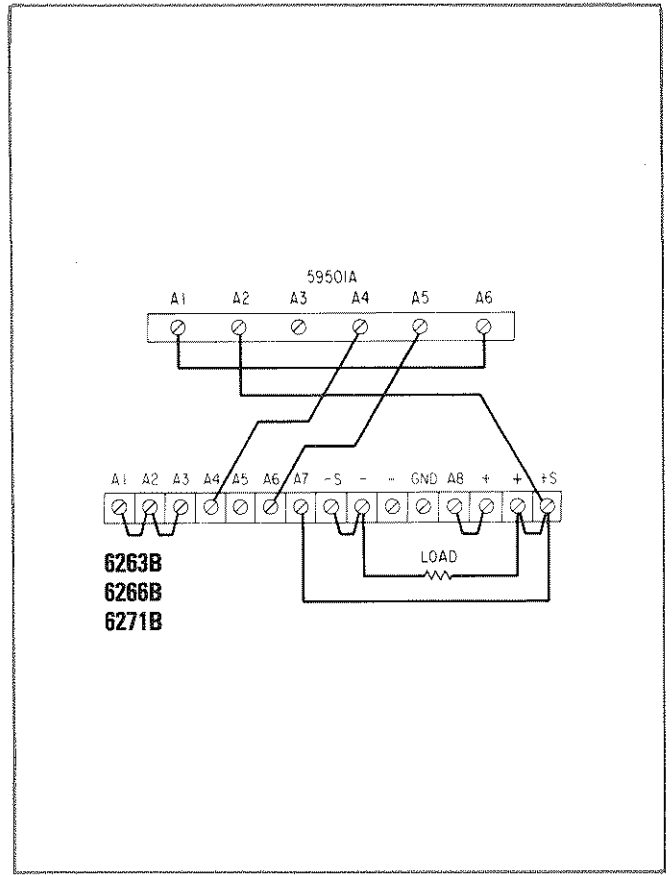


Figure 30.

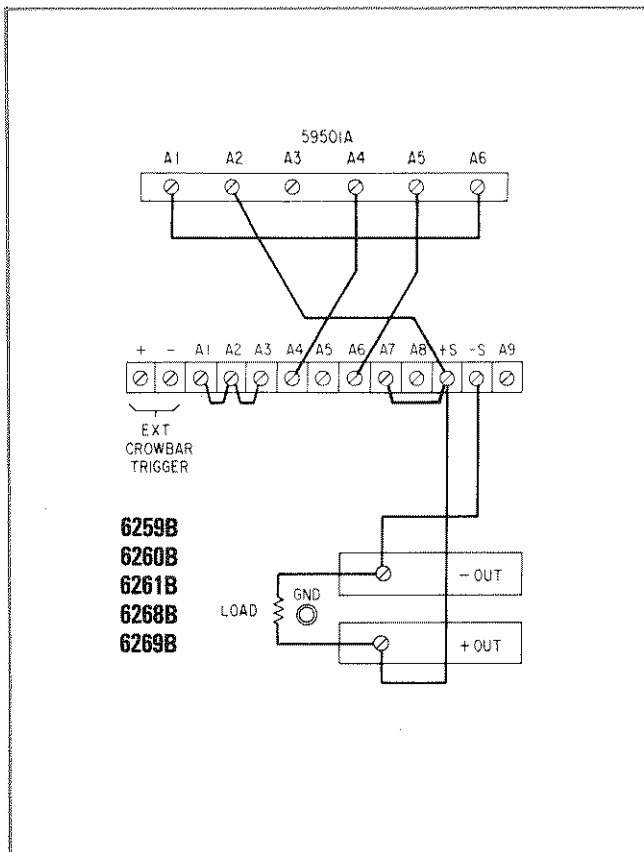


Figure 29.

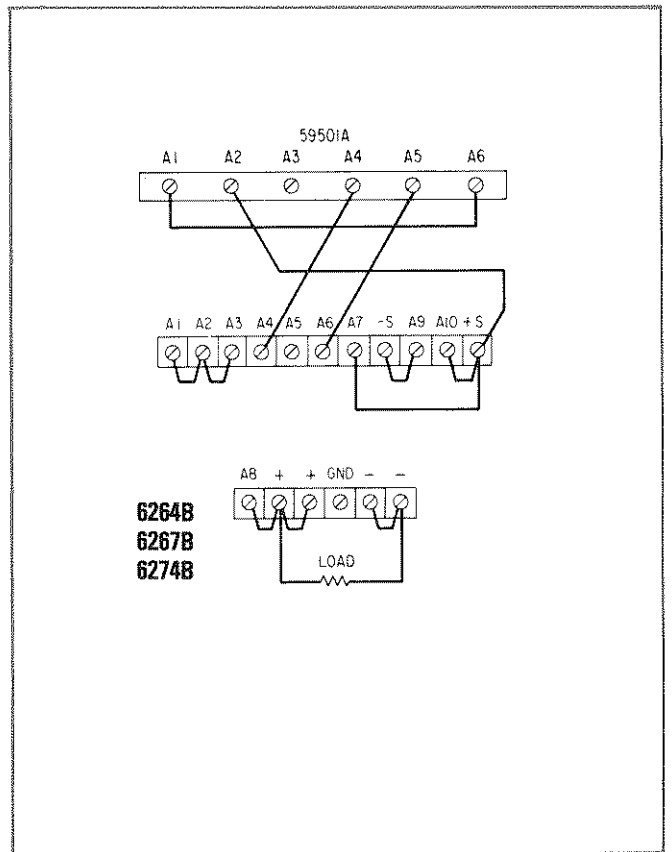


Figure 31.



# CC Programming Connections (Cont.)

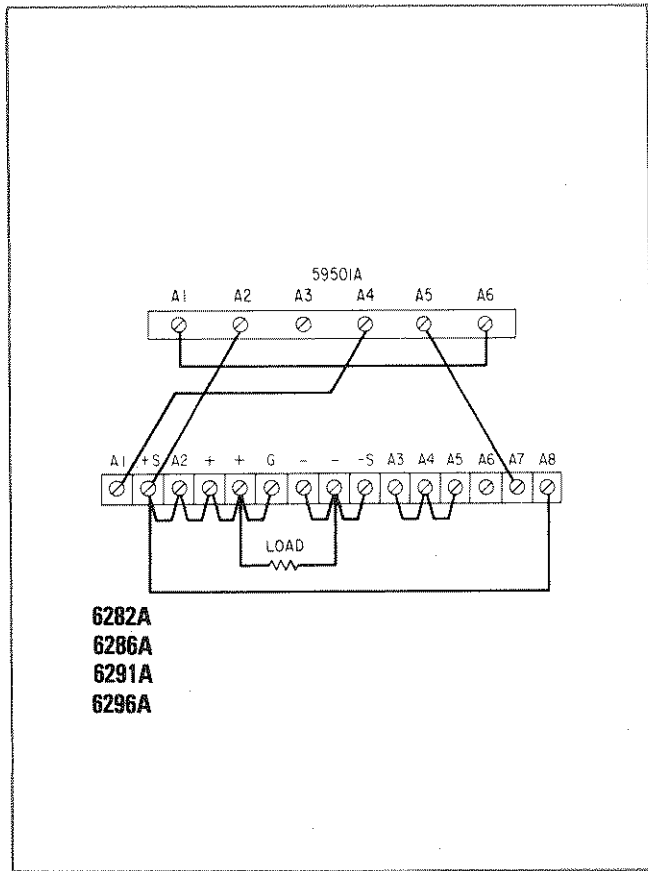


Figure 32.

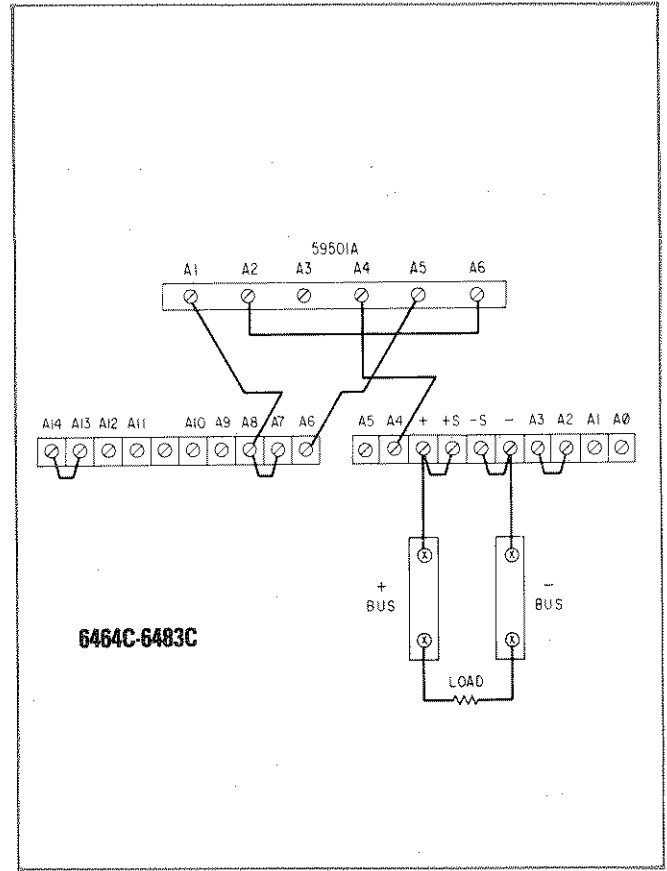


Figure 34.

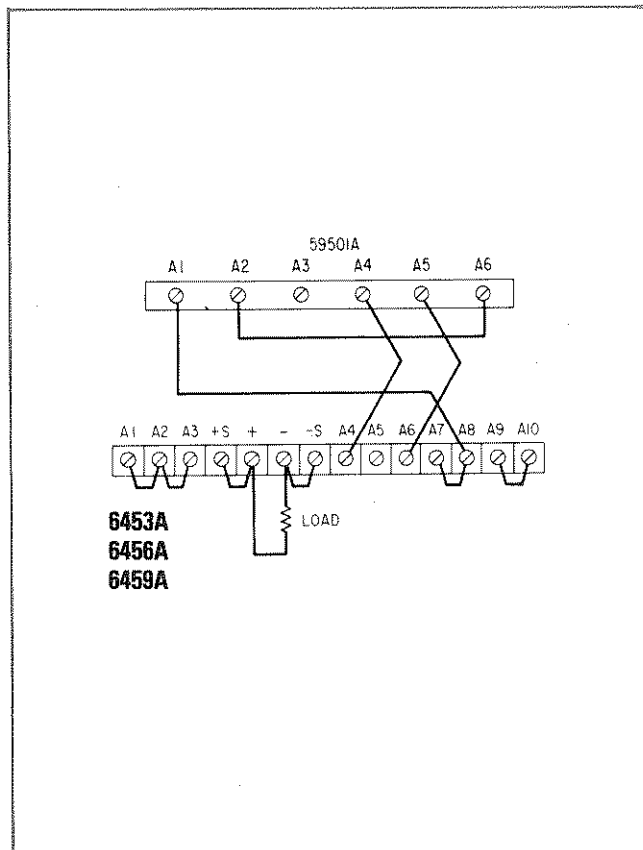


Figure 33.

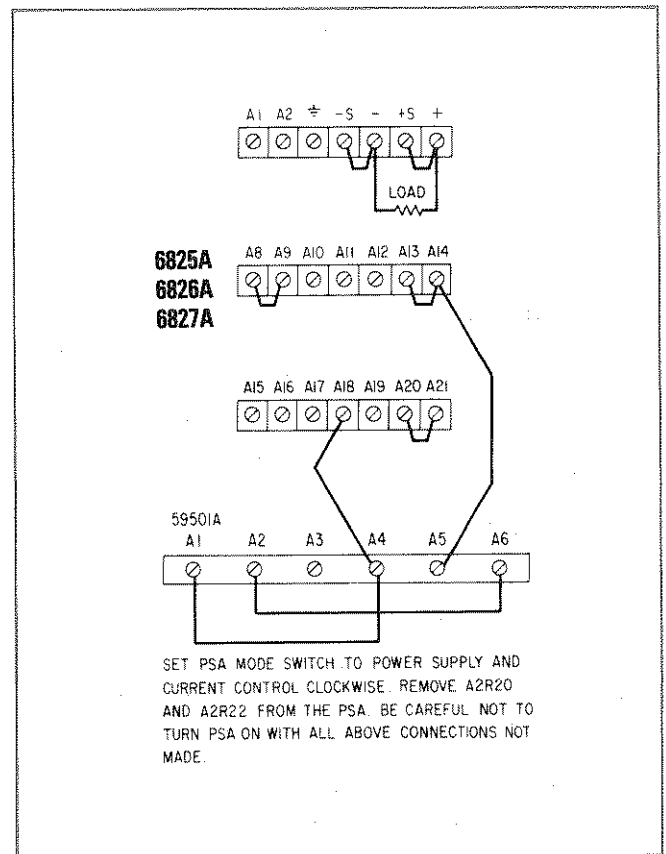


Figure 35.

## ② Calibration

### A. 59501A Programmer-Power Supply Combination

Before programming a 59501A-power supply combination, a two-step calibration procedure must be performed to match the particular power supply to the 59501A. A similar calibration is necessary when the 59501A is used as a low level DC signal source.

#### A-1. Unipolar Operation

##### Unipolar Constant Voltage Programming Calibration



1. Connect the digital voltmeter between the +S and -S terminals on the power supply.
2. Set the mode switch on the rear of the 59501A to UNIPOLAR and turn the POWER SUPPLY FULL SCALE ADJUST potentiometers fully counterclockwise.
3. If the power supply has a front panel current control, set it to mid-range.
4. Apply power to the HP 85, the 59501A, and the power supply. Allow a 30 minute warm-up.

##### Unipolar Constant Current Programming Calibration

1. Connect a resistive load in series with an external current monitoring resistor across the supply's output terminals. Refer to Section V of the applicable operating and service manual for resistor values, power ratings, and CC test setup diagram.
2. Connect a digital voltmeter across the current monitoring resistor.
3. Set the mode switch on the rear of the 59501A to UNIPOLAR and turn the POWER SUPPLY FULL SCALE ADJUST potentiometers fully counterclockwise.
4. On the power supply, set the front panel VOLTAGE control fully clockwise.
5. Apply power to the HP 85, 59501A and the power supply. Allow a 30 minute warm-up.

Figure 36 is a program for constant voltage programming calibration of a 59501A-power supply combination. It contains set-up and calibration routines, automatic range changing, and will prompt with an error message if the voltage entered is negative.

#### Instructions:

Enter the program and press . All required calibration operations are displayed on the CRT of the HP 85. The maximum desired output voltage (e.g. 20) should be entered when prompted by the program. The program automatically uses 99.9% of the value (e.g. 19.98) to calibrate the 59501A-power supply combination. To run the program again, press  then



```
10 !
20 !           CALIBRATION FOR
30 ! UNIPOLAR POWER SUPPLY
40 !           VOLTAGE OUTPUT
50 !
60 ! Set-up instructions
70 !
80 CLEAR
90 DISP "Set the 59501A mode switch to "
100 DISP "UNIPOLAR, then press CONT."
110 PAUSE
120 DISP "Turn the Power Supply Full Scale Adj
ustment pots fully CCW and then press CONT."
" @ DISP
130 PAUSE
140 !
150 ! User enters maximum output voltage des
ired.
160 !
170 DISP @ DISP "Enter the maximum output vol
tage"
180 INPUT V
190 IF V<=0 THEN BEEP @ DISP "NO NEGATIVE VOL
TAGES ALLOWED" @ GOTO 170
200 !
210 ! Resolution is calculated
220 ! and the maximum desired
230 ! output is changed to
240 ! 99.9% of the voltage
250 ! entered on line 170
260 !
270 D=V/1000
280 V=V-D
290 !
300 ! Calibration routine
310 !
320 OUTPUT 706 USING "#,4D" ; 2999
330 DISP "Set the Power Supply Full Scale Adj
ustment pots for an output of";V;"Volts."
340 DISP "Then press CONT."
350 PAUSE
360 CLEAR
370 OUTPUT 706 USING "#,4D" ; 2000
380 DISP "Set the Zero Adjust pot for an out
put of 0.000 Volts."
390 DISP "Then press CONT." @ DISP
400 PAUSE
410 OUTPUT 706 USING "#,4D" ; 2999
420 DISP "Adjust the Power Supply Full Sca
le Fine Adjust pot for an output of";V;"Vo
lts."
430 DISP "Then press CONT."
440 PAUSE
450 DISP " "
460 DISP "CALIBRATION COMPLETE"
470 END
```

Figure 36. Unipolar Power Supply Programmer Calibration Program.

The program listed in Figure 36 may be modified for constant current programming calibration of a 59501A power supply combination. Current must be substituted for voltage and the output current must be monitored using the above set-up.

## A-2 Bipolar Power Supply/Amplifier (BPS/A) Constant Voltage Calibration

1. Connect the DVM between the +S and -S terminals (Models 6825A-6827A) or between OS and CS terminals (Model 6824A), with the DVM common to -S or the OS terminal.
2. Set the mode switch on the rear of the 59501A to BIPOLAR.
3. On BPS/A, set mode switch to VAR GAIN AMP (6824A-6827A) or AMPLIFIER (6824A).
4. Turn the VOLTAGE controls on BPS/A fully counterclockwise.
5. On Models 6825A-6827A only, set the RANGE switch to the desired output range and set the CURRENT control to mid-range.

Figure 37 is a program for BPS/A constant voltage programming calibration. It contains set-up and

calibration routines, automatic range changing, and will prompt with an error message if the voltage entered is out of range.

### Instructions:

Enter the program and press **RUN**. All required calibration operations are displayed on the CRT of the HP 85. The maximum desired voltage (e.g. 20) should be entered when prompted by the program. The program automatically uses 99.9% of the value (e.g. 19.98) to calibrate the 59501A-BPS/A combination. To run the program again, press **RESET** then **RUN**.

The program listed in Figure 37 may be modified for constant current programming calibration of a 59501A-power supply combination. Reference instructions for unipolar constant current operation.

```
10 ! CALIBRATION FOR
20 ! BIPOLAR POWER SUPPLY
30 ! 59501A VOLTAGE OUTPUT
40 !
50 ! Set-up instructions
60 !
70 CLEAR
80 DISP "Set the 59501A mode switch to"
90 DISP "BIPOLAR, then press CONT."
100 PAUSE
110 DISP "Turn the POWER SUPPLY FULL"
120 DISP "SCALE ADJUST pots fully"
130 DISP "counterclockwise, then"
140 DISP "press CONT."
150 PAUSE
160 !
170 DISP " "
180 DISP "Enter the power supply full"
190 DISP "scale output voltage."
200 INPUT F
210 F=ABS(F)
220 F2=.999*F
230 !
240 ! Calibration routine
250 !
260 OUTPUT 706 USING "#,4D" ; 2999
270 DISP "Set the POWER SUPPLY FULL SCALE"
280 DISP "ADJUST and the D/A FULL SCALE"
290 DISP "ADJUST for an output of"
300 DISP F2;"volts."
310 DISP "Then press CONT."
320 PAUSE
330 OUTPUT 706 USING "#,4D" ; 2000
340 DISP " "
350 DISP " "
360 DISP "Enter DVM reading"
370 INPUT V
380 V=ABS(V)
390 DISP " "
400 Y=(F+V)/2
410 Y=-Y
420 DISP "Set the ZERO ADJUST for an"
430 DISP "output of";Y;"Volts."
440 DISP "Then press CONT."
450 PAUSE
460 OUTPUT 706 USING "#,4D" ; 2999
470 DISP " "
480 DISP "Re-adjust the D/A FULL SCALE"
490 DISP "ADJUST for an output of";F2
500 DISP "Volts. Then press CONT."
510 PAUSE
520 DISP " "
530 DISP "CALIBRATION COMPLETE."
540 END
```

Figure 37. Bipolar Power Supply Programmer Calibration Program.

## B. 59501A as a Low Level DC Signal Source

### B-1. Unipolar Mode Calibration

1. Connect the DVM between the A1 and A2 output terminals of the 59501A. Connect the DVM common to the A1 terminal.
2. Set the mode switch on the rear of the 59501A to UNIPOLAR.
3. Apply power to the HP 85 and the 59501A. Allow a 30 minute warm-up.

Figure 38 is a program for calibrating the 59501A for use as a low level unipolar DC signal source. It includes set-up and calibration routines.

#### Instructions:

Enter the program and press **RUN**. All calibration operations are displayed on the CRT of the HP 85. To run the program again, press **RESET** then **RUN**.

```
10 ! CALIBRATION FOR
20 ! UNIPOLAR 59501A VOLTAGE
30 ! OUTPUT
40 !
50 ! Set-up instructions
60 !
70 CLEAR
80 DISP "Set the 59501A mode switch to"
90 DISP "UNIPOLAR, then press CONT."
100 PAUSE
110 !
120 ! Calibration routine
130 !
140 OUTPUT 706 USING "#,4D" ; 2000
150 DISP "Set the ZERO ADJUST for an"
160 DISP "output of 0.000 Volts."
170 DISP "Then press CONT."
180 PAUSE
190 OUTPUT 706 USING "#,4D" ; 2999
200 DISP " "
210 DISP "Set the D/A FULL SCALE ADJUST"
220 DISP "for an output of 9.99 Volts."
230 DISP "Then press CONT."
240 PAUSE
250 DISP " "
260 DISP "CALIBRATION COMPLETE"
270 END
```

Figure 38. Unipolar D/A Calibration Program.

### B-2. Bipolar Mode Calibration

1. Connect the DVM between the A1 and A2 output terminals of the 59501A. Connect the DVM common to the A1 terminal.
2. Set the mode switch on the rear of the 59501A to BIPOLAR.
3. Apply power to the HP 85 and the 59501A.

Figure 39 is a program for calibrating the 59501A for use as a low level bipolar DC signal source. It includes set-up and calibration routines.

#### Instructions:

Enter the program and press **RUN**. All calibration operations are displayed on the CRT of the HP 85. To run the program again, press **RESET** then **RUN**.

```
5 ! CALIBRATION FOR
10 ! BIPOLAR 59501A VOLTAGE
20 ! OUTPUT
30 !
40 ! Set-up instructions
50 !
60 CLEAR
70 DISP "Set the 59501A mode switch to"
80 DISP "BIPOLAR, then press CONT."
90 PAUSE
100 !
110 ! Calibration routine
120 !
130 OUTPUT 706 USING "#,4D" ; 2999
140 DISP "Set the D/A FULL SCALE ADJUST"
150 DISP "for an output of 9.980 Volts."
160 DISP "Then press CONT."
170 PAUSE
180 OUTPUT 706 USING "#,4D" ; 2000
190 DISP " "
200 DISP " "
210 DISP "Enter DVM reading"
220 INPUT V
230 V=ABS(V)
240 DISP " "
250 Y=(10+V)/2
260 Y=-Y
270 DISP "Set the ZERO ADJUST for an"
280 DISP "output of";Y;"Volts."
290 DISP "Then press CONT."
300 PAUSE
310 OUTPUT 706 USING "#,4D" ; 2999
320 DISP " "
330 DISP "Re-adjust the D/A FULL SCALE"
340 DISP "ADJUST for an output of 9.980"
350 DISP "Volts. Then press CONT."
360 PAUSE
370 DISP " "
380 DISP "CALIBRATION COMPLETE."
390 END
```

Figure 39. Bipolar D/A Calibration Program.

# ③ Programming

The 59501A is an HP-IB instrument capable of performing a LISTEN function on the interface bus. It is programmed by a data word comprised of four digits. The first digit selects the range and the following three digits specify the desired output within the range, in terms of percentage of full scale. The 59501A output is either unipolar or bipolar, depending on the position of the mode switch on the back panel. Table 2 shows a few examples of programmed data words.

<b>D1</b>	<b>D2 D3 D4</b>
Range	Magnitude
1 = Low Range	000-999
2 = High Range	

Table 2  
Example Data Words

% of Power Supply Full Scale Output	59501A Output	Programmed Data Word
<b>UNIPOLAR</b>		
99.9%	9.99 V	2999
50.0%	5.00 V	2500
9.99%	0.999 V	1999
5.00%	0.500 V	1500
0%	0 V	1000, 2000
<b>BIPOLAR</b>		
<b>Positive Output</b>		
99.8%	9.98 V	2999
50.0%	5.00 V	2750
9.98%	0.998 V	1999
0%	0 V	2500, 1500
<b>Negative Output</b>		
100%	-10 V	2000
10%	-1 V	1000

## A. Range Selection

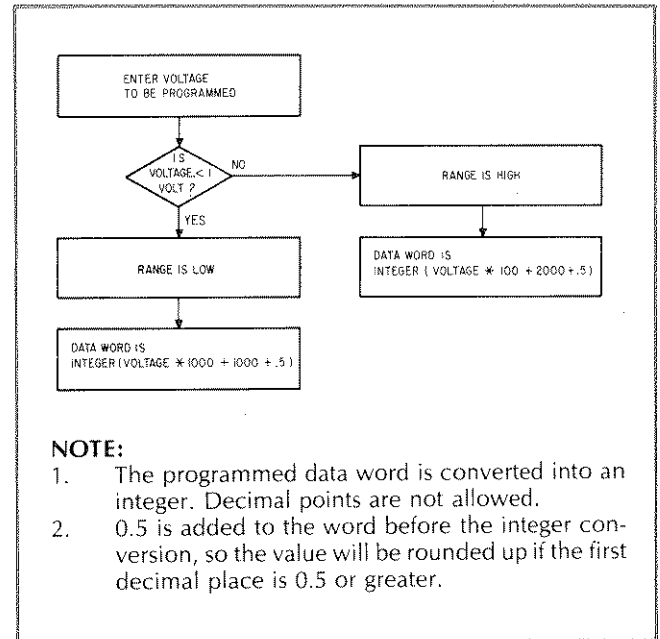
Before choosing the three magnitude digits, the range digit must be selected.

The low range covers 0-9.99% (0-0.999 volts), and the high range 0-99.9% (0-9.99 volts). For an output between 1 and 9.99 volts, the high range must be used. However, an output of less than 1 volt could be programmed with either range. Using only the high range makes programming slightly simpler, but range decoding provides for better resolution in the low end.

Figure 40 shows a method of implementing range decoding.

NOTE:

1. The programmed data word is converted into an integer. Decimal points are not allowed.
2. 0.5 is added to the word before the integer conversion, so the value will be rounded up if the first decimal place is 0.5 or greater.



NOTE:

1. The programmed data word is converted into an integer. Decimal points are not allowed.
2. 0.5 is added to the word before the integer conversion, so the value will be rounded up if the first decimal place is 0.5 or greater.

Figure 40. Range Decoding Flowchart.

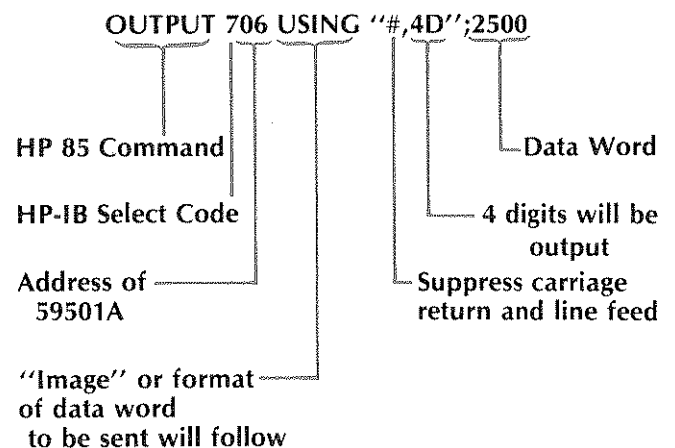
## B. Programming with Constants

**Note:** The 59501A-power supply combination must be calibrated before programming to avoid possible damage to the power supply.

### CV Power Supply Programming:

To set the output voltage of a 60 V supply to 30 V.

1. Compute  $30/60 = 50\%$ .
2. Program



### CC Power Supply Programming:

To set the output current of a 10 A supply to 0.661 A

1. Compute  $.661/10 = 6.61\%$
2. Program

**OUTPUT 706 USING "#,4D";1661**

### Low Level DC Signal Source:

To output 6.72 V, program

**OUTPUT 706 USING "#,4D";2672**

## D. Example Programs

```
10 ! 59501A UNIPOLAR
20 ! POWER SUPPLY PROGRAMMER
30 ! EXAMPLE PROGRAM
40 !
50 CLEAR
60 DISP "Enter the power supply's"
70 DISP "full scale output voltage."
80 INPUT F
90 IF F<0 THEN BEEP @ DISP "Negative voltage
not allowed." @ GOTO 60
100 !
110 DISP "Enter the desired output voltage."
120 INPUT V
130 IF V<0 THEN BEEP @ DISP "Negative voltage
not allowed." @ GOTO 110
140 !
150 ! Calculate percent of
160 ! power supply full scale
170 P=V/F*100
180 IF P>99.9 THEN BEEP @ DISP "Voltage too l
arge." @ GOTO 110
190 !
200 ! Select range
210 IF P>9.99 THEN GOTO 200
220 !
230 ! Low range calculations
240 M=INT(P*100+.5)
250 D=M+1000
260 GOTO 320
270 !
280 ! High range calculations
290 M=INT(P*10+.5)
300 D=M+2000
310 !
320 OUTPUT 706 USING "#,4D" ; D
330 DISP "The programmed data word is";D
340 GOTO 110
350 END
```

## C. Programming with Variables

Programming with variables allows the output value to be updated or changed with relative ease. The following programming examples may be entered into your HP 85 and run to demonstrate this type of programming. These programs ask for power supply output voltage, then scale that value up (or down) and calculate the correct 59501A programming word.

**NOTE:** The 59501A should be calibrated first, to obtain accurate output levels and avoid possible damage to the programmed power supply.

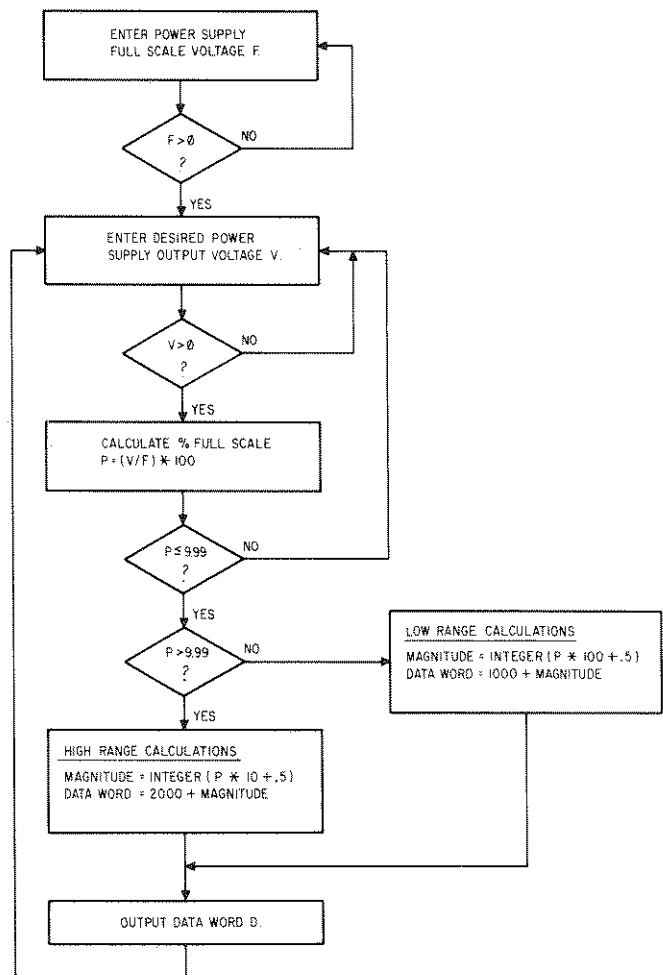


Figure 41. Unipolar Power Supply Programming Example.

```

10 ! 59501A BIPOLAR
20 ! POWER SUPPLY PROGRAMMER
30 ! EXAMPLE PROGRAM
40 !
50 CLEAR
60 DISP "Enter the power supply's"
70 DISP "positive full scale output"
80 DISP "voltage."
90 INPUT F
100 F=ABS(F)
110 !
120 DISP "Enter the desired output"
130 DISP "voltage (+or-). "
140 INPUT V
150 !
160 ! Convert bipolar voltage to
170 ! it's corresponding unipolar
180 ! value
190 U=(V+F)/2
200 IF U<0 OR U>=F THEN BEEP @ DISP "Voltage
too large." @ GOTO 120
210 !
220 ! Calculate percent of
230 ! Power supply full scale
240 P=U/F*100
250 IF P>99.9 THEN BEEP @ DISP "Voltage too l
arge." @ GOTO 120
260 !
270 ! Select range
280 IF P>9.99 THEN GOTO 350
290 !
300 ! Low range calculations
310 M=INT(P*100+.5)
320 D=M+1000
330 GOTO 390
340 !
350 ! High range calculations
360 M=INT(P*10+.5)
370 D=M+2000
380 !
390 OUTPUT 706 USING "#,4D" ; D
400 DISP "The programmed data word is";D
410 GOTO 120
420 END

```

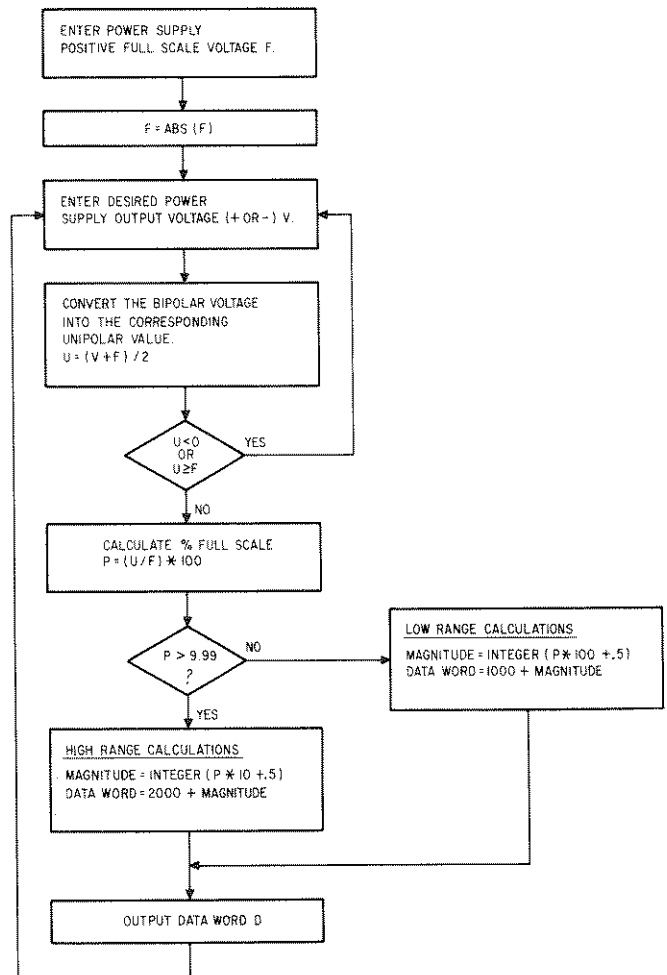


Figure 42. Bipolar Power Supply Programming Example.

## Signal Generation

The 59501A can easily be used to generate repetitive voltage waveforms. The following example computes the program data words, then generates a zero to ten volt sawtooth waveform.

```

10 ! Sawtooth Wave Generator
20 !
30 DIM N(100)
40 FOR J=1 TO 100
50 N(J)=(J-1)*10+2000
60 NEXT J
70 FOR J=1 TO 100
80 OUTPUT 706 USING "#,4D" ; N(J)
90 NEXT J
100 GOTO 70
110 END

```

Figure 43. D/A Mode Programming Example.

IEEE 488 interface functions implemented by the 59501A:

L2  
AH1

Figure 44. HP-IB Capabilities



---

For more information, call your local HP Sales Office or nearest Regional Office: Eastern (301) 258-2000; Midwestern (312) 255-9800; Southern (404) 956-1500; Western (213) 877-1282; Canadian (416) 678-9430. Ask the operator for instrument sales. Or write: Hewlett-Packard, 1501 Page Mill Road, Palo Alto, CA 94304. In Europe: Hewlett-Packard S.A., 7, rue du Bois-du-Lan, P.O. Box, CH 1217 Meyrin 2, Geneva, Switzerland. In Japan: Yokogawa-Hewlett-Packard Ltd., 29-21, Takaide-Higashi 3-chome, Suginami-ku, Tokyo 168.

59501-90003

PRINTED IN U.S.A.



## Free Manuals Download Website

<http://myh66.com>

<http://usermanuals.us>

<http://www.somanuals.com>

<http://www.4manuals.cc>

<http://www.manual-lib.com>

<http://www.404manual.com>

<http://www.luxmanual.com>

<http://aubethermostatmanual.com>

Golf course search by state

<http://golfingnear.com>

Email search by domain

<http://emailbydomain.com>

Auto manuals search

<http://auto.somanuals.com>

TV manuals search

<http://tv.somanuals.com>