

Overview

The HP StorageWorks family of Ultrium tape drives is HP's premier line of tape backup devices. Based on LTO Ultrium format, an open standard with a well-defined six-generation roadmap, HP Ultrium tape drives offer customers the best choice for investment protection. HP pioneered the half-height Ultrium drive, as the only manufacturer offering both full-height and half-height models of the first-generation Ultrium drives. While HP Ultrium half-height drives deliver the same capacity and the same level of reliability as our full-height Ultrium drives, they trade off lower performance for a much lower price, making them ideal for those who need the capacity and reliability of a superdrive without paying for the blazing speed of a full-height drive. The Ultrium 448 tape drive also matches the capacity and reliability features of the current second-generation full-height HP LTO tape drive, the Ultrium 460. With 20% less performance than the Ultrium 460, the Ultrium 448's features and pricing position it as the best value in the HP StorageWorks tape drive portfolio.

With ultimate reliability and ease of use in mind, even at a 100% duty cycle, HP's rugged design builds on superior LTO technology and adds advanced features to create a new level of data protection. HP Ultrium tape drives employ dynamic data rate matching to adjust to the speed of the host, reducing wear and tear on both drive and media and increasing performance, even on slower hosts. HP's ultra-durable soft-load feature automatically positions the data cartridge, and the highly reliable HP leader-capture mechanism virtually eliminates lost leaders, increasing the success of your backup and restore operations. Support for HP One-Button Disaster Recovery provides the easiest way to restore data in the event of a disaster. If data is critical to your business, protect it with an HP StorageWorks Ultrium tape drive.

What's New

- The new HP Ultrium 232 External Tape Drive, the most affordable LTO drive in the StorageWorks portfolio is now 100% RoHS compliant
- The new HP Ultrium 448 External Tape Drive, the fastest half-height LTO drive on the market:
 - features a new enclosure design
 - is 100% RoHS compliant

HP StorageWorks Ultrium 215

As the entry point for HP's Ultrium tape drive family, the HP StorageWorks Ultrium 215 tape drive offers superdrive capacity in a compact half-height form factor that makes it easy to integrate into workstations and servers. The Ultrium 215 is an LTO-1 drive that stores 200 GB of compressed data on a single tape at up to 54 GB per hour.

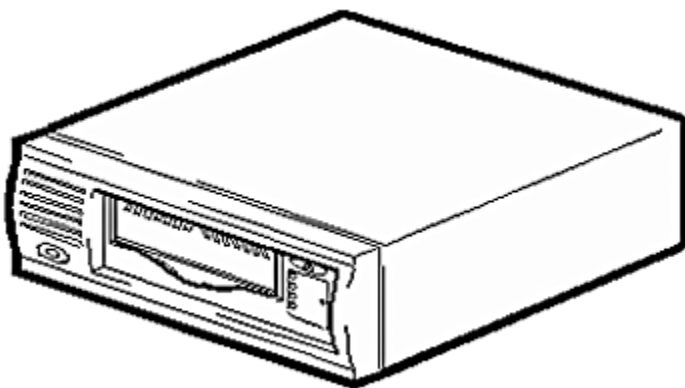

Ultrium 215 External Tape Drive

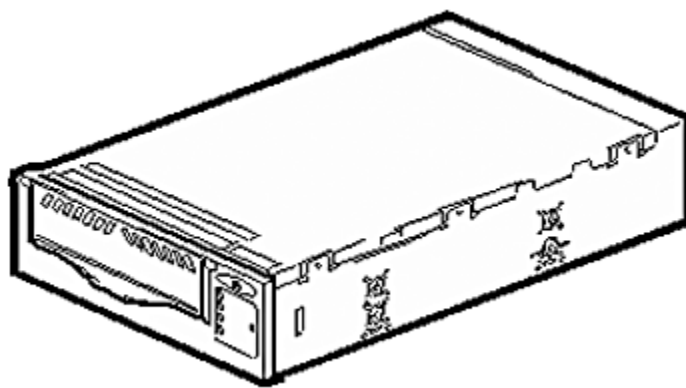

Ultrium 215 Internal Drive

Overview

HP StorageWorks Ultrium 232

The HP StorageWorks Ultrium 232 tape drive is the fastest LTO-1 drive in our portfolio. This affordable superdrive delivers enterprise-class capacity, performance, and reliability at a midrange price. With a compressed capacity of 200 GB per data cartridge and a compressed data transfer rate of 115 GB per hour, this LTO-1 drive is read- and write-compatible with all first-generation Ultrium drives and media, and its media can be read by any LTO-1, -2, or -3 drive from any manufacturer.

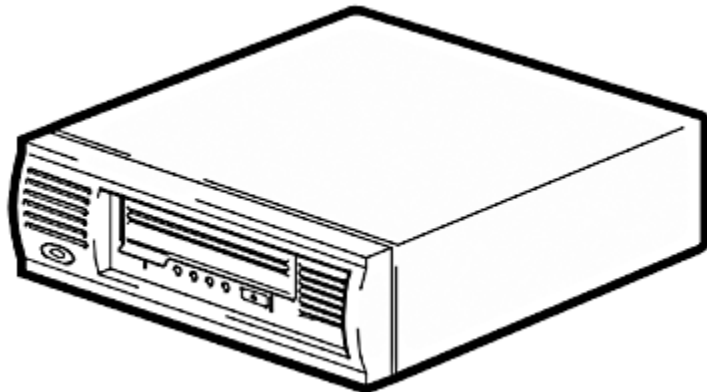

Ultrium 232 External Tape Drive

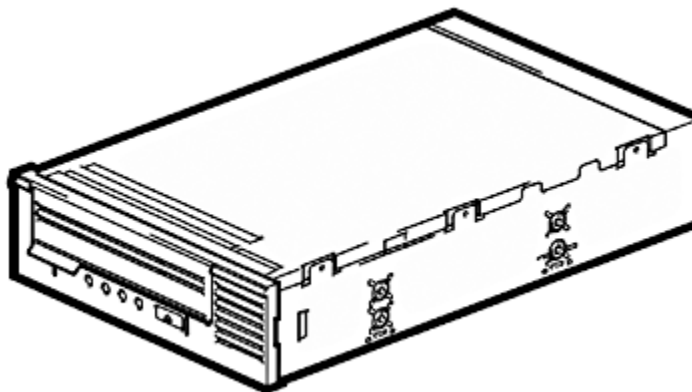

Ultrium 232 Internal Tape Drive

HP StorageWorks Ultrium 448

The HP StorageWorks Ultrium 448 tape drive is HP's second generation of half-height LTO tape drive technology. As the highest capacity, highest performance half-height drive in the StorageWorks family, the Ultrium 448 delivers a compressed storage capacity of 400 GB per data cartridge and a compressed data transfer rate of 172 GB per hour, more than three times as fast as the Ultrium 215 tape drive. The Ultrium 448 Tape Drive is fully read and write compatible with all first- and second-generation Ultrium drives and media. These features, combined with low pricing, make the Ultrium 448 the ideal direct-attach and network backup solution for entry-level and midrange servers where capacity and low cost of ownership are critical.

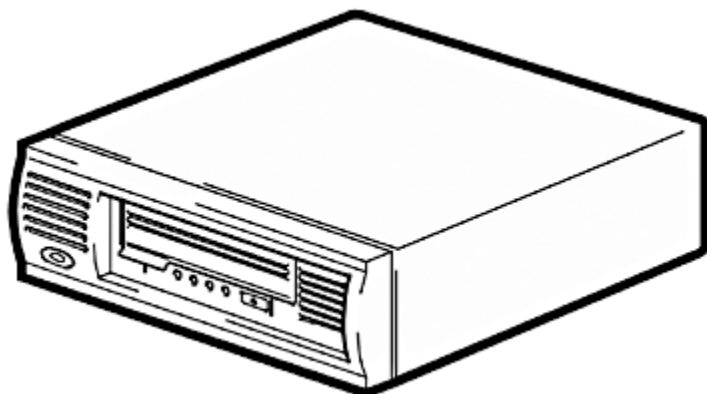

Ultrium 448 External Tape Drive

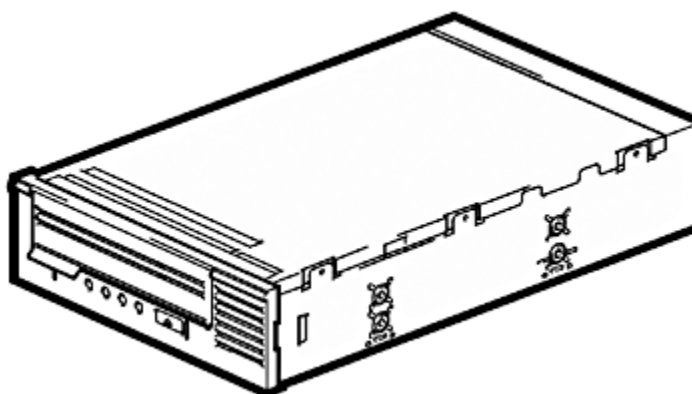

Ultrium 448 Internal Tape Drive

Models

Ultrium 215 Tape Drive	Ultrium 215 Internal (carbon)	Q1543A
	NOTE: 0D1 will appear after this part number on your sales order if factory integration is indicated.	
	Ultrium 215 External (carbon)	Q1545A
	Ultrium 215 Array Module (carbon)	C7492B*
	NOTE: Offline hot-swap tape drive for HP StorageWorks Tape Array 5300. *NOTE: 0D1 will appear after this part number on your sales order if factory integration is indicated.	
	Ultrium 215 Rack-mount (carbon)	350544-B21
NOTE: Single drive installed in a 3U Rack-mount kit		
Ultrium 215 Rack-mount (carbon)	A7444A	
NOTE: Single drive installed in a 1U Rack-mount kit		
<hr/>		
Ultrium 232 Tape Drive	Ultrium 232 Internal (carbonite)	DW064A
	NOTE: 0D1 will appear after this part number on your sales order if factory integration is indicated.	
	Ultrium 232 External (carbonite)	DW065B
<hr/>		
Ultrium 448 Tape Drive	Ultrium 448 Internal (carbonite)	DW016A
	NOTE: 0D1 will appear after this part number on your sales order if factory integration is indicated.	
	Ultrium 448 External (carbonite)	DW017B
	Ultrium 448 Array Module (carbonite)	DW019A*
	NOTE: Offline hot-swap tape drive for HP StorageWorks Tape Array 5300. *NOTE: 0D1 will appear after this part number on your sales order if factory integration is indicated.	
Ultrium 448 Rack-mount (carbonite)	DW028A*	
NOTE: Single drive installed in a 1U Rack-mount kit *NOTE: 0D1 will appear after this part number on your sales order if factory integration into a rack is indicated.		
<hr/>		

Key Features

- Affordable LTO technology
- Enterprise-class capacity and reliability
- Compact half-height form factor
- HP One-Button Disaster Recovery (OBDR) restores your entire system at the touch of a button
- High-capacity drives that store 200 GB or 400 GB of data on a single cartridge with 2:1 compression
- Data rate matching continuously adjusts the speed of the tape drive to that of the server or network environment, which increases performance, reduces mechanical wear on the drive, and extends tape life
- Fully read-and-write compatible with Ultrium drives and media from other manufacturers
- Includes a license to download a full, single-server copy of HP OpenView Storage Data Protector for Windows
- Includes HP StorageWorks Data Protector Express Single Server Edition backup/recovery software and the HP StorageWorks Data Protector Express Bare Metal Disaster Recovery option
- Active head cleaning provides automated cleaning that increases head life and reduces the need for using the cleaning cartridge
- Lower power consumption for maximum reliability at minimum cost
- Soft-load feature automatically takes the data cartridge and moves it into the load position
- Advanced tape leader capture design ensures fail-safe cartridge loading Internal, external, hot-swap, and rack-mounted models are available
- Includes HP StorageWorks Library and Tape Tools to help with installation, management, and troubleshooting

Models

Customer Benefits

Affordable	High capacity combined with low media cost delivers an exceptionally low cost of ownership
Compact	Half-height form factor saves space and fits in a wide range of servers and workstations
Dependable	Employs the same high standards for data integrity as HP's full-height Ultrium tape drives
High capacity	Stores all your data on a single cartridge
Fast	Minimizes network interruption and completes the backup within your backup window
Easy	Supports HP One-Button Disaster Recovery (OBDR), simply the easiest way to restore data in the event of a disaster
Manageable	Includes superior management capabilities that makes it easy to install, use and support
Well-connected	Compatible with leading operating systems, backup software and servers
Open	Based on LTO technology, which delivers the competitive benefits of an open format
Reliable	High-integrity data path including read and write DRAM protects your data

Product Highlights

LTO Ultrium Technology

Linear Tape-Open technology was developed by three leaders in the storage industry - HP, IBM, and Certance (now Quantum) - who brought together their combined expertise in tape technology to develop an entirely new format based on the best of existing technologies. Because LTO Ultrium technology was a new format, it required no cumbersome support of legacy formats, so it could be designed without compromising on reliability or performance. The LTO Program, a consortium of the three technology provider companies, has developed a well-defined six-generation roadmap, which has been executed right on schedule, with the first generation of Ultrium drives and media released in 2000, the second generation in 2002, and the third generation in 2004.

Ultrium 1 tape drive technology uses a linear format of 384 tracks, writing eight tracks simultaneously. Ultrium 2 tape drive technology uses a linear format of 512 tracks, writing eight tracks simultaneously. The data is written in a serpentine pattern; the tape reverses direction after each set of eight tracks is written. This provides higher density recording, enabling customers to lower costs and increase efficiency by storing more data on a single tape in an industry standard format.

The LTO standard for backward compatibility is to write back one generation and read back two generations; therefore:

- First-generation Ultrium drives, such as HP Ultrium 232, read and write LTO 1 media
- Second-generation Ultrium drives, such as HP Ultrium 460 and Ultrium 448, read and write LTO 1 and LTO 2 media.
- Third-generation Ultrium drives, such as the new Ultrium 960, read and write LTO 2 and LTO 3 media and also read LTO 1 media.

As part of the LTO open standard, all HP tape drives and media offer the same standards of compatibility with tape drives and media manufactured by other LTO vendors.

LTO data compression (LTO-DC) is an enhanced version of Advanced Lossless Data Compression (ALDC) hardware compression. Compression is automatically turned off if the compressed data would cause an overall expansion in data size, hence optimizing the available capacity on the media. This system is used in Ultrium generation 1, 2, and 3 products.

The decision about what next technology you should buy into should be based on your future, not your past, investment. Choose the Ultrium format when you need the following advantages:

- Maximum reliability, capacity and performance
- Compatibility with a broad range of operating systems and servers (e.g., a mixed system environment)
- A legacy-free technology that uses the best attributes from a wide range of tape technologies without any compromises for backward compatibility requirements
- A solid roadmap for future generations of the technology
- An open format available from multiple vendors
- Lowest media cost of any 'superdrive' tape technology

Data Rate Matching

An exclusive feature of HP Ultrium tape drives, data rate matching allows the tape drive to adjust its transfer rate to the speed of host dynamically and continuously. This feature, coupled with the Ultrium buffer management technology within the data path, ensures that the tape drive continues to stream data, reducing the need to rewind the tape back and forth to wait for the host. This feature brings two big advantages:

- It optimizes performance, getting the best performance possible for the environment, regardless of the speed of the host or the network.
- It reduces wear and tear on drive and media, thus increasing reliability.

Product Highlights

Software in the Box

The HP StorageWorks Ultrium tape drives include HP StorageWorks Data Protector Express Single Server Edition backup/recovery software and the HP StorageWorks Data Protector Express Bare Metal Disaster Recovery option. Data Protector Express Single Server Edition is an easy-to-use backup application to protect a single Windows, Linux or NetWare server. The Data Protector Express Bare Metal Disaster Recovery (BMDR) option provides automated system recovery of that server following a major hardware or software failure. The fastest method to recovery the server is to use the Data Protector Express BMDR option and the One Button Disaster Recovery feature of the HP StorageWorks Ultrium tape drives.

As well as getting the Data Protector Express Single Server Edition software as part of the HP StorageWorks Ultrium tape drives solution, purchasers can also upgrade to the class-leading Data Protector Express backup/recovery software. This is a special SKU, only available for new customers of HP StorageWorks tape products that gives a significant discount off Data Protector Express to recognise the value of the in-box software. Upgrading to Data Protector Express allows network backup of servers and Windows desktops, extends the disk-to-disk backup capacity and capability and permits the additions of agents and extensions to increase scale and performance of the backup infrastructure. For more information about the the in-box software please visit <http://www.hp.com/go/dataprotectorexpress/sse>.

If the HP StorageWorks Ultrium tape drive is for a large environment that requires UNIX support and/or enterprise class application and feature support then HP OpenView Storage Data Protector is the recommended backup/recovery software. For more information and evaluation software please visit <http://www.hp.com/go/dataprotector>.

HP Ultrium Storage Media

HP recommends that you use HP-branded cartridges in your HP Ultrium tape drive to assure the highest level of protection for your valuable data. Our test program for HP Ultrium media is the most thorough and comprehensive in the industry.

All HP cartridges must satisfy an exhaustive battery of additional tests that relate directly to real life situations, where real data and real businesses are at stake. The benefit of the HP brand specification for media is consistent quality. Through the testing of thousands of HP drives and HP cartridges, the ideal formulation for backup performance is defined and then continuously monitored. This hugely resource-intensive process is unique to HP and affords deep insight into the HP+HP backup solution for a wide range of environments and duty cycles. Your best choice for ease of support and maximum dependability is to use HP-branded Ultrium cartridges at all times.

Management

HP Ultrium tape drives and automation are supported by HP StorageWorks Library and Tape Tools (LTT). This set of easy-to-use utilities makes the installation and maintenance of HP tape drives and devices simple:

- Verifies installation of the drive
- Tests and verifies the health of the drive and media
- Provides HP support with detailed device information
- Offers multiple options for finding and upgrading new firmware
- Aids in performance optimization
- Included with each Ultrium tape drive and available via free download supporting all HP tape products

Instructions and downloads of Library and Tape Tools are available at: http://www.hp.com/country/us/eng/software_drivers.html

Product Highlights

HP One-Button Disaster Recovery (OBDR)

HP StorageWorks One-Button Disaster Recovery is an exclusive feature of HP tape drives that provides fast and simple disaster recovery on HP ProLiant servers. OBDR is a firmware-driven utility that can restore a server's operating system, software applications, and data using a single tape cartridge. Depending on the size of the data set, OBDR can provide system recovery in less than one hour, reducing the recovery window by more than 50 percent and minimizing the risks and costs associated with downtime. There's no longer a need to search for software disks and manuals or make a new set of disaster recovery disks each time the network configuration is altered or a peripheral is added. The sheer simplicity of OBDR means less human error. Backup and disaster recovery preparation, previously two separate tasks, now become one process. For more information about OBDR, visit the HP website at <http://www.hp.com/go/obdr>.

For a current list of servers, workstations, and software that support OBDR, check the tape backup compatibility pages on the HP website at: <http://www.hp.com/go/connect>.

Compatibility

HP's extensive compatibility testing program assures that your HP StorageWorks Ultrium tape drive works with leading servers, operating systems, and backup applications - and not just those sold by HP. HP Ultrium tape drives work seamlessly on many platforms, making them especially suitable if you have a mixed system environment. For the latest list of servers, workstations, operating systems, and backup software that support HP Ultrium tape drives, check the tape backup compatibility pages on our Web site at: <http://www.hp.com/go/connect>.

HP Server Compatibility

HP StorageWorks Ultrium tape drives are supported on the following classes of HP systems:

- HP ProLiant DL servers
- HP ProLiant ML servers
- HP Integrity servers
- HP 9000 servers
- HP workstations

HP StorageWorks Ultrium tape drives are also supported on server platforms from third-party manufactures including:

- Dell
- IBM
- Sun

For details of which tape drive models work with which systems, including third-party systems, visit <http://www.hp.com/go/connect> for the latest hardware compatibility information.

Cables and Termination

All cables required for internal and external connection to HP servers are provided with your tape drive. For non-HP servers, please consult your manufacturers' server specifications to determine if the cable provided with your Ultrium tape drive is appropriate for use with that server. No terminator is required for internal models (assumes use of terminated cable). The external model features "auto-termination" - no terminator is required.

Performance Tuning

You will need to connect the drive to a dedicated SCSI Host Bus Adaptor (HBA) or integrated SCSI interface that is Ultra 160 or higher. Please reference the "Options" section of these QuickSpec for all supported SCSI adapters and interfaces.

To achieve full performance with your tape drive, do not use the native backup application within the operating system (e.g., NT® Backup, Windows® 2000 Backup). For full details of supported backup applications, please visit: <http://www.hp.com/go/connect>

OS Support

Microsoft® Windows, Novell NetWare, HP-UX, Red Hat Linux, United Linux, IBM-AIX, Sun Solaris and other operating systems.

NOTE: Please visit <http://www.hp.com/go/connect> for the latest compatibility information.

Backup Software Support

All HP Ultrium tape drives are qualified with HP OpenView Storage Data Protector, HP StorageWorks Data Protector Express, VERITAS Backup Exec, BrightStor ARCserve IT, Yosemite TapeWare, Legato Networker, Dantz Retrospect, Tivoli TSM, NovaBackup, and other backup applications

NOTE: Please visit <http://www.hp.com/go/connect> for the latest compatibility information.

Service and Support, HP Care Pack, and Warranty Information

HP Care Pack Information

HP Care Pack Services offer upgraded service levels to extend and expand your standard product warranty with easy-to-buy, easy-to-use support packages that help you make the most of your hardware and software investments. They let you choose the support levels that meet your business requirements, from basic to mission-critical. They help you contain total cost of ownership.

HP Care Pack warranty extensions can be purchased along with HP products to cost-effectively upgrade or extend your warranty. For many products, post-warranty HP Care Pack services are available when your original warranty has expired.

Why purchase an HP Care Pack service?

Your standard warranty protects against product defects. HP Care Pack Services help you guard against unplanned downtime, which can reduce your productivity and profitability. These convenient service packages:

- Protect your investment in HP products
- Provide consistent, predictable levels of support across your entire department or business
- Ease budget planning with fixed-cost support that includes parts and labor
- Give you direct access to proven technical and problem-solving expertise
- Offer a choice of response-time and repair-time commitments
- Deliver prompt, measurable results
- Are available whenever and wherever you do business

HP Care Pack availability may vary by country and product.

Supporting your Adaptive Enterprise journey

HP Services helps you make the Adaptive Enterprise real for your organization. The breadth, depth, and quality of HP hardware and software support services can help you improve the performance of your IT support processes and resolve the complex software and hardware problems that tax user productivity. HP Care Pack services help you increase IT environment stability, efficiency, and agility from the desktop to the data center, and improve the productivity of your employees.

Warranty and Services Included with the Product

Hewlett-Packard provides a 3-year, next-day, parts exchange, limited warranty for the Ultrium tape drive (Warranty Code 7Z), plus 9x5 phone support for the duration of the warranty.

For more information about HP's Global Limited Warranty and Technical Support, visit: ftp://ftp.compaq.com/pub/products/storageworks/warranty/EN_321708-008.pdf

Service and Support, HP Care Pack, and Warranty Information

Recommended Services

In order to maximize ROI and product uptime, and minimize the cost of ownership, Hewlett Packard recommends:

3 years 24 x 7 Hardware Support

- Guards against downtime, which reduces productivity and profitability
- Eases budget planning with fixed-cost support that includes parts and labor
- Direct access to proven technical and problem-solving expertise
- 3 years 24 x 7 Software Support
- Improve the productivity of system managers and operators
- Improve system performance and reduce downtime due to software defects
- Expedite problem resolution through expert-level technical resources
- Enjoy consistent service coverage across geographically dispersed sites
- Update HP and selected third-party software at a predictable cost
- Take advantage of subscription savings on software updates
- Keep your license compliancy up-to-date

Available HP Care Pack Services

Extend your product warranty with a wide choice of cost-saving support packages.

HP Care Pack services are sold by HP and HP authorized enterprise and commercial resellers. Services for customers purchasing via direct and enterprise resellers are quoted using HP order configuration tools. Additional information about HP Care Pack service features and benefits is available at <http://www.hp.com/hps/carepack/services/>.

Key for HP Care Pack service availability in the table below:

E = Service available for customers purchasing direct and via enterprise resellers

C = Service available for customers purchasing via commercial resellers

N/A = Service not applicable

HP Care Pack Services Deployment and Per Event Services	Service Available
HP Installation	E/C
HP Installation & Startup	N/A
HP Implementation	N/A

For more information about deployment and per event services for HP storage products, visit <http://www.hp.com/hps/storage/>.

Service and Support, HP Care Pack, and Warranty Information

HP Care Pack Services Availability Services	1 yr	3 yr	4 yr	5 yr
HP Next Day Hardware Support	E/C	E/C	C	C
HP 4 Hr, 9x5 HW Support	E/C	E/C	C	C
HP 4 Hr, 13x5 Hardware Support	E/C	E/C	C	C
HP 4 Hr, 24x7 Hardware Support	E/C	E/C	C	C
HP 6 HR Call-to-Repair HW Support	E/C	E/C	C	C
HP Software Support	E/C	E/C	C	C
HP Software Support 24x7	E/C	E/C	C	C
HP Support Plus	E/C	E/C	C	C
HP Support Plus 24	E/C	E/C	C	C
HP Proactive Essentials 9x5, 10 SW Incidents	NA	NA	NA	NA
HP Proactive Essentials 9x5, 25 SW Incidents	NA	NA	NA	NA
HP Proactive Essentials 9x5 Unlimited	NA	NA	NA	NA
HP Proactive Essentials 24x7, 25 SW Incidents	NA	NA	NA	NA
HP Proactive Essentials 24x7, 50 SW Incidents	NA	NA	NA	NA
HP Proactive Essentials 24x7 Unlimited	NA	NA	NA	NA
HP Proactive 24 Service*	NA	NA	NA	NA
HP Critical Service*	NA	NA	NA	NA

To find HP Care Pack Services available via HP authorized commercial resellers, visit http://h30125.www3.hp.com/csn/salesmktg/elfpack/elf_nonlkup_ctrylang.asp?code=ELNL

Deployment and Per Event Service Descriptions

Installation is part of a suite of HP deployment services that are designed to provide a quick response to your need for additions to your organization's IT infrastructure, while giving you the peace of mind that comes from good knowing your hardware and software products from HP and selected third parties have been installed in a professional manner by a highly skilled HP service delivery specialist.

HP Installation Service

- Expedited installation, with all service prerequisites met before the installation is performed
- Installation in accordance with manufacturer's specifications, enhancing the supportability of your HP-installed hardware and software
- Service delivery at a mutually scheduled time Allows your IT resources to stay focused on their core tasks and priorities
- Availability of an HP service specialist to answer questions during the onsite delivery of this service
- Service planning
- Service deployment
- Installation verification tests

HP Care Pack Service Enterprise & Commercial Purchased Care Packs

Product Numbers ('A' stands for physical Care Pack, 'E' for electronic Care Pack)

Service and Support, HP Care Pack, and Warranty Information

Product Number	Product Description
U2090A/E	Tape Installation HW Installation Only
H3157A/E	HW, "3-year", "Next Business Day", "9x5", "on-site"
H4617A/E	HW, "3-year", "4-hour", "13x5", "on-site"
H4622A/E	HW, "3-year", "4-hour", "24x7", "on-site"
U6359A/E	HW, "3-year", "6hr Call to Repair", "24x7", "on-site"
U9342A/E	HW, "4-year", "4-hour", "13x5", "on-site"
U9343A/E	HW, "4-year", "4-hour", "24x7", "on-site"
U9344A/E	HW, "5-year", "4-hour", "13x5", "on-site"
U9345A/E	HW, "5-year", "4-hour", "24x7", "on-site"
UA454PE	HW, "1-year", "Next Business Day", "9x5", "on-site", "Post Warranty"
UA455PE	HW, "1-year", "4-hour", "13x5", "on-site", " Post Warranty "
UA456PE	HW, "1-year", "4-hour", "24x7", "on-site", " Post Warranty "
UA457PE	HW, "1-year", "6hr Call to Repair", "24x7", "on-site", Post Warranty"

Enterprise Purchased Care Packs

Product Number	Product Description	Drive Band	Install Band
HA113A1	Tape Installation HW Installation Only	N/A	596
HA101A3	HW, "3-year", "next-day", "13x5", "on-site"	450	N/A
HA103A3	HW, "3-year", "4-hour", "13x5", "on-site"	450	N/A
HA104A3	HW, "3-year", "4-hour", "24x7", "on-site"	450	N/A
HA105A3	HW, "3-year", "6hr CTR", "24x7", "on-site"	450	N/A
HA106A3	SW, "3-year", "Phone-in", "9x5"	N/A	N/A
HA107A3	SW, "3-year", "Phone-in", "24x7"	N/A	N/A
HA109A3	HW Only, Support Plus, "3-year", "13x5"	450	N/A
HA110A3	HW Only, Support Plus 24, "3-year", "24x7"	450	N/A
HA111A3	HW Only, Proactive 24, "3-year", "24x7"	450	N/A
HA112A3	HW Only, Critical Service, "3-year", "24x7"	450	N/A

NOTE:

* Both Proactive 24 & Critical Service only relate to 'reactive elements', 'proactive elements' are available on time & materials basis. (SW is supported separately per package).

The Care Pack information quoted above relates to 3-year offerings only; 1-year, 4-year, and 5-year packs are available for each offering (replace A3 with A1, A4 or A5).

Service and Support, HP Care Pack, and Warranty Information

eSupport

HP eSupport is a portfolio of technology-based services that assist you with managing your business environment - from the desktop to the data center.

Support Portal

The HP support portal provides one-stop access to the information, tools and services you need to manage the daily operations of your IT environment.

Features include:

- Access to self-solve tools (including search technical knowledge base)
- Efficient logging and tracking of support cases
- Collaboration with other business and IT professionals
- Download of patches and drivers
- Access to diagnostic tools
- Proactive notification of relevant information

Access to certain features of the support portal requires an HP service agreement. To access the support portal, visit <http://www.hp.com/support>.

HP Education Services For more information about HP Education Services for Storage and SAN, visit <http://education.hp.com/curr-storsan.html>

Additional Services Information

For more information about Deployment, Per Event, Consulting and Education services for HP Storage, visit: <http://www.hp.com/hps/storage/>

For more information about HP Care Pack services for storage products, visit: http://www.hp.com/hps/carepack/storage/cp_networked.html

For more information about HP storage software, services and updates, visit: <http://h18006.www1.hp.com/storage/software.html>

If you have specific questions, contact your local HP representative. Contact information for a representative in your area can be found at "Contact HP" <http://www.hp.com/>

Options

Host Bus Adapters, Controllers, and Accessories for ProLiant Servers	Smart Array 6i Controller (integrated on system board)	N/A
	NOTE: This controller is integrated only on HP ProLiant DL380 G4 servers.	
	Integrated Single Channel Ultra320 SCSI Controller	N/A
	NOTE: This controller is integrated on HP ProLiant ML330 G3 server.	
	Integrated Dual Channel Ultra320 SCSI Controller	N/A
Host Bus Adapters, Controllers, and Accessories for HP PA-RISC and IPF servers	NOTE: This controller is integrated on HP ProLiant ML350 G3, HP ProLiant ML350 G4, HP ProLiant ML 370 G3, HP ProLiant ML370 G4, HP ProLiant ML530 G2, and HP ProLiant ML570 G2 servers.	
	64-Bit/133-MHz Dual Channel Ultra320 SCSI Adapter	268351-B21
	64-Bit/133-MHz Single Channel Ultra320 SCSI HBA G2	374654-B21
	NOTE: This controller may also be used for connecting HP Ultrium tape drives to 3rd party server platforms such as Dell, IBM, and Sun. Please refer to the HP Tape Backup Products Compatibility website at http://www.hp.com/go/connect for more information.	
	64-Bit/66-MHz Dual Channel Wide Ultra3 SCSI Adapter, Alternate OS	284688-B21
Host Bus Adapters, Controllers, and Accessories for HP AlphaServers	NOTE: This SCSI host bus adapter supports the following operating systems: OpenUNIX, Solaris, OS/2, Novell NetWare 3.2/4.2/5, Unixware 2.x/7.x. Some of these operating systems may not be supported on other HP Ultra320 SCSI host bus adapters. Please check the appropriate controller QuickSpecs for support details.	
	64-Bit/133-MHz Dual Channel Ultra320 SCSI Adapter	A7173A
	64-Bit/66-MHz Dual Channel Ultra3 SCSI Adapter	A6829A
	NOTE: For maximum tape drive performance, HP recommends the Ultra320 SCSI adapter for use with the Ultrium 960 tape drive.	
Host Bus Adapters for Third-Party Servers	64-Bit/66-MHz Single Channel Ultra3 SCSI Adapter	A6828A
	NOTE: For maximum tape drive performance, HP recommends the Ultra320 SCSI adapter for use with the Ultrium 960 tape drive.	
	Please refer to the HP Tape Backup Products Compatibility website at http://www.hp.com/go/connect for more information on support for HP PA-RISC and IPF servers.	
Host Bus Adapters, Controllers, and Accessories for HP AlphaServers	32-Bit PCI to Single Channel Wide-Ultra2 SCSI Adapter	3X-KZPCA-AA
	Triple-Function Combo Adapter: LVD / SCSI II, 10/100 UTP Ethernet, and 2D Graphics	3X-DEPVZ-AA
	Dual Channel 64/66-MHz PCI-to-SCSI Ultra160 Host Bus Adapter	3X-KZPEA-DB
Host Bus Adapters for Third-Party Servers	64-Bit/133-MHz Single Channel Ultra320 SCSI HBA G2	374654-B21
	NOTE: This SCSI controller supports a wide range of connectivity to non-HP 32-bit servers. Please refer to the HP Tape Backup Products Compatibility website at http://www.hp.com/go/connect for more information on support for non-HP 32-bit server platforms using your HP Ultrium tape drive.	
	HP Ultrium tape drives are supported on a wide range of non-HP server using third-party SCSI controllers and host bus adapters. NOTE: Please refer to the HP Tape Backup Products Compatibility website at http://www.hp.com/go/connect for more information on Ultrium support for non-HP servers using third-party controllers and adapters.	

Options

Media	HP Ultrium 400 GB Data Cartridge (recommended for Ultrium 448)	C7972A
	HP Ultrium 200 GB Storage Media Kit	C8013A
	HP Ultrium 400 GB Storage Media Kit	C8014A
	HP Ultrium Universal Cleaning Cartridge	C7978A

Rack-mount Options	1U Rack-mount Kit	A7445B
	<p>NOTE: For racked ProLiant servers. No drives included. Accommodates up to two internal half-height drives (such as the Ultrium 232 and Ultrium 448).</p> <p>NOTE: Please refer to web page for further information: http://h18006.www1.hp.com/products/storageworks/1urackmount/index.html</p>	
	3U Rack-mount Kit	274338-B22
	<p>NOTE: For racked ProLiant servers. No drives included. Accommodates up to four internal half-height drives (such as the Ultrium 232 or Ultrium 448) or two full-height drives (such as the Ultrium 460 or Ultrium 960).</p> <p>NOTE: Please refer to web page for further information: http://h18006.www1.hp.com/products/storageworks/3urackmount/index.html</p>	
	Tape Array 5300	C7508B*
	<p>NOTE: For racked HP-UX or ProLiant servers and other industry-standard racks. Holds up to four offline hot-swap half-height drives (such as the Ultrium 232 array module or a DVD-ROM drive) or up to two offline hot-swap full-height drives (such as the Ultrium 460 or Ultrium 960 array modules).</p> <p>NOTE: Please refer to web page for further information: http://www.hp.com/products1/storage/products/tapebackup/tapearrays/tapearray5300/index.html</p>	
	* NOTE: For the factory racked version, please order C7508AZ	
	Redundant, hot-swap power supply and fan for Tape Array 5300	C7496B

Software	Data Protector Express backup/recovery software	BB117AT
-----------------	---	---------

Cables and Adapters	68-pin HD/68-pin VHDCI, 12 ft/3.66 m SCSI cable for external drives	341177-B21
	68-pin HD/68-pin HD, 16.40 ft/5 m SCSI cable for external drives	328215-001
	68-pin HD/68-pin HD, 32.81 ft/10 m SCSI cable for external drives	328215-002
	68-pin HD/VHDCI LVD SCSI cable kit (for use with 3U Rack-mount Kit)	168048-B21
	68-Pin HD/68-Pin HD SCSI cable kit (for use with 3U Rack-mount Kit)	242381-B21
	1.5m external SCSI cable (68-pin high density to 68-pin high density, LVD/SE)	C5742A
	68-pin HD to 68-pin VHD, LVD/SE Ultra2 SCSI adapter plug	C7434A

Kit Contents

Model Name	Kit Contents Description	Part Number
Ultrium 215 tape drives		
Ultrium 215 Internal (carbon)	<p>HP StorageWorks Ultrium 215 Internal Tape Drive; HP StorageWorks Tape CD-ROM (contains HP StorageWorks Library and Tape Tools utilities and localized user manuals); HP StorageWorks Data Protector Express Single Server Edition backup/recovery software CD and the HP StorageWorks Data Protector Express Bare Metal Disaster Recovery option; HP Ultrium 1 Data Cartridge (200 GB); Ultrium Cleaning Cartridge; internal SCSI cable; multi-language labels; mounting rails for HP ProLiant ML350 and ML370 servers; performance tuning poster; documentation.</p> <p>NOTE: 0D1 will appear after this part number on your sales order if factory integration is indicated.</p>	Q1543A

Options

Ultrium 215 External (carbon)	HP StorageWorks Ultrium 215 External Tape Drive; HP StorageWorks Tape CD-ROM (contains HP StorageWorks Library and Tape Tools utilities and localized user manuals); HP StorageWorks Data Protector Express Single Server Edition backup/recovery software CD and the HP StorageWorks Data Protector Express Bare Metal Disaster Recovery option; HP Ultrium 1 Data Cartridge (200 GB); Ultrium Cleaning Cartridge; multi-language labels; power cord; 68-pin HD to 68-pin VHDCI multi-mode SCSI cable (5183-2675); performance tuning poster; documentation.	Q1545A
Ultrium 215 Array Module (carbon) - works with HP StorageWorks Tape Array 5300)	HP Ultrium 215 offline hot-swap array module; HP StorageWorks Tape CD-ROM (includes HP StorageWorks Library and Tape Tools utilities and localized user manuals); HP StorageWorks Data Protector Express Single Server Edition backup/recovery software CD and the HP StorageWorks Data Protector Express Bare Metal Disaster Recovery option; HP Ultrium 1 Data Cartridge (200 GB); Ultrium Cleaning Cartridge; multi-language labels; documentation.	C7492B
Ultrium 215 Rack-mount (carbon) - single drive installed in a 1U Rack-mount kit	Wide SCSI LVD rack-mountable enclosure (1U) with power supply and fan; rail kit; one internal Ultrium 215 tape drive; power cord; HP StorageWorks Tape CD-ROM (contains HP StorageWorks Library and Tape Tools utilities and localized user manuals); HP StorageWorks Data Protector Express Single Server Edition backup/recovery software CD and the HP StorageWorks Data Protector Express Bare Metal Disaster Recovery option; HP Ultrium 1 Data Cartridge (200 GB); Ultrium Cleaning Cartridge; multi-language labels; documentation.	A7444A
Ultrium 215 Rack-mount (carbon) - single drive installed in a 3U Rack-mount kit	Wide SCSI LVD rack-mountable enclosure (3U) with power supply and fan; one internal Ultrium 215 Tape Drive; power cord; HP StorageWorks Tape CD-ROM (contains HP StorageWorks Library and Tape Tools utilities and localized user manuals); HP StorageWorks Data Protector Express Single Server Edition backup/recovery software CD and the HP StorageWorks Data Protector Express Bare Metal Disaster Recovery option; HP Ultrium 1 Data Cartridge (200 GB); Ultrium Cleaning Cartridge; multi-language labels; documentation	350544-B21
Ultrium 232 tape drives		
Ultrium 232 Internal (carbonite)	HP StorageWorks Ultrium 232 Internal Tape Drive; HP StorageWorks Tape CD-ROM (contains HP StorageWorks Library and Tape Tools utilities and localized user manuals); HP StorageWorks Data Protector Express Single Server Edition backup/recovery software CD and the HP StorageWorks Data Protector Express Bare Metal Disaster Recovery option; HP Ultrium 1 Data Cartridge (200 GB); internal SCSI cable; documentation. NOTE: 0D1 will appear after this part number on your sales order if factory integration is indicated.	DW064A
Ultrium 232 External (carbonite)	HP StorageWorks Ultrium 232 External Tape Drive; HP StorageWorks Tape CD-ROM (contains HP StorageWorks Library and Tape Tools utilities and localized user manuals); HP StorageWorks Data Protector Express Single Server Edition backup/recovery software CD and the HP StorageWorks Data Protector Express Bare Metal Disaster Recovery option; HP Ultrium 1 Data Cartridge (200 GB); power cord; 68-pin HD to 68-pin VHDCI multi-mode SCSI cable; documentation.	DW065B
Ultrium 448 tape drives		
Ultrium 448 Internal (carbonite)	HP StorageWorks Ultrium 448 Internal Tape Drive; HP StorageWorks Tape CD-ROM (contains HP StorageWorks Library and Tape Tools utilities and localized user manuals); HP StorageWorks Data Protector Express Single Server Edition backup/recovery software CD and the HP StorageWorks Data Protector Express Bare Metal Disaster Recovery option; HP Ultrium 2 Data Cartridge (400 GB); internal SCSI cable; documentation. NOTE: 0D1 will appear after this part number on your sales order if factory integration is indicated.	DW016A

Options

Ultrium 448 External (carbonite)	HP StorageWorks Ultrium 448 External Tape Drive; HP StorageWorks Tape CD-ROM (contains HP StorageWorks Library and Tape Tools utilities and localized user manuals); HP StorageWorks Data Protector Express Single Server Edition backup/recovery software CD and the HP StorageWorks Data Protector Express Bare Metal Disaster Recovery option; HP Ultrium 2 Data Cartridge (400 GB); power cord; 68-pin HD to 68-pin VHDCI multi-mode SCSI cable; documentation.	DW017B
Ultrium 448 Array Module (carbonite) - works with HP StorageWorks Tape Array 5300	HP Ultrium 448 offline hot-swap array module; HP StorageWorks Tape CD-ROM (includes HP StorageWorks Library and Tape Tools utilities and localized user manuals); HP StorageWorks Data Protector Express Single Server Edition backup/recovery software CD and the HP StorageWorks Data Protector Express Bare Metal Disaster Recovery option; HP Ultrium 2 Data Cartridge (400 GB); documentation. NOTE: 0D1 will appear after this part number on your sales order if factory integration is indicated.	DW019A
Ultrium 448 Rack-mount (carbonite) - single drive installed in a 1U Rack-mount kit	Wide SCSI LVD rack-mountable enclosure (1U) with power supply and fan; rail kit; one internal Ultrium 448 tape drive; power cord; HP StorageWorks Tape CD-ROM (contains HP StorageWorks Library and Tape Tools utilities and localized user manuals); HP StorageWorks Data Protector Express Single Server Edition backup/recovery software CD and the HP StorageWorks Data Protector Express Bare Metal Disaster Recovery option; HP Ultrium 2 Data Cartridge (400 GB); documentation. NOTE: 0D1 will appear after this part number on your sales order if factory integration into a rack is indicated.	DW028B

Technical Specifications

		Ultrium 215	Ultrium 232	Ultrium 448	
Dimensions	Form Factor	5¼-inch half-height	5¼-inch half-height	5¼-inch half-height	
	Physical (HxWxD) Internal	1.6 x 5.7 x 8.9 in (4.0 x 14.5 x 22.5 cm)	1.6 x 5.7 x 8.1 in (4.1 x 14.5 x 20.6 cm)	1.6 x 5.7 x 8.1 in (4.1 x 14.5 x 20.6 cm)	
	Physical (HxWxD) External	2.75 x 8.19 x 11.5 in (7.0 x 20.8 x 29.2 cm)	3 x 8.8 x 11.7 in (7.7 x 22.3 x 29.5 cm)	3 x 8.8 x 11.7 in (7.7 x 22.3 x 29.5 cm)	
	Physical (HxWxD) Array Module	1.7 x 6.3 x 11.2 in (4.3 x 16 x 28.5 cm)	N/A	1.7 x 6.3 x 11.2 in (4.3 x 16 x 28.5 cm)	
	Physical (HxWxD) 1U Rack-mount	1.70 x 16.88 x 25.25 in (4.32 x 42.88 x 64.14 cm)	N/A	1.7 x 16.88 x 25.25 in (4.32 x 42.88 x 64.14 cm)	
	Physical (HxWxD) 3U Rack-mount	5.2 x 16.8 x 23.0 in (13.2 x 42.7 x 58.4 cm)	N/A	N/A	
	Shipping (HxWxD) Internal	11.4 x 17.7 x 12.2 in (29.0 x 45.0 x 31.0 cm)	11.4 x 17.7 x 12.2 in (29.0 x 45.0 x 31.0 cm)	11.4 x 17.7 x 12.2 in (29.0 x 45.0 x 31.0 cm)	
	Shipping (HxWxD) External	15.4 x 18.7 x 15.4 in (39.0 x 47.5 x 39.0 cm)	15.4 x 18.7 x 15.4 in (39.0 x 47.5 x 39.0 cm)	15.4 x 18.7 x 15.4 in (39.0 x 47.5 x 39.0 cm)	
	Physical (HxWxD) Array Module	11.4 x 17.7 x 12.2 in (29.0 x 45.0 x 31.0 cm)	N/A	11.4 x 17.7 x 12.2 in (29.0 x 45.0 x 31.0 cm)	
	Shipping (HxWxD) 1U Rack-mount	12.0 x 23.5 x 33.5 in (30.5 x 59.7 x 85.1 cm)	N/A	12.0 x 23.5 x 33.5 in (30.5 x 59.7 x 85.1 cm)	
	Shipping (HxWxD) 3U Rack-mount	15.75 x 23.75 x 33.5 in (40.0 x 60.3 x 85.1 cm)	N/A	N/A	
	Weight	Out of box, Internal	3.2 lb (1.45 kg)	3.2 lb (1.45 kg)	3.2 lb (1.45 kg)
		Out of box, External	10.3 lb (4.65 kg)	10.3 lb (4.65 kg)	10.3 lb (4.65 kg)
		Out of box, Array Module	4.1 lb (1.85 kg)	N/A	4.1 lb (1.85 kg)
		Out of box, 1U Rack-mount	21.0 lb (9.52 kg)	N/A	21.0 lb (9.52 kg)
Out of box, 3U Rack-mount		30.5 lb (13.9 kg)	N/A	N/A	
Shipping, Internal		7.9 lb (3.6 kg)	7.9 lb (3.6 kg)	7.9 lb (3.6 kg)	
Shipping, External		17.6 lb (8.0 kg)	17.6 lb (8.0 kg)	17.6 lb (8.0 kg)	
Shipping, Array Module		8.8 lb (4.0 kg)	N/A	8.8 lb (4.0 kg)	
Shipping, 1U Rack-mount		32.9 lb (14.8 kg)	N/A	32.9 lb (14.8 kg)	
Shipping, 3U Rack-mount		52 lb (24 kg)	N/A	N/A	

Technical Specifications

Capacity	Native	100 GB	100 GB	200 GB
	Compressed (assumes 2:1 data compression)	200 GB	200 GB	400 GB
	Buffer Size	16 MB	64 MB	64 MB
Performance	Sustained transfer rate, native	7.5 MB/s	16 MB/s	24 MB/s
	Sustained transfer rate, compressed (assumes 2:1 data compression)	15 MB/s	32 MB/s	48 MB/s
	Burst transfer rate	80 MB/s (with Ultra2 SCSI wide)	160 MB/s (with Ultra3 SCSI wide)	160 MB/s (with Ultra3 SCSI wide)
	Data rate matching range	6-7.5 MB/s (native)	6.7-16 MB/s (native)	8-24 MB/s (native)
	Data access time (from BOT)	142s typical for a 100 GB tape (native)	64 s typical for a 100 GB tape (native)	64 s typical for a 200 GB tape (native)
	Average load time	25 s	17 s	17 s
	Average unload time	13 s	16 s	16 s
	Rewind time from EOT	284 s (100 GB tape)	121s (100 GB tape)	121 s (200 GB tape)
	Rewind tape speed	2.05 m/s	5.0 m/s	5.0 m/s
	Reliability	MTBF	250,000 hours at 100% duty cycle	250,000 hours at 100% duty cycle
Uncorrected Error Rate		1x10 ¹⁷ bits read	1x10 ¹⁷	1x10 ¹⁷
Media Compatibility		LTO Ultrium 1 with 4K Cartridge Memory	LTO Ultrium 1 with 4K Cartridge Memory	LTO Ultrium 1 with 4K Cartridge Memory; LTO Ultrium 2 with 4K Cartridge Memory
Tape Format	Recording method	8-channel linear serpentine	8-channel linear serpentine	8-channel linear serpentine
	Recording format	LTO Ultrium 1	LTO Ultrium 1	LTO Ultrium 2 LTO Ultrium 1 (for 100 GB tape)
	Data compression	LTO DC dual mode compression (an enhanced version of ALDC)	LTO DC dual mode compression (an enhanced version of ALDC)	LTO DC dual mode compression (an enhanced version of ALDC)
	Error detection/correction	Reed-Solomon	Reed-Solomon	Reed-Solomon
	Read channel technology	Peak Detect	Partial Response Maximum Likelihood (PRML)	Partial Response Maximum Likelihood (PRML)
	Data encoding method	RLL 1,7	RLL 1,7	RLL 0,13/11
	Interface	Interface type	Wide Ultra2 SCSI (LVDS)	Wide Ultra3 SCSI (LVDS)
SCSI connector		Internal: 68-pin LVDS External: 68-pin HD	Internal: 68-pin LVDS External: 68-pin HD	Internal: 68-pin LVDS External: 68-pin HD

Technical Specifications

LVDS Array module: 80-pin SCA (SCSI and power) Rack-mount: 68-pin HD LVDS	LVDS Array module: 80-pin SCA (SCSI and power) Rack-mount: 68-pin HD LVDS
---	---

Power Specifications	Power requirements, Internal (including rack-mount model)	+5V@3.0A (typical) +5V@3.5A (max) +12V@0.5A (typical) +12V@2.5A (max)	+5V@2.5A (typical) +5V@2.5A (max) +12V@0.7A (typical) +12V@2.1A (max)	+5V@2.5A (typical) +5V@2.5A (max) +12V@0.7A (typical) +12V@2.1A (max)
	Power requirements, External	100 to 240 VAC, 50-60 Hz, auto-ranging, 0.7A max	100 to 240 VAC, 50-60 Hz, auto-ranging, 0.7A max	100 to 240 VAC, 50-60 Hz, auto-ranging, 0.7A max
	Power requirements, Array Module	+5V@3.0A (typical) +5V@3.5A (max) +12V@0.5A (typical) +12V@2.5A (max)	N/A	+5V@2.5A (typical) +5V@2.5A (max) +12V@0.7A (typical) +12V@2.1A (max)
	Power consumption	10 Watts idle 19 Watts typical 38 Watts max	13 Watts idle 20 Watts typical 33 Watts max	13 Watts idle 20 Watts typical 33 Watts max

Environmental Specifications	Temperature range	Operating: 50° F to 95° F (10° C to 40° C) at a minimum of 6CFM airflow Storage: -40° F to 151° F (-40° C to 66° C)
	Non-condensing humidity range	Operating: 20 to 80% RH (non-condensing) Storage: 10 to 95% RH (non-condensing)

Standards Compliance CSA Certification to C22.2, No.60950 (cCSAus)
TÜV EN60950 (IEC 60950)
CE Declaration of Conformity
FCC 47 CFR Parts 15
NOM
VCCI
C-TICK
RRL
BSMI
GOSH
CB Certificate and Report (IEC 60950)

Front Panel LED Indicators

HP Ultrium half-height tape drives have four LED indicators on the front panel:

- Ready
- Drive
- Tape
- Clean

Please consult the HP StorageWorks Ultrium Tape Drive documentation for more information on how to use these LED indicators for ascertaining drive status and for help in troubleshooting your HP Ultrium tape drive.

Technical Specifications

© Copyright 2006 Hewlett-Packard Development Company, L.P.

The information contained herein is subject to change without notice.

Microsoft and Windows NT are US registered trademarks of Microsoft Corporation. Intel is a US registered trademark of Intel Corporation.

The only warranties for HP products and services are set forth in the express warranty statements accompanying such products and services. Nothing herein should be construed as constituting an additional warranty. HP shall not be liable for technical or editorial errors or omissions contained herein.

Free Manuals Download Website

<http://myh66.com>

<http://usermanuals.us>

<http://www.somanuals.com>

<http://www.4manuals.cc>

<http://www.manual-lib.com>

<http://www.404manual.com>

<http://www.luxmanual.com>

<http://aubethermostatmanual.com>

Golf course search by state

<http://golfingnear.com>

Email search by domain

<http://emailbydomain.com>

Auto manuals search

<http://auto.somanuals.com>

TV manuals search

<http://tv.somanuals.com>