

413A



HEWLETT-PACKARD COMPANY / OPERATING AND SERVICE MANUAL

413A *Prefix*
139
DC NULL VOLTMETER

413A

CERTIFICATION

THE HEWLETT-PACKARD COMPANY CERTIFIES THAT THIS INSTRUMENT WAS THOROUGHLY TESTED AND INSPECTED AND FOUND TO MEET ITS PUBLISHED SPECIFICATIONS WHEN IT WAS SHIPPED FROM THE FACTORY.

 FURTHER CERTIFIES THAT ITS CALIBRATION MEASUREMENTS ARE TRACEABLE TO THE NATIONAL BUREAU OF STANDARDS TO THE EXTENT ALLOWED BY THE BUREAU'S CALIBRATION FACILITY.



OPERATING AND SERVICE MANUAL

MODEL 413A/AR

SERIALS PREFIXED: 139

DC NULL VOLTMETER

Copyright HEWLETT-PACKARD COMPANY 1961
1501 PAGE MILL ROAD, PALO ALTO, CALIFORNIA, U.S.A.



01138-2

Printed: FEB 1962

TABLE OF CONTENTS

Section	Page	Section	Page
I GENERAL INFORMATION	1-1	V Cont'd	5-1
1-1. Introduction	1-1	5-7. Troubleshooting	5-1
1-4. Description	1-1	5-8. General	5-1
1-8. Three Conductor Power Cable	1-1	5-10. Amplifier-Power Supply	5-2
1-10. Calibration Accuracy	1-1	5-12. Chopper Assembly	5-2
II PREPARATION FOR USE	2-1	5-14. Modulator	5-2
2-1. Incoming Inspection	2-1	5-16. Demodulator	5-3
2-4. Reshipment	2-1	5-18. Repair and Replacement	5-4
2-6. Installation	2-1	5-19. General	5-4
2-8. 230-Volt Operation	2-1	5-21. Modulator Replacement	5-4
2-10. Environmental Limits	2-1	5-23. Demodulator Replacement	5-4
III OPERATING INSTRUCTIONS	3-1	5-25. Range (Volts) Switch Replacement	5-4
3-1. Introduction	3-1	5-27. Tube Replacement	5-4
3-5. Controls	3-1	5-29. Adjustments	5-6
3-7. Operating Instructions	3-1	5-31. Mechanical Zero Adjustment	5-6
IV PRINCIPLES OF OPERATION	4-1	5-33. Hum Balance	5-6
4-1. General	4-1	5-34. Bias Adjust	5-6
4-3. DC Input Circuits	4-1	5-35. Amplifier Gain Calibration and Meter Calibration	5-6
4-5. AC Circuits	4-1	5-36. Preliminary	5-6
4-9. DC Output Circuits	4-2	5-38. Gain Calibration	5-7
4-11. Power Supply	4-2	5-40. Performance Verification	5-7
V MAINTENANCE	5-1	5-42. Voltmeter	5-7
5-1. Introduction	5-1	5-43. AC Rejection	5-8
5-3. Test Instruments Required	5-1	5-44. Amplifier Output	5-8
5-5. Cabinet Removal	5-1	VI REPLACEABLE PARTS	6-1
		6-1. Introduction	6-1
		6-5. Ordering Information	6-1

LIST OF ILLUSTRATIONS

Number	Title	Page	Number	Title	Page
1-1.	Model 413A DC Null Voltmeter	1-0	5-4.	Cabinet/Rack Demodulator Differences	5-4
2-1.	230-Volt Operation	2-0	5-5.	S101 Range (Volts) Switch Detail	5-5
2-2.	Rack Mount Unit	2-0	5-6.	Hum Balance Test Setup	5-6
3-1.	Operating Controls	3-0	5-7.	Preliminary Test Setup	5-6
4-1.	Model 413A Block Diagram	4-0	5-8.	Amplifier Calibration Test Setup	5-7
4-2.	Modulator/Demodulator Operation (Phase One)	4-1	5-9.	Performance Test (Voltmeter) Setup	5-7
4-3.	Modulator/Demodulator Operation (Phase Two)	4-1	5-10.	Performance Test (Amplifier) Setup	5-8
5-1.	A101, Chopper Assembly	5-2	5-11.	Servicing Etched Circuit Boards	5-9
5-2.	Approximate Chopper Waveform	5-2	5-12.	Model 413A Right Side View	5-10
5-3.	Exploded View, Showing Disassembly for Modulator Replacement	5-3	5-13.	Model 413A Left Side View	5-11
			5-14.	Model 413A Bottom View	5-12
			5-15.	Model 413A DC Null Voltmeter	5-13
			5-16.	Power Supply	5-14

LIST OF TABLES

Number	Title	Page
5-1.	Equipment Required	5-1
5-2.	Tube Replacement	5-6
6-1.	Reference Designation Index	6-1
6-2.	Replaceable Parts	6-7

TABLE OF SPECIFICATIONS

VOLTMETER

- Ranges: Positive and negative voltages from 1 mv to 1000 volts end scale in 13 zero-center ranges
- Accuracy: $\pm 2\%$ of end scale
- Limits of Zero Control: Approximately \pm end scale on any range
- Input Resistance: 10 megohms on 1, 3, and 10 millivolt ranges
30 megohms on 30 mv range
100 megohms on 100 mv range
200 megohms on 300 mv range and above
- AC Rejection: A voltage at power line or twice power line frequency 40 db greater than end scale affects reading less than 1%. Peak voltage must not exceed 1500 volts.

AMPLIFIER

- Gain: 0.001 to 1000 in 13 steps
- Gain Accuracy: $\pm 1-1/2\%$
- Linearity: $\pm 0.2\%$
- Noise: Less than 0.1% (rms) of end scale on any range
- Output: 1 volt for end scale deflection, same polarity as input signal. End scale corresponds to 1.0 on upper scale. Maximum load current is 1 milliampere.
- Output Impedance: Less than 2 ohms at dc
- AC Rejection: Approximately 3 db at 1 cps, 80 db at 50 and 60 cps

GENERAL

- Input Terminals: Binding post
- Input Isolation: Greater than 100 megohms shunted by 0.1 μ f to case (power line ground)
- Common Signal Rejection: May be operated with up to 500 volts dc or 130 volts ac above ground
- Power: 115 or 230 volts $\pm 10\%$, 50 to 60 cps, approximately 35 watts
- Dimensions: Cabinet Mount: 11-1/2 inches high, 7-1/2 inches wide, 10 inches deep
Rack Mount:

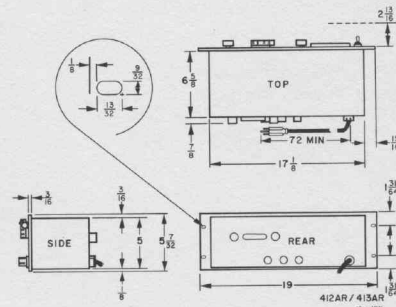

Weight: Cabinet Mount: Net 12 lbs, shipping 17 lbs



Figure 1-1. Model 413A DC Null Voltmeter

SECTION I

GENERAL INFORMATION

1-1. INTRODUCTION.

1-2. SCOPE. This manual supplies operation and maintenance information for the \odot Model 413A DC Null Voltmeter. A performance check that may be used for verifying specifications during incoming inspection is given in paragraph 5-40.

1-3. INSTRUMENT IDENTIFICATION. Hewlett-Packard Company uses a two-section eight-digit serial number (e.g. 000-00000). If the first three digits of the serial number on your instrument do not agree with those on the title page of this manual, yellow change sheets have been supplied with the manual which define differences between your instrument and the model described in this manual. If these change sheets are missing, your Hewlett-Packard sales representative can supply you with this information.

1-4. DESCRIPTION.

1-5. GENERAL. The Model 413A DC Null Voltmeter is a zero-center dc voltmeter with end scale ranges from 1 mv to 1000 volts in a 1-3-10 sequence. Input impedance varies from 10 megohms to 200 megohms depending on the setting of the RANGE (VOLTS) switch. The input terminals are isolated from the cabinet and ground permitting operation from references up to 500 volts dc or 130 volts ac from ground potential.

1-6. INDICATORS. In addition to the conventional meter, which has both a normal ($\pm 10\%$ of full scale) and expanded (\pm full scale) range of zero adjustment, the Model 413A has amplifier output connectors which provide an output voltage proportional to meter deflection. This feature makes it possible to use the Model 413A as a dc amplifier for use with thermocouples, etc., or to use it in conjunction with a recorder to obtain permanent records without the need for constant monitoring.

1-7. USES. The Model 413A may be used for any application that calls for a dc null voltmeter. High input impedance of the instrument makes it especially valuable for resistance bridge measurements. The high voltage gain and the exceedingly low drift and noise make the Model 413A an ideal instrument for many control applications, particularly where the system must be left unattended for long periods of time.

1-8. THREE-CONDUCTOR POWER CABLE.

1-9. For the protection of operating personnel, the National Electrical Manufacturers' Association (NEMA), recommends that the instrument panel and cabinet be grounded. All Hewlett-Packard instruments are equipped with a three-conductor power cable which, when plugged into an appropriate receptacle, grounds the instrument. The offset pin on the power cable three-prong connector is the ground pin. To preserve the protection feature when operating the instrument from a two-contact outlet, use a three-prong to two-prong adapter and connect the green pigtail on the adapter to ground.

1-10. CALIBRATION ACCURACY.

1-11. The Hewlett-Packard Company certifies that this instrument was thoroughly tested and inspected, and found to meet its published specifications when it was shipped from the factory.

1-12. It further certifies that its calibration measurements are traceable to the National Bureau of Standards to the extent allowed by the Bureau's certification facility.

1-13. Adjustments should not be attempted unless malfunction has been definitely established by following the performance verification check in paragraph 5-40 of this manual.

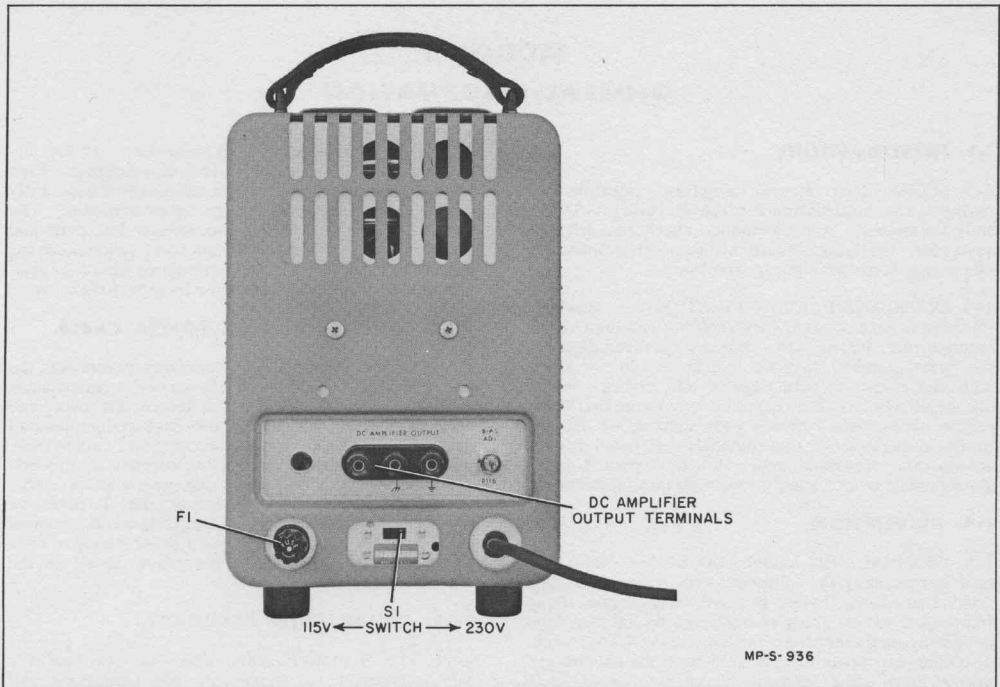

Figure 2-1. 230-Volt Operation



Figure 2-2. Rack Mount Unit

SECTION II

PREPARATION FOR USE

2-1. INCOMING INSPECTION.

2-2. MECHANICAL INSPECTION. Care is taken in packing Hewlett-Packard instruments to assure undamaged delivery. Despite these precautions, however, damage in shipment will sometimes occur. Upon receipt of your 413A, check the contents against the packing list and inspect the instrument for any obvious damage received in transit. If damage is evident, file claim with the carrier. To facilitate reshipment, keep the packing material until an operational check has been made (see paragraph 2-3). Refer to the warranty sheet in this manual for additional information.

2-3. OPERATIONAL CHECK. Paragraph 5-40 includes an in-cabinet check for verifying proper instrument operation as given in published specifications. If the Model 413A is to be operated from a 230-volt source refer to paragraph 2-8.

2-4. RESHIPMENT.

2-5. If, after incoming inspection, damage is evident, repack the instrument in its original shipping container taking care to replace all pads in their original positions. If the packing material was discarded, contact your nearest Hewlett-Packard sales office for information and/or packaging material. If this is not possible, the Model 413A should be packed in a strong exterior container and surrounded by 3 to 4 inches of cushioning material designed specifically for package cushioning.

2-6. INSTALLATION.

2-7. No special installation procedures are required for the Model 413A cabinet model. The Model 413AR rack mount (figure 2-2) mounts in a standard 19-inch rack. Amplifier output connectors are provided on both front and rear of the Model 413AR rack unit.

2-8. 230-VOLT OPERATION.

2-9. If 230-volt operation is desired, a screwdriver-operated switch (see figure 2-1) is provided on the rear of the instrument. A fuse of different rating should be used. See Table of Replaceable Parts in section VI.

2-10. ENVIRONMENTAL LIMITS.

2-11. The Model 413A is designed to operate within the following environmental conditions.

- a. Storage temperature: $+167^{\circ}\text{F}$ (75°C) to -40°F (-40°C).
- b. Operating temperature: 130°F (55°C) to 32°F (0°C).
- c. Radio interference: meets the requirements of MIL-I-169104.
- d. Altitude: 0 to 25,000 feet.

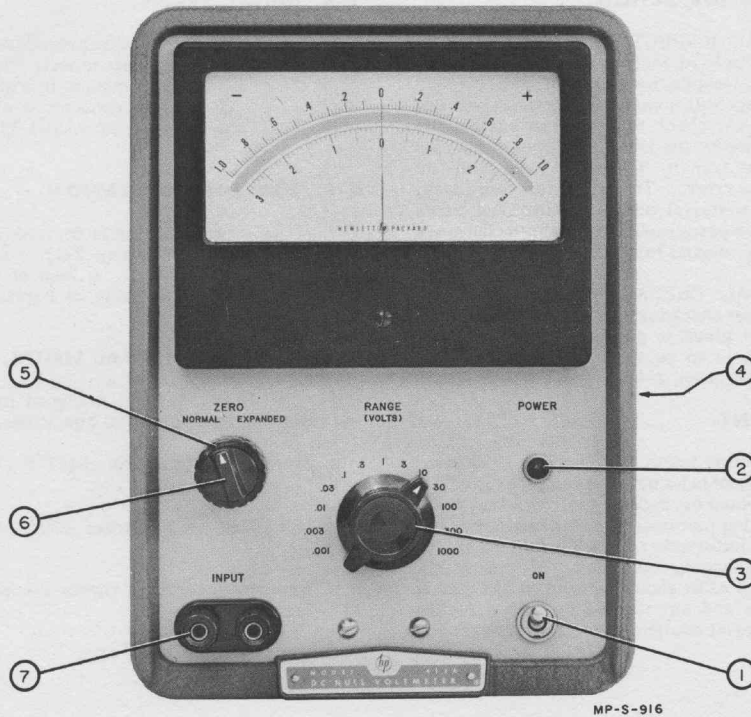

1. Power switch. Turns instrument ON.
2. Pilot Light. Lights when instrument is ON.
3. RANGE (VOLTS) switch. For selecting voltage range desired.
4. Amplifier Output terminals (rear of instrument, not shown). Provides an output voltage proportional to meter deflection.
5. ZERO control. Used to adjust electrical zero setting of meter.
6. NORMAL-EXPANDED switch. Provides a choice of EXPANDED (\pm end scale) or a NORMAL ($\pm 10\%$ end scale) range of zero adjustment.
7. INPUT connectors. Apply voltage to be measured here (413A input is fully floating).

Figure 3-1. Operating Controls

SECTION III

OPERATING INSTRUCTIONS

3-1. INTRODUCTION.

3-2. GENERAL. This section contains information on the function and use of all controls on the Model 413A DC Null Voltmeter. If more theoretical information is desired, refer to section IV, Principles of Operation.

3-3. LOW-LEVEL ELECTRICAL PHENOMENA.

Stray low-level electrical phenomena are present, in one form or another, in nearly all electrical circuits. The 413A does not distinguish between stray and signal voltages; it measures net voltage. Thus, when using the lower voltage ranges, consider the possibility of low-level electrical phenomena. Thermocouples (thermoelectric effect), flexing of coaxial cables (triboelectric effect), apparent residual charges on capacitors (dielectric absorption), battery action of two terminals mounted on an imperfect insulator (galvanic action) all can produce voltages within the range of the 413A.

3-4. Whenever possible, use copper wire leads and maintain the points of connection at the same temperature, preferably ambient temperature. With the leads so connected, any voltage indicated by the 413A is developed within the circuit under test.

3-5. CONTROLS.

3-6. Figure 3-1 shows all operating controls and gives a short description of their use. Numbers in figure 3-1 are given to relate the text in figure 3-1 to the photograph, and do not necessarily indicate operational procedure (see paragraph 3-7). More detailed information related to these controls is listed below:

a. RANGE (VOLTS) switch. The RANGE (VOLTS) switch adjusts the input circuit so that any voltage between .001 and 1000 volts may produce end scale deflection on the meter. The last position of the RANGE (VOLTS) switch is used to adjust the cathode follower bias (see paragraph 5-34).

b. INPUT terminals. The voltage to be measured should be connected to these terminals. Polarity is not important insofar as 413A operation is concerned. However, to prevent ac loading of the circuit under test, the low impedance line should be connected to the right-hand terminal, since this terminal has the higher capacitance to ground.

c. ZERO adjustment. The ZERO adjustment may be used to adjust the electrical zero of the instrument to the desired value. Meter calibration is correct only when the meter needle is set to zero (amplifier output voltage is always proportional to meter reading).

d. NORMAL-EXPANDED switch. The NORMAL-EXPANDED switch provides two ranges of zero adjustment. NORMAL position is used when the meter needle has to be set critically within $\pm 10\%$ of end scale from zero. EXPANDED is used when it is desired to set a reference near the scale ends. Meter sensitivity is unaffected by the setting of this control.

e. Amplifier Output terminals. The amplifier output terminals, (figure 2-1) located on the rear of the 413A cabinet mount, and on both the front and rear of the 413AR rack mounted instrument, provide an output voltage proportional to meter deflection. End scale meter deflection produces 1 volt output with the same polarity as the input signal.

3-7. OPERATING INSTRUCTIONS.

3-8. The following is a step-by-step procedure for operating the 413A. When operating the 413A, be sure that the ambient temperature is within the limits specified in paragraph 2-10. Proceed as follows:

CAUTION

Do not overload this instrument. The amplifier input is not protected from extreme overload. Momentary overloads ten times full scale will not damage the instrument.

- a. Turn the power switch ON and allow 5 minutes for the instrument to stabilize.
- b. Set NORMAL-EXPANDED switch to the position desired.
- c. Turn the RANGE (VOLTS) switch to the required level.
- d. Adjust the ZERO control to the desired setting. (Zero offset, if any, remains constant regardless of the range setting.)
- e. Connect the voltage to be measured to the input connectors.

3-9. OPERATION WITH A RECORDER. To obtain permanent records of 413A readings, connect a recorder to the dc amplifier output connector, and operate the 413A as directed in paragraph 3-7. The output of the 413A amplifier is 1-volt end scale; if necessary, externally attenuate the 413A output to match it with recorder sensitivity. Maximum rated load current from the 413A is 1 ma. A load resistance of less than 1000 ohms may cause the load current to exceed 1 ma and thus cause errors in meter indication and amplifier gain.

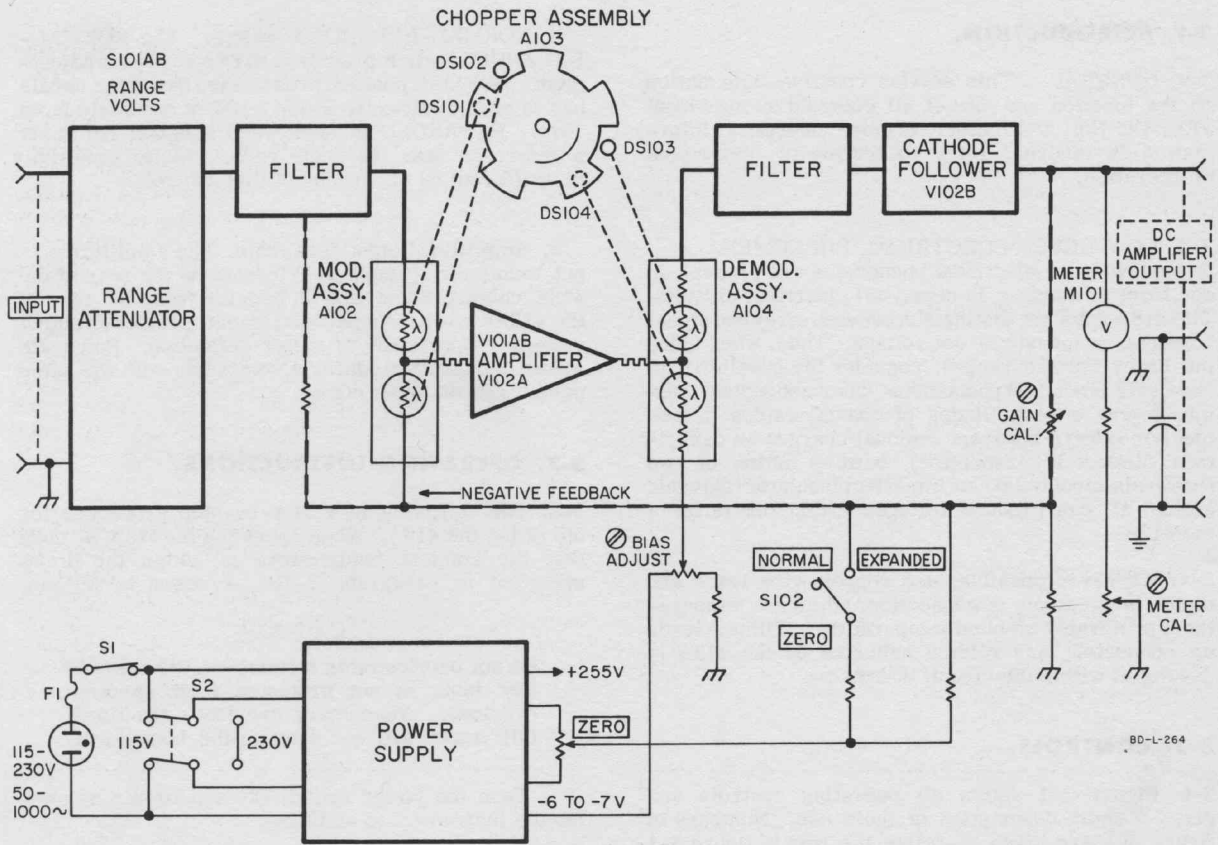

Figure 4-1. Model 413A Block Diagram

SECTION IV PRINCIPLES OF OPERATION

4-1. GENERAL.

4-2. The 413A is a dc voltmeter which accomplishes amplification of the dc input voltage without the usual problems of dc drift etc., by first changing the dc to ac, amplifying it and then changing it back to dc for application to the meter circuit and amplifier output connector. Refer to figure 4-1 (block diagram) and to the schematic (figures 5-15 and 5-16) for the following discussion.

4-3. DC INPUT CIRCUITS.

4-4. The input voltage is first fed to range attenuator S101AB where it is attenuated according to the setting of the RANGE (VOLTS) control. The voltage is then fed through a low pass filter made up of R101-103 and C101-103 to a photoconductor modulator, A102. The filter attenuates any ac components present in the input voltage.

4-5. AC CIRCUITS.

4-6. MODULATOR. A synchronous motor, B101, drives a light interrupter which controls the resistance of the photoconductors (photosensitive resistors) in A102 modulator and A104 demodulator units. In

order to simplify the following circuit explanation, the modulator will be discussed alone. However, this discussion applies to demodulator operation as well.

4-7. In figure 4-2, B101 has turned the light interrupter, and allowed the light source (DS102) to shine on photoconductor V1, lowering its resistance to a few thousand ohms. Since photoconductor V2 maintains its "dark" resistance of many megohms, the voltage to the amplifier will be about the same as the dc voltage applied to the modulator. In figure 4-3, however, B101 has turned the shutter assembly sufficiently to turn off the light source to V1 and turn on the light (DS101) to V2. Now the resistance of V1 will return to its high "dark" resistance, whereas the resistance of V2 will be very low. The voltage to the amplifier will now be some very low voltage determined by the ratio of the photoconductor resistances. This action continues resulting in a square-wave signal of 5/6 line frequency.

4-8. AC AMPLIFIER. The ac amplifier, consisting of V101AB and V102A, is a conventional circuit which amplifies the modulator output about 500,000 times. The output from V102A is fed to demodulator unit A104 which is synchronized with the modulator. The operation of the demodulator is similar to the modulator but its action is essentially the reverse; e.g. to change the square wave output from the amplifier back to dc.

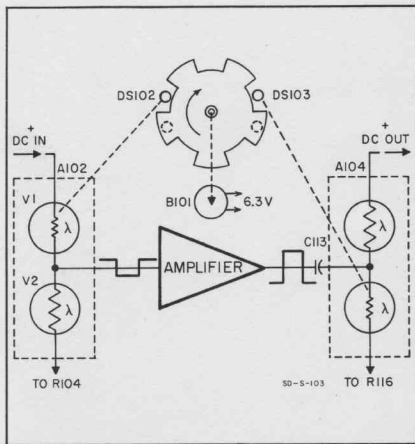

Figure 4-2. Modulator/Demodulator Operation (Phase One)

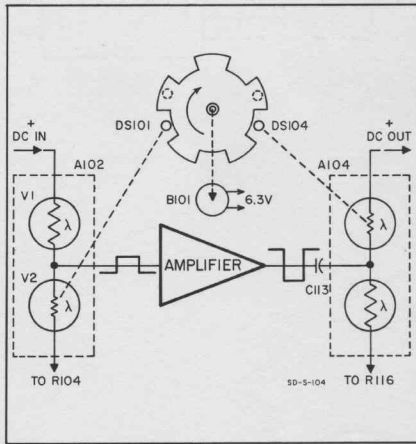

Figure 4-3. Modulator/Demodulator Operation (Phase Two)

4-9. DC OUTPUT CIRCUITS.

4-10. The output from the demodulator is filtered by C114-116 and R114-118 and fed to cathode follower V102B. Cathode follower bias is set by adjusting R116 Bias Adjust. The output of V102B is used for the following purposes:

- a. For meter deflection. R123 is used to adjust the meter current to the correct value.
- b. To provide a dc output voltage proportional to meter deflection. This voltage is available at the dc amplifier output terminals.
- c. For feedback to the modulator assembly A102, and the filter network. The negative feedback, adjusted with R119 Gain Cal., stabilizes the dc gain of the

modulator-amplifier-demodulator system to a value of 1111, thereby providing an output of 1 volt for an input of 0.9 millivolts.

4-11. POWER SUPPLY.

4-12. The 413A power supply is a conventional full-wave rectifier with resistors R1, R2, and zener diode CR1 in the power transformer center tap to develop the -6 to -7 volts for the cathode follower bias. Resistor R8, ZERO, adjusts meter zero by changing the dc bias of the modulator-amplifier-demodulator network. Switch S2 changes T1 primary circuit for 230-volt operation. A fuse of different rating must be used in case of 230-volt operation (see Table of Replaceable Parts).

SECTION V MAINTENANCE

5-1. INTRODUCTION.

5-2. This section contains test and maintenance information for the Model 413A DC Null Voltmeter. A performance check is included (paragraph 5-40) that may be used to verify operation within published specifications. This check should be made with the instrument in its cabinet, and is a good test as part of routine maintenance or as a part of your incoming inspection.

5-3. TEST INSTRUMENTS REQUIRED.

5-4. Table 5-1 lists the test equipment that is required to complete the maintenance instructions in this section. Instruments other than those recommended may be used, provided their performance meets the basic requirements given in table 5-1.

5-5. CABINET REMOVAL.

5-6. To remove the 413A cabinet, proceed as follows:

- a. Unplug power cord from the power source.

- b. Remove the two retaining screws on the rear of the instrument (three screws for the rack mounted 413AR).

- c. Slide the instrument chassis forward out of the cabinet. Bezel ring remains attached to the front panel.

CAUTION

Do not lubricate the RANGE (VOLTS) switch or touch the switch wafers with the fingers in the following procedures. Wear a pair of light cotton gloves when handling the switch, since skin oils and acids can contaminate the switch wafers and degrade instrument performance.

5-7. TROUBLESHOOTING.

5-8. GENERAL.

5-9. The following paragraph gives information to aid in the localization of troubles in the 413A. In most cases, a trouble may be localized to a section from

Table 5-1. Equipment Required

Instrument Type	Minimum Required Specifications	Use	Recommended Instruments
Voltmeter Calibration Generator	Output Voltage Range: .001 to 300 volts Signal Frequency: dc Accuracy: $\pm 0.25\%$	413A Amplifier Calibration	Ⓢ Model 738AR Voltmeter Calibrator
Low Frequency Oscilloscope	Sensitivity: 0.01 volt/cm minimum Frequency Response: flat down to at least 10 cps	For 10 cps hum measurements and modulator check	Ⓢ Model 120AR Oscilloscope
Electronic Voltmeter	Sensitivity: 0.05 volt full scale Input Resistance: 10 megohms or higher	Troubleshooting and amplifier gain calibration	Ⓢ Model 412A or 413A Vacuum Tube Voltmeters
Variable Power Transformer	Variation: from at least 102 to 128 volts Current Capabilities: at least 1 ampere Monitor Voltmeter: accurate to at least ± 1 volt	Power supply check	General Radio W10MT3A Metered Variac® Auto-transformer
Ohmmeter	Accuracy: $\pm 5\%$ Ranges: to at least 10 megohms full scale	Troubleshooting	Ⓢ Model 410B or 412A Vacuum Tube Voltmeters
Voltage Source	Voltage: between 1 and 2 volts	Amplifier Gain Calibration	Burgess HG3 Burgess No. 2, Size D flashlight cell or equivalent

front panel indications. A good method is to follow the performance verification procedure (paragraph 5-40) until the trouble manifests itself as a reading that is out of the listed specifications. For example, if the instrument operates properly on all voltage ranges but .003, only R82, R84 or associated switch contacts and wiring can be faulty. A bad reading on all ranges indicates trouble in the modulator-amplifier-demodulator system, or in the power supply.

Note

The 413A is a sensitive instrument. If it gives unexpected readings on its lowest voltage ranges, it may be measuring thermoelectric voltages, etc., in addition to the expected voltage (see paragraph 3-3).

5-10. AMPLIFIER-POWER SUPPLY.

5-11. Amplifier and power supply operation is best checked by voltage readings and tube substitution. If tube substitution does not correct the difficulty, return the original tube to the instrument. If tubes are changed, refer to table 5-2 for any necessary adjustments. Voltages are indicated at various points on the schematic diagrams (figures 5-15 and 5-16); these are typical voltages and may vary somewhat from instrument to instrument.

5-12. CHOPPER ASSEMBLY.

5-13. Before the modulator or demodulator can be checked, it must be ascertained that the chopper assembly, A103, is functioning properly. Refer to figure 5-1 for location of parts in the following steps. Proceed as follows:

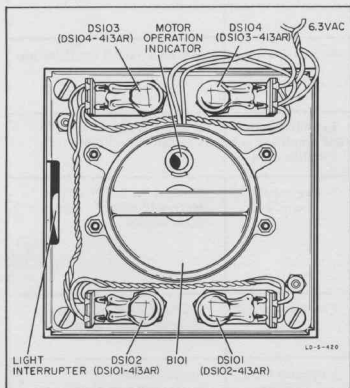

Figure 5-1. A103, Chopper Assembly

5-2

- a. Remove cabinet (paragraph 5-5).
- b. Check all four lamps (DS101-104) to make sure they glow when power is applied.
- c. Check the light interrupter in the cut away portion of the chopper assembly to see if the chopper blades are rotating. A soldering aid may be inserted into the slot for a moment if necessary to check operation.
- d. If the chopper blades are not turning, look at the motor operation indicator in the back of motor B101. If B101 is operating, the chopper blade is loose on its shaft. If not, check the 6.3 volt circuit to the motor.

5-14. MODULATOR.

5-15. To check modulator operation, proceed as follows:

- a. Unplug the 413A from the power source, and remove the cabinet (paragraph 5-5).
- b. Remove V101 and reconnect the 413A to the power source.
- c. Connect a clip lead from the 413A input terminals to the center arm of R116, Bias Adjust Potentiometer.
- d. Set RANGE (VOLTS) to .001.
- e. Set oscilloscope input to DC.
- f. Connect one lead of an 8.2-megohm resistor to oscilloscope signal connector (or probe). Using a jumper wire, connect the other resistor lead to the junction of R85 and S101D (point A in figure 5-5). Connect oscilloscope common lead to 413A common connector.
- g. Observe amplitude of the dc voltage at point A.
- h. Move oscilloscope probe (with resistor) to point B in figure 5-3.
- i. Waveform should be similar to that shown in figure 5-2, and should have a peak-to-peak amplitude approximately equal to the deflection found in step g. Signal frequency should be 5/6 line frequency.

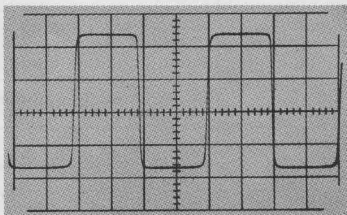

Figure 5-2. Approximate Chopper Waveform

LD-5-451

01138-1

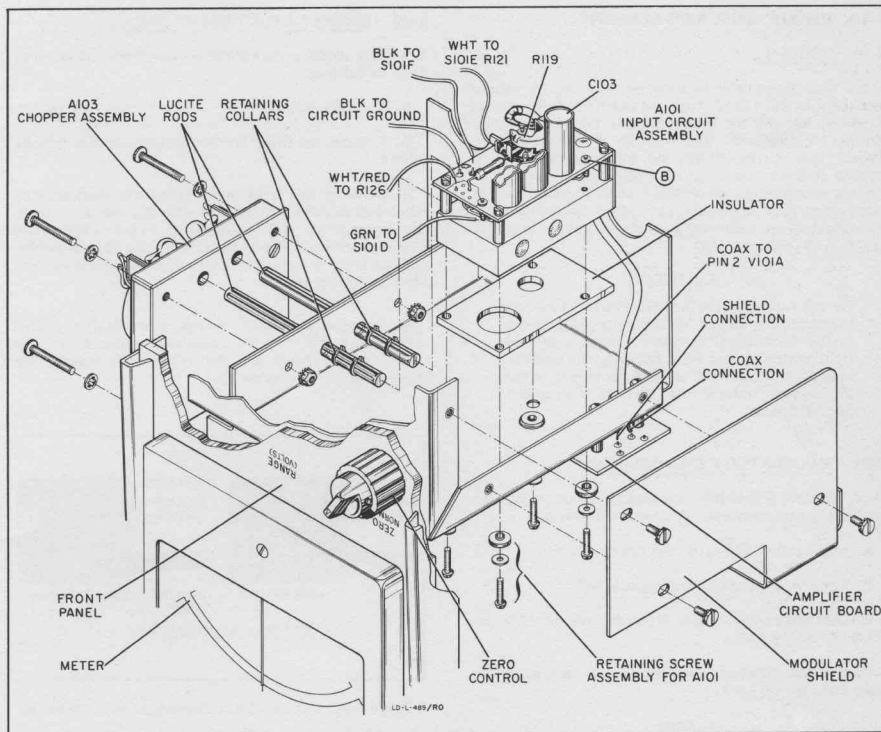

Figure 5-3. Exploded View, Showing Disassembly for Modulator Replacement

5-16. DEMODULATOR.

5-17. The demodulator assembly (A104) is located behind the meter between the main chassis and the power transformer (see figures 5-4 and 5-13). Proceed as follows:

- Unplug the 413A from the power source and remove the cabinet (see paragraph 5-5).
- Remove V102.
- Remove DS103 (figure 5-1) from chopper assembly A103.
- Connect a 1 μ f capacitor across the input terminals of the ohmmeter.
- Connect the ohmmeter common lead to the demodulator terminal which has the pink-orange lead connected to it.
- Connect the other ohmmeter lead to the terminal which has the white-orange lead connected to it.

g. Plug the 413A into the power source and turn it ON.

h. Note resistance indicated on the ohmmeter. Typical resistance is between 1 and 2 megohms.

i. Turn the 413A off and unplug it from the power source.

j. Replace DS101 and remove DS102.

k. Connect the ohmmeter common lead to the demodulator terminal which has the brown-orange lead connected to it.

m. Connect the other lead from the ohmmeter to the terminal which has the white-orange lead connected to it.

n. Plug the 413A into the power source, turn it ON and note the resistance indicated on the ohmmeter. Typical resistance is between 1 and 2 megohms.

p. Turn the 413A off and replace DS102 and V102.

5-18. REPAIR AND REPLACEMENT.

5-19. GENERAL.

5-20. This paragraph is intended to simplify repair problems in the 413A. Tube replacement information is given, as well as repair procedures for the modulator, demodulator and RANGE (VOLTS) switch. Repair procedures should be followed carefully to assure correct operation of replacement parts. Replacing components on etched circuit boards requires extra care (see figure 5-11). After component replacement in the following paragraphs, refer to paragraph 5-29 (adjustments).

CAUTION

Do not lubricate the RANGE (VOLTS) switch or touch the switch wafers with the fingers in the following procedures. Wear a pair of light cotton gloves when handling the switch, since skin oils and acids can contaminate the switch wafers and degrade instrument performance.

5-21. MODULATOR REPLACEMENT.

5-22. Figure 5-3 shows necessary disassembly for modulator replacement. Proceed as follows:

- Unplug the 413A from the power source.
- Remove the cabinet (paragraph 5-5).
- Disconnect all wires from the top of A101 as shown in figure 5-3.
- Remove chopper assembly, A103, and slide the light rods out of A101.

Note

In the 413AR rack mount unit, it is not necessary to remove the chopper assembly. Perform step e and slide A101 away from the light rods.

- Remove the four screws holding the input circuit assembly (A101) to the main chassis. When replacing this assembly, be sure to reseat the insulated washers (figure 5-3) in their proper positions.
- Disconnect the green lead at A101.
- Carefully unsolder the shielded cable (figure 5-3) from the amplifier circuit board (pin 2 and 3 of V101A). (A length of cable is normally supplied with the input circuit assembly. However, if it is more convenient, and the cable is known to be good, it may be disconnected at the input assembly circuit board.) In any case, avoid undue heat that might damage the inner conductor insulating material in the coax.
- Reverse the above procedure to install the replacement assembly.

5-4

5-23. DEMODULATOR REPLACEMENT.

5-24. To replace demodulator assembly, A104, proceed as follows:

- Turn the 413A off.
- Remove the three leads connected to the demodulator.
- Remove the two nuts from the demodulator mounting screws and remove the demodulator from the instrument. If it is necessary to get at the screw heads to remove the nuts, remove the four mounting screws from the chopper assembly and let the assembly hang by its leads.
- Reverse the above procedure to install replacement assembly. Wire connection differs for the 413A cabinet mount and the 413AR rack mount. See figure 5-4 for wiring detail.

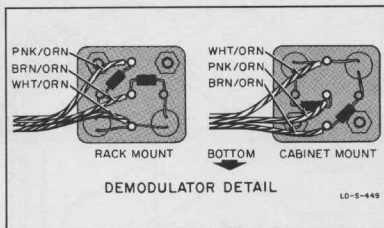

Figure 5-4. Cabinet/Rack Demodulator Differences

5-25. RANGE (VOLTS) SWITCH REPLACEMENT.

5-26. Figure 5-5 shows the location of all parts and wire destinations for the replacement of the RANGE (VOLTS) switch. The Model 413A should be checked for correct calibration after replacing this switch.

CAUTION

Make solder connections as quickly as possible when replacing components on the RANGE (VOLTS) switch. AVOID EXCESSIVE HEAT. Excessive heat will damage the switch wafers. Observe handling precautions described in paragraph 5-20.

5-27. TUBE REPLACEMENT.

5-28. If tubes are suspected of being defective, check them by substitution and replace only those which are defective. Table 5-2 gives any adjustments necessary after tube replacement.

01138-2

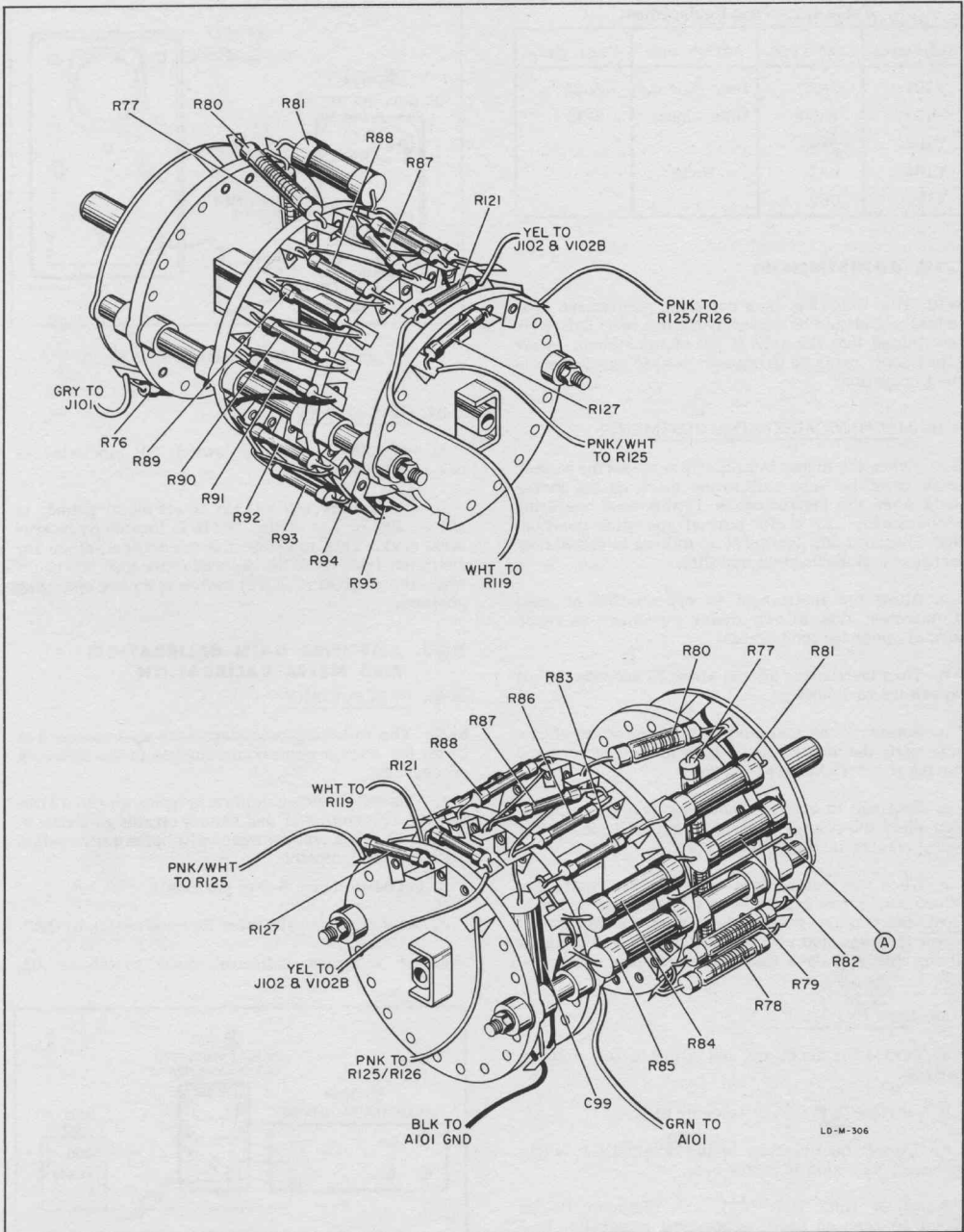

Figure 5-5. S101 Range (Volts) Switch Detail

Table 5-2. Tube Replacement

Ref. Desig.	Tube Type	Adjustment	Para. Ref.
V101	12AX7	Hum Balance	5-33
V102	6AU8	Bias Adjust	5-35
V103	6X4		
V104	0A2	None	
V105	0B2		

5-29. ADJUSTMENTS.

5-30. The following is a complete adjustment procedure and should be made only if it has been definitely determined that the 413A is out of adjustment. After adjustment, refer to paragraph 5-40 to check instrument operation.

5-31. MECHANICAL ZERO ADJUSTMENT.

5-32. When the meter is properly zero-set the pointer rests over the zero calibration mark on the meter scale when the instrument is 1) at normal operating temperature, 2) in its normal operating position, and 3) turned off. Zero-set as follows to obtain best accuracy and mechanical stability:

- Allow the instrument to operate for at least 20 minutes; this allows meter movement to reach normal operating temperature.
- Turn instrument off and allow 30 seconds for all capacitors to discharge.
- Rotate mechanical zero-adjustment screw clockwise until the meter pointer is to the left of zero and moving to the right toward zero.
- Continue to rotate adjustment screw clockwise; stop when the pointer is right on zero. If the pointer overshoots zero, repeat steps c and d.
- When the pointer is exactly on zero rotate the adjustment screw approximately 15 degrees counter-clockwise. This is enough to free the adjustment screw from the meter suspension. If the pointer moves during this step, you must repeat steps c through e.

5-33. HUM BALANCE.

- Turn instrument on and allow a few minutes warmup.
- Set RANGE (VOLTS) selector to 1.
- Connect oscilloscope to the dc amplifier output connector as shown in figure 5-6.
- Adjust Hum Bal. (R3), for minimum 10-cps signal as seen on oscilloscope. (If power-line frequency is 50 cps, adjust for minimum 8-1/3 cps signal.) See figure 5-13 for location of R3.

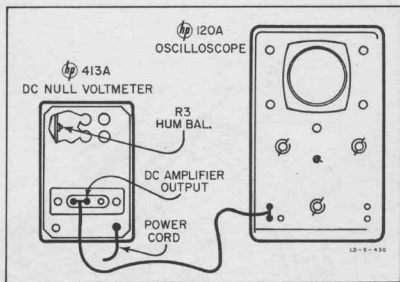

Figure 5-6. Hum Balance Test Setup

5-34. BIAS ADJUST.

- Set RANGE (VOLTS) switch full clockwise -- one step beyond 1000.
- Adjust Bias Adj. (R116), to set meter pointer to zero $\pm 20\%$ of end scale. R116 is located on instrument rear. This adjustment is not critical, since any deviation from zero is reduced more than 300 times when the RANGE (VOLTS) switch is on any operating position.

5-35. AMPLIFIER GAIN CALIBRATION AND METER CALIBRATION.

5-36. PRELIMINARY.

5-37. The following procedure sets up a standard of 1 volt for voltage comparison for use in the following procedures:

- Connect a voltage calibration generator to a 313A or 412A test voltmeter and battery circuit as shown in figure 5-7. This test voltmeter will hereafter be called the accuracy indicator.
- Set S1 in figure 5-7 to position 1.
- Set voltmeter calibrator function switch to OFF.
- Set accuracy indicator range switch to .03.

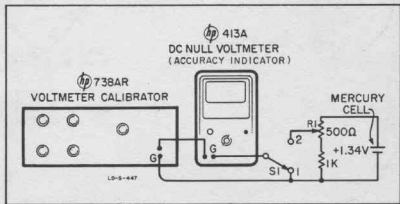

Figure 5-7. Preliminary Test Setup

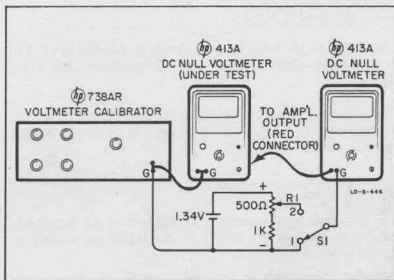

Figure 5-8. Amplifier Calibration Test Setup

e. If the accuracy indicator has no zero control, observe the meter reading. This reading will be used as the "zero error point".

f. If the accuracy indicator has a zero control (as in figures 5-7 and 5-8), adjust the ZERO control for zero on the meter. At the same time set S1 to position 2 and voltmeter calibrator function switch to DC+.

g. Adjust R1 for the same reading observed in steps e or f (zero error point). This accurately establishes one volt at the center arm of R1.

h. Each cardinal (numbered) point on the accuracy indicator scale is now 1%, giving a range of +3% for the accuracy indicator.

5-38. GAIN CALIBRATION.

5-39. The following procedure uses the standardized test setup from paragraph 5-37. Proceed as follows:

a. Connect the accuracy indicator and the voltmeter calibrator to the 413A under test as shown in figure 5-8.

Note

The rest of this procedure assumes that a DC Null Voltmeter such as the Model 413A is being used as the accuracy indicator.

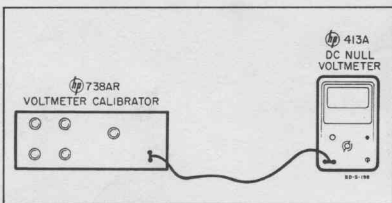

Figure 5-9. Performance Test (Voltmeter) Setup

01138-2

- b. Set S1 in figure 5-8 to position 1.
- c. Set the voltmeter calibrator function switch to OFF and the range switches to provide a +1 volt output.
- d. Set 413A RANGE (VOLTS) switch to 1.
- e. Adjust 413A ZERO control to read zero on the accuracy indicator.
- f. Set S1 in figure 5-8 to position 2 and set voltmeter calibrator function switch to DC+.
- g. Adjust R119, Gain Cal., (on the 413A under test) for a reading of zero on the accuracy indicator.
- h. Adjust R123, Meter Cal., for an end-scale reading of 1 volt on the 413A.

i. Repeat steps 7, 8, and 9 using positive test voltages ranging from 0.001 volts through 300 volts from the voltmeter calibrator. Set the 413A RANGE (VOLTS) switch to the appropriate range for each voltage. Record the error readings of all ranges, taking into account the algebraic sign of error observed.

j. Reverse the battery connection in the test setup in figure 5-8, and repeat step i using negative test voltages. If necessary, standardize the accuracy indicator for negative voltages. (Follow paragraph 5-37, steps a through i with battery connections reversed.)

k. Study the error readings and determine a new setting for R119, Gain Cal., that will result in the best overall error figures for the entire voltage range.

m. Adjust R119 for this new value on some convenient range.

n. The final setting must reduce error on any scale to less than $\pm 1.5\%$ on the accuracy indicator and $\pm 2\%$ of end scale on the 413A meter.

5-40. PERFORMANCE VERIFICATION.

5-41. The following procedure is to verify proper operation and should be accomplished with the instrument in its cabinet. This check may be made as a final test for routine maintenance or as a part of your incoming quality control inspection to verify listed specifications. If the instrument fails any of the following tests, refer to paragraph 5-29, Adjustment Procedure. Proceed as follows:

Note

The following procedures assume correct mechanical zero on the 413A meter (paragraph 5-31).

5-42. VOLTMETER.

- a. Turn the voltmeter calibration generator on and allow a 20-minute warmup.
- b. Switch the voltmeter calibrator function switch to OFF, and connect the output connectors to the 413A INPUT as shown in figure 5-9.

5-7

c. Connect the 413A to the variable power source, set line voltage to rated value (115 or 230 volts) and turn the 413A ON. Allow 15 minutes for the instrument to warm up.

d. Turn 413A RANGE (VOLTS) switch fully clockwise (one step past 1000), and observe the 413A meter.

e. Adjust R116, Bias Adjust, for a zero indication $\pm 20\%$ on the meter (see paragraph 5-34).

f. Switch 413A ZERO to NORMAL, and adjust the ZERO control for an exact zero reading on the 413A meter.

g. Switch 413A RANGE (VOLTS) to 300, and set voltmeter calibrator output to +300 volts dc.

WARNING

The 738AR Voltmeter Calibrator output is a constant voltage source and can be dangerous! Be careful not to touch the output leads without first tuning OUTPUT SELECTOR to OFF.

h. The 413A meter should read +300 volts $\pm 2\%$ of end scale.

i. Vary line voltage between 103 and 127 volts. Meter reading should be unaffected.

j. Repeat steps h and i for -300 volts.

k. Check end scale readings for the remaining ranges. Specifications are $\pm 2\%$ of end scale.

m. Switch 413A RANGE (VOLTS) to 1; set voltmeter calibrator range and function switches for 1 volt dc out.

n. Check meter tracking in 1/10 volt increments for both plus and minus input voltages. Meter tracking should be correct within $\pm 2\%$ of end scale.

Note

When checking the 413A on the .003 and .001 volt ranges, set the voltmeter calibrator selector switch to OFF and reset ZERO control for a meter reading of zero.

5-43. AC REJECTION.

a. With 413A INPUT open, set 413A RANGE (VOLTS) to .03. Set ZERO for a zero indication on the 413A meter.

b. Connect a source of 6.3 volts ac (with no dc level) across the 413A input. Any change in the 413A meter reading should be less than 1%.

5-44. AMPLIFIER OUTPUT.

a. Connect a voltmeter calibrator and the accuracy indicator (paragraph 5-37) to the 413A as shown in figure 5-10.

b. Switch accuracy indicator range switch to .03.

c. Set 413A RANGE (VOLTS) switch to 1.

d. Switch voltmeter calibrator function and range switches to +1 volt.

e. Accuracy indicator should indicate less than 1.5% error.

f. Repeat steps a to d for -1 volt.

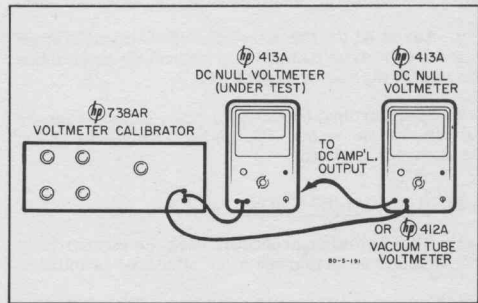

Figure 5-10. Performance Test (Amplifier) Setup

SERVICING ETCHED CIRCUIT BOARDS

Excessive heat or pressure can lift the copper strip from the board. Avoid damage by using a low power soldering iron (50 watts maximum) and following these instructions. Copper that lifts off the board should be cemented in place with a quick drying acetate base cement having good electrical insulating properties.

A break in the copper should be repaired by soldering a short length of tinned copper wire across the break.

Use only high quality rosin core solder when repairing etched circuit boards. NEVER USE PASTE FLUX. After soldering, clean off any excess flux and coat the repaired area with a high quality electrical varnish or lacquer.

When replacing components with multiple mounting pins such as tube sockets, electrolytic capacitors, and potentiometers, it will be necessary to lift each pin slightly, working around the components several times until it is free.

WARNING: If the specific instructions outlined in the steps below regarding etched circuit boards without eyelets are not followed, extensive damage to the etched circuit board will result.

1. Apply heat sparingly to lead of component to be replaced. If lead of component passes through an eyelet in the circuit board, apply heat on component side of board. If lead of component does not pass through an eyelet, apply heat to conductor side of board.

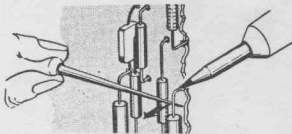

2. Reheat solder in vacant eyelet and quickly insert a small awl to clean inside of hole. If hole does not have an eyelet, insert awl or a #57 drill from conductor side of board.

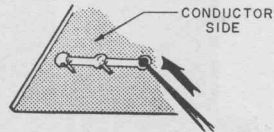

3. Bend clean tinned leads on new part and carefully insert through eyelets or holes in board.

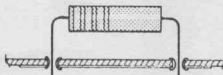

4. Hold part against board (avoid overheating) and solder leads. Apply heat to component leads on correct side of board as explained in step 1.

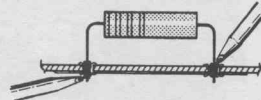

In the event that either the circuit board has been damaged or the conventional method is impractical, use method shown below. This is especially applicable for circuit boards without eyelets.

1. Clip lead as shown below.

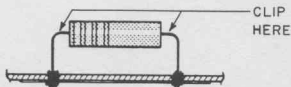

2. Bend protruding leads upward. Bend lead of new component around protruding lead. Apply solder using a pair of long nose pliers as a heat sink.

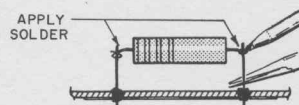

This procedure is used in the field only as an alternate means of repair. It is not used within the factory.

Figure 5-11. Servicing Etched Circuit Boards

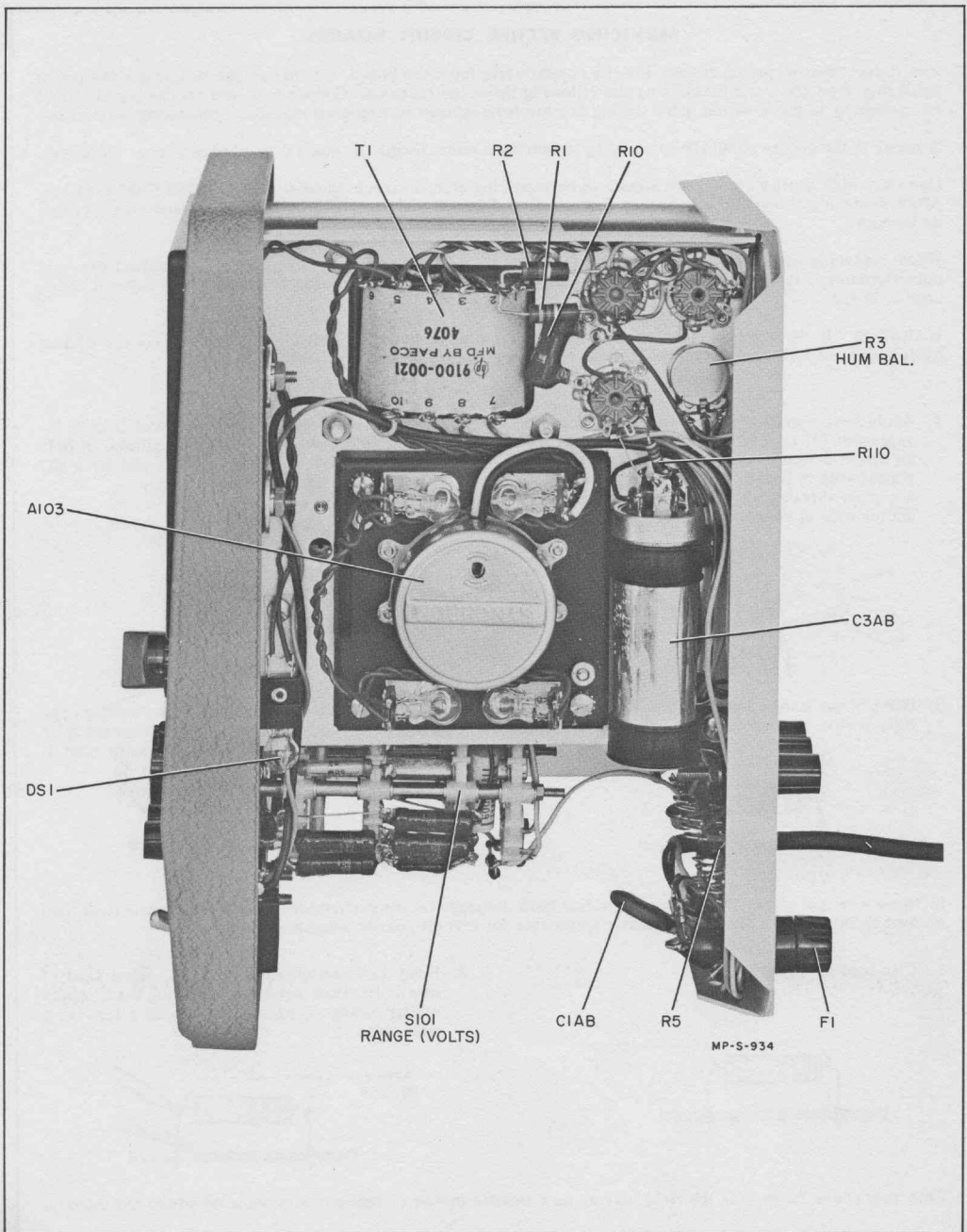

Figure 5-12. Model 413A Right Side View

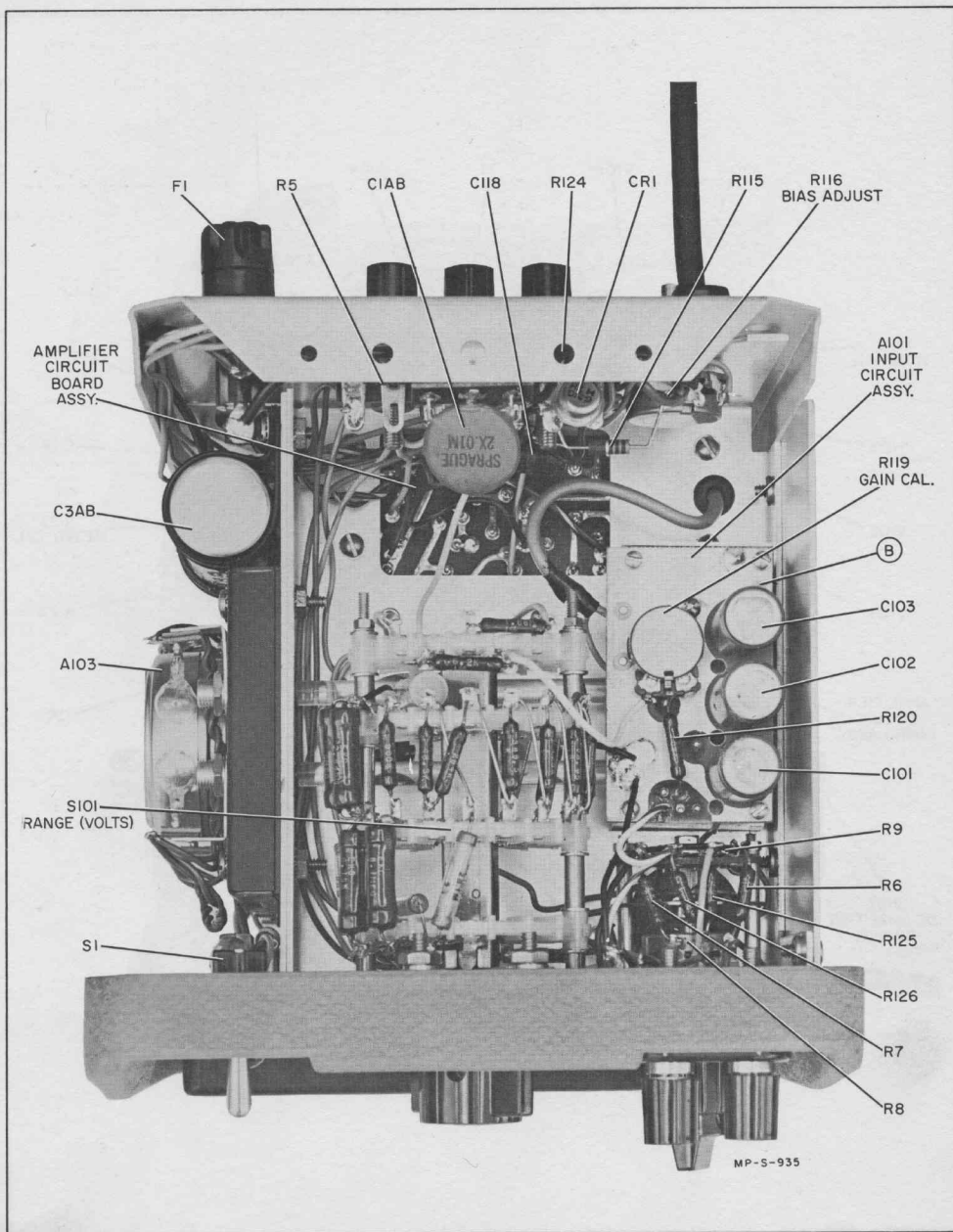
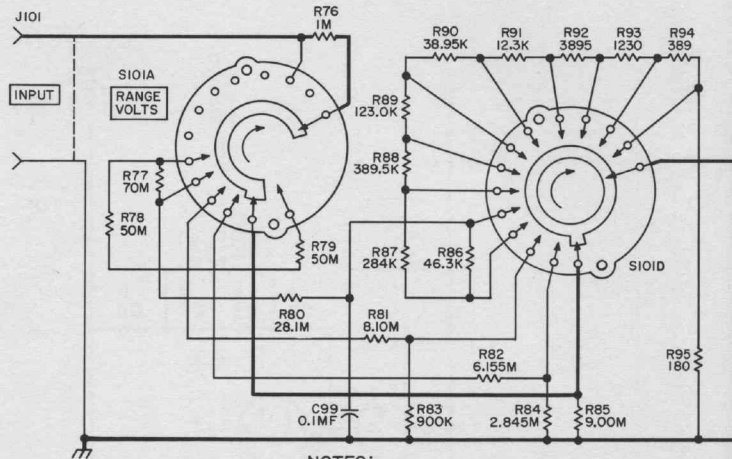
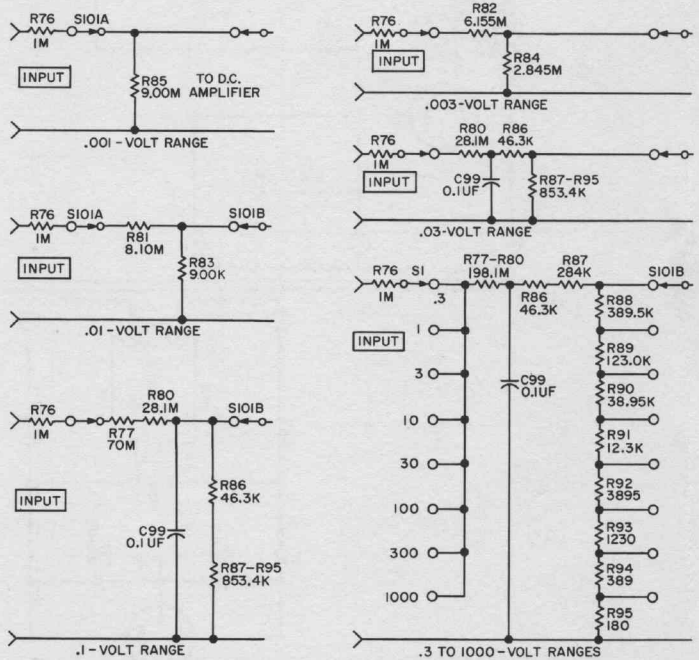

Figure 5-14. Model 413A Bottom View



NOTES:

1. DC VOLTAGES REFERENCED TO ⏏ WITH LINE VOLTAGE AT 115V AND NO METER DEFLECTION.
2. ALL RESISTANCE VALUES IN OHMS, CAPACITANCE IN PF UNLESS OTHERWISE NOTED.
3. ⏏ = FLOATING CHASSIS GROUND. ⏏ = CABINET GROUND.
4. SWITCHES SHOWN FULLY CCW VIEWED FROM FRONT PANEL.
5. SIMPLIFIED DIAGRAMS FOR S101A & S101B SHOWN BELOW.



SIMPLIFIED DIAGRAM OF S101A & S101B SWITCHING

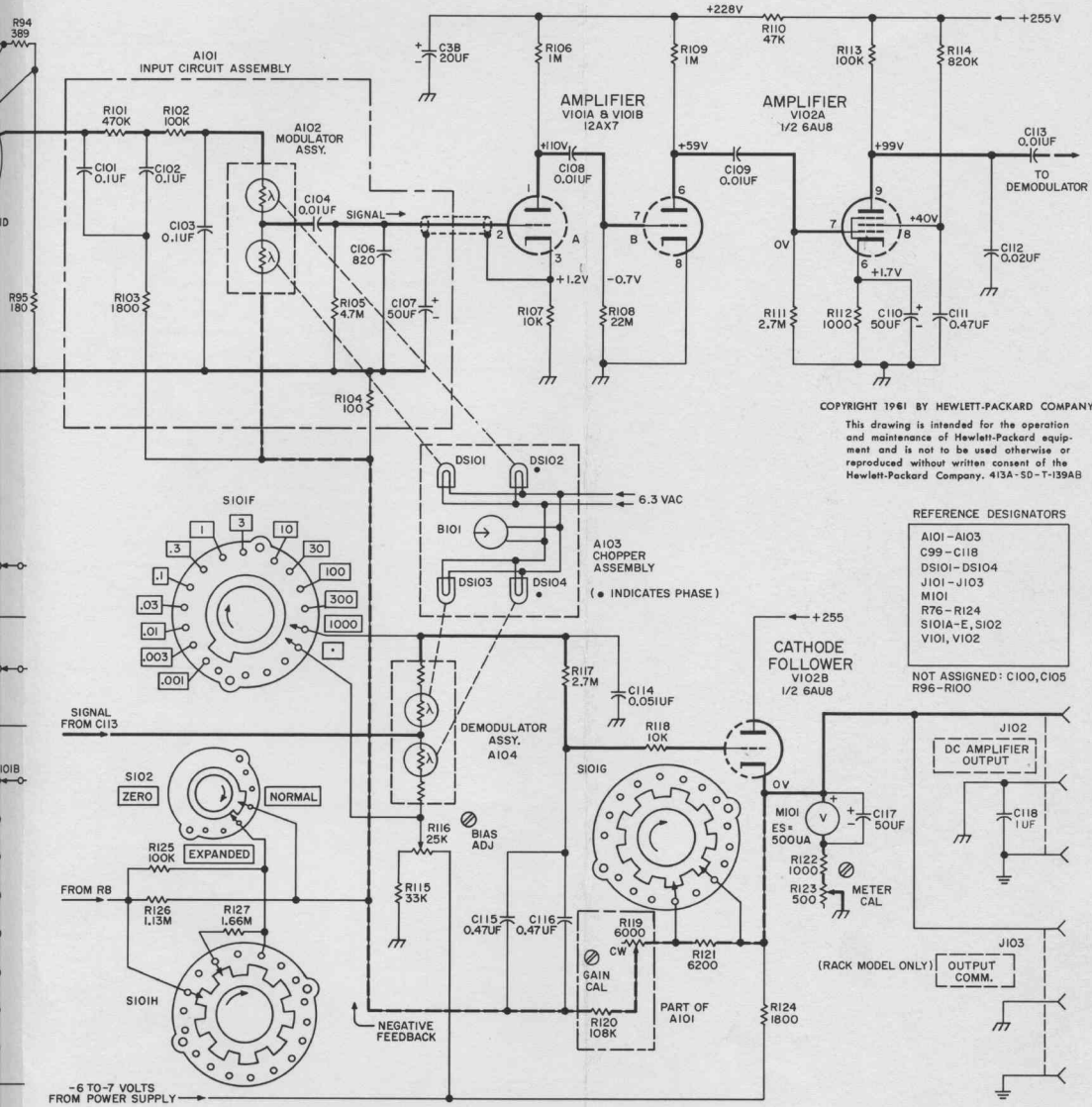

COPYRIGHT 1961 BY HEWLETT-PACKARD COMPANY
This drawing is intended for the operation and maintenance of Hewlett-Packard equipment and is not to be used otherwise or reproduced without written consent of the Hewlett-Packard Company. 413A-SD-T-139AB

Figure 5-15. Model 413A DC Null Voltmeter

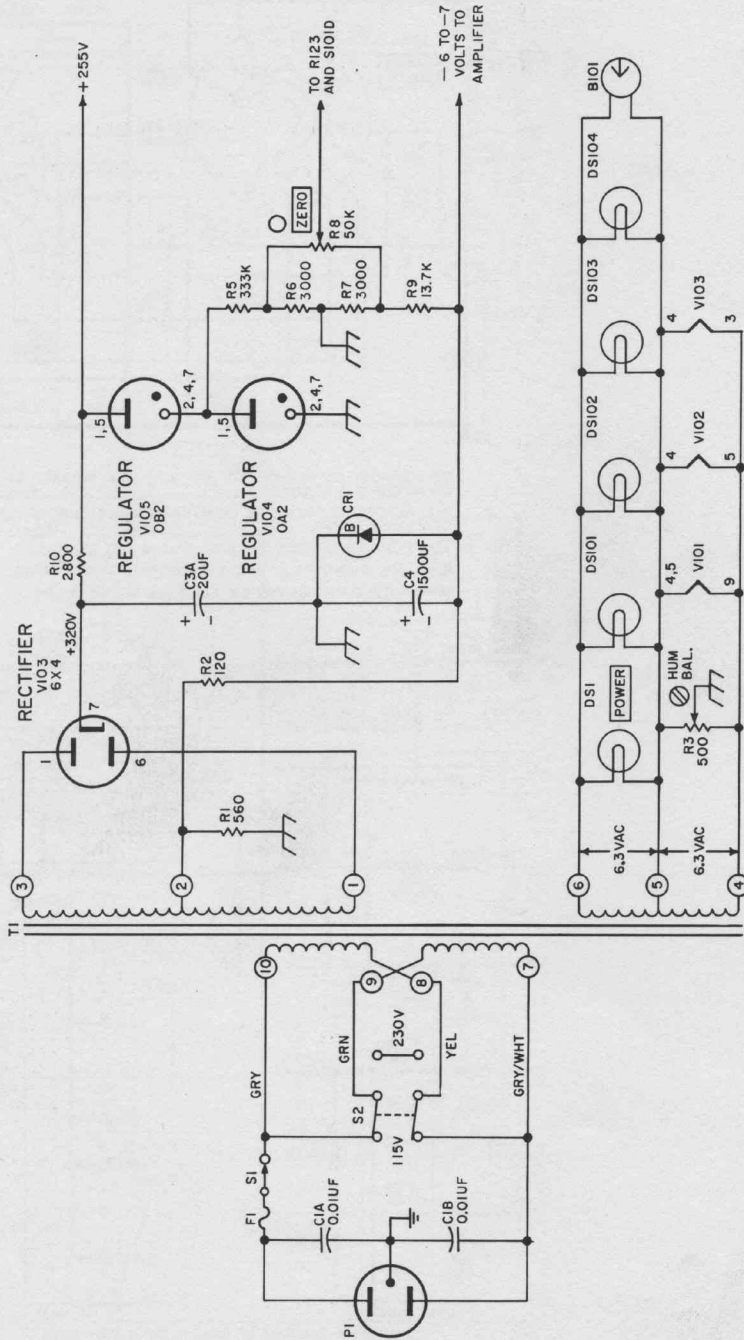

REFERENCE DESIGNATORS

B101
C1, C3, C4
CRI
DS1, DS101-DS104
F1
R1-R3, R5-R10
S1, S2
V1-V3

DELETED: C2, R4

COPYRIGHT 1961 BY HEWLETT-PACKARD COMPANY

This drawing is intended for the operation and maintenance of Hewlett-Packard equipment and is not to be used otherwise or reproduced without written consent of the Hewlett-Packard Company.
413A-PS-1-135AB

NOTES:

1. ALL R VALUES IN OHMS; UNLESS OTHERWISE STATED.
2. = FLOATING CHASSIS GROUND
 = CABINET GROUND

Figure 5-16. Power Supply

SECTION VI REPLACEABLE PARTS

6-1. INTRODUCTION.

6-2. This section contains information for ordering replacement parts. Table 6-1 lists parts in alpha-numerical order of their reference designators and indicates the description and Φ stock number of each part, together with any applicable notes. Table 6-2 lists parts in alpha-numerical order of their Φ stock numbers and provides the following information on each part:

- a. Description of the part (see list of abbreviations below).
- b. Manufacturer of the part in a five-digit code; see list of manufacturers in appendix.
- c. Typical manufacturer's stock number.
- d. Total quantity used in the instrument (TQ column).
- e. Recommended spare part quantity for complete maintenance during one year of isolated service (RS column).

6-3. Miscellaneous parts not indexed in table 6-1 are listed at the end of table 6-2.

6-4. ORDERING INFORMATION.

6-5. To order a replacement part, address order or inquiry either to your authorized Hewlett-Packard sales representative or to

CUSTOMER SERVICE
Hewlett-Packard Company
395 Page Mill Road
Palo Alto, California

or, in Western Europe, to

Hewlett-Packard S.A.
Rue du Vieux Billard No. 1
Geneva, Switzerland.

- 6-6. Specify the following information for each part:
- a. Model and complete serial number of instrument.
 - b. Hewlett-Packard stock number.
 - c. Circuit reference designator.
 - d. Description.

6-7. To order a part not listed in tables 6-1 and 6-2, give a complete description of the part and include its function and location.

REFERENCE DESIGNATORS

A = assembly B = motor C = capacitor CR = diode DL = delay line DS = device signaling (lamp) E = misc electronic part	F = fuse FL = filter J = jack K = relay L = inductor M = meter	P = plug Q = transistor R = resistor RT = thermistor S = switch T = transformer	V = vacuum tube, neon bulb, photocell, etc. W = cable X = socket XF = fuseholder XV = tube socket XDS = lampholder
---	---	--	---

ABBREVIATIONS

bp = bandpass bwo = backward wave oscillator c = carbon cer = ceramic cmo = cabinet mount only coef = coefficient com = common comp = composition conn = connection crt = cathode-ray tube dep = deposited det = detector EIA = Tubes and transistors selected for best performance will be supplied if ordered by Φ stock numbers; tubes or transistors meeting Electronic Industries' Association standards will normally result in instrument operating within specifications	elect = electrolytic encap = encapsulated f = farads fxd = fixed Ge = germanium grd = ground (ed) h = henries Hg = mercury impg = impregnated lncd = incandescent ins = insulation (ed) K = kilo lin = linear taper log = logarithmic taper m = milli = 10^{-3} M = megohms ma = milliamperes minat = miniature mfg = metal film on glass mfr = manufacturer	mtg = mounting my = mylar NC = normally closed Ne = neon NO = normally open NPO = negative positive zero-zero temperature coefficient nsr = not separately replaceable obd = order by description p = peak pc = printed circuit board pf = picofarads = 10^{-12} farads pp = peak-to-peak piv = peak inverse voltage pos = position(s) poly = polystyrene pot = potentiometer rect = rectifier	rot = rotary rms = root-mean-square rmo = rack mount only s-b = slow-blow Se = selenium sect = section(s) Si = silicon sl = slide td = time delay TiO ₂ = titanium dioxide tog = toggle tol = tolerance trim = trimmer twt = traveling wave tube var = variable w/ = with W = watts ww = wirewound w/o = without * = optimum value selected at factory, average value shown (part may be omitted)
---	---	--	---

01194-3

Table 6-1. Reference Designation Index

Circuit Reference	Ⓜ Stock No.	Description #	Note
A1 thru A100		Not assigned	
A101	412A-58A	Assy, input circuit, includes: A102 R101 thru R105 C101 thru C104 R119 C106 R120 C107	
A102	412A-95A	Assy, modulator	
A103	425A-97A	Assy, chopper: includes B 101, DS101 thru DS104	
A104	412A-23B	Assy, demodulator	
A105	413A-19A	Assy, range switch: includes C99, R76 thru R95, R121, R127, S101	
A106	413A-19B	Assy, switch, zero: includes R6 thru R9, R125, R126, S102	
B1 thru B100		Not assigned	
B101	3140-0013	Motor: 6.3 VAC	
C1A/B	0150-0119	C: fxd, cer, 0.01 uf/sect, ±20%, 250 vdcw	
C2		Not assigned	
C3A/B	0180-0086	C: fxd, elect, 2 sect, 20 uf/sect, 450 vdcw	
C4	0180-0054	C: fxd, elect, 1500 uf, 10 vdcw	
C5 thru C98		Not assigned	
C99	0170-0019	C: fxd, my, 0.1 uf ± 5%, 200 vdcw	
C100		Not assigned	
C101 thru C103	0170-0030	C: fxd, poly, 0.1 uf ± 1%, 50 vdcw	
C104	0170-0029	C: fxd, poly, 0.01 uf ± 10%, 50 vdcw	
C105		Not assigned	
C106	0140-0010	C: fxd, mica, 820 pf ± 10%, 500 vdcw	
C107	0180-0033	C: fxd, elect, 50 uf, 6 vdcw	
C108, 109	0150-0012	C: fxd, cer, 0.01 uf ± 20%, 1000 vdcw	
C110	0180-0033	C: fxd, elect, 50 uf, 6 vdcw	
C111	0160-0015	C: fxd, paper, 0.47 uf ± 10%, 200 vdcw	
C112	0150-0024	C: fxd, cer, 0.02 uf +80%, -20%, 600 vdcw	
C113	0150-0012	C: fxd, cer, 0.01 uf ± 20%, 1000 vdcw	

See introduction to this section

Table 6-1. Reference Designation Index (Cont'd)

Circuit Reference	Ⓢ Stock No.	Description #	Note
C114	0170-0003	C: fxd, my, 0.051 uf ± 10%, 200 vdcw	
C115, 116	0160-0015	C: fxd, paper, 0.47 uf ± 10%, 200 vdcw	
C117	0180-0105	C: fxd, elect, 50 uf, 25 vdcw	
C118	0170-0022	C: fxd, my, 0.1 uf ± 20%, 600 vdcw	
CR1	G-31G-7H	Diode: breakdown	
DS1	2140-0012	Lamp, minat: 2 pin, no. 12	
DS2 thru DS100		Not assigned	
DS101 thru DS104	2140-0012	Lamp, minat: 2 pin, no. 12	
F1	2110-0020	Fuse, cartridge: 0.8 amp, s-b (for 115V operation)	
	2110-0018	Fuse, cartridge: 0.25 amp, s-b (for 230V operation)	
J1 thru J100		Not assigned	
J101	AC-10C	Binding post: black	
	AC-10D	Binding post: red	
	AC-54A	Insulator: binding post, black, 2 hole	
	AC-54E	Insulator: binding post, black, 2 hole	
J102	AC-10C	Binding post: black	
	AC-10C	Binding post: black	
	AC-10D	Binding post: red	
	AC-54B	Insulator: binding post, black, 3 hole	
	AC-54F	Insulator: binding post, black, 3 hole	
J103	AC-10C	Binding post: black (rmo)	
	AC-10C	Binding post: black (rmo)	
	AC-10D	Binding post: red (rmo)	
	AC-54B	Insulator: binding post, black, 3 hole (rmo)	
	AC-54F	Insulator: binding post, black, 3 hole (rmo)	
M1 thru M100		Not assigned	
M101	413A-81A	Meter, calibrated	
P1	8120-0050	Cord, power: w/NEMA plug	
R1	0690-5611	R: fxd, comp, 560 ohms ± 10%, 1W	
R2	0690-1211	R: fxd, comp, 120 ohms ± 10%, 1 W	

See introduction to this section

Table 6-1. Reference Designation Index (Cont'd)

Circuit Reference	Ⓢ Stock No.	Description#	Note
R3	2100-0078	R: var, ww, lin, 500 ohms \pm 30%, 3/10W	
R4		Not assigned	
R5	0727-0233	R: fxd, dep c, 333K ohms \pm 10%, 1/2 W	
R6, R7	0727-0124	R: fxd, dep c, 3K ohms \pm 1%, 1/2 W	
R8		nsr; part of S102	
R9	0727-0167	R: fxd, dep c, 13.7K ohms \pm 1%, 1/2 W	
R10	0813-0018	R: fxd, ww, 2.8K ohms \pm 10%, 5W	
R11 thru R75		Not assigned	
R76	0727-0274	R: fxd, dep c, 1 M \pm 1%, 1/2 W	
R77	0733-0014	R: fxd, dep c, 70M \pm 1/2%, 2W	
R78, 79	0730-0150	R: fxd, dep c, 50M \pm 1/2%, 1W	
R80	0730-0149	R: fxd, dep c, 28.1M \pm 1/2%, 1W	
R81	0730-0134	R: fxd, dep c, 8.1M \pm 1/2%, 1W	
R82	0730-0128	R: fxd, dep c, 6.155M \pm 1/2%, 1W	
R83	0727-0262	R: fxd, dep c, 900K ohms \pm 1/2%, 1/2W	
R84	0730-0117	R: fxd, dep c, 2.845M \pm 1/2%, 1W	
R85	0730-0139	R: fxd, dep c, 9M \pm 1/2%, 1W	
R86	0727-0192	R: fxd, dep c, 46.3K ohms \pm 1/2%, 1/2W	
R87	0727-0231	R: fxd, dep c, 284K ohms \pm 1/2%, 1/2W	
R88	0727-0239	R: fxd, dep c, 389.5K ohms \pm 1/2%, 1/2W	
R89	0727-0215	R: fxd, dep c, 123K ohms \pm 1/2%, 1/2W	
R90	0727-0188	R: fxd, dep c, 38.95K ohms \pm 1/2%, 1/2W	
R91	0727-0164	R: fxd, dep c, 12.3K ohms \pm 1/2%, 1/2W	
R92	0727-0130	R: fxd, dep c, 3895 ohms \pm 1/2%, 1/2W	
R93	0727-0106	R: fxd, dep c, 1230 ohms \pm 1/2%, 1/2W	
R94	0727-0070	R: fxd, dep c, 389 ohms \pm 1/2%, 1/2W	
R95	0727-0051	R: fxd, dep c, 180 ohms \pm 1/2%, 1/2W	
R96 thru R100		Not assigned	
R101	0687-4741	R: fxd, comp, 470K ohms \pm 10%, 1/2W	
R102	0687-1041	R: fxd, comp, 100K ohms \pm 10%, 1/2W	

See introduction to this section

Table 6-2. Reference Designation Index (Cont'd)

Circuit Reference	Ⓢ Stock No.	Description #	Note
R103	0687-1821	R: fxd, comp, 1.8K ohms \pm 10%, 1/2W	
R104	0727-0043	R: fxd, dep c, 100 ohms \pm 1%, 1/2W	
R105	0687-4751	R: fxd, comp, 4.7M \pm 10%, 1/2W	
R106	0687-1051	R: fxd, comp, 1M \pm 10%, 1/2W	
R107	0687-1031	R: fxd, comp, 10K ohms \pm 10%, 1/2W	
R108	0687-2261	R: fxd, comp, 22M \pm 10%, 1/2W	
R109	0687-1051	R: fxd, comp, 1M \pm 10%, 1/2W	
R110	0687-4731	R: fxd, comp, 47K ohms \pm 10%, 1/2W	
R111	0687-2751	R: fxd, comp, 2.7M \pm 10%, 1/2W	
R112	0687-1021	R: fxd, comp, 1K ohms \pm 10%, 1/2W	
R113	0687-1041	R: fxd, comp, 100K ohms \pm 10%, 1/2W	
R114	0687-8241	R: fxd, comp, 820K ohms \pm 10%, 1/2W	
R115	0687-3331	R: fxd, comp, 33K ohms \pm 10%, 1/2W	
R116	2100-0009	R: var, comp, 25K ohms \pm 20%, 1/3W	
R117	0687-2751	R: fxd, comp, 2.7M \pm 10%, 1/2W	
R118	0687-1031	R: fxd, comp, 10K ohms \pm 10%, 1/2W	
R119	2100-0136	R: var, comp, lin, 6K ohms \pm 20%, 3/10W	
R120	0727-0209	R: fxd, dep c, 108K ohms \pm 1%, 1/2W	
R121	0727-0142	R: fxd, dep c, 6.2K ohms \pm 10%, 1/2W	
R122	0727-0100	R: fxd, dep c, 1K ohms \pm 1%, 1/2W	
R123	2100-0022	R: var, ww, lin, 500 ohms \pm 20%, 1W	
R124	0687-1821	R: fxd, comp, 1.8K ohms \pm 10%, 1/2 W	
R125	0727-0208	R: fxd, dep c, 100K ohms \pm 1%, 1/2W	
R126	0727-0278	R: fxd, dep c, 1.13M \pm 1%, 1/2W	
R127	0727-0283	R: fxd, dep c, 1.66M \pm 1%, 1/2W	
S1	3101-0001	Switch, tog: SPST	
S2	3101-0033	Switch, sl: DPDT	
S3 thru S100		Not assigned	
S101		nsr; part of range switch assy, A105	
S102	3100-0290	Switch, rot: 1 sect, 2 pos, w/R8 var resistor	

See introduction to this section

Table 6-1. Reference Designation Index (Cont'd)

Circuit Reference	Ⓟ Stock No.	Description #	Note
T1	9100-0021	Transformer, power	
V1 thru V100		Not assigned	
V101	1932-0030	Tube, electron: 12AX7	
V102	1933-0007	Tube, electron: 6AU8	
V103	1930-0016	Tube, electron: 6X4	
V104	1940-0004	Tube, electron: 0A2	
V105	1940-0007	Tube, electron: 0B2	
XDS1	1450-0022	Lampholder (rmo)	
	1450-0043	Lampholder (cmo)	
XF1	1400-0084	Fuseholder	
XV1 thru XV 100		Not assigned	
XV101	1200-0048	Socket, tube: 9 pin	
XV102	1200-0059	Socket, tube: 9 pin, minat	
XV103 thru XV105	1200-0009	Socket, tube: 7 pin, minat	
		<u>MISCELLANEOUS</u>	
	G-74G	Knob, black: 1 in. ZERO CONTROL	
	G-74N	Knob, bar w/arrow RANGE (volts) SWITCH	
	G-74AT	Knob, red: 3/4 in. bar w/arrow NORMAL EXPAND SWITCH	
	412A-37A	Light rod: modulator (cmo)	
	412A-37B	Light rod: modulator (rmo)	
	412A-65A	Assy, amplifier	
	412A-65A-1	Circuit board, amplifier: includes C108 thru C110 R111 thru R114 C112 V101 C113 V102 R106 thru R109	

See introduction to this section

Table 6-2. Replaceable Parts

Stock No.	Description #	Mfr.	Mfr. Part No.	TQ	RS
AC-10C	Binding post: black (cmo) (rmo)	28480	AC-10C	3 5	1
AC-10D	Binding post: red (cmo) (rmo)	28480	AC-10D	2 3	1
AC-54A	Insulator: Binding post, black, 2 hole	28480	AC-54A	1	0
AC-54B	Insulator: Binding post, black, 3 hole (cmo) (rmo)	28480	AC-54B	1 2	0
AC-54E	Insulator: Binding post, black, 2 hole	28480	AC-54E	1	0
AC-54F	Insulator: Binding post, black, 3 hole (cmo) (rmo)	28480	AC-54F	1 2	0
G-31G-7H	Diode: breakdown	28480	G-31G-7H	1	1
412A-23B	Assy, demodulator	28480	412A-23B	1	1
412A-58A	Assy, input circuit, includes: A102, C101 thru C104, C106, C107, R101 thru R105, R119, R120	28480	412A-58A	1	1
412A-95A	Assy, modulator	28480	412A-95A	1	1
413A-19A	Assy switch, range: includes: C99, R76 thru R95, R121, R127, S101	28480	413A-19A	1	1
413A-19B	Assy switch, zero: includes: R6 thru R9, R125, R126, S102	28480	413A-19B	1	1
413A-81A	Meter, calibrated	28480	413A-81A	1	1
425A-97A	Assy chopper: includes B101, DS101 thru DS104	28480	425A-97A	1	1
0140-0010	C: fxd, mica, 820 pf \pm 10%, 500 vdcw	76433	RCM20B821K	1	1
0150-0012	C: fxd, cer, 0.01 uf \pm 20%, 1000 vdcw	56289	29C214A3-H-1038	3	1
0150-0024	C: fxd, cer, 0.02 uf +80% -20%, 600 vdcw	91418	B.02 GMV	1	1
0150-0119	C: fxd, cer, 2 sect., 0.01 uf/sect \pm 20%, 250 vdcw	71590	DA171CB	1	1
0160-0015	C: fxd, paper, 0.47 uf \pm 10%, 200 vdcw	56289	109P47492	3	1
0170-0003	C: fxd, my, 0.051 uf \pm 10%, 200 vdcw	00853	33M02151	1	1
0170-0019	C: fxd, my, 0.1 uf \pm 5%, 200 vdcw	84411	620S	1	1
0170-0022	C: fxd, my, 0.1 uf \pm 20%, 600 vdcw	56289	S92684	1	1
0170-0029	C: fxd, poly, 0.01 uf \pm 10%, 50 vdcw	56289	114P1039R5S2	1	1
0170-0030	C: fxd, poly, 0.1 uf \pm 10%, 50 vdcw	56289	Type 114P Style T15	3	1

See introduction to this section

Table 6-2. Replaceable Parts (Cont'd)

④ Stock No.	Description#	Mfr.	Mfr. Part No.	TQ	RS		
0180-0033	C: fxd, elect, 50 uf, 6 vdcw	56289	30D133A1	2	1		
0180-0054	C: fxd, elect, 1500 uf, 10 vdcw	56289	D32495	1	1		
0180-0086	C: fxd, elect, 2 sect, 20 uf/sect, 450 vdcw	00853	Type PL1	1	1		
0180-0105	C: fxd, elect, 50 uf, 25 vdcw	56289	S97441	1	1		
0687-1021	R: fxd, comp, 1K ohms ± 10%, 1/2W	01121	EB1021	1	1		
0687-1031	R: fxd, comp, 10K ohms ± 10%, 1/2W	01121	EB1031	2	1		
0687-1041	R: fxd, comp, 100K ohms ± 10%, 1/2W	01121	EB1041	2	1		
0687-1051	R: fxd, comp, 1M ± 10%, 1/2W	01121	EB1051	2	1		
0687-1821	R: fxd, comp, 1.8K ohms ± 10%, 1/2W	01121	EB1821	2	1		
0687-2261	R: fxd, comp, 22M ± 10%, 1/2W	01121	EB2261	1	1		
0687-2751	R: fxd, comp, 2.7M ± 10%, 1/2W	01121	EB2751	2	1		
0687-3331	R: fxd, comp, 33K ohms ± 10%, 1/2W	01121	EB3331	1	1		
0687-4731	R: fxd, comp, 47K ohms ± 10%, 1/2W	01121	EB4731	1	1		
0687-4741	R: fxd, comp, 470K ohms ± 10%, 1/2W	01121	EB4741	1	1		
0687-4751	R: fxd, comp, 4.7 m ± 10%, 1/2W	01121	EB4751	1	1		
0687-8241	R: fxd, comp, 820K ohms ± 10%, 1/2W	01121	EB8241	1	1		
0690-1211	R: fxd, comp., 120 ohms ± 10%, 1W	01121	GB1211	1	1		
0690-5611	R: fxd, comp, 560 ohms ± 10%, 1W	01121	GB5611	1	1		
0727-0043	R: fxd, dep c, 100 ohms ± 1%, 1/2W	19701	DC 1/2 BR5, obd#	1	1		
0727-0051	R: fxd, dep c, 180 ohms ± 1/2W	19701	DC 1/2 AR5, obd#	1	1		
0727-0070	R: fxd, dep c, 389 ohms ± 1/2%, 1/2W	19701	DC 1/2 AR5, obd#	1	1		
0727-0100	R: fxd, dep c, 1K ohms ± 1%, 1/2W	19701	DC 1/2 CR5, obd#	1	1		
0727-0106	R: fxd, dep c, 1.23K ohms ± 1/2%, 1/2W	19701	DC 1/2 AR5, obd#	1	1		
0727-0124	R: fxd, dep c, 3K ohms ± 1%, 1/2W	19701	DC 1/2 CR5, obd#	2	1		
0727-0130	R: fxd, dep c, 3895 ohms ± 1/2%, 1/2W	19701	DC 1/2 AR5, obd#	1	1		
0727-0142	R: fxd, dep c, 6.2K ohms ± 1%, 1/2W	19701	DC 1/2 AR5, obd#	1	1		
0727-0164	R: fxd, dep c, 12.3K ohms ± 1/2%, 1/2W	19701	DC 1/2 AR5, obd#	1	1		
0727-0167	R: fxd, dep c, 13.7K ohms ± 1%, 1/2W	19701	DC 1/2 CR5, obd#	1	1		
0727-0188	R: fxd, dep c, 38,950 ohms, ± 1%, 1/2W	19701	DC 1/2 AR5, obd#	1	1		
0727-0192	R: fxd, dep c, 46.3K ohms ± 1/2%, 1/2W	19701	DC 1/2 CR5, obd#	1	1		

See introduction to this section

Table 6-2. Replaceable Parts (Cont'd)

Stock No.	Description #	Mfr.	Mfr. Part No.	TQ	RS		
0727-0208	R: fxd, dep c, 100K ohms $\pm 1\%$, 1/2W	19701	DC 1/2 CR5, obd#	1	1		
0727-0209	R: fxd, dep c, 108K ohms $\pm 1\%$, 1/2W	19701	DC 1/2 AR5, obd#	1	1		
0727-0215	R: fxd, dep c, 123K ohms $\pm 1/2\%$, 1/2W	19701	DC 1/2 AR5, obd#	1	1		
0727-0231	R: fxd, dep c, 284K ohms $\pm 1/2\%$, 1/2W	19701	DC 1/2 AR5, obd#	1	1		
0727-0233	R: fxd, dep c, 333K ohms $\pm 1\%$, 1/2W	19701	DC 1/2 AR5, obd#	1	1		
0727-0239	R: fxd, dep c, 389.5K ohms $\pm 1/2\%$, 1/2W	19701	DC 1/2 AR5, obd#	1	1		
0727-0262	R: fxd, dep c, 900K ohms $\pm 1/2\%$, 1/2W	19701	DC 1/2 AR5, obd#	1	1		
0727-0274	R: fxd, dep c, 1M $\pm 1\%$, 1/2W	19701	DC 1/2 AR5, obd#	1	1		
0727-0278	R: fxd, dep c, 1.13M $\pm 1\%$, 1/2W	19701	DC 1/2 CR5, obd#	1	1		
0727-0283	R: fxd, dep c, 1.66M $\pm 1\%$, 1/2W	19701	DC 1/2 AR5, obd#	1	1		
0730-0117	R: fxd, dep c, 2.845M $\pm 1\%$, 1W	19701	DC 1 R5, obd#	1	1		
0730-0128	R: fxd, dep c, 6.155M $\pm 1\%$, 1W	19701	DC 1 R5, obd#	1	1		
0730-0134	R: fxd, dep c, 8.1M $\pm 1/2\%$, 1W	19701	DC 1 R5, obd#	1	1		
0730-0139	R: fxd, dep c, 9M $\pm 1/2\%$, 1W	19701	DC 1 R5, obd#	1	1		
0730-0149	R: fxd, dep c, 28.1M $\pm 1/2\%$, 1W	03888	PT1000, obd#	1	1		
0730-0150	R: fxd, dep c, 50M $\pm 1/2\%$, 1W	03888	PT1000, obd#	2	1		
0733-0014	R: fxd, dep c, 70M $\pm 1\%$, 2W	03888	PT2000, obd#	1	1		
0813-0018	R: fxd, ww, 2.8K ohms $\pm 10\%$, 5W	35434	C-5-2800	1	1		
1200-0009	Socket, tube: 7 pin, minat	91662	316PH-3702	3	1		
1200-0048	Socket, tube: 9 pin	91662	3908-2-4	1	1		
1200-0059	Socket, tube: 9 pin, minat	71785	121-51-11-082	1	1		
1400-0084	Fuseholder	75915	342014	1	1		
1450-0022	Lampholder (rmo)	72765	2020-AE	1	1		
1450-0043	Lampholder (cmo)	0000W					
1930-0016	Tube, electron: 6x4	80131	6x4	1	1		
1932-0030	Tube, electron: 12AX7	80131	12AX7	1	1		
1933-0007	Tube, electron: 6AU8	80131	6AU8	1	1		
1940-0004	Tube, electron: OA2	80131	OA2	1	1		
1940-0007	Tube, electron: OB2	80131	OB2	1	1		
2100-0009	R: var, comp, 25K ohms $\pm 20\%$, 1/3W	11237	Type 45, obd#	1	1		

See introduction to this section

Table 6-2. Replaceable Parts (Cont'd)

Stock No.	Description	Mfr.	Mfr. Part No.	TQ	RS		
2100-0022	R: var, ww, lin, 500 ohms \pm 20%, 1W	11236	Type 112, obd#	1	1		
2100-0078	R: var, ww, lin, 500 ohms \pm 30%, 3/10W	11237	70C3837	1	1		
2100-0136	R: var, comp, lin, 6K ohms \pm 20%, 3/10W	11237	Type 70, obd#	1	1		
2110-0018	Fuse, cartridge: 0.25 amp, s-b, (for 230 volt operation)	71400	MDL 1/4				
2110-0020	Fuse, cartridge: 0.8 amp, s-b, (for 115 volt operation)	75915	313-800	1	10		
2140-0012	Lamp, minat: 2 pin, No. 12	24455	No. 12	5	5		
3100-0290	Switch, rot, 1 sect, 2 pos, w/R8 var resistor	76854	218429-K1P	1	1		
3101-0001	Switch, tog: SPST	04009	80994-H	1	1		
3101-0033	Switch, sl: DPDT	42190	4633	1	1		
3140-0013	Motor: 6.3, VAC	73061	"Synchron" Model 610 (6.3V)	1	1		
8120-0050	Cord, power: w/NEMA plug	70903	CS-0041/PH- 151/7.5 ft	1	1		
9100-0021	Transformer, power	98734	4076	1	1		
<u>MISCELLANEOUS</u>							
G-74G	Knob, black: 1 in. ZERO CONTROL						
G-74N	Knob, bar w/arrow RANGE (volts) SWITCH						
G-74AT	Knob, red: 3/4 in. bar w/arrow NORMAL EXPAND SWITCH						
412A-37A	Light rod: modulator (cmo)						
412A-37B	Light rod: modulator (rmo)						
412A-65A	Assy, amplifier						
412A-65A-1	Circuit board, amplifier: includes C108 thru C110 C112 C113 R106 thru R109 R111 thru R114 V101 V102						

See introduction to this section

APPENDIX

CODE LIST OF MANUFACTURERS (Sheet 1 of 2)

The following code numbers are from the Federal Supply Code for Manufacturers Cataloging Handbooks H4-1 (Name to Code) and H4-2 (Code to Name) and their latest supplements. The date of revision and the date of the supplements used appear at the bottom of each page. Alphabetical codes have been arbitrarily assigned to suppliers not appearing in the H4 Handbooks.

CODE NO.	MANUFACTURER	ADDRESS	CODE NO.	MANUFACTURER	ADDRESS	CODE NO.	MANUFACTURER	ADDRESS
00334	Humidrol Co.	Colton, Calif.	07137	Transistor Electronics Corp.	Minneapolis, Minn.	48420	Raytheon Thermometer and Instr. Co.	Philadelphia, Pa.
00335	Westrex Corp.	New York, N.Y.	07138	Westinghouse Electric Corp. Electronic Tube Div.	Elmira, N.Y.	49954	Praxair Company	Lexington, Mass.
00373	Garlock Packing Co., Electronic Products Div.	Camden, N.J.	07261	Avnet Corp.	Los Angeles, Calif.	54294	Shallcross Mfg. Co.	Selma, N.C.
00654	Aerovox Corp.	New Bedford, Mass.	07263	Fairchild Semiconductor Corp.	Mountain View, Calif.	55024	Simpson Electric Co.	Chicago, Ill.
00779	Amp, Inc.	Harrisburg, Pa.	07910	Continental Device Corp.	Hawthorne, Calif.	55932	Sonotone Corp.	Elmford, N.Y.
00781	Aircraft Radio Corp.	Boonton, N.J.	07933	Rheem Semiconductor Corp.	Mountain View, Calif.	55938	Sorenson & Co., Inc.	So. Norwalk, Conn.
00853	Sangamo Electric Company Ordill Division (Capacitors)	Marion, Ill.	07980	Boonton Radio Corp.	Boonton, N.J.	56137	Spaulding Fibre Co., Inc.	So. Tonawanda, N.Y.
00844	Go Engineering Co.	Los Angeles, Calif.	08145	U.S. Engineering Co.	Los Angeles, Calif.	56289	Sprague Electric Co.	North Adams, Mass.
00891	Carl E. Holmes Corp.	Los Angeles, Calif.	08358	Burgess Battery Co.	Niagara Falls, Ontario, Canada	59444	Telex, Inc.	St. Paul, Minn.
01121	Allen Bradley Co.	Milwaukee, Wis.	08717	Stoan Company	Burbank, Calif.	61775	Union Switch and Signal, Div. of Westinghouse Air Brake Co.	Swissvale, Pa.
01255	Liton Industries, Inc.	Beverly Hills, Calif.	08718	Cannon Electric Co.	Phoenix, Ariz.	62119	Universal Electric Co.	Owosso, Mich.
01281	Pacific Semiconductors, Inc.	Culver City, Calif.	08792	CBS Electronics Semiconductor Operations, Div. of C.B.S. Inc.	Lowell, Mass.	64953	Western Electric Co., Inc.	New York, N.Y.
01295	Texas Instruments, Inc. Transistor Products Div.	Dallas, Texas	09026	Babcock Relays, Inc.	Costa Mesa, Calif.	65092	Weston Inst. Div. of Dayton, Inc.	Newark, N.J.
01349	The Alliance Mfg. Co.	Alliance, Ohio	09134	Texas Capacitor Co.	Houston, Texas	66344	Wollensak Optical Co.	Rochester, N.Y.
01561	Chassi-Trak Corp.	Indianapolis, Ind.	09250	Electro Assemblies, Inc.	Chicago, Ill.	70274	Allen Mfg. Co.	Hartford, Conn.
01589	Pacific Relays, Inc.	Van Nuys, Calif.	09569	Mallory Battery Co. of Canada, Ltd.	Toronto, Ontario, Canada	70726	Allied Control Co., Inc.	New York, N.Y.
01730	Amerock Corp.	Rockford, Ill.	10411	TSL, Inc.	Niagara Falls, N.Y.	70845	Atlantic India Rubber Works, Inc.	Chicago, Ill.
01761	Pulse Engineering Co.	Santa Clara, Calif.	10446	Carborundum Co.	Berme, Ind.	70563	Amperite Co., Inc.	New York, N.Y.
02114	Ferroxcube Corp. of America	Saugerties, N.Y.	11236	CTS of Berns, Inc.	Chicago, Ill.	70903	Balden Mfg. Co.	Chicago, Ill.
02286	Cole Mfg. Co.	Palo Alto, Calif.	11337	Chicago Telephone of California, Inc.	Pasadena, Calif.	70998	Bird Electronic Corp.	Cleveland, Ohio
02660	Amphol-Borg Electronics Corp.	Chicago, Ill.	11711	General Instrument Corporation Semiconductor Division	Newark, N.J.	71002	Binkhad Radio Co.	New York, N.Y.
02735	Radio Corp. of America Semiconductor and Materials Div.	Somerville, N.J.	11717	Imperial Electronics, Inc.	Buena Park, Calif.	71041	Boston Gear Works Div. of Murray Co. of Texas	Quincy, Mass.
02771	Vaculine Co. of America, Inc.	Old Saybrook, Conn.	11870	Melabs, Inc.	Dover, N.H.	71218	Camco Resealer Corp.	Paramus, N.J.
02777	Hopkins Engineering Co.	San Fernando, Calif.	12697	Clarostat Mfg. Co.	Dover, N.H.	71313	Allen D. Cardwell Electronic Prod. Corp.	Plainville, Conn.
03508	G.E. Semiconductor Products Dept.	Syracuse, N.Y.	14655	Corneil Duplicator Elec. Corp.	So. Plainfield, N.J.	71400	Bussinesse & Edson Co.	St. Louis, Mo.
03785	Apex Machine & Tool Co.	Dayton, Ohio	15609	The Daven Co.	Livingston, N.J.	71450	CTS Corp.	Elkhart, Ind.
03777	Eldema Corp.	El Monte, Calif.	14758	Delco Radio Div. of G. M. Corp.	Kokomo, Ind.	71468	Cannon Electric Co.	Los Angeles, Calif.
03979	Transitron Electronic Corp.	Wakefield, Mass.	18873	F. I. DuPont and Co., Inc.	Wilmington, Del.	71471	Cinema Engineering Co.	Burbank, Calif.
03988	Pyrilum Resistor Co.	Morristown, N.J.	19315	Eclipse Pioneer, Div. of Bendix Aviation Corp.	Teterboro, N.J.	71482	C. P. Clare & Co.	Chicago, Ill.
03954	Air Marine Motors, Inc.	Los Angeles, Calif.	19500	Thomas A. Edison Industries, Div. of McGraw-Edison Co.	West Orange, N.J.	71528	Standard-Thomson Corp., Cliffford Mfg. Co. Div.	Waltham, Mass.
04009	Arrow, Hart and Hegeman Elect. Co.	Hartford, Conn.	17001	Electra Manufacturing Co.	Kansas City, Mo.	71590	Centralab Div. of Globe Union Inc.	Milwaukee, Wis.
04042	Elmecco Products Co.	New York, N.Y.	20183	Electronic Tube Corp.	Philadelphia, Pa.	71790	The Costinik Wire Co.	New York, N.Y.
04272	Mi-Q Division of Aerovox Myrtle Beach, S.C.	Myrtle Beach, S.C.	21520	Fanstel Metallurgical Corp.	No. Chicago, Ill.	71744	Chicago Miniature Lamp Works	Chicago, Ill.
04298	Elgin National Watch Co., Electronics Division	Burbank, Calif.	21335	The Fafnir Bearing Co.	New Britain, Conn.	71753	A. O. Smith Corp., Crowley Div.	West Orange, N.J.
04404	Dymac Division of Hewlett-Packard Co.	Palo Alto, Calif.	21944	Fed. Telephone and Radio Corp.	Clifton, N.J.	71785	Cinch Mfg. Corp.	Chicago, Ill.
04451	Sylvania Electric Prods., Inc. Electronic Tube Div.	Mountain View, Calif.	24444	General Electric Co.	Schenectady, N.Y.	71984	Dow Corning Corp.	Midland, Mich.
04713	Motorola, Inc. Semiconductor Prod. Div.	Phoenix, Arizona	24455	G.E. Lamp Division	West Concord, Mass.	72136	Electro Motive Mfg. Co., Inc.	Williamst, Conn.
04732	Filtrol Co., Inc. Western Division	Culver City, Calif.	24655	General Radio Co.	West Concord, Mass.	72354	John E. Fast & Co.	Chicago, Ill.
04773	Automatic Electric Co.	Norfolk, Va.	24642	Grobet File Co. of America, Inc.	Carlsbad, N.J.	72656	General Ceramics Corp.	Keasbey, N.J.
04870	P. M. Motor Co.	Chicago, Ill.	24992	Hamilton Watch Co.	Lawson, Pa.	72750	Girard-Hopkins	Oakland, Calif.
05004	Twentieth Century Plastics, Inc.	Los Angeles, Calif.	28480	Hewlett-Packard Co.	Palo Alto, Calif.	72765	Drake Mfg. Co.	Chicago, Ill.
05277	Westinghouse Electric Corp. Semi-Conductor Dept.	Youngwood, Pa.	33173	G.E. Receiving Tube Dept.	Owensboro, Ky.	72825	Hugh H. Eby Inc.	Philadelphia, Pa.
05593	Illumitron Engineering Co.	Sunnyvale, Calif.	35434	Leetron Inc.	Chicago, Ill.	72928	Gustman Co.	Chicago, Ill.
05624	Barber Colman Co.	Rockford, Ill.	37942	P. R. Mallory & Co., Inc.	Indianapolis, Ind.	72982	Erle Resistor Corp.	erie, Pa.
05729	Metropolitan Telecommunications Corp. Metro Cap. Div.	Brooklyn, N.Y.	39543	Mechanical Industries Prod. Co.	Akron, Ohio	73061	Hansen Mfg. Co., Inc.	Princeton, Ind.
05783	Stewart Engineering Co.	Santa Cruz, Calif.	40920	Miniature Precision Bearings, Inc.	Keene, N.H.	73138	Hellpott Div. of Beckman Instruments, Inc.	Fullerton, Calif.
04004	The Baskick Co.	Bridgeton, Conn.	42190	Muter Co.	Chicago, Ill.	73293	Hughes Products Division of Hughes Aircraft Co.	Newport Beach, Calif.
04555	Beede Electrical Instrument Co., Inc.	Tenasco, N.H.	43970	C. A. Norgren Co.	Englewood, Colo.	73445	Amperex Electronic Co., Div. of North American Philips Co., Inc.	Hamden, Conn.
04782	Torrington Mfg. Co., West Div.	Van Nuys, Calif.	44495	Ohmite Mfg. Co.	Skokie, Ill.	73559	Carling Electric, Inc.	Hartford, Conn.
07115	Corning Glass Works Electronic Components Dept.	Bradford, Pa.	47904	Polaroid Corp.	Cambridge, Mass.	73682	George K. Garreff Co., Inc.	Philadelphia, Pa.
07126	Digilran Co.	Pasadena, Calif.				73743	Fischer Special Mfg. Co.	Cincinnati, Ohio
						73793	The General Industrial Co.	Elyria, Ohio
						73905	Jennings Radio Mfg. Co.	San Jose, Calif.
						74455	J. H. Winn, and Sons	Winchester, Mass.

00015-19

Revised: 4 December 1961

From: F.S.C. Handbook Supplements
H4-1 Dated October 1961
H4-2 Dated November 1961

APPENDIX

CODE LIST OF MANUFACTURERS (Sheet 2 of 2)

CODE NO.	MANUFACTURER	ADDRESS	CODE NO.	MANUFACTURER	ADDRESS	CODE NO.	MANUFACTURER	ADDRESS
74861	Industrial Condenser Corp.	Chicago, Ill.	82877	Rotron Manufacturing Co., Inc.	Woodstock, N.Y.	93354	Method Mfg. Co.	Chicago, Ill.
74868	R.F. Products Division of Amphenol-Borg Electronics Corp.	Danbury, Conn.	82893	Vector Electronic Co.	Glendale, Calif.	93587	Westcoast Co.	Chicago, Ill.
74970	E. F. Johnson Co.	Waseca, Minn.	83058	Carr Fastener Co.	Cambridge, Mass.	94047	Huggins Laboratories	Sunnyvale, Calif.
75043	International Resistance Co.	Philadelphia, Pa.	83125	Pyramid Electric Co.	Darlington, S.C.	94095	Hi-Q Division of Aerovox	Olean, N.Y.
75173	Jones, Howe & Co., Division of Cinch Mfg. Corp.	Chicago, Ill.	83148	Electro-Cords Co.	Los Angeles, Calif.	94254	Thordarson-Majors Div. of Maguire Industries, Inc.	Los Angeles, Calif.
75378	Jans Knights Co.	Sandwich, Ill.	83184	Victory Engineering Corp.	Union, N.J.	94296	Solar Manufacturing Co.	Chicago, Ill.
75383	Kalka Electric Corporation	Mt. Vernon, N.Y.	83298	Bendis Corp., Red Bank Div.	Red Bank, N.J.	94320	Carlson Screw Co.	Chicago, Ill.
75578	Lens Electric Mfg. Co.	Chicago, Ill.	83330	Smith, Herman H., Inc.	Brooklyn, N.Y.	94341	Microvax Associates, Inc.	Burlington, Mass.
75715	Lithaflex Inc.	Des Plaines, Ill.	83501	Geyfert Wire and Cable Co., Div. of Amerace Corp.	Brookfield, Mass.	94391	Excel Transformer Co.	Oakland, Calif.
76005	Lor Mfg. Co.	Erie, Pa.	83594	Burroughs Corp.	Plainfield, N.J.	97539	Automatic and Precision Mfg. Co.	Yonkers, N.Y.
76210	C.W. Marwadal	San Francisco, Calif.	83777	Model Eng. and Mfg., Inc.	Huntington, Ind.	97966	CBS Electronics Div. of C.B.S., Inc.	Danvers, Mass.
76433	MacDonald Electronic Mfg. Corp.	Brooklyn, N.Y.	83821	Loyd Scruggs Co.	Felstus, Mo.	98141	Avet Brothers Inc.	Jamaica, N.Y.
76487	James Millen Mfg. Co., Inc.	Malden, Mass.	84171	Arco Electronics, Inc.	New York, N.Y.	98220	Francis L. Mosley	Pasadena, Calif.
76493	J. W. Miller Co.	Los Angeles, Calif.	84396	A. J. Glesener Co., Inc.	San Francisco, Calif.	98278	Microdot, Inc.	Pasadena, Calif.
76530	Monsard Mfg. Co.	San Leandro, Calif.	84411	Good All Electric Mfg. Co.	Bloomington, Ind.	98291	Selvector Corp.	Mamaronck, N.Y.
76545	Mueller Electric Co.	Cleveland, Ohio	84470	Sarkis Tarlan, Inc.	Bloomington, Ind.	98405	Carad Corp.	Redwood City, Calif.
76854	OK Manufacturing Co.	Chicago, Ill.	85454	Bonton Molding Company	Bonton, N.J.	98734	Palo Alto Engineering Co.	Palo Alto, Calif.
77068	Bendix Pacific Division of Bendix Corp.	No. Hollywood, Calif.	85474	R. M. Bracamonte & Co.	San Francisco, Calif.	98821	North Hills Electric Co.	Mineola, N.Y.
77221	Phacotron Instrument and Electronic Co.	South Pasadena, Calif.	85640	Kolled Kerds, Inc.	New Haven, Conn.	98825	Clevite Transistor Prod. Div. of Clevite Corp.	Waltham, Mass.
77342	Potter and Brumfield, Div. of American Machine and Foundry	Princeton, Ind.	85911	Seamless Rubber Co.	Chicago, Ill.	98978	International Electronic Research Corp.	Burbank, Calif.
77430	Radio Condenser Co.	Camden, N.J.	86684	Radio Corp. of America, RCA	Harrison, N.J.	99109	Columbia Technical Corp.	New York, N.Y.
77438	Radio Resistor Co., Inc.	Brooklyn, N.Y.	87216	Philco Corp. (Lansdale Division)	Lansdale, Pa.	99132	Varian Associates	Palo Alto, Calif.
77744	Resistance Products Co.	Harrisburg, Pa.	87473	Western Fibrous Glass Products Co.	San Francisco, Calif.	99515	Marshall Industries, Electron Products Division	Pasadena, Calif.
78283	Signal Indicator Corp.	New York, N.Y.	88140	Cutler-Hammer, Inc.	Lincoln, Ill.	99707	Control Switch Division, Controls Co. of America	San Diego, Calif.
78471	Tilley Mfg. Co.	San Francisco, Calif.	89473	General Electric Distributing Corp.	Schenectady, N.Y.	99800	Dalevan Electronic Corp.	East Aurora, N.Y.
78488	Stackpole Carbon Co.	St. Marys, Pa.	89436	Carter Parts Div. of Economy Goods Div.	Chicago, Ill.	99848	Wilco Corporation	Indianapolis, Ind.
78553	Timmerman Products, Inc.	Cleveland, Ohio	89465	United Transformer Co.	Chicago, Ill.	99914	Renbrant, Inc.	Boston, Mass.
78790	Transformer Engineers	Pasadena, Calif.	91079	U.S. Rubber Co., Mechanical Goods Div.	Pasaic, N.J.	99942	Hoffman Semiconductor Div. of Hoffman Electronics Corp.	Everett, Wash.
78947	Ucinit Co.	Newtownville, Mass.	90970	Bearing Engineering Co.	San Francisco, Calif.	99957	Technology Instrument Corp. of Calif.	Newbury Park, Calif.
79142	Veeder Root, Inc.	Hartford, Conn.	91240	Connor Spring Mfg. Co.	San Francisco, Calif.			
79251	Wanco Mfg. Co.	Chicago, Ill.	91418	Radio Materials Co.	Chicago, Ill.			
79727	Continental-Wirt Electronics Corp.	Philadelphia, Pa.	91506	Auspar Brothers, Inc.	Attleboro, Mass.			
79963	Zierick Mfg. Corp.	New Rochelle, N.Y.	91637	Dale Electronics, Inc.	Columbus, Nebr.			
80031	Mexco Division of Sessions Clock Co.	Morrisstown, N.J.	91642	Elco Corp.	Philadelphia, Pa.			
80130	Times Facsimile Corp.	New York, N.Y.	91737	Gremer Mfg. Co., Inc.	Wakfield, Mass.			
80131	Electronic Industries Association Any brand tube meeting EIA standards	Washington, D.C.	91827	K.F. Development Co.	Redwood City, Calif.			
80207	Unimax Switch, Div. of W. L. Mason Corp.	Wallingford, Conn.	91921	Minneapolis-Honeywell Regulator Co. Micro-Switch Division	Freeport, Ill.			
80248	Oxford Electric Corp.	Chicago, Ill.	92196	Universal Metal Products, Inc.	Bassett Pointe, Calif.			
80294	Bourn Laboratories, Inc.	Riverside, Calif.	93332	Sylvania Electric Prod. Inc., Semiconductor Div.	Woburn, Mass.			
80411	Acro Div. of Robertshaw Fulton Controls Co.	Columbus 16, Ohio	93349	Robbins and Myers, Inc.	New York, N.Y.			
80484	All Star Products Inc.	Defiance, Ohio	93410	Stevens Mfg. Co., Inc.	Manassah, Ohio			
80583	Hammerlund Co., Inc.	New York, N.Y.	93983	Insuline-Van Norman Ind., Inc. Electronic Division	Manchester, N.H.			
80640	Stevens, Arnold, Co., Inc.	Boston, Mass.	94144	Raytheon Mfg. Co., Industrial Components Div., Receiving Tube Operation	Quincy, Mass.			
81030	International Instruments, Inc.	New Haven, Conn.	94145	Raytheon Mfg. Co., Semiconductor Division	Newton, Mass.			
81415	Wilkor Products, Inc.	Cleveland, Ohio	94148	Scientific Radio Products, Inc.	Loveland, Colo.			
81453	Raytheon Mfg. Co., Industrial Components Div., Indust. Tube Operation	Newton, Mass.	94154	Tung-Sol Electric, Inc.	Newark, N.J.			
81483	International Rectifier Corp.	El Segundo, Calif.	94197	Curtiss-Wright Corp., Electronics Div.	East Paterson, N.J.			
81880	Barry Controls, Inc.	Watertown, Mass.	94682	Worcester Pressed Aluminum Corp.	Worcester, Mass.			
82042	Carler Parts Co.	Skokie, Ill.	95236	Allies Products Corp.	Miami, Fla.			
82142	Jaffers Electronics Division of Speer Carbon Co.	Du Bois, Pa.	95238	Continental Connector Corp.	Woodside, N.Y.			
82170	Allen B. DuMont Labs., Inc.	Clifton, N.J.	95243	Leecraft Mfg. Co., Inc.	New York, N.Y.			
82209	Maguire Industries, Inc.	Greenwich, Conn.	95264	Lercro Electronic, Inc.	Burbank, Calif.			
82219	Sylvania Electric Prod. Inc., Electronic Tube Div.	Emporium, Pa.	95265	National Coil Co.	Sheridan, Wyo.			
82374	Astron Co.	East Newark, N.J.	95275	Vitramon, Inc.	Bridgeport, Conn.			
82389	Switchcraft, Inc.	Chicago, Ill.						
82447	Metals and Controls, Inc., Div. of Texas Instruments, Inc.	Spencer, Ind.						
82866	Research Products Corp.	Madison, Wis.						

THE FOLLOWING H.P. VENDORS HAVE NO NUMBER ASSIGNED IN THE LATEST SUPPLEMENT TO THE FEDERAL SUPPLY CODE FOR MANUFACTURERS

00001	Malco Tool and Die	Los Angeles, Calif.
00002	Telefunks (c/o American Elite)	New York, N.Y.
00003	Winchester Electronics, Inc.	Santa Monica, Calif.
00004	Western Coil Div. of Automatic Ind., Inc.	Redwood City, Calif.
00005	Nahm-Bros. Spring Co.	San Leandro, Calif.
00006	Ty-Car Mfg. Co., Inc.	Holliston, Mass.
00007	Sures Instruments, Inc.	Ypsilanti, Ky.
00008	Metals and Control Div. of Tower Mfg. Corp.	Providence, R.I.
00009	Webster Electronics Co. Inc.	Washington, D.C.
00010	Spruce Pine Mica Co.	New York, N.Y.
00011	Midland Mfg. Co. Inc.	Springe, N.C.
00012	Willow Leather Products Corp.	Newark, N.J.
00013	A British Radio Electronics Ltd.	Newark, N.J.
00014	Precision Instrument Component Co.	Van Nuys, Calif.
00015	C Computer Diode Corp.	Los Angeles, Calif.
00016	D General Transistor	Los Angeles, Calif.
00017	A. Williams Manufacturing Co.	San Jose, Calif.
00018	Carmichael Corrugated Specialties	Richmond, Calif.
00019	Goshen Die Cutting Service	Goshen, Ind.

From: F.S.C. Handbook Supplements
H4-1 Dated October 1961
H4-2 Dated November 1961

00015-19
Revised: 6 December 1961

hp MANUAL CHANGES

MODEL 413A

DC NULL VOLTMETER

Manual Serial Prefixed: 139-
Manual Printed: 2/62

To adapt this manual to instruments with other serial prefixes check for errata below, and make changes shown in tables.

Instrument Serial Prefix	Make Manual Changes	Instrument Serial Prefix	Make Manual Changes
139-	ERRATA		
315-	1. ERRATA		
ALL	ERRATA		

ERRATA

Figure 5-16, Power Supply schematic diagram,
Center-arm of R8 (ZERO) should be connected to R125, 126 and S101H.

F1 (115V): Change to fuse, cartridge, 0.6 amp, slo-blo (for 115V operation),
hp Stock No. 2110-0016

F1 (230V): Change to fuse, cartridge, 0.4 amp, slo-blo (for 230V operation),
hp Stock No. 2110-0019

Paragraph 5-16, DEMODULATOR

j) should read, Replace DS103 and remove DS104

p) Turn the 413A off and replace DS104 and V102.

Paragraph 5-35, Step a

Change to, 413A or 412A

CHANGE #1

Table 6-1, Replaceable Parts

Change T1 to hp Stock No. 9100-0238

Figure 5-16. Power Supply

Change schematic diagram as shown

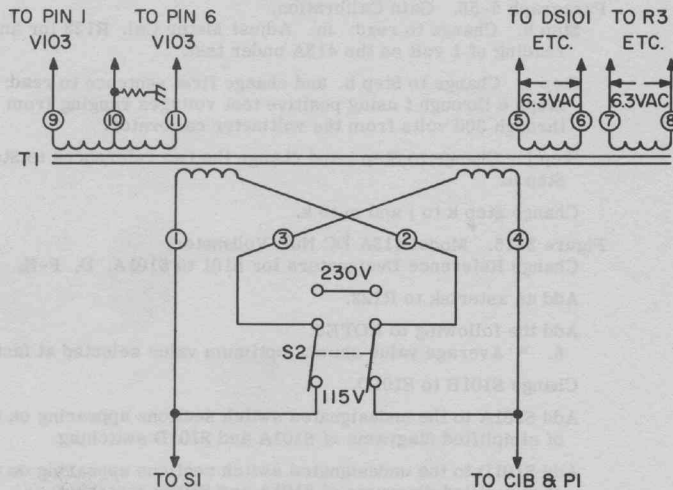

ERRATA

Table 1-1, SPECIFICATIONS.

Noise Specification should read, "Noise: Less than 2 mv (RMS)
on any range."

3/31/64 R

Supplement A for
413A-900

Instrument Serial Prefix

Make Manual Changes

Instrument Serial Prefix

Make Manual Changes

139-	ERRATA		
315-	1, ERRATA		
ALL	ERRATA		

ERRATA	<p>Figure 2-1. 230 Volt Operation, Change S1 to S2.</p> <p>Figure 4-1. Model 413A Block Diagram, Add arrowhead to arc on A103 to indicate clockwise rotation of the light interrupter.</p> <p>Paragraph 5-12. Chopper Assembly, Step c. Delete last sentence.</p> <p>Figure 5-1. A103, Chopper Assembly, Change DS104-413AR to DS101-413AR. Change DS103-413AR to DS102-413AR. Change DS101-413AR to DS104-413AR. Change DS102-413AR to DS103-413AR.</p> <p>Paragraph 5-16. Demodulator, Step d should read: Connect a 1 μf capacitor across the input terminals of an ohmmeter.</p> <p>Paragraph 5-33. Hum Balance, Step d. First sentence should read: Adjust Hum Bal. (R3) for minimum (less than 5 millivolts peak to peak) 10 cps signal as seen on oscilloscope.</p> <p>Paragraph 5-35. Amplifier Gain Calibration and Meter Calibration, Add the following sentence to Step f: Set voltmeter calibrator range switch to 1.0 volt.</p> <p>Figure 5-8. Amplifier Calibration Test Setup, Add (System Indicator) under ϕ 413A DC Null Voltmeter adjacent to the 413A under test.</p> <p>Paragraph 5-38. Gain Calibration, Step h. Change to read: m. Adjust Meter Cal. R123 for an end-scale reading of 1 volt on the 413A under test. Step i. Change to Step h. and change first sentence to read: Repeat Steps c through f using positive test voltages ranging from 0.001 volt through 300 volts from the voltmeter calibrator. Step j. Change to Step i and change the two references to Step i to read Step h. Change Step k to j and m to k.</p> <p>Figure 5-15. Model 413A DC Null Voltmeter, Change Reference Designators for S101 to S101A, D, F-H. Add an asterisk to R122. Add the following to NOTES: 6. * Average value shown, optimum value selected at factory. Change S101B to S101D. Add S101A to the undesignated switch sections appearing on the left side of simplified diagrams of S101A and S101D switching. Add S101D to the undesignated switch sections appearing on the right side of simplified diagrams of S101A and S101D switching.</p> <p>Table 6-1. Reference Designation Index, Change CR1 to ϕ Stock No. 1902-0206; Diode, breakdown; Mfr. 04713.</p>		
--------	---	--	--



WARRANTY

All our products are warranted against defects in materials and workmanship for one year from the date of shipment. Our obligation is limited to repairing or replacing products (except tubes) which prove to be defective during the warranty period. We are not liable for consequential damages.

For assistance of any kind, including help with instruments under warranty, contact your authorized  Sales Representative for instructions. Give full details of the difficulty and include the instrument model and serial numbers. Service data or shipping instructions will be promptly sent to you. There will be no charge for repair of instruments under warranty, *except transportation charges*. Estimates of charges for non-warranty or other service work will always be supplied, if requested, before work begins.

CLAIM FOR DAMAGE IN SHIPMENT

Your instrument should be inspected and tested as soon as it is received. The instrument is insured for safe delivery. If the instrument is damaged in any way or fails to operate properly, file a claim with the carrier or, if insured separately, with the insurance company.

SHIPPING

On receipt of shipping instructions, forward the instrument prepaid to the destination indicated. You may use the original shipping carton or any strong container. Wrap the instrument in heavy paper or a plastic bag and surround it with three or four inches of shock-absorbing material to cushion it firmly and prevent movement inside the container.

GENERAL

Your authorized  Sales Representative is ready to assist you in any situation, and you are always welcome to get directly in touch with Hewlett-Packard service departments:

CUSTOMER SERVICE

Hewlett-Packard Company
395 Page Mill Road
Palo Alto, California, U.S.A.
Telephone: (415) 326-1755
TWX No. PAL AL 117-U
Cable: "HEWPACK"

OR (In Western Europe)

Hewlett-Packard S.A.
54-54bis Route Des Acacias
Geneva, Switzerland
Telephone: (022) 42. 81. 50
Cable: "HEWPACKSA"





413A-900

PRINTED IN U.S.A.

Free Manuals Download Website

<http://myh66.com>

<http://usermanuals.us>

<http://www.somanuals.com>

<http://www.4manuals.cc>

<http://www.manual-lib.com>

<http://www.404manual.com>

<http://www.luxmanual.com>

<http://aubethermostatmanual.com>

Golf course search by state

<http://golfingnear.com>

Email search by domain

<http://emailbydomain.com>

Auto manuals search

<http://auto.somanuals.com>

TV manuals search

<http://tv.somanuals.com>