

OPERATOR'S MANUAL & PARTS LIST

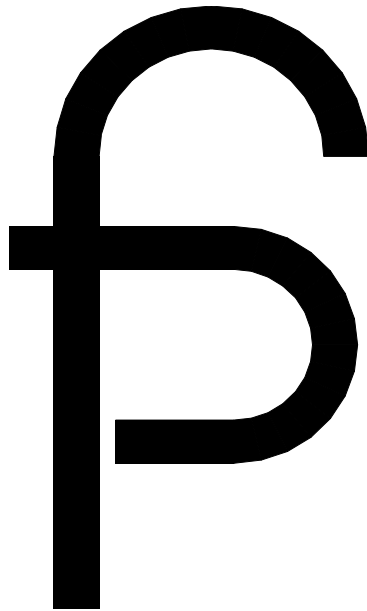

AERA-vator MODEL AE40L

FIRST PRODUCTS INC.

164 Oakridge Church Rd.

Tifton, Georgia 31794 U.S.A.

Phone (229) 382-4768

1-800-363-8780

Fax (229) 382-0506

Web: www.1stproducts.com Email: Sales@1stproducts.com

Ser. 352 thru ___
Printed in U.S.A.
PBREV0104

INTRODUCTION

Thank you for purchasing an AREA-vator. This piece of equipment has been carefully engineered and manufactured to provide years of reliable service.

The AERA-vator is one of the most unique and versatile pieces of equipment on the market today. It is designed for the practices of turf cultivation, seed bed preparation, and bare soil conditioning in your toughest soils.

We recommend that you carefully read the owners and operators manual prior to operation. Also ensure that all future operators read this manual and become fully trained before allowing them to use or maintain this equipment. Time spent becoming acquainted with the safe operation, performance, and maintenance of the AERA-vator will add longer life and greater satisfaction to your new purchase.

This machine is designed with safety in mind. However, if the machine is handled carelessly and not as instructed it can be a dangerous piece of equipment. Observe all safety information in this manual and decals on the equipment. You the operator are responsible when operating this equipment.

The illustrations and data used in the manual were current at time of printing. The manufacturer reserves the right to make changes or add improvements to its products at any time without incurring any obligation to make such changes to products manufactured previously.

REMEMBER SAFETY IS ALWAYS FIRST !

ATTENTION:

- **Read and understand the instructions and warnings carefully before using this machine.**
- **Read the warranty located on page 16. Fill in the required information on the warranty registration provided and return to the address on the front of this manual. The warranty registration must be returned to validate warranty.**

TABLE OF CONTENTS

SAFETY SYMBOLS	3
SAFETY DECALS	4
OPERATION SAFETY	5
OPERATOR INSTRUCTIONS	6
UNDERSTANDING HOW THE SWING HITCH OPERATES (PRIOR TO HITCHING TO TRACTOR)	7
CORRECTLY ADJUSTING THE HITCH TO THE TRACTOR	7
PRE-OPERATION CHECK LIST	8
MAINTENANCE SAFETY	9
OPERATOR MAINTENANCE.....	10
AE40L SERVICE INSTRUCTIONS	11
ROTOR SHAFT.....	11
I. Removal & Disassembly (Clean the machine thoroughly with a pressure washer).....	11
II. Reassembly and Installation	12
TINE REPLACEMENT.....	14
SEEDER MAINTENANCE.....	14
SEEDER CALIBRATION	15
I. GENERAL OBSERVATIONS	15
II. CALIBRATION PROCEDURE.....	16
WARRANTY INFORMATION	17
MAIN FRAME ASSEMBLY	17
DRIVE TRAIN COMPONENTS.....	18
LIFT AND TRAIL HITCH GROUP.....	19
ROTOR ASSEMBLY	20
DRIVE LINE COMPONENTS	21
SMOOTHING ROLLER.....	22
GROOMING RAKE & BRUSH.....	23
40I SEEDER MOUNTING	24
42" SEEDER DRIVE	25
42" SEEDER PARTS LIST	26
42" SEEDER	27
NOTES	29
SPECIFICATIONS	30

SAFETY SYMBOLS

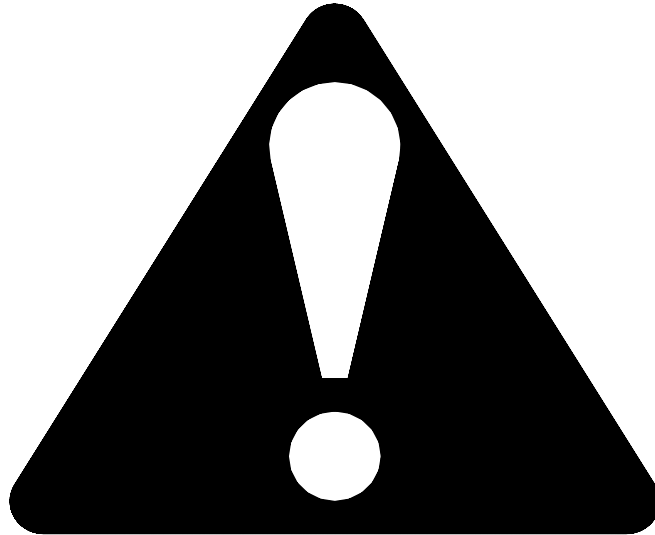

This is a standard safety alert symbol meaning **ATTENTION ! BECOME ALERT ! YOUR SAFETY IS INVOLVED !**

 **CAUTION** Indicates hazardous situation, injury may occur, used to alert against carelessness.

 **WARNING** Indicates potentially hazardous situation. Death or serious injury may occur if proper procedures are not followed.

 **DANGER** Indicates most hazardous situation. Death or serious injury will occur if proper procedures are not followed.

SAFETY DECALS

▲ WARNING

- 1.) READ OPERATORS MANUAL AND LEARN TO OPERATE THIS MACHINE SAFELY.
- 2.) DO NOT ENGAGE P.T.O. UNTIL UNIT IS LOWERED.
- 3.) DO NOT LIFT WITH P.T.O. ENGAGED.
- 4.) KEEP PEOPLE CLEAR WHEN OPERATING OR LIFTING FOR TRANSPORT.
- 5.) BEFORE LEAVING THE OPERATOR'S POSITION TO ADJUST, LUBRICATE, CLEAN, OR UNCLG THE MACHINE, STOP ENGINE AND SET BRAKE.
- 6.) WAIT FOR ALL MOVEMENT TO STOP BEFORE SERVICING THE MACHINE.
- 7.) INSTALL AND SECURE ALL GAURDS BEFORE OPERATING.
- 8.) KEEP HANDS, FEET AND CLOTHING AWAY FROM POWER DRIVEN PARTS.

AE50-074

Part No. AE50-074

Part No. AE50-075

▲ CAUTION



FRAME PINCH POINT
HAZARD KEEP AWAY

NOTE: REPLACE ANY SAFETY DECALS WHICH ARE NOT LEGIBLE

▲ DANGER



SHIELD MISSING
DO NOT OPERATE

Part No. AE50-114

Located under shield

▲ DANGER



ROTATING DRIVELINE
CONTACT CAN CAUSE DEATH
KEEP AWAY
DO NOT OPERATE WITHOUT

- ALL DRIVELINE GUARDS,TRACTOR AND EQUIPMENT SHIELDS IN PLACE
- DRIVELINES SECURELY ATTACHED AT BOTH ENDS
- DRIVELINES GUARDS THAT TURN PREELY ON DRIVELINE

Part No. GP55-007

▲ DANGER



GUARD MISSING
DO NOT OPERATE

▲ DANGER



GUARD MISSING
DO NOT OPERATE

▲ DANGER

GP55-004

Refer to Drive Line Owners Manual for location of Danger Decals (Drive Line Not Shown)

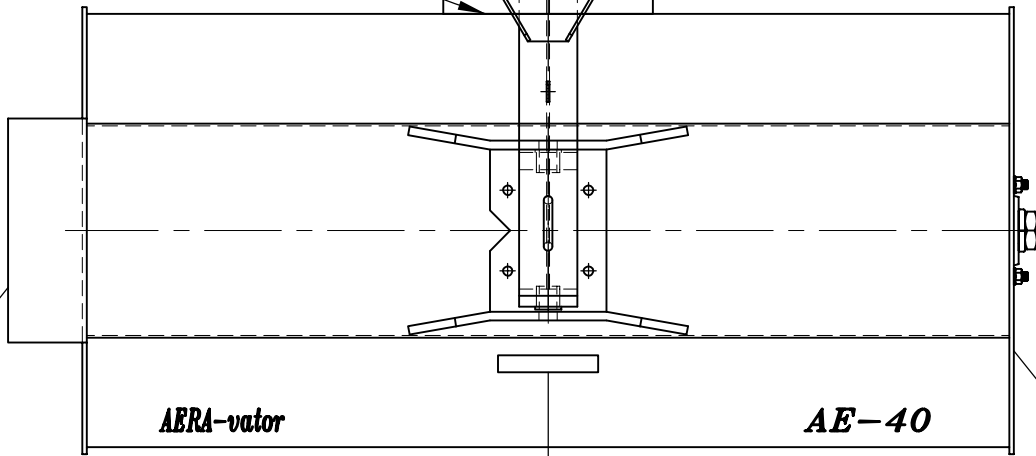

ABRA-vator

AE-40

▲ WARNING



*TO PREVENT A THROWN OBJECT HAZARD, DO NOT ENGAGE PTO IN LIFTED POSITION.
*TO PREVENT A ROLL OVER HAZARD DO NOT LIFT THE UNIT WHILE SIDEWAYS ON SLOPES ABOVE 5 DEGREES.



AE50-076

Part No. AE50-076

▲ WARNING



SWINGING FRAME HAZARD

- 1.) STAND CLEAR 10FT. WHEN LIFTING MACHINE.
- 2.) DO NOT ALLOW RIDERS ON IMPLEMENT.

AE50-113

Part No. AE50-113

Located on both ends of machine.

ROLLER ATTACHMENT
NOT SHOWN

OPERATION SAFETY

- **Your Safety Is Always First!** Familiarize yourself with the safety symbols and decals on pages 3 and 4.
- All operators should **read and understand the following sections of this manual** prior to adjusting, maintaining, hitching to, or operating the AERA-vator: **OPERATION SAFETY, OPERATOR INSTRUCTIONS, PRE-OPERATION CHECKS, MAINTENANCE CHECKS, MAINTENANCE SAFETY, OPERATOR MAINTENANCE.**
- In addition, remove and read the drive line safety and maintenance manual taped to the drive line shield. After reading the drive line manual, place it inside this manual for reference.
- For the safety and instruction of all operators, keep this manual stored on the AERA-vator at all times.
- Never attempt to adjust, maintain, or remove debris from any moving part of this machine while it is attached to a tractor or other power source with the engine running.
- After operating, always disengage the power take off and switch the engine off prior to dismounting from the tractor or other power source and approaching the unit.
- Prior to starting, always inspect operating area for any hazards such as large rocks, steep slopes, low tree branches or wires. Flag objects difficult to see such as irrigation heads and water meters.
- Instruct all people in the work area to stay clear of the unit.
- Perform all pre-operation checks (*page 8*) prior to start up.
- Never engage the power take off while the rotors are off the ground. Always disengage the power take off before lifting the unit. High-speed rotors create a flying object hazard when they are lowered to the ground.

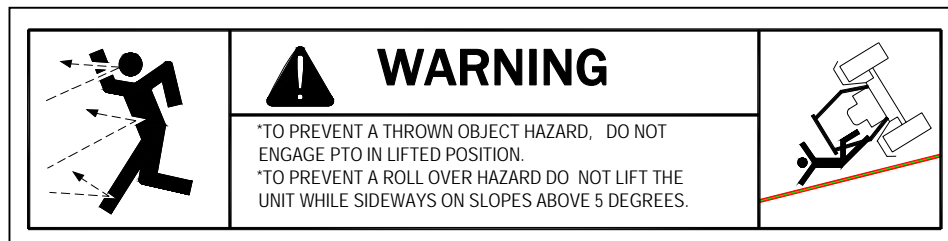

Figure 1. *Tractor Roll Over/Thrown Object Warning*

- Consult your tractor Operator's Manual regarding operation on slopes. Do not lift the unit while the tractor is moving (or parked) sideways on slopes above 5°. The swing hitch may allow the unit to swing to the downhill side and cause the tractor to roll over. On slopes from 5° to 15° always aim the tractor uphill before lifting the unit. We do not recommend the unit being used on slopes above 15°.
- Use extreme care and maintain moderate ground speed when transporting or operating on slopes, over rough surfaces, or close to trees ditches and fences.
- Only operate during daylight hours or with good artificial light.
- The AERA-vator is not equipped for highway use. Be careful of traffic when operating near or crossing roadways.

OPERATOR INSTRUCTIONS

- The AE-40L AERA-vator is designed to attach to a tractor with a category one three point hitch, 540 PTO, and a minimum of 12 horsepower. However, a larger tractor may be required for increased lifting capacity. Check the tractor owner and operator's manual for lift capacity. The weight of the AE-40L is 570 lbs.
- Before hitching to the AERA-vator familiarize yourself with all of the tractor's control functions. Be prepared to stop the tractor movement, PTO operation, and the engine quickly in an emergency.

UNDERSTANDING HOW THE SWING HITCH OPERATES (PRIOR TO HITCHING TO TRACTOR)

With the swing stand lowered and the swing mast rearward to disengage the swing lock, grasp the hitch pins and rotate the "A" frame to simulate operation in a sharp turn. Release the hitch pins and slowly pull the swing mast forward as it would be pulled by the top link during lifting. Notice how one mast chain tightens causing the "A" frame and unit to realign and the spring on the lock link is compressed to make the swing lock engage upon alignment. Now push the swing mast rearward against the lock link tab to disengage the swing lock and loosen the chains to allow sharp turns again. This demonstrates how the top link of the tractor lift system switches the AERA-vator between the trail and lift modes.

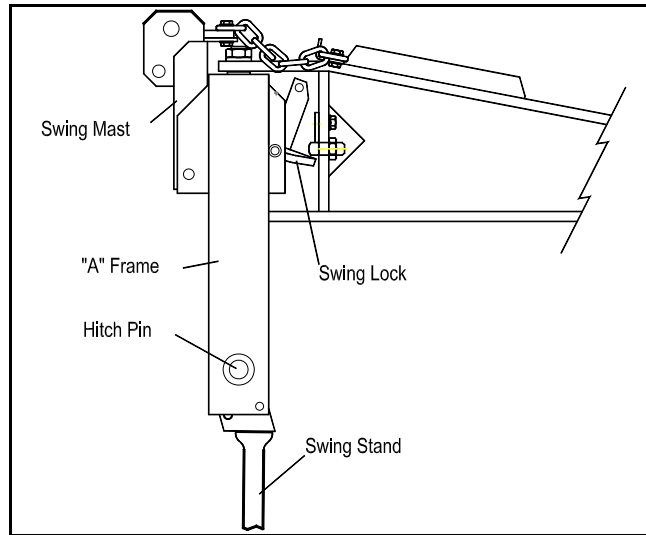

Figure 2. *Swing Hitch Operation*

CORRECTLY ADJUSTING THE HITCH TO THE TRACTOR

A category 1 hitch tractor is required with the lower links stabilized. With the AERA-vator swing stand lowered connect the lower lift links to the "A" Frame and top link to the swing mast. Push the lift control lever on the tractor to the completely lowered position. Lengthen the adjustable top link until the swing mast closes tight against the "A" Frame and the AERA-vator swing stand is lifted 1/8 to 1/4 inch off the ground. This causes the combined weight of the AERA-vator and the tractor hitch components to be transferred to the tines. This extended top link also causes the

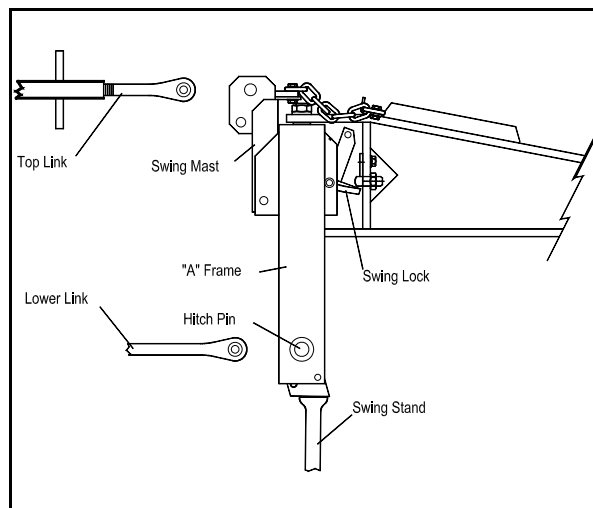

Figure 3. *Hitch Adjustment*

AERA-vator to tilt backwards when lifting allowing gravity to assist the swing chains in aligning the unit with the tractor. **DO NOT ADD ADDITIONAL WEIGHT TO THE AERA-vator OR APPLY DOWN PRESSURE TO THE TRACTOR LIFT LINKS DURING OPERATION.**

- The geometry of tractor lift linkages varies, and a trial run over uneven ground is recommended. Ideally the swing lock will not engage when aerating over the crown of a hill and the tractor hitch is always free to float upward at all times. The tines should clear curbs etc., when lifted.
- When lowering for operation, lower slowly until the tines touch the ground. Then swiftly push the lift control lever on the tractor to the completely lowered position to instantly unlock the hitch. This is especially true when lowering the unit in a sharp turn. Failure to do this may cause the swing hitch not to disengage, resulting in damage to the machine and/or turf damage. In the event the unit should fail to unlock for trail mode, stop the tractor and repeat the lowering procedure.

DO NOT TURN THE TRACTOR WITH THE AERA-vator IN THE GROUND AND THE SWING LOCK ENGAGED. DAMAGE TO EQUIPMENT MAY OCCUR!

- When operating diagonally downhill or transversely (sideways) on a hillside slope above 5° the mast chains will not swing the unit uphill to center and lock on the tractor when the unit is lifted. Occasionally the unit will swing farther to the downhill side of the tractor creating the hazard of tractor roll over. If the tractor ever seems unstable, immediately lower the hitch and steer the tractor uphill or on a more level surface where it will center and lock when lifted.
- Do not back the unit up with the AERA-vator touching the ground. Always disengage the PTO, raise the unit, back to desired location and then lower the machine and engage the PTO.
- The operating ground speed of the tractor will depend on the amount of soil agitation required. Slower tractor ground speed (lower gears) will be used for renovating in extremely hard dry ground. Faster tractor ground speeds (higher gears) will be used for aeration work in normal conditions. To reduce the amount of soil agitation simply reduce the engine RPM. Three to four miles per hour is the most common speed range.

PRE-OPERATION CHECK LIST

(With the AERA-vator lowered and the tractor engine switched off...)

- Be sure that the implement is hitched to the tractor properly with all pins in place.
- Pin the swing stand in the up position.
- Be sure the driveline is correctly assembled. (The end stenciled as the tractor end is connected to the tractor and not to the AERA-vator). Check to see that the end yokes are



locked to the tractor PTO and gearbox shafts. Drive shields must turn freely on the drive-line.

- See that all shields are correctly installed.
- Remove any debris caught in the rotors.
- Check gearbox oil level before first operation and every 200 hours of operation thereafter. (Refer to operator maintenance section.)

MAINTENANCE SAFETY

- Never attempt to clean, adjust, lubricate or perform any maintenance on the AERA-vator while it is attached to the tractor or any other power source with the engine running.
- Read and understand all safety decals prior to performing any maintenance. Replace any safety decals that are not legible.
- Never attempt to clean, adjust, lubricate or perform any maintenance on the AERA-vator while it is attached to the tractor in the raised position unless safety blocks are inserted under the frame.
- When not attached to the tractor, always use the lifting hook to hoist the machine for maintenance. (See *Figure 4*). Use extreme caution when using lifting hook because center of gravity is affected by additional attachments and the unit may shift rearward.
- When installing tines, performing any rotor shaft service, or removing debris from the rotors, ensure that the rotor shaft does not rotate because a serious pinch injury could occur.

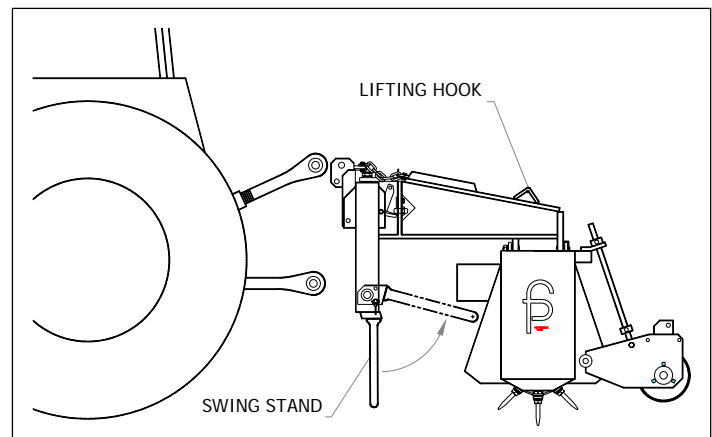

Figure 4. *Swing Stand/Lifting Hook*

OPERATOR MAINTENANCE

- Check gearbox oil level before first operation and every 200 hours of operation thereafter. With frame level, remove oil plug on top side of gear box using 5/16" x 6" allen wrench through access hole in frame. Use a piece of 1/16" dia. wire for checking fluid level. Push wire into hole in gearbox until it hits the bottom. Pull out and measure the amount of oil left on wire. There should be approx. 1-3/4" to 2" of oil on wire. If required, add 90w-gear oil through plug in top of box until correct amount appears on wire. Replace top plug securely.
- Grease driveline parts after the number hours use as shown in the following chart.

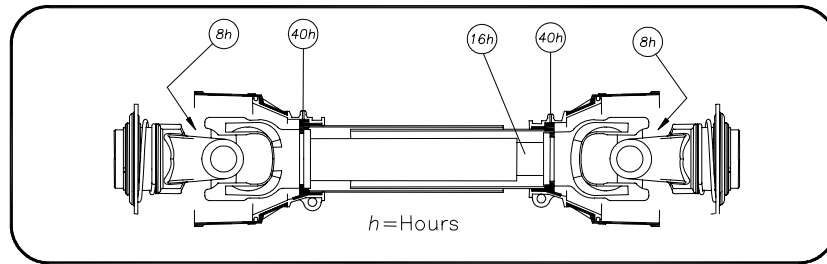

Figure 5 Drive Line Lube Chart

- The hitch flex joints at the top of the “A” frame and above the gearbox (see page 18) should be lubricated before first operation and weekly thereafter.
- After the first two hours of operation tighten all tines to 210-ft. lbs. Check for loose tines daily.
- When replacing lost or worn tines use a 15/16" extra deep socket (Socket is available through our repair parts. Order # AE60T003) and torque to 210 ft. lbs.
- **CHECK BELT TENSION** every 4 hrs. of operation for the first 12 hrs. and every 100 hrs. thereafter. Also, tighten belts if shaft hesitation is noticed during operation. Over tightening belts may cause damage to the machine. Be sure to re-install belt shield after servicing.
- Use the applicable parts break down illustration pp.16-22 for maintenance removal, and assembly instructions.
- The AERA-vator shaft and rotor bearings are sealed and permanently lubricated requiring no routine maintenance.

AE40L SERVICE INSTRUCTIONS

ROTOR SHAFT

I. Removal & Disassembly (Clean the machine thoroughly with a pressure washer)

A. Removal of Rotor Shaft Assembly from Main Frame.

(This may require an overhead lift. For safety reasons, only lift the Aera-vator approximately two inches above the work surface).

1. Remove belt cover and drive belts.
2. Remove skid shoe.
3. Remove 3/8" carriage bolts holding end rotor shaft bearings (see Figure 6).
4. Move frame slightly to right and lift off of rotor shaft assembly. Refer to Drive Train Components for identifying listed components not shown, pg. 17

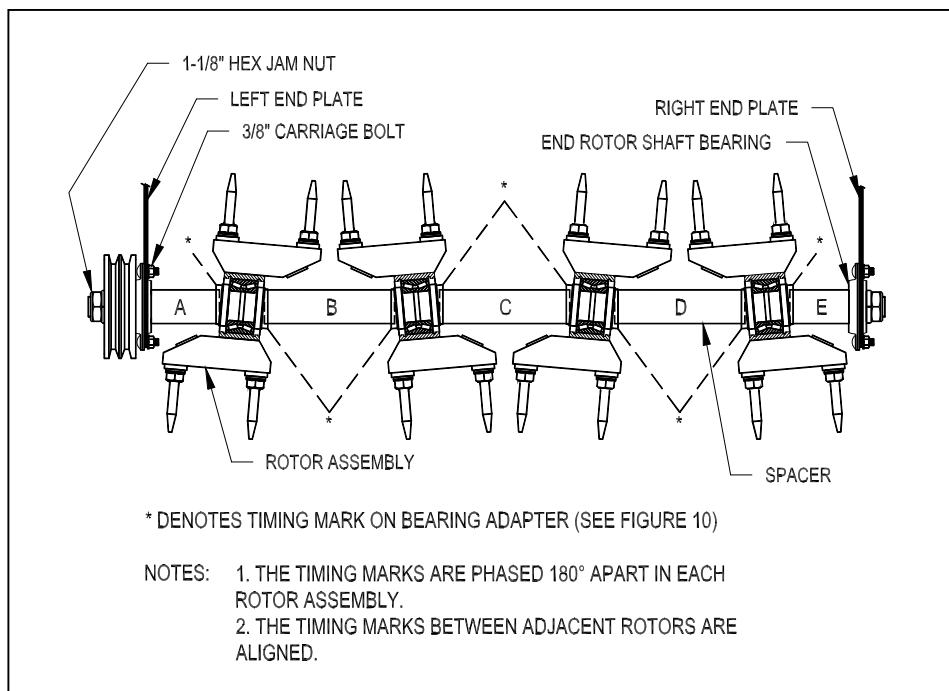

Figure 6. Rotor Shaft Assembly

B. Disassembly of Rotor Shaft Assembly

1. Remove the 1-1/8" hex jam nut from the shaft nearest to the damaged rotor (see Figure 6).
2. Only remove the rotors and spacers as required to reach the damaged component and wipe the shaft clean before each rotor is removed. The rotor bearings have individual cones on each side that separate slightly before seal resistance is felt. It is important to keep the cones pushed tightly together to keep dirt from entering the bearing between the cones.



IF THE ROTOR ASSEMBLIES DO NOT SLIP FREELY OFF THE ROTOR SHAFT DO NOT APPLY FORCE AGAINST THE ROTORS OR ROTOR TEETH. USE A BLUNT PUNCH OR BAR AGAINST THE THICK FACE OF THE INSIDE BEARING ADAPTER TO DRIVE THE ROTORS ALONG THE SHAFT. OTHERWISE THE SEAL IN THE TAPERED ROLLER BEARING WILL BE DESTROYED AND IT IS NOT REPLACEABLE (SEE FIGURE 7).

C. Rotor Disassembly.

1. With a pry bar remove the external seals (see Figure 8) on both sides. Generally, seals are damaged and are not reused.
2. Remove the internal snap rings on both sides.
3. With the Rotor sitting on the press table press out the bearing assembly.

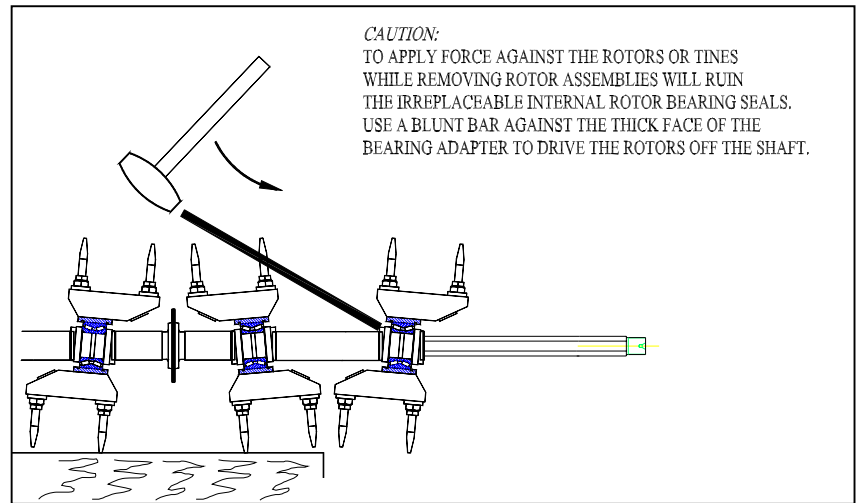

Figure 7. Disassembly of Rotor Shaft Assembly

II. Reassembly and Installation

(Be careful to keep all components clean to prevent bearing grease contamination)

A. Rotor Hub Re-Assembly.

1. Install internal snap ring in one side of rotor.
2. Press bearing and adapter assembly tight against the ring (see Figure 9).
3. Install second snap ring.
4. Apply a ribbon of general purpose grease between the snap ring ID and bearing adapter OD on both sides of rotor.

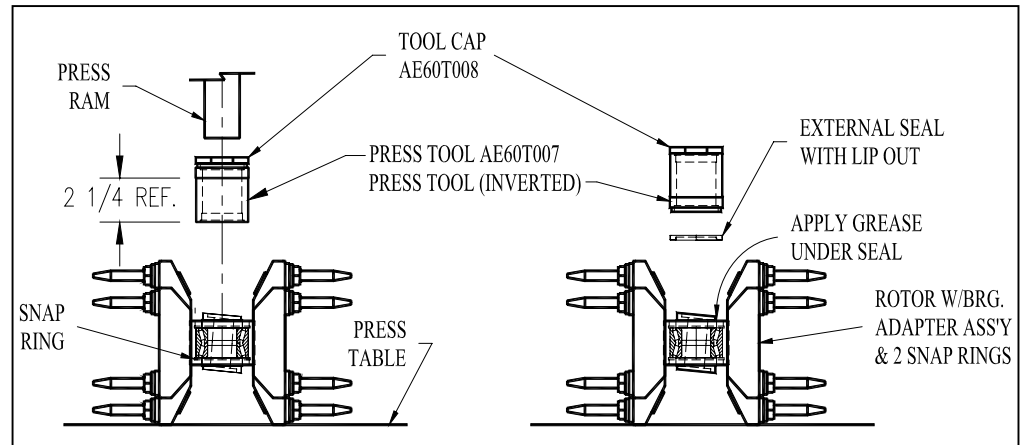

Figure 8. Rotor Assembly

5. With the press tool inverted to fit the external seals, press the seals in both ends of the rotor **with the lips out**. Wipe off excess grease. Be sure seals are not bent or cut and are seated firmly. **If the seals are not tight, use a hammer and punch to stake the hub faces at about 90° intervals.**

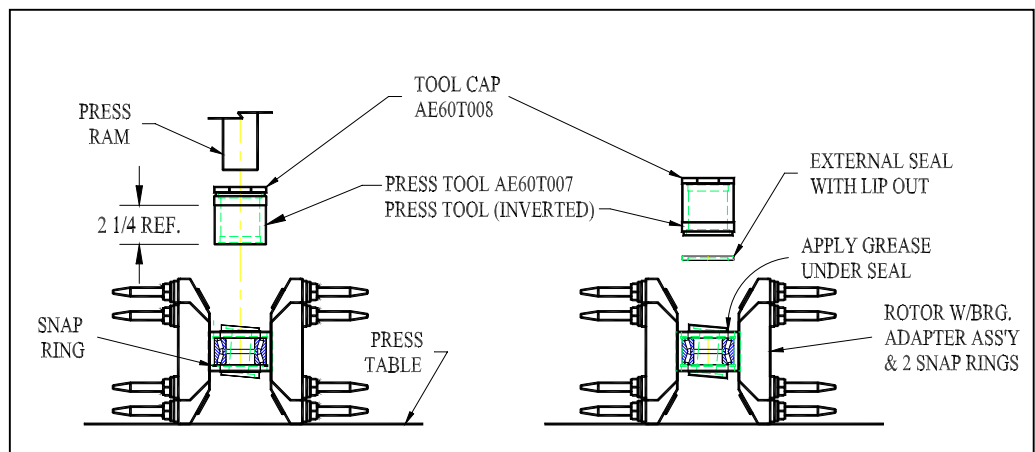

Figure 9. Rotor Hub Assembly

B. Assembly of Rotor Shaft.

CAUTION

IF THE BEARING ADAPTERS ARE NOT PRECISELY TIMED 180 DEGREES APART IN EACH ROTOR AND ALIGNED BETWEEN ROTORS, SERIOUS DAMAGE WILL RESULT.

1. Rotate the adapters in each rotor so the timing marks (see Figure 10) are phased 180 degrees apart with hex bores aligned.
2. To assist with aligning timing marks between rotors, use chalk or marker to mark two rotor shaft flats 180 degrees apart next to the threaded end. The selected flats would have to align with the timing marks on any rotors not removed during servicing.
3. Install the required components in the sequence shown in Figure 6, double-checking the timing mark locations and spacer lengths (see following table) as each rotor is installed.

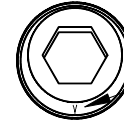

TIMING MARK FOR PHASING BEARING ADAPTERS IN THE ROTOR SHAFT ASSEMBLY

Figure 10. Timing Mark

SPACER	LENGTH (inches)
A	3 13/16
B	7 1/4
C	7 1/4
D	7 1/4
E	3 5/16

CAUTION

CLEAN THE ROTOR SHAFT THOROUGHLY REMOVING ANY BURRS THAT WOULD KEEP THE ROTOR ASSEMBLIES FROM SLIDING ON FREELY. IF A BEARING ADAPTER JAMS, THE INTERNAL BEARING SEAL COULD BE FORCED OUT AND IT IS NOT REPLACEABLE.

NOTE: THE SPACERS MUST BE FULLY SEATED IN EACH ADAPTER COUNTER BORE BEFORE TIGHTENING. DO NOT FORGET TO PLACE THE BEARING STAMPINGS ON EACH OF THE SHAFT BEARINGS DURING REASSEMBLY. ALSO, THE 3/8" CARRIAGE BOLTS SHOULD BE PLACED IN THE BEARING STAMPINGS ON THE DRIVE END OF THE SHAFT BEFORE THE SHEAVE IS REPLACED.

4. Replace the 1-1/8" hex jam nut and rotate each rotor occasionally as the nut is being torqued to 350 ft-lbs. If any rotor locks up, the bearing adapters in the rotor are probably not phased 180 degrees apart.

D. Installation of Main Shaft Assembly

Reinstall the rotor shaft into main frame by reversing the shaft removal steps outlined in I-A. Refer to Figure 6 for correct location of bearing stampings, bolts, etc. Tighten the 3/8 flange lock nuts at each bearing to 35 ft-lbs.

CAUTION

THE TWO STAMPINGS ON EACH BEARING ARE IN CONTACT WITH EACH OTHER IN THE ASSEMBLY. NEVER SEPARATE THE BEARING STAMPINGS TO STRADDLE A FRAME MEMBER.

E. After installing the belts and cover, run the machine and check for loose or improperly installed components.

TINE REPLACEMENT

Assemble tines to rotor as shown in the following figure. Torque tines to 210 ft-lbs.

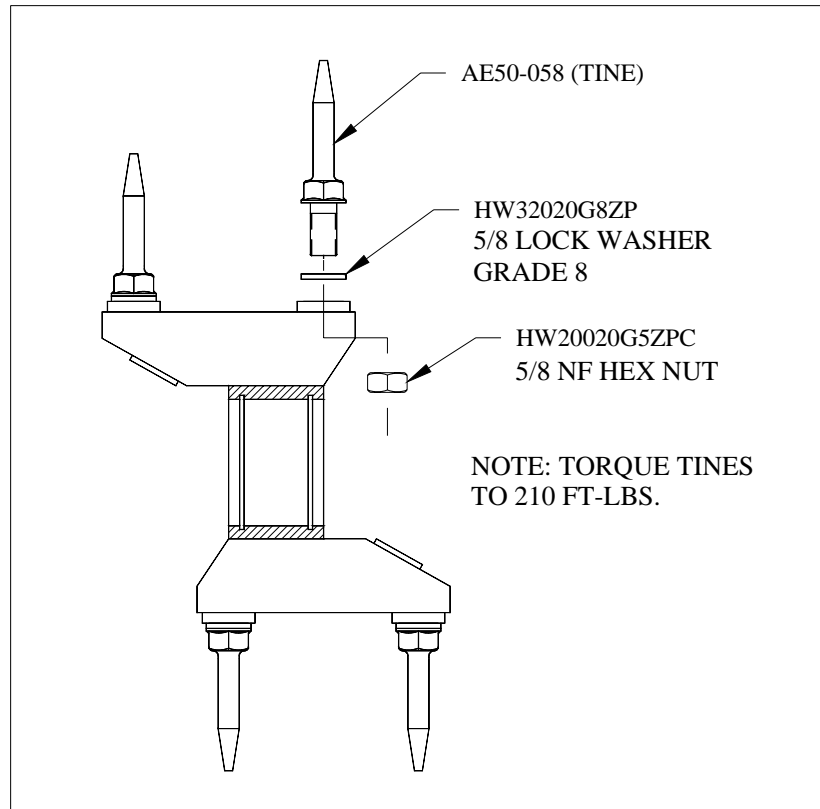

Figure 11. Tine Replacement

SEEDER MAINTENANCE

(Supplied from Gandy)

- Remove bottom and rotors using snap latches, and wing nuts securing bearing retainers. Clean all surfaces.
- Lightly oil bearings periodically, more often if metering material with fines as powder may work into bearings.
- Some materials may build up on the hopper bottom, especially when atmospheric humidity is high. It may be wise to remove slide from bottom for cleaning. To remove slide, remove the four nuts, nylon washers and slide hanger.
- Re-assemble slide onto hopper after cleaning. For proper slide tension, gently drive the hanger to the left, using a screw driver against the tab at the right end of the hanger. When the end of the hanger lines up with the scribed line on the hopper bottom, slide tension is correct. Bottom is ready for reinstallation.

SEEDER CALIBRATION

CALIBRATION

IT IS THE RESPONSIBILITY OF THE OPERATOR TO ENSURE THAT EACH BATCH OF SEED IS PROPERLY CALIBRATED IN THE SEEDER PRIOR TO APPLICATION. FAILURE TO DO SO MAY RESULT IN INADEQUATE OR EXCESSIVE SEED RATES. AFTER PROPER CALIBRATION, IN ADDITION TO USING CONSISTENT SEED, THE CHOSEN GAUGE SETTING AND GROUND SPEED MUST BE MAINTAINED TO OBTAIN THE CALIBRATED RATE.

THE SEEDING RATE CHART PROVIDED IS TO SERVE ONLY AS INITIAL SETTING GUIDE.

I. GENERAL OBSERVATIONS

Each product flows differently requiring calibration for each product. Variations in formulations, seed size, humidity, temperature and age of product may affect application rates.

The applicator depends on gravity flow of the product particles through precisely adjusted openings at each tube spout. The ground or electric driven rotor assures a constant flow when turning and interrupts the flow when it stops, allowing only the particles in the rotor segment exposed to the openings to flow out.

To close the hopper bottom openings, rotate the shut off lever counter-clockwise until the slide stop contacts the hopper stop. To open the hopper bottom openings, rotate the lever clockwise until the slide gauge cam contacts the hopper stop. The opening increases as the cam is rotated from 0 to 80.

II. CALIBRATION PROCEDURE

Establish the desired application rate based on lbs. per 1000 sq. ft. (Divide lbs. per acre by 43.6 to convert to lbs. per 1000 sq. ft. or refer to conversion chart (Figure 2)).

CONVERSION CHART
Lbs/1000 sq.ft - to - Lbs/acre

PER 1000 sq.ft		P O U N D S										
		0	1	2	3	4	5	6	7	8	9	10
Tenths of a Pound	0		44	87	131	174	218	261	305	348	392	436
	0.1	4	48	91	135	179	222	266	309	353	396	440
	0.2	9	52	96	139	183	227	270	314	357	401	444
	0.3	13	57	100	144	187	231	274	318	362	405	449
	0.4	17	61	105	148	192	235	279	322	366	409	453
	0.5	22	65	109	152	196	240	283	327	370	414	457
	0.6	26	70	113	157	200	244	287	331	375	418	462
	0.7	30	74	118	161	205	248	292	335	379	423	466
	0.8	35	78	122	166	209	253	296	340	383	427	470
	0.9	39	83	126	170	213	257	301	344	388	431	475

Lbs/Acre

Figure 2. Conversion Chart

- A. After considering the site to be seeded (shape, soil texture, slope, obstacles, etc.), set your tractor ground speed (MPH). Select a gear setting that will provide the desired MPH and maintain a PTO speed between 500 and 600 RPM or as required for the degree of tillage desired. The ground speed can be verified by determining the time required to travel a distance of 200 ft. per the following speed/time chart:

Speed MPH	Time Required per 200'	Speed MPH	Time Required per 200'	Speed MPH	Time Required per 200'
		2 ½	55 sec	4 ½	30 sec
1	2 min 16 sec	3	45 sec	5	27 sec
1 ½	1 min 31 sec	3 ½	39 sec	5 ½	25 sec
2	1 min 8 sec	4	34 sec	6	23 sec

- B. Fix the preliminary cam gauge setting for your selected seed using your best judgment.
- C. Collect and weigh the seeder output for 1000 sq. ft.
- a. Place seed in hopper with control lever closed.
 - b. Place empty container on one of the spouts to catch seed (To prevent loss of seed, block off other spouts).
 - c. Start motor
 - d. After waiting 15 to 20 seconds, open the control lever for the time required to travel 200 ft. that corresponds with the set speed (see speed/time chart).
 - e. Close the control lever after it has been open the exact time required.
 - f. Weigh the collected seed and multiply times 23 for total output and compare to the desired rate per 1000 sq. ft.
 - g. Adjust the cam gauge and repeat the procedure as required.

WARRANTY INFORMATION

ONE YEAR LIMITED WARRANTY

FIRST PRODUCTS INC. WARRANTS THIS PRODUCT TO BE FREE OF DEFECTS IN MATERIALS AND WORKMANSHIP FOR A PERIOD OF TWELVE MONTHS FROM THE ORIGINAL DELIVERY DATE. THIS WARRANTY DOES NOT COVER PARTS CAUSED TO BE DEFICIENT DUE TO NORMAL WEAR, MISUSE, ACCIDENTS, OR LACK OF PROPER MAINTENANCE.

ANY PARTS THOUGHT TO BE DEFECTIVE MUST BE RETURNED TO THE DEALER/DISTRIBUTOR FOR WARRANTY CONSIDERATION JOINTLY WITH FACTORY REPRESENTATIVES. A RETURN AUTHORIZATION NUMBER MUST BE OBTAINED AND CLEARLY MARKED ON ALL PACKAGES OF PARTS REQUIRING RETURN TO THE FACTORY.

THE OBLIGATION OF FIRST PRODUCTS INC. UNDER THIS WARRANTY SHALL BE EXCLUSIVELY LIMITED TO REPLACEMENT OF PARTS DETERMINED TO BE DEFECTIVE BY FIRST PRODUCTS INC. WITH FREIGHT PREPAID. IN NO EVENT SHALL FIRST PRODUCTS INC. BE LIABLE FOR INDIRECT, INCIDENTAL, OR CONSEQUENTIAL DAMAGES IN CONNECTION WITH THE USE OF THIS PRODUCT.

FIRST PRODUCTS INC. RESERVES THE RIGHT TO MAKE CHANGES OR ADD IMPROVEMENTS TO ITS PRODUCTS AT ANY TIME WITHOUT OBLIGATION TO MAKE SUCH CHANGES OR IMPROVEMENTS ON PRODUCTS SOLD PREVIOUSLY.

MAIN FRAME ASSEMBLY

ITEM NO.	ORDER NO.	DESCRIPTION	ITEM NO.	ORDER NO.	DESCRIPTION
1	AE26-034	ROTOR SHAFT-40	13	AE50-086	2B 4.65 X 1-1/8" HEX BORE SHEAVE
2	HW32036G5ZP	1-1/8" LOCKWASHER	14	AE23-152	INPUT SHIELD-40L (NOT SHOWN)
3	HW25036G5ZPF	1-1/8"-12 JAMNUT N.F.	15	AE24-029	RIGHT END SPACER (3-5/16")
4	AE81-012	ROTOR COMPLETE	16	AE50-114	DANGER HAZARD DECAL (NOT SHOWN)
5	AE24-011	LONG SPACER (7-1/4")	17	AE50-076	THROWN OBJECT HAZARD
6	AE24-027	DRIVE END SPACER (3-13/16")	18	AE50-124	AE 40 DECAL
7	HW03012032G5ZPC	3/8" X 1" CARRIAGE BOLT	19	FB50-068	F.P. LOGO DECAL (NOT SHOWN)
8	HW22012G5ZPC	3/8" FLANGE LOCKNUT	20	AE50-113	SWING FRAME HAZ. WARNING (NOT SHOWN)
9	AE80-094	MAIN FRAME -40L	21	AE50-074	GENERAL CAUTION (NOT SHOWN)
10	AE50-094	72MM X 4 HOLE FLANGE	22	AE50-077	540 PTO ONLY (NOT SHOWN)
11	AE50-090	1-1/8" HEX BEARING	23	AE50-032	U.S. PATENT DECAL (NOT SHOWN)
12	AE50-063	AERA-vator DECAL			

NOT SHOWN:

CAUTION STICKER (21) ON EACH SIDE OF INPUT SHIELD (14),
 540 PTO ONLY STICKER (22) ON TOP OF INPUT SHIELD,
 AND DANGER HAZARD DECAL (16) UNDER INPUT SHIELD.

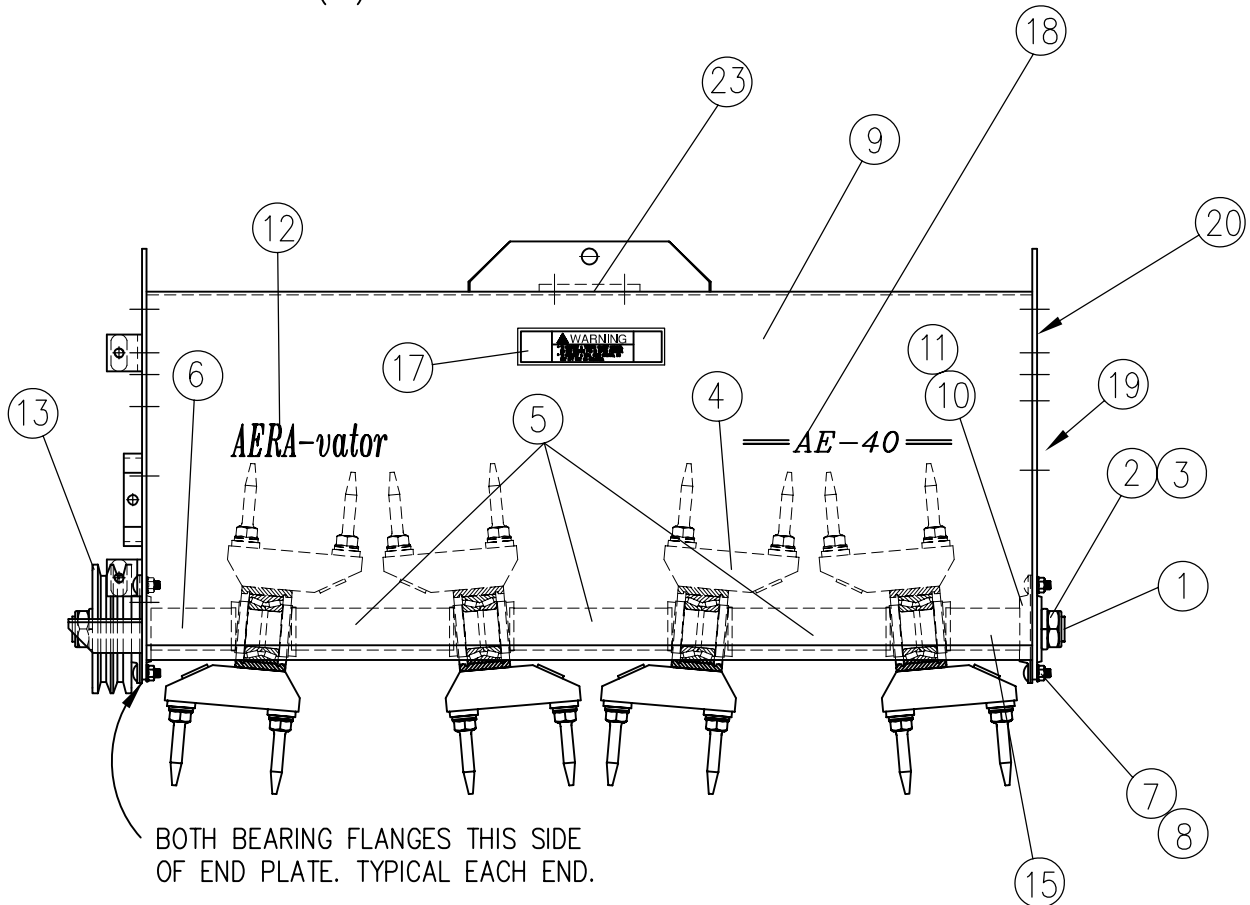

DRIVE TRAIN COMPONENTS

ITEM NO.	ORDER NO.	DESCRIPTION	ITEM NO.	ORDER NO.	DESCRIPTION
1	AE50-006	COUPLER CHAIN CPT.	19	AE24-047	COUPLER SHIELD
2	AE50-007	#40-2 CHAIN CONN.	20	HW25010G5ZPC	5/16 HEX JAM NUT
3	AE50-046	#40B16 X 1-1/8"	21	HW07010032PLC	5/16" X 1" SQ HEAD SETSCREW
4	AE50-047	#40B16 X 30MM	22	HW05010024G2ZPC	5/16 X 3/4 HEX HD FLG CAPSCREW
5	AE50-085	1/4" X 2"(1045) KEY	23	HW32012G5ZP	3/8" LOCK WASHER
6	AE26-035	JACK SHAFT (1-1/8") - 40L	24	HW03010024G5ZPC	5/16" X 3/4" CARRIAGE BOLT
7	AE50-048	1-1/8" BEARING	25	HW22010G5ZPC	5/16 FLANGE LOCK NUT
8	AE50-053	62MM X 3 HOLE HVY. FLANGE	26	HW03012032G5ZPC	3/8" X 1" CARRIAGE BOLT
9	AE80-095	BELT SHIELD - 40L	27	HW01012032G5ZPC	3/8" X 1" HEX CAP SCREW
10	HW03020080G2ZPC	5/8" X 2-1/2" CARRIAGE BOLT	28	HW20012G5ZPC	3/8" HEX NUT
11	AE50-087	2B 6.9 X 1-1/8"DIA. BORE SHEAVE	29	HW20020G5ZPC	5/8" HEX NUT
12	AE50-086	2B 4.65 X 1-1/8 HEX BORE SHEAVE	30	HW32020G5ZP	5/8" LOCK WASHER
13	AE50-122	BX 40 BELTS	31	HW22012G5ZPC	3/8" FLANGE LOCK NUT
14	AE50-118	4" BELT IDLER-2B	32	AE50-113	SWINGING FRAME HAZARD DECAL
15	AE24-040	BELT IDLER SPACER - 40L	33	FB50-068	F.P. LOGO DECAL
16	AE23-010	SKID SHOE	34	HW07010024PLC	5/16 X 3/4 SQ. HD. SETSCREW
17	AE50-052	8MM X 40MM KEY	35	AE54-018	GEAR BOX
18	AE80-092	BELT IDLER BRACKET - 40L			

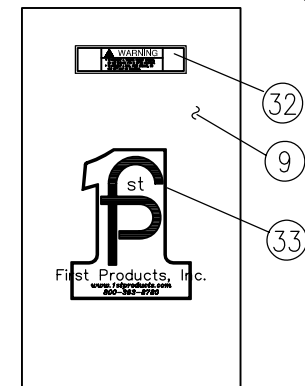
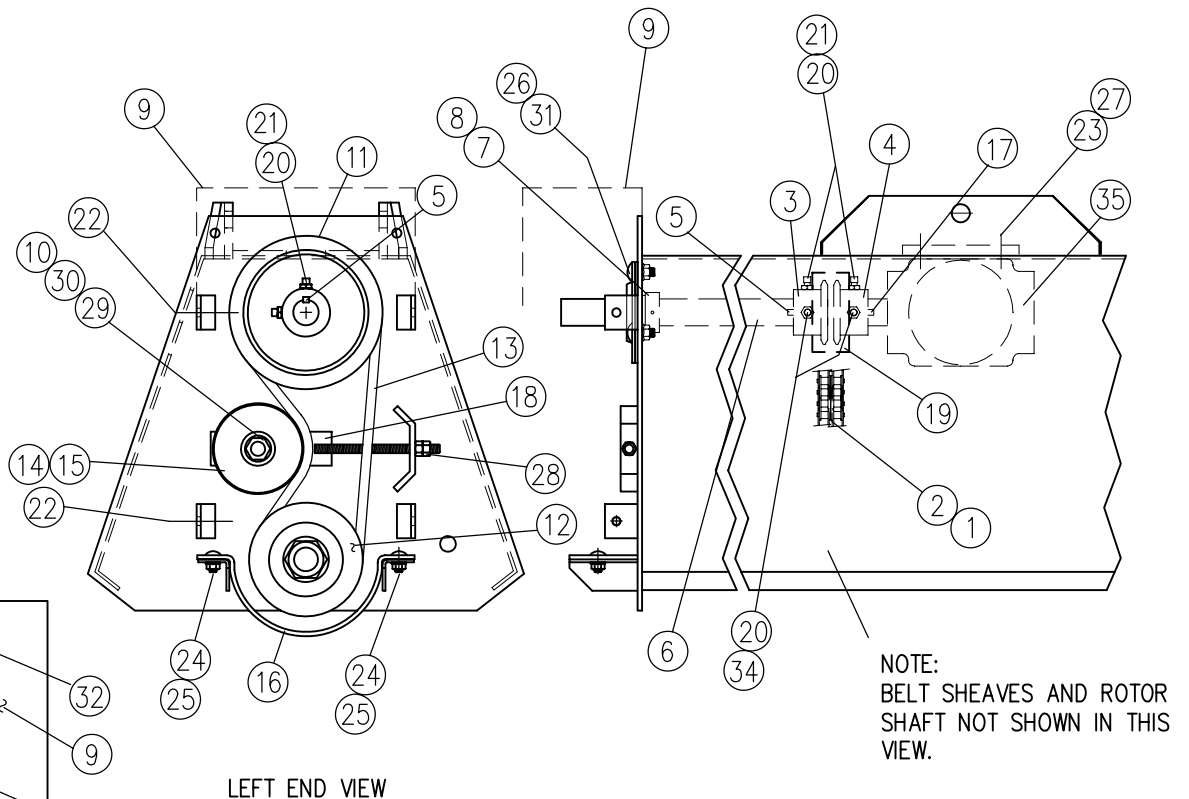

END VIEW OF BELT COVER

LIFT AND TRAIL HITCH

ITEM NO.	ORDER NO.	DESCRIPTION	ITEM NO.	ORDER NO.	DESCRIPTION
1	AE80-099	"A" FRAME - 40L	20	HW30012TAZP	3/8" FLAT WASHER
2	AE80-090	SWING MAST - 40L	21	HW24012GBZPC	3/8" STOVER LOCKNUT
3	AE80-087	SWING STAND - 40L	22	HW4000403ZPC	1/8" X 1" COTTER
4	AE80-093	CLEVIS - 40L	23	AE50-063	AERA-vator DECAL
5	AE80-006	SWING LOCK - 60	24	HW01012040G5ZPC	3/8" X 1-1/4" HEX CAP G5
6	AE80-089	SWIVEL PIN - 40L	25	AE50-059	SMALL F.P. DECAL
7	AE50-134	9/16" X 4 X .047 SPRING (Not Shown)	26	HW01012032G5ZPC	3/8" X 1" HEX CAP G5
8	AE80-096	SWING LOCK LINK - 40L	27	HW22012G5ZPC	3/8" FLANGE LOCK NUT
9	AE80-011	LOCK HINGE PIN - 60	28	HW25020G5ZPC	5/8" JAM NUT
10	AE80-017	LOCK SETSCREW - 60	29	HW32024G5ZP	3/4" LOCK WASHER
11	HW25024G5ZPC	3/4" HEX JAM NUT	30	HW31012TAZP	3/8" FLATWASHER SAE
12	AE50-069	1/4" HIGH TEST CHAIN X 9 LINKS	31	AE50-040	3/8" X 1-1/2" PIN
13	AE50-022	LOCK SPRING	32	HW20028G5ZPF	7/8" NF HEX NUT
14	AE50-023	LIFT ARM PIN	33	AE50-075	CAUTION (PINCH POINT)
15	AE50-120	3/4" X 1" FLANGE BEARING	34	AE50-163	P.B. CYLINDER CLAMP
16	HW33028G8ZP	7/8" HVY. L'WASHER	35	AE50-164	P.B. CYLINDER
17	AE26-036	MAST HINGE ROD - 40L	36	HW01008024G2ZPC	1/4" x 3/4" HEX CAPSCREW
18	HW31028TAZP	7/8 SAE FLAT WASHER	37	HW22008G5ZPC	1/4" FLANGE LOCKNUT
19	HW40006040ZP	3/16" X 1-1/4" COTTER	38	HW20008G5ZPC	1/4" HEX NUT

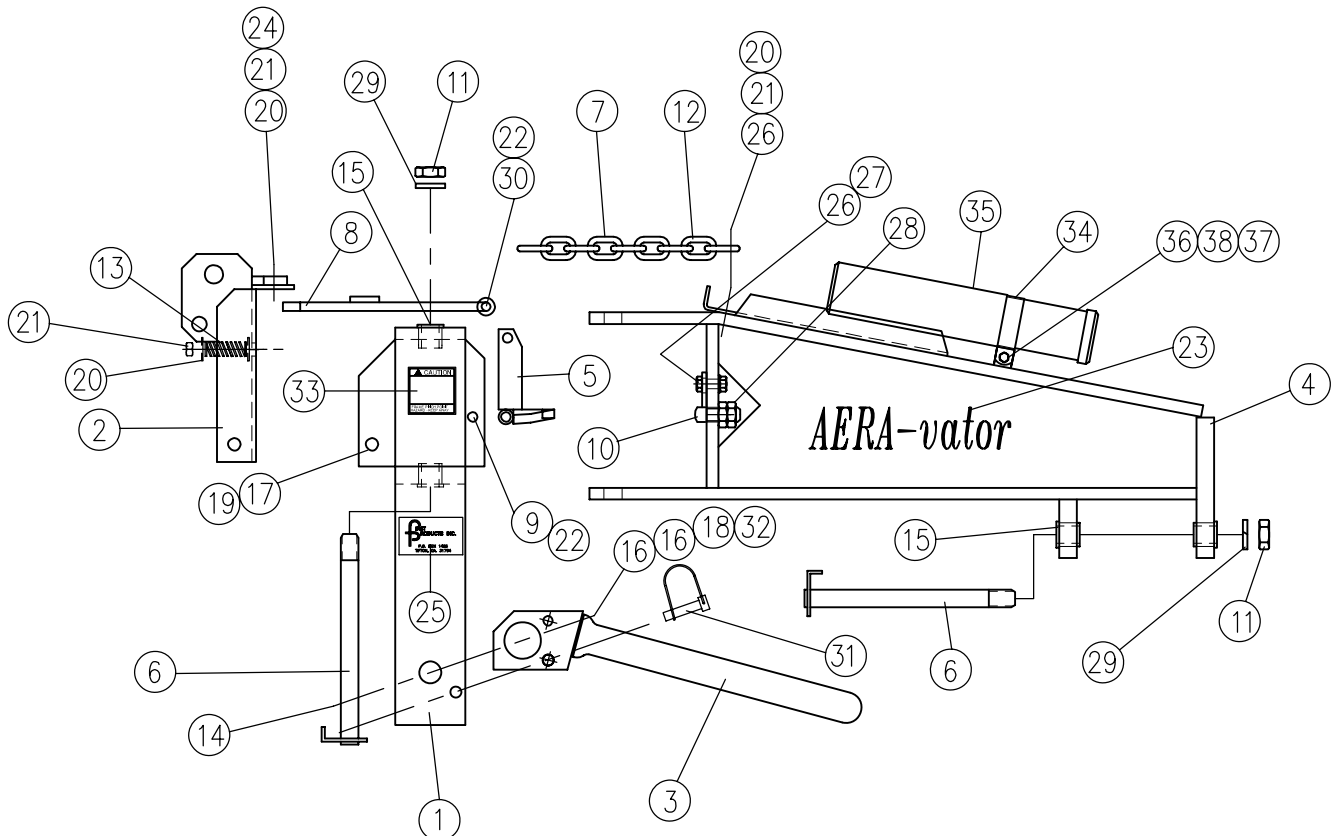

ROTOR ASSEMBLY

AE81-011 Consists of:
 AE50-055 ROTOR BEARING
 AE50-004 BRG. ADAPTER
 AE50-029 3" SNAP RING - INT.
 AE50-005 EXTERNAL ROTOR SEAL
 AE80-027 ROTOR

ITEM NO.	ORDER NO.	DESCRIPTION
1	AE81-010	AE 5° BRG. & ADAPTER
2	AE50-029	3" SNAP RING-INTERNAL
3	AE50-005	EXTERNAL ROTOR SEAL
4	AE50-058	TINE-5/8 N.F.
5	HW32020G8ZP	5/8" LOCK WASHER GRD. 8
6	HW20020G5ZPC	5/8" HEX NUT
7	AE80-027	ROTOR ONLY
8	AE81-011	ROTOR ASSEMBLY W/O TINES
9	AE60T003	EXTRA DEEP IMPACT SOCKET

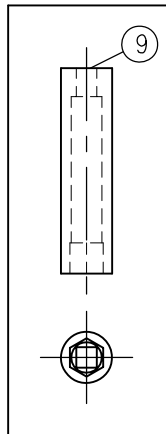
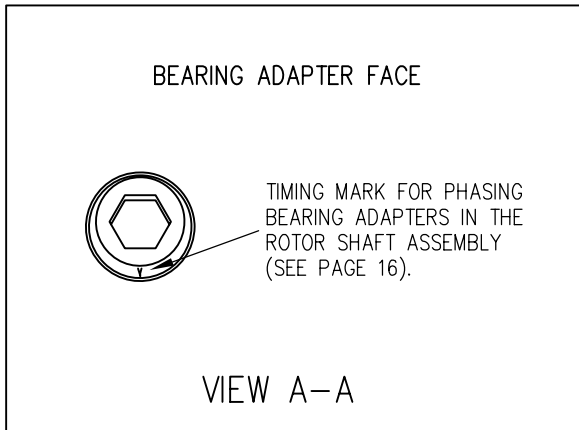

NOTE: TORQUE TINES TO 210 FT. LBS.

ASSEMBLE SEALS WITH LIP OUT

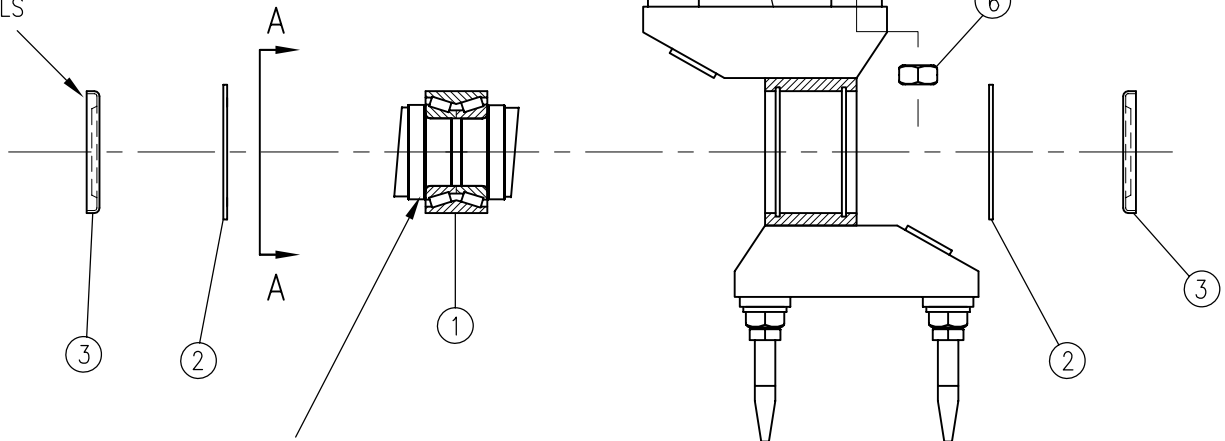

CAUTION: INTERNAL BEARING SEALS ARE NOT TO BE REMOVED.

DRIVE LINE COMPONENTS

AE55-074 (COMPLETE DRIVE LINE)

ITEM NO.	ORDER NO.	DESCRIPTION
1	AE55-002	CROSS KIT
2	AE55-075	CPL. SHIELD ASSEMBLY
3	AE55-076	OUTER SHAFT W/ SHIELD
4	AE55-077	INNER SHAFT W/ SHIELD
5	AE55-074	COMPLETE DRIVE LINE

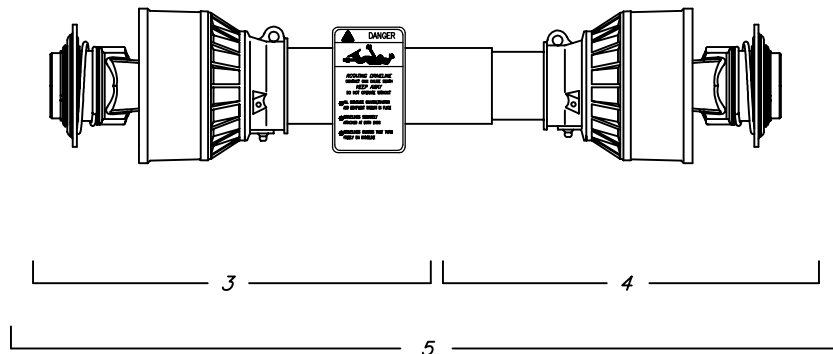
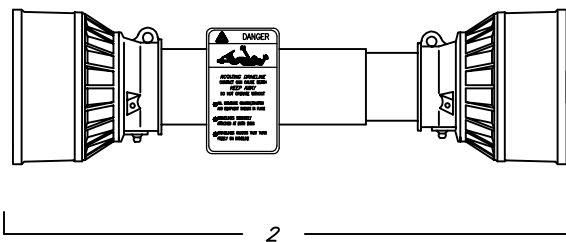
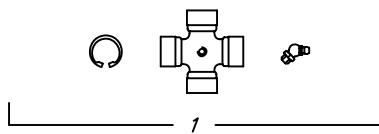

SMOOTHING ROLLER

ITEM NO.	ORDER NO.	DESCRIPTION	ITEM NO.	ORDER NO.	DESCRIPTION
1	AE26-015	ROLLER SPRING ROD	13	AE50-013	52MM FLANGE
2	AE80-086	SPRING ROD SUPPORT - 40L	14	HW40006040ZP	3/16" X 1-1/4" COTTER PIN
3	HW24012GBZPC	3/8" STOVER LOCKNUT	15	HW01012032G5ZPC	3/8 X 1 HEX CAPSCREW GD 5
4	AE80-098	ROLLER END PLATE (RIGHT) - 40	16	HW22012G5ZPC	3/8" FLANGE LOCKNUT
5	AE80-097	ROLLER END PLATE (LEFT) - 40	17	HW03010024G5ZPC	5/16 X 3/4 CARRIAGE BOLT GD 5
6	AE23-150	SCRAPER - 40	18	HW30016TAZP	1/2" FLATWASHER
7	AE80-085	ROLLER - 40	19	HW24016GBZPC	1/2" STOVER LOCKNUT
8	AE80-088	ROLLER FRAME BRACE - 40L	20	HW01016080G5ZPC	1/2 X 2 1/2 HEX CAPSCREW GD 5
9	AE50-147	SHOCK BUSHING	21	HW04010016PLC	5/16" X 1/2" HH TYPE B SELF THD. SCREW
10	AE50-071	ROLLER SPRING	22	HW22010G5ZPC	5/16" FLANGE LOCKNUT
11	FB50-022	11/16" ADJ. COLLAR	23	AE24-046	SHOCK BUSHING SLEEVE
12	AE50-103	1" SPH. BEARING W/SET SCREWS	24	HW07016020PLC	1/2 x 5/8 SQ. HD. CUP POINT SS

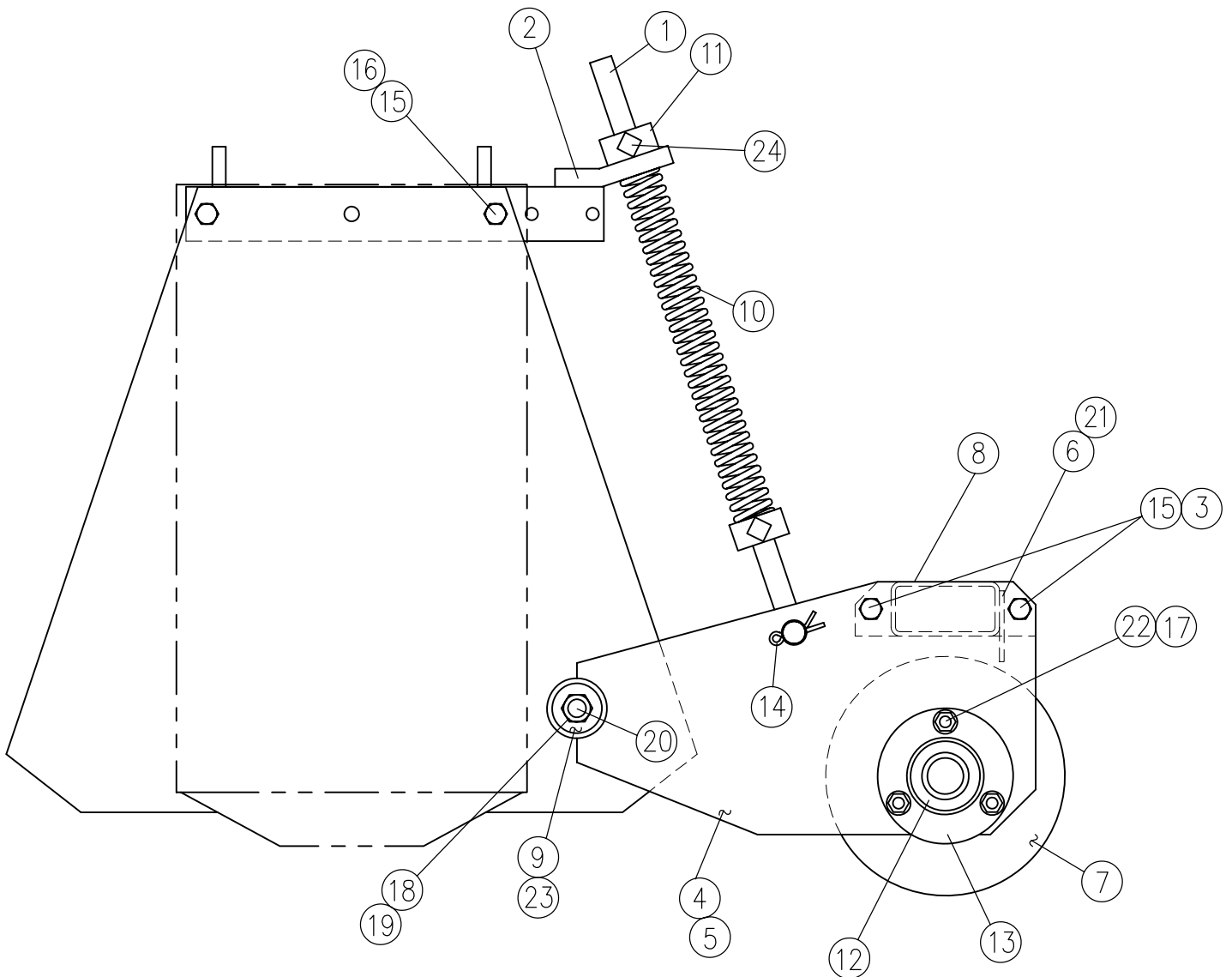

GROOMING RAKE & BRUSH

ORDER NO. AE82-030

ITEM NO.	ORDER NO.	DESCRIPTION	ITEM NO.	ORDER NO.	DESCRIPTION
1	AE50-159	Brush	11	HW03012040G5ZPC	3/8 x 1 1/4 Carriage Bolt G5
2	AE80-131	Groom Rake/Brush Frame	12	AE80-134	Groom Rake/Brush Arm
3	AE23-205	Washer	13	AE50-160	2 1/4" "S" Hook
4	AE50-178	Rake Tine	14	HW24016GBZPC	1/2 Stover Lock Nut
5	AE50-192	Hanger Chain - 40	15	HW03016056G5ZPC	1/2" x 1 3/4" Carriage Bolt
6	AE80-133	Groom Rake/Brush Mount	16	HW40004032ZP	1/8 x 1 Cotter Pin
7	HW03010064G2ZPC	5/16" x 2" Carriage Bolt	17	HW01010024G5ZPC	5/16 X 3/4 Hex Capscrew
8	HW22010G5ZPC	5/16" Hex Flange Lock Nut	18	AE80-146	AE40L Grm Rake/Brush Chain Catch - LT
9	AE80-130	Tine Rod - 40	19	AE80-147	AE40L Grm Rake/Brush Chain Catch - RT
10	HW31016TAZP	1/2" Flat Washer Sac			

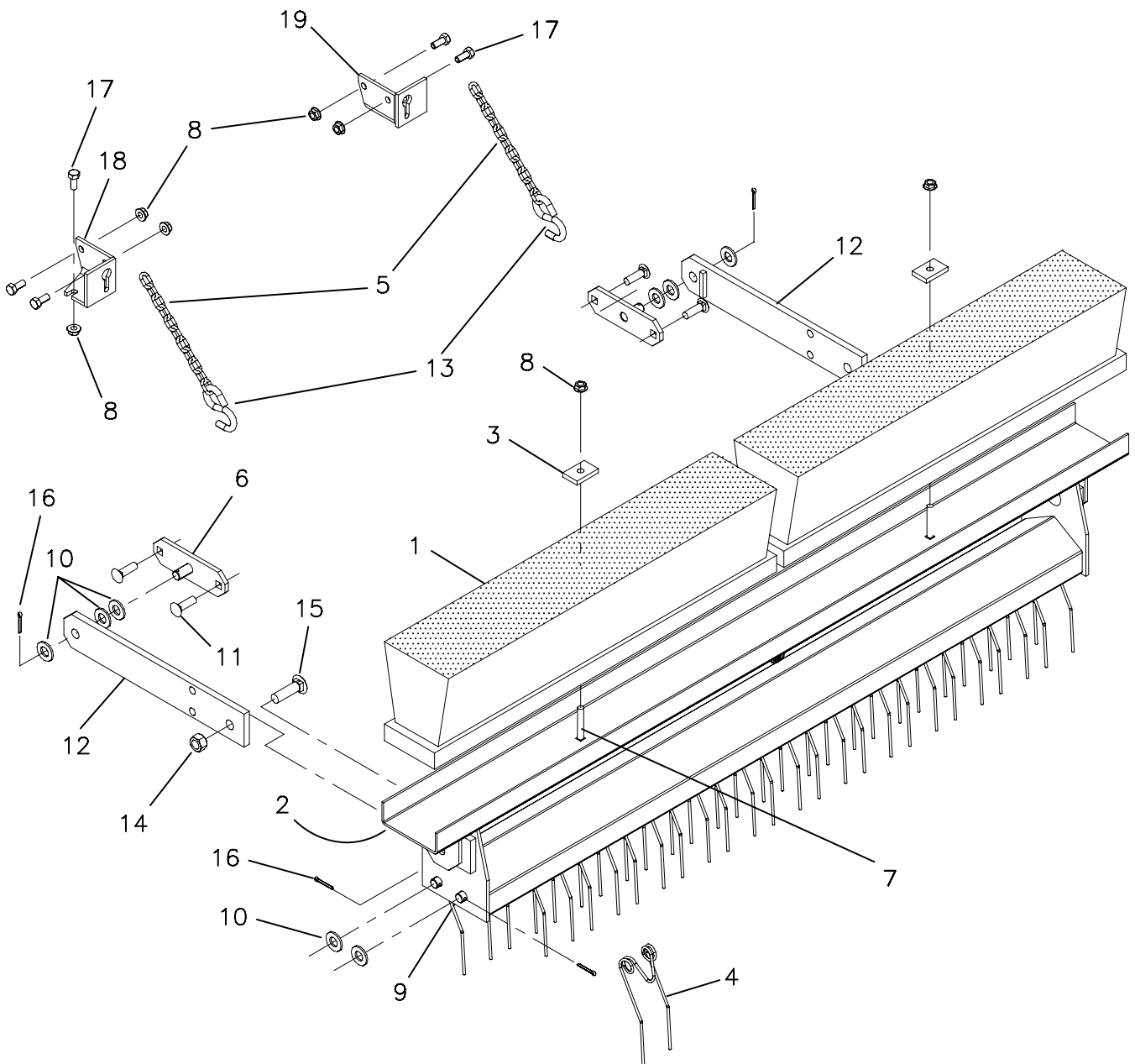

40L SEEDER MOUNTING

ITEM	PART NO.	DESCRIPTION	QTY.	ITEM	PART NO.	DESCRIPTION	QTY.
1	28116-A **	42" SEEDER DRIVE MOTOR	0	17	FA50-051	SMV "U" BOLT	6
2	AE23-249	40" SEED SPREADER	1	18	HW01008024G5ZPC	1/4 x 3/4 HEX CAPSCREW	4
3	AE23-250	COUNTER WEIGHT-16 LBS	1	19	HW01012024G5ZPC	3/8 X 3/4 HEX CAPSCREW GD 5	4
4	AE24-056	LOWER SUPPORT TUBE	1	20	HW01012032G5ZPC	3/8 X 1 HEX CAPSCREW G5	4
5	AE27-028	SEEDER HOSE CLAMP	10	21	HW01012064G5ZPC	3/8 X 2 HEX CAPSCREW G5	2
6	AE50-202	7/8" I.D. HOSE-28" LG	4	22	HW01012072G5ZPC	3/8 X 2 1/4 HEX CAPSCREW G5	2
7	AE50-203	7/8" I.D. HOSE-26" LG	16	23	HW03008016G5ZPC	1/4 X 1/2 CARRIAGE BOLT GD 5	10
8	AE50-204 *	HOSE CLAMP-1 3/32"	20	24	HW06010020G5ZPC	5/16 X 5/8 FLG LK SCREW	2
9	AE50-205	CAP, VINYL-3/4 I.D. X 1 LG	3	25	HW06010032G5ZPC	5/16 X 1 FLG LK SCREW	2
10	AE80-148	LOWER SUPPORT BRACKET	2	26	HW20012G5ZPC	3/8 HEX NUT	4
11	AE80-149	UPPER SUPPORT BRACKET	2	27	HW22008G5ZPC	1/4 FLANGE LOCK NUT	14
12	AE80-150	SPREADER BAR BRACKET	2	28	HW22010G5ZPC	5/16 FLANGE LOCK NUT	12
13	DO23-013	HOPPER AUX.MOUNT ARM	2	29	HW22012G5ZPC	3/8 FLANGE LOCK NUT	6
14	DO50-011 **	42" SEEDER BOX	0	30	HW24012GBZPC	3/8 STOVER LOCK NUT	2
15	DO80-007	42" SEEDER BOX MOUNT	1	31	HW30012TAZP	3/8 FLATWASHER	4
16	FA50-049	FIRST PRODUCTS DECAL	1	32	HW32012G5ZP	3/8 LOCKWASHER	4

*** ITEM NOT SHOWN**

**** SEE PAGES 26-28**

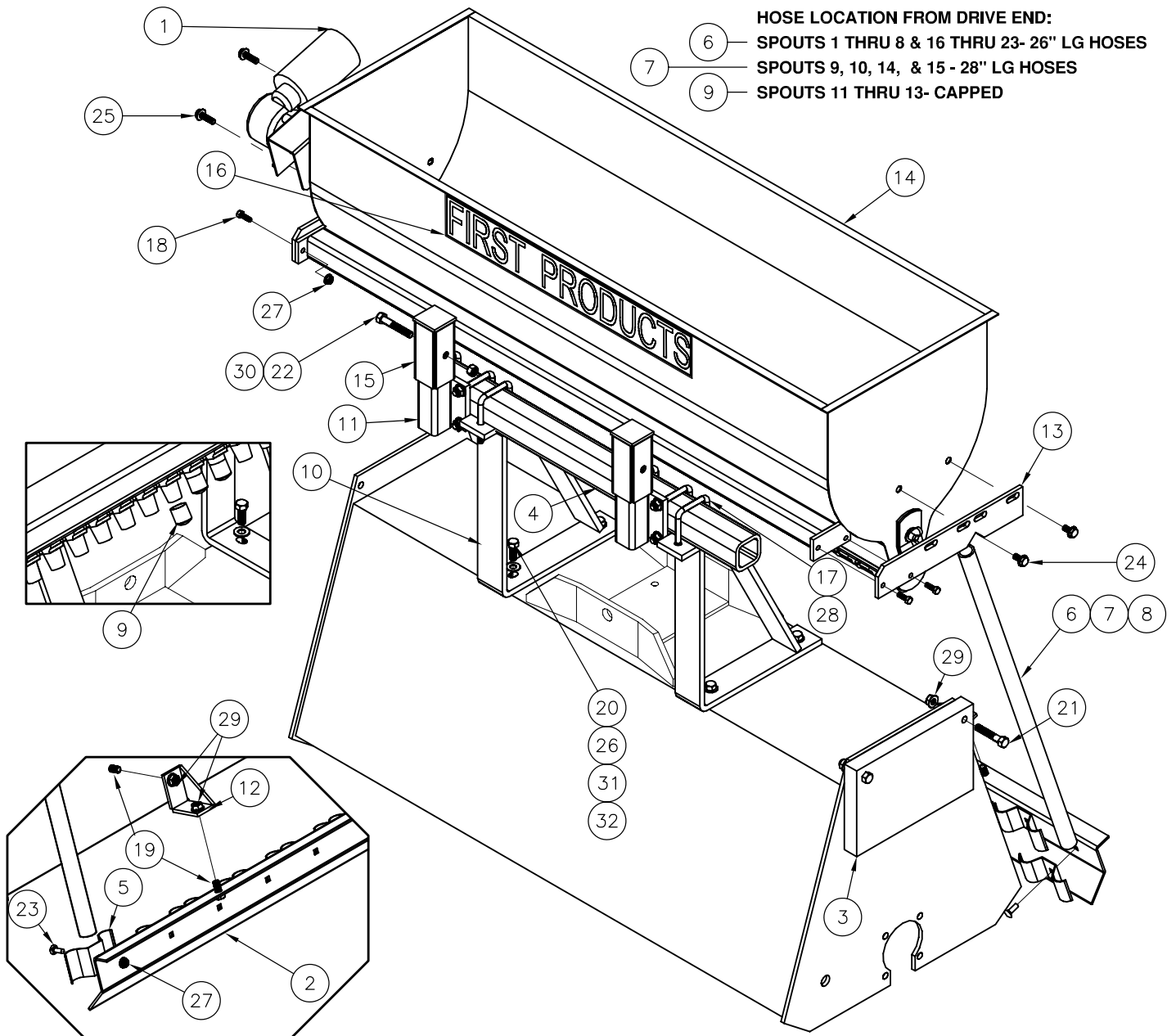

42" SEEDER DRIVE

GANDY#: 28116-A

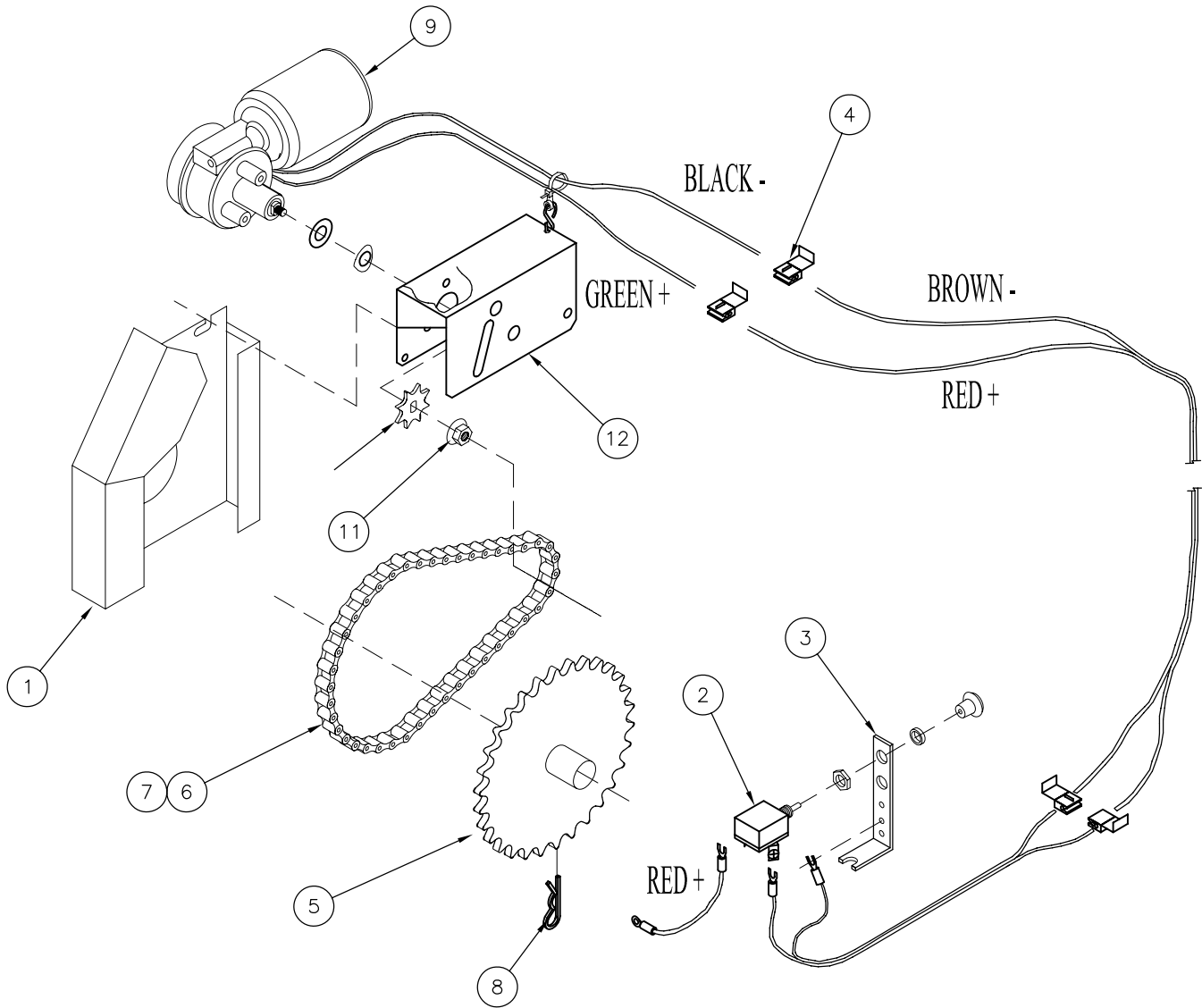

ITEM	PART NO.	DESCRIPTION	QTY
1	09077589-22	GUARD, ELECTRIC MOTOR	1
2	L05-0001-000	ELECTRIC SWITCH	1
3	09073589-9	MOUNTING BRACKET , SWITCH	1
4	567	WIRE CONNECTORS	4
5	28116-3	SPROCKET 32T, #41, 5/8" HEX BORE	1
6	F02-0041-000	ROLLER CHAIN, #41, 44 LINK	1
7	F02-0041-001	CONNECTOR LINK, #41	1
8	C21-0177-020	HAIR PIN COTTER, 3/16-#8	1
9	09082842-4	ELECTRIC MOTOR ASSEMBLY	1
10	09071589-6	DRIVE SPROCKET, 8T	1
11	C01-0312-030	WHIZ LOCK FLANGE NUT (5/16)	1
12	09077589-3	MOUNT, ELECTRIC MOTOR	1

42" SEEDER PARTS LIST

FP#: D050-011

GANDY #: 2842FP

ITEM	PART NO.	DESCRIPTION	QTY
1	28421-C2R	HOPPER	1
2	28426919-C1R	COVER	1
3	140692-C2	END BEARING	2
4	M05-0773-000	GASKET	2
5	09063146-C1	RETAINER	2
6	2894-20C1	BOTTOM AND SLIDE, 42" 23 SPOUTS	1
7	208692	LATCH	6
8	141469-4	ROTOR BAR, RUBBER, 42"	1
9	2894-26	JOURNAL, HEX	2
10	2807953-C1	CENTER PLATE	1
11	2894-21	CLEVIS, HITCH POLE	1
12	2807373	SPACER, CLEVIS	1
13	2891-8	LOWER HANDLE, 2842FP	1
14	2807175	CAM GAUGE	1
15	28426912	SLIDE HANGER	1
16	J01-0750-300	GRIP	1
17	2806920	HINGE	2

SEEDER HOPPER

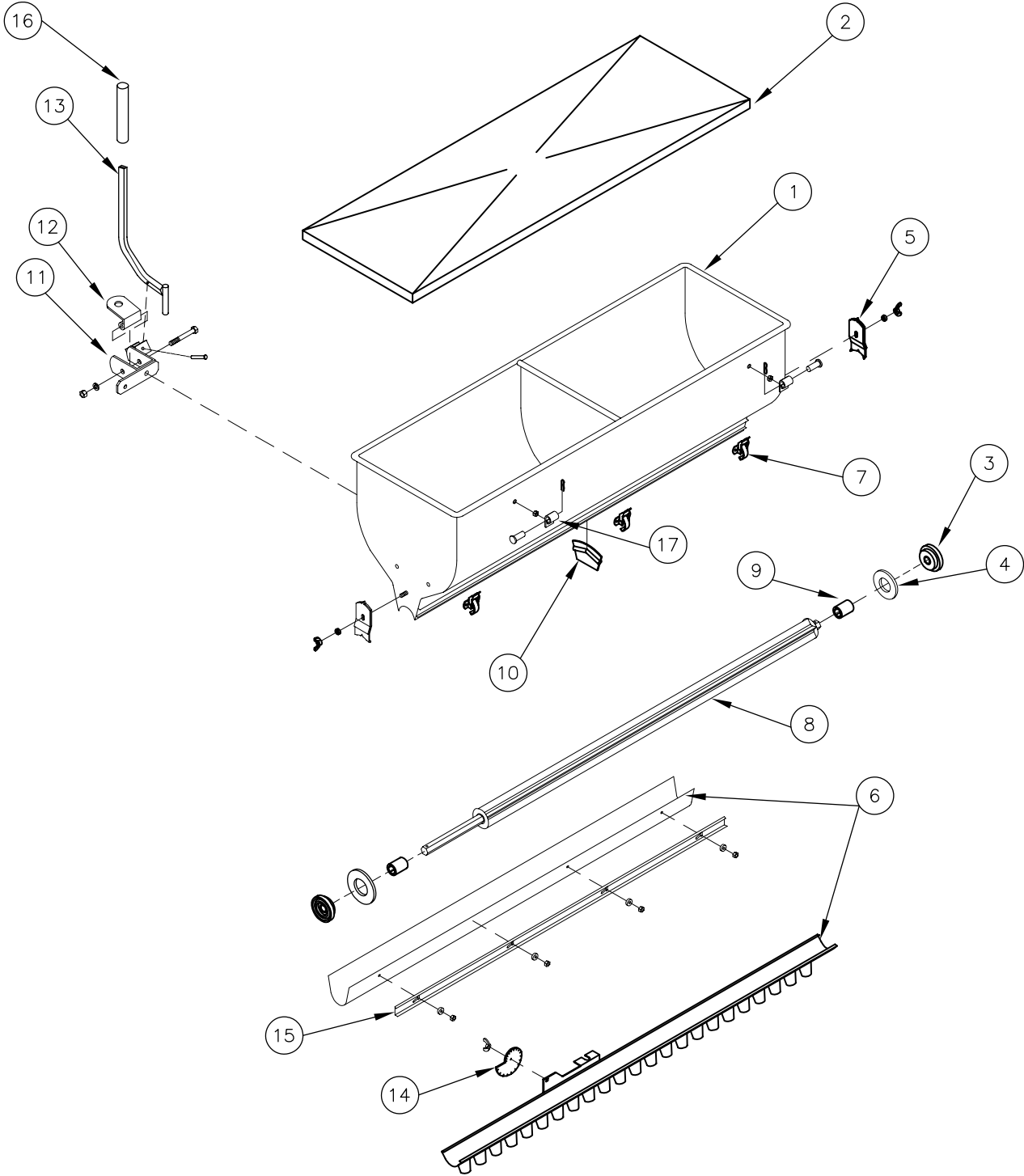

NOTES

SPECIFICATIONS

AE40L

WEIGHT w/ROLLER <i>WITHOUT SEEDER</i>	586 LBS
WEIGHT <i>WITH SEEDER</i> (EMPTY HOPPER)	705 LBS
OVERALL WIDTH <i>WITHOUT SEEDER</i>	44"
OVERALL WIDTH <i>WITH SEEDER</i>	48"
GROOM RAKE & BRUSH	48 LBS
WORKING WIDTH	40"
GEARBOX	1:1 RT. ANGLE
END DRIVE	2 BX BELTS
HITCH-LIFT	HEAVY DUTY TRAIL, 3 FT TURN RADIUS (APPROX.)
DRIVE LINE	1 3/8 SPLINE w/SAFETY SHEILD
TINE VIBRATION FREQUENCY	@540 PTO RPM = 800 CYCLES/MIN.
SIDE TO SIDE TINE TRAVEL	1 3/8 INCHES
VIBRATING DEPTH	3 1/2 INCHES
TINES	9/16 x 3 1/2" FORGED AND HARDENED
ROTOR BEARINGS	DOUBLE SEALED TAPERED ROLLER
FINISH - BASIC UNIT	BLACK AND GREY ACRYLIC
FINISH - HOPPER	RED POLYESTER
HOPPER CAPACITY	3.7 Cubic Ft.
HOPPER BOTTOM & SLIDE	STAINLESS STEEL (MICRO-PRECISION MATED)
SEED FEED ROTOR	PRECISION NEOPRENE
SEED DISTRIBUTION	23 OUTLETS WITH SPLASH PLATE
RATE CONTROL	PRECISION CAM GAUGE
SEEDER DRIVE	ELECTRIC DRIVE – (CONNECTS TO POWER UNIT BATTERY)
TRACTOR REQUIRMENTS: HP & PTO SPEED LIFT	13 HP @ 540RPM 3 PT HITCH- CAT. 1

SPECIFICATIONS SUBJECT TO CHANGE WITHOUT NOTICE

Free Manuals Download Website

<http://myh66.com>

<http://usermanuals.us>

<http://www.somanuals.com>

<http://www.4manuals.cc>

<http://www.manual-lib.com>

<http://www.404manual.com>

<http://www.luxmanual.com>

<http://aubethermostatmanual.com>

Golf course search by state

<http://golfingnear.com>

Email search by domain

<http://emailbydomain.com>

Auto manuals search

<http://auto.somanuals.com>

TV manuals search

<http://tv.somanuals.com>