

HP10000 Series Rack Reference Guide



December 2002 (Second Edition)
Part Number 258200-002

Hewlett-Packard Company shall not be liable for technical or editorial errors or omissions contained herein. The information in this document is provided “as is” without warranty of any kind and is subject to change without notice. The warranties for HP products are set forth in the express limited warranty statements accompanying such products. Nothing herein should be construed as constituting an additional warranty.

HP 10000 Series Rack Reference Guide

December 2002 (Second Edition)

Part Number 258200-002

Contents

About This Guide

Important Safety Information	vii
Symbols on Equipment	vii
Rack Stability.....	ix
Symbols in Text.....	ix
Getting Help.....	x
Technical Support	x
HP Website.....	x
Authorized Reseller.....	xi
Reader's Comments.....	xi

Chapter 1

Overview

10000 Series Racks.....	1-2
Rack Options	1-3
Delivery Considerations	1-5
Installation Overview.....	1-5
Installation Service.....	1-6

Chapter 2

Configuration Factors

Rack Configuration Software	2-1
Rack Builder Online Modes of Operation.....	2-2
Rack Builder Online Features	2-2
Component Placement	2-3
Additional Considerations	2-3
Optimum Environment	2-5

Space Requirements.....	2-5
Power Requirements.....	2-5
Grounding Requirements.....	2-6
Temperature Requirements.....	2-7
Airflow Requirements	2-8

Chapter 3

Preparing the Rack for Component Installation

Required Tools.....	3-2
Checking the Hardware.....	3-2
Removing the Rack Doors	3-3
Removing the Side Panels.....	3-7
Stabilizing the Rack	3-8
Standalone Racks.....	3-8
Multiple Racks.....	3-10
Server/Storage vs. Switching Configurations	3-10

Chapter 4

Installing Components

General Guidelines.....	4-2
Installation Overview	4-4
Using the Template	4-5
Inserting the Cage Nuts.....	4-6
Preparing and Installing the Rails	4-7
Preparing the Adjustable Fixed Rail.....	4-7
Installing the Adjustable Fixed Rail	4-8
Preparing the Sliding Rail.....	4-10
Installing the Sliding Rails.....	4-14
Preparing the Component.....	4-15
Adjustable Fixed Rails.....	4-15
Sliding Rails	4-16
Cable Management Arm Bracket	4-17
Installing the Component	4-18
Inserting the Component into the Rack	4-18
Attaching the Cable Management Arm	4-20
Routing the Cables.....	4-23
Rack Option Kits.....	4-26

Chapter 5
Specifications

Appendix A
Electrostatic Discharge

Grounding Methods A-2

Appendix B
Transportation Instructions

Transportation Methods B-1
 Air Transport B-1
 Land Transport B-2
 Sea Transport B-2
Delivery Services B-2
 Inside Rack Delivery Service B-2
 Expedited Rack Delivery Service B-3
 Shipping/Delivery Considerations B-4

Index

About This Guide

This guide provides step-by-step instructions for installation, and reference information for operation for the HP 10000 Series Rack.

Important Safety Information

Before installing this product, read the *Important Safety Information* document included with the server.

Symbols on Equipment

The following symbols may be placed on equipment to indicate the presence of potentially hazardous conditions:



WARNING: This symbol, in conjunction with any of the following symbols, indicates the presence of a potential hazard. The potential for injury exists if warnings are not observed. Consult your documentation for specific details.



This symbol indicates the presence of hazardous energy circuits or electric shock hazards. Refer all servicing to qualified personnel.

WARNING: To reduce the risk of injury from electric shock hazards, do not open this enclosure. Refer all maintenance, upgrades, and servicing to qualified personnel.



This symbol indicates the presence of electric shock hazards. The area contains no user or field serviceable parts. Do not open for any reason.

WARNING: To reduce the risk of injury from electric shock hazards, do not open this enclosure.



This symbol on an RJ-45 receptacle indicates a network interface connection.

WARNING: To reduce the risk of electric shock, fire, or damage to the equipment, do not plug telephone or telecommunications connectors into this receptacle.



This symbol indicates the presence of a hot surface or hot component. If this surface is contacted, the potential for injury exists.

WARNING: To reduce the risk of injury from a hot component, allow the surface to cool before touching.



These symbols, on power supplies or systems, indicate that the equipment is supplied by multiple sources of power.

WARNING: To reduce the risk of injury from electric shock, remove all power cords to completely disconnect power from the system.



Weight in kg
Weight in lb

This symbol indicates that the component exceeds the recommended weight for one individual to handle safely.

WARNING: To reduce the risk of personal injury or damage to the equipment, observe local occupational health and safety requirements and guidelines for manual material handling.

Rack Stability



WARNING: To reduce the risk of personal injury or damage to the equipment be sure that:

- The leveling jacks are extended to the floor.
 - The full weight of the rack rests on the leveling jacks.
 - The stabilizing feet are attached to the rack if it is a single-rack installation.
 - The racks are coupled together in multiple-rack installations.
 - Only one component is extended at a time. A rack may become unstable if more than one component is extended for any reason.
-

Symbols in Text

These symbols may be found in the text of this guide. They have the following meanings.



WARNING: Text set off in this manner indicates that failure to follow directions in the warning could result in bodily harm or loss of life.



CAUTION: Text set off in this manner indicates that failure to follow directions could result in damage to equipment or loss of information.

IMPORTANT: Text set off in this manner presents essential information to explain a concept or complete a task.

NOTE: Text set off in this manner presents additional information to emphasize or supplement important points of the main text.

Getting Help

If you have a problem and have exhausted the information in this guide, you can get further information and other help in the following locations.

Technical Support

In North America, call the HP Technical Support Phone Center at 1-800-652-6672. This service is available 24 hours a day, 7 days a week. For continuous quality improvement, calls may be recorded or monitored. Outside North America, call the nearest HP Technical Support Phone Center. Telephone numbers for worldwide Technical Support Centers are listed on the HP website, www.hp.com.

Be sure to have the following information available before you call HP:

- Technical support registration number (if applicable)
- Product serial number
- Product model name and number
- Applicable error messages
- Add-on boards or hardware
- Third-party hardware or software
- Operating system type and revision level

HP Website

The HP website has information on this product as well as the latest drivers and flash ROM images. You can access the HP website at www.hp.com.

Authorized Reseller

For the name of your nearest authorized reseller:

- In the United States, call 1-800-345-1518.
- In Canada, call 1-800-263-5868.
- Elsewhere, see the HP website for locations and telephone numbers.

Reader's Comments

HP welcomes your comments on this guide. Please send your comments and suggestions by e-mail to ServerDocumentation@hp.com.

Overview

As computer systems have evolved in size and complexity, managing them has become a critical concern. By centralizing your equipment in a HP 10000 Series rack, the efficiency and accessibility of your system can be increased dramatically.

The 10000 Series racks are designed to house rack-mountable products on industry-standard 19-inch wide rails. Using rack-mountable products allows you to decrease the footprint required to house your existing hardware while providing expansion capability.

Racks and rack-mountable components are typically described using U measurements. For example, one U is 44.45 millimeters (1.75 inches) high.

10000 Series Racks

The 10000 Series racks offer the following features:

- Interchangeable perforated front and split rear doors
- Cable access panel on rear door
- Perforated rack top with egress slot
- Graphite metallic color

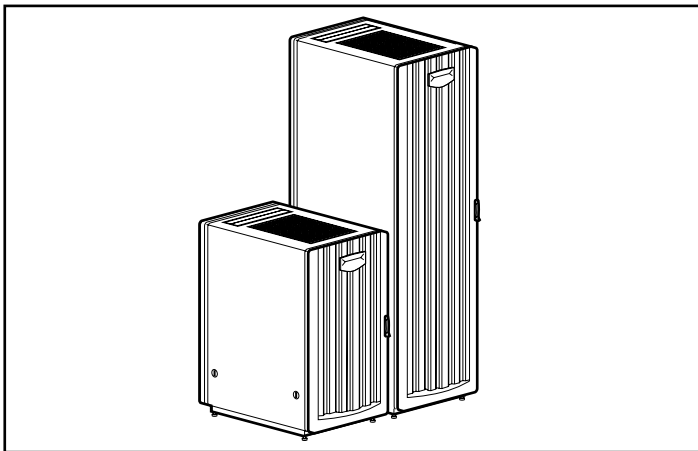

Figure 1-1: 10000 Series racks

Rack Options

In addition to the standard racks, HP also provides rack options to complement or complete your rack solution. The following list is only a sampling of the many rack option kits available. For more information, visit the HP website at www.hp.com.

Table 1-1: Rack Options

Option	Description
Side Panels Rack Option Kit	Enclosures for the sides of a rack
Stabilizer Rack Option Kit	Increases the stability of free-standing racks, or for use with modified side feet
Ballast Option Kit	Provides rack stability when heavy equipment is installed, removed, or accessed within the rack
Rack Option Baying Kit	Joins multiple racks of the same series, height, and depth
Rack Option Offset Baying Kit	Joins multiple racks of different series with the same height but different depths
Fan (110V/220V) Rack Option Kit	Enhances natural convection cooling by increasing the airflow in the rack
Ground Bonding Rack Option Kit	Reduces electromagnetic emissions that may be given off by electronic components operating within the rack
Monitor/Utility Shelf Rack Option Kit	Holds a monitor or other rack component
Server Console Switch	Programmable switch panel with connection hardware used to switch a keyboard, monitor, and mouse among multiple servers
Networking Cable and Recessed Rail Management Kits	Routes and organizes cables within the rack

continued

Table 1-1: Rack Options *continued*

Option	Description
Cable Management D-Ring Rack Option Kit	Helps with cable management
25-inch Rail Adapter Option Kit	Allows the inner rack rails to accommodate third-party rack options
1U Keyboard Drawer Option Kit	Holds and conceals a keyboard
100 Kilo Sliding Shelf Rack Option Kit	Allows easy access to various rack components
TFT5600 Rackmount Keyboard and Monitor (RKM)	Rack-mountable 1U keyboard and flat panel monitor on a drawer with room in the rear to add a switchbox
TFT5000R Flat Panel Monitor Rackmount	Rack-mountable 2U flat panel monitor
Depth Adjustable Fixed Rail Kit	Provides rails that can be adjusted to various depths
Shock Pallet Spares Kit	Transports configured racks
Rack Door Cushion Spares Kit	Provides padding between the rack unit and its front and rear doors

HP also offers several rack-mountable power products. For complete information about these products, see the HP website at www.hp.com.

Contact the nearest HP authorized reseller or service provider for information about ordering rack option kits. For the name of the nearest HP authorized reseller, see “About This Guide.”

Delivery Considerations

The following list is only a sampling of the many delivery considerations available. For more information, visit the Best Practices web page at www.hp.com.

When preparing to receive palletized racks, consider the following:

- The dock door at the receiving site has to accommodate the height and width of palletized racks.
- Do not lay a rack on its side because the sheet metal can become distorted.

Transport a rack as far into the building as possible while it is still on the pallet. Ideally, move the palletized rack to its final destination before removing the rack from the pallet or removing any of the packaging.

Installation Overview

The following is the recommended sequence of events for the most efficient installation of your rack and components.

1. Install the Rack Builder Online software from the HP website. Using the Rack Builder Online software, plan the rack component location and installation sequence.
2. Select a location to set up your rack. This should be as close as possible to the permanent site for your rack.
3. Remove the packaging from the rack and verify the hardware contents.
4. Remove any doors and panels from the rack to provide easy access.
5. Stabilize the rack.
6. Bay multiple racks together.
7. Install products such as Power Distribution Units (PDUs) or switch boxes in sidewall locations.
8. Install products such as Uninterruptible Power System (UPS) units starting from the bottom of the rack.

9. Install the appropriate support rails and/or tray for the first rack-mountable component.
10. Install the first individual component.
11. Attach a cable management arm, if required.
12. Attach the appropriate cables and power cords to the component, being sure to adhere to all cautions and warnings.
13. Install the remaining components in the appropriate sequence.
14. Reinstall any doors and panels.
15. Power up and configure the system.

Installation Service

In the United States, HP can make arrangements to have your rack system installed by qualified guaranteed service providers. This installation service covers the entire hardware installation sequence, from unpacking the components to routing cabling and running a test of the system. For more information on HP support, see “About This Guide.”

Configuration Factors

Before populating your new rack, it is important to plan the placement of each component. Factors of each component, such as weight, accessibility, power, temperature, and airflow requirements, affect installation order and component placement in the rack.

Rack Configuration Software

To help you plan your rack configuration more efficiently, HP provides Rack Builder Online, the browser-based rack configuration tool. The latest version of the software is available at www.hp.com.

Rack Builder Online Modes of Operation

The Rack Builder Online software has two modes of operation:

- **Help Me Build It Mode**—Includes a simple interview session to help determine your rack and component needs, as well as the necessary power products and rack assembly devices needed to complete the final rack assembly.
- **Let Me Build It Mode**—Lets you select the individual devices that are required for your rack configuration.

Rack Builder Online Features

The Rack Builder Online software offers the following features:

- **Multiple-Rack Configuration**—Allows up to six racks to be viewed and configured on-screen in one session.
- **Graphics**—Uses graphical representations of the systems to illustrate the U height that each component occupies.
- **Labeling**—Aids in rack maintenance and configuration by allowing individual racks and components within a rack to be labeled.
- **Drag & Drop**—Allows the graphics of devices in a multiple-rack configuration to be **dragged and dropped** between racks.
- **Reports**—Provides reports on rack configuration labeling and rack suite graphics for configurations that include multiple racks.
- **Third-Party Support**—Allows you to define and add third-party products.

If you are planning a new rack, use Rack Builder Online to view your rack as you build it. Then print out a report and use it as your shopping list. After your rack configuration is in place, use Rack Builder Online to assist you in maintenance and upgrades.

See the documentation accompanying the software utilities for installation and use of the software programs.

Component Placement

The following rules apply to the physical placement of components in the rack:

- **Weight**—Sort all components by weight, placing the heaviest components at the bottom of the rack.
- **Server Console Switch**—Position the switch box on the side of the rack above the keyboard, or mount it behind the keyboard.
- **CRT Monitor**—Position the monitor topmost within the rack.
- **Rack-Mountable Flat Panel Monitor**—Select a position to accommodate the desired viewing height (a minimum of 4Us above the keyboard tray).
- **Balance**—Be sure to balance the weight load between racks and place the heaviest components at the bottom of the rack. For example, if you have several UPS units and several servers, do not put all of the UPS units into one rack—distribute them evenly in the bottom positions of each rack.

Additional Considerations

The following are additional items to consider, based on your specific rack configuration:

- **Power**—If a UPS is installed, do not exceed its output rating. Be sure to review the installation instructions provided with each component for important cautions and warnings.
- **PDUs**—Install PDUs before installing other components.
- **Height**—The height of the rack and of rack-mountable components is measured in U increments. When you are configuring your rack installation, remember that the total U measurement of the components you want to install cannot exceed the stated U height of the rack.
- **Keyboard**—The rack keyboard requires installation of a 1U Keyboard Drawer Rack Option Kit.
- **Monitor**—The monitor requires installation of a Monitor/Utility Shelf Rack Option Kit unless you are using a rack-mountable flat panel monitor.

- **Server Console Switch**—If a switch box is configured, use the CPU-to-Switch cable included with the server. The standard distance between the switch box and the keyboard, monitor, and/or mouse can vary by 3-, 7-, 12-, 20- and 40-foot lengths. Optional Plenum-rated KVM cables are available in 20-foot and 40-foot lengths.

NOTE: National Electrical Regulations governing the installation of building wiring require that an appropriate cable, meeting fire-safety standards, must be used any time cabling is routed:

- Through an overhead drop-ceiling
- Under a computer room's raised flooring
- From room to room
- From floor to floor

Be sure that the cable jacket or sleeving is made of material that does not burn easily and does not exude toxic fumes when exposed to heat. Be sure that the cable you have selected is appropriate for your installation site. If you require a U.S. plenum-rated (CL2P) cable, please contact your local HP authorized reseller to obtain the following options:

- 149363-B21—20-foot plenum cable
 - 149364-B21—40-foot plenum cable
- **Baying Option Kits**—The number of baying kits needed to join a series of racks is one less than the number of racks in the suite. Each baying kit supplies parts to bay two cabinets on 600 millimeters (24 inches) center line spacing.
 - **Side Panels**—Only one set of side panels is required for each row of bayed racks.
 - **Stabilizing Feet**—A stand-alone rack requires stabilizing feet.

Optimum Environment

Specific requirements for space, power, temperature, and airflow must be met to provide optimum performance with minimum maintenance for your rack environment.

Space Requirements

When deciding where to place your rack:

- At least 122 centimeters (48 inches) of clearance is needed all the way around the pallet and above the rack to allow the removal the packing materials.
- At least 86 centimeters (34 inches) of clearance is needed in front of the rack to allow the door to open all the way.
- At least 75 centimeters (30 inches) of clearance is needed in the rear of the rack to provide access to components.
- At least 38 centimeters (15 inches) of clearance is needed around a power supply to facilitate servicing.

Power Requirements



WARNING: To reduce the risk of personal injury, fire, or damage to the equipment, do not overload the AC supply branch circuit that provides power to the rack. Consult the electrical authority having jurisdiction over your facility wiring and installation procedures.

When planning for power distribution requirements for your rack configuration:

- The power load must be balanced between available AC supply branch circuits.
- The overall system AC current load must not exceed 80 percent of the branch circuit AC current rating.

- If a UPS is used, the load should not exceed 80 percent of the UPS's marked electrical current rating.



CAUTION: To reduce the risk of damage to the equipment, verify that all AC Voltage Selector Switches are set correctly to match your local AC line voltage (115V or 230V). If the AC Voltage Selector Switches are not properly set, your components will be damaged when power is applied.

The installation of this equipment shall be in accordance with local/regional electrical regulations governing the installation of Information Technology Equipment by licensed electricians. This equipment is designed to operate in installations covered by the National Electric Code (ANSI/NFPA-70, 1993) and the code for Protection of Electronic Computer/Data Processing Equipment (NFPA-75, 1992).

For electrical power ratings on options, refer to the product's rating label or user documentation supplied with that option.

Grounding Requirements

For proper operation and safety, all powered rack-mountable components are required to be properly grounded in accordance with (NFPA-70, 1993), Article 250. All power distribution devices, branch wiring, and receptacles must be listed as grounding-type devices.

When using power strips for electrical distribution, make sure that ground integrity is maintained for each connection made. Plug each component into a reliably grounded outlet.



WARNING: To reduce the risk of electric shock or damage to your equipment, do not disable the power cord grounding feature. This equipment is designed to be connected to a grounded (earthed) power outlet that is easily accessible and located as close as possible to the equipment. The grounding plug is an important safety feature.

Temperature Requirements

For safe and reliable operation of equipment, locate the system in a well-ventilated, climate-controlled environment.

The HP Maximum Recommended Ambient Operating Temperature (TMRA) for most server products is 95°F (35°C). Therefore, the temperature in the room where the rack is located should not exceed 95°F (35°C).

The operating temperature inside the rack is always higher than the room temperature and is dependent on the configuration of equipment in your rack. Check the TMRA for each piece of equipment before installation.

The maximum internal rack temperature for your configuration should not exceed the values in the following table.

Table 2-1: Rack Internal Temperature Maximums

Equipment Included	Maximum Internal Rack Temperature
HP rack-mountable servers	95°F/35°C
HP rack-mountable options	104°F/40°C
HP PDUs	122°F/50°C
Other manufacturers' options	See other manufacturers' specifications



CAUTION: To reduce the risk of damage to the equipment when installing third-party options:

- Make sure that the option equipment does not impede airflow to the rack-mountable products already installed in the rack or increase the internal rack temperature beyond the HP specified maximum rating.
- Make sure that the manufacturer's Maximum Recommended Ambient Operating Temperature for the option equipment is not exceeded when the option equipment is installed in a HP rack.

Airflow Requirements

HP rack-mountable products typically draw in cool air through the front and exhaust warm air out through the rear of the rack. The front door of the rack, therefore, must be adequately ventilated to allow ambient room air to enter the rack, and the rear door must be adequately ventilated to allow the warm air to escape the rack. Do not block the ventilation apertures.

Fan Kits

If additional cooling is required, fan kits can be used to draw heated air from the rack and exhaust it out through the top.

Blanking Panels

If the front of the rack is not completely filled with components, the remaining gaps between the components can cause changes in the airflow, which can adversely affect cooling within the rack. Cover these gaps with blanking panels.

Preparing the Rack for Component Installation

This chapter discusses the following topics:

- Required tools
- Checking the hardware
- Removing the rack doors
- Removing the side panels
- Stabilizing the rack
 - Standalone racks
 - Multiple racks
- Server/Storage vs. switching configurations

Required Tools

You need the following tools to install your rack components:

- Flat-bladed screwdriver
- Phillips screwdrivers—#1, #2, and #3
- Torx screwdrivers—T-10, T-15, T-25, and T-30
- Adjustable wrench
- Allen wrench
- Cage nut fitting tool (included with original rack hardware kit)

For comfort and efficiency while setting up your rack and installing the components, use battery-powered screwdrivers.

Checking the Hardware

After unpacking the rack and its components, locate the HP Rack Kit Components List that was shipped with your rack. Verify that you received all listed components.

You will typically have extra fasteners after completing your rack configuration and component installation.

IMPORTANT: Retain the extra fasteners for future use.

Removing the Rack Doors

To provide access to all sides of the rack while you are installing the various components, first remove the rack doors. If your rack has side panels, also remove them before installing mounting brackets and other hardware.

To remove the rack front door:

1. Unlock the door (1) and press the handle release button (2). The handle pops out.
2. Lift the handle up and out to open the door (3).

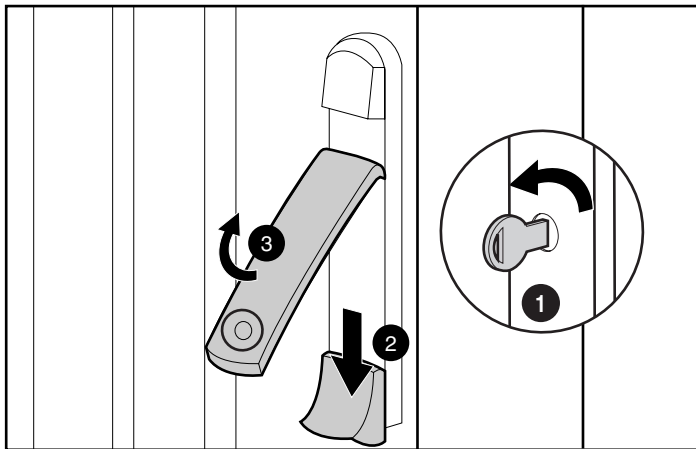

Figure 3-1: Opening the front door

3. Lift up the top hinge pin (1).
4. Tilt the door out and lift to remove it from the bottom hinge bracket (2).
5. Lift the door out and away from the rack (3). Store the door in an upright position, taking care to protect it from damage.

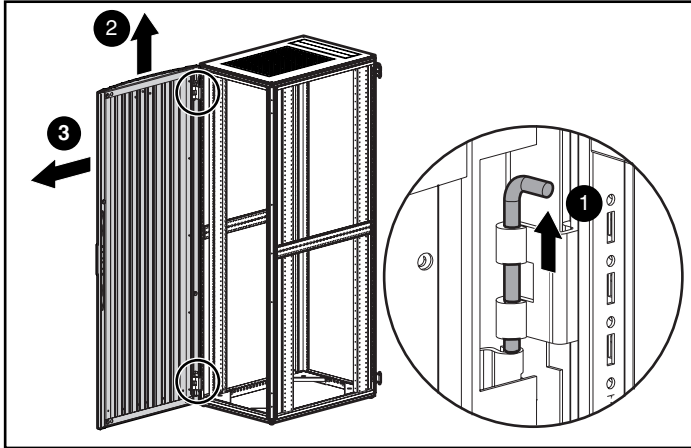

Figure 3-2: Removing the front door

To remove the rack rear doors:

1. Rotate the handle to the right (1).
2. Pull the handle to open the doors (2).

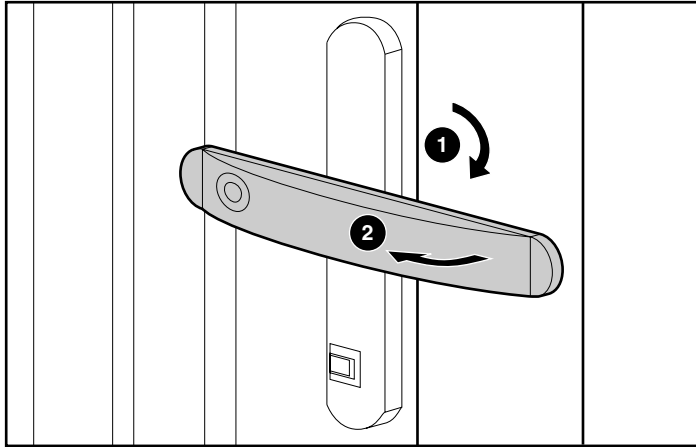

Figure 3-3: Opening the rear doors

3. Open the hinge brackets by pulling up on the top hinge and down on the bottom hinge for each door (1).
4. Lift the rear doors off of the hinge brackets and remove them from the rack (2). Store the doors in an upright position, taking care to protect them from damage.

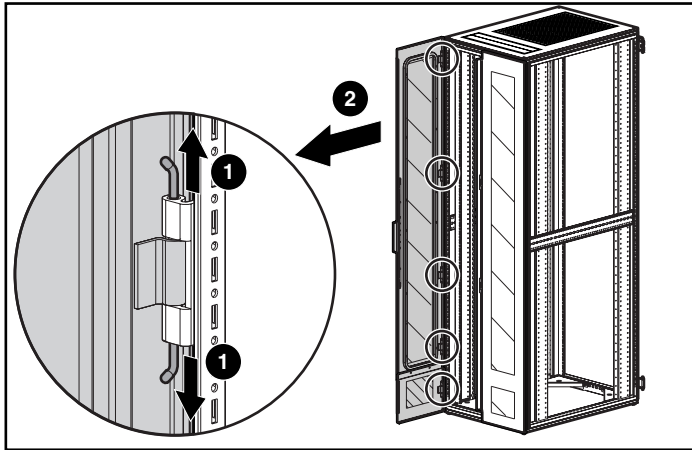

Figure 3-4: Removing the rear doors

Removing the Side Panels

To remove the side panels:

1. Unlock the two side panel locks securing the side panels to the rack (1).
2. Lift each side panel up to unhook it from the hangers bolted on the rack frame (2).
3. Remove each side panel from the rack (3). Store the panels in an upright position, taking care to protect them from damage.

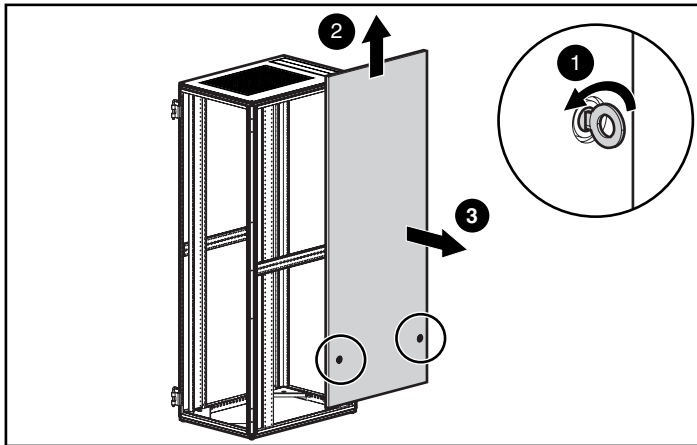

Figure 3-5: Removing the rack side panels

Instructions for replacing the side panels are given in the *Side Panel Rack Option Kit Installation Instructions* card.

Stabilizing the Rack



WARNING: The rack allows you to stack computer components on a vertical rather than a horizontal plane. To reduce the risk of personal injury or damage to the equipment, you must follow these instructions carefully and heed all cautions and warnings throughout the installation instructions.

Standalone Racks

If you are installing a single (standalone) rack, make sure that the rack is level and that stabilizing feet have been attached, before installing the components. If an unstable rack is loaded with components, it can become unbalanced and may tip over.

Leveling Feet

The leveling feet, located beside each caster on the rack, unscrew and extend to the floor, resting in leveling-feet bases provided with your rack. These feet support the rack and help compensate for uneven surfaces.

After positioning the rack in its final location, use an adjustable wrench to extend the leveling feet into the bases until the weight of the rack is fully on the feet and feet bases, not the casters. This stabilizes the rack for installation of your components.



CAUTION: To reduce the risk of damage to the casters, make sure that the full weight of the rack rests on the leveling feet, and not on the casters. The casters are designed **only** as an aid in moving the rack into position. They are not designed to support the weight of the rack and may become damaged if relied on to support the rack.

Stabilizing Feet



WARNING: To reduce the risk of personal injury, you must attach HP Series rack stabilizing feet to all standalone (non-bayed) racks.

The Stabilizer Rack Option Kit contains three full-size and two modified stabilizing feet.

- The full-size stabilizing feet are for standalone racks. Attach one stabilizing foot to the front and one to each side of the rack. Stabilizing feet are not required on the back of a standalone rack.
- The modified stabilizing feet are for bayed racks. Attach one modified foot to the front of the rack when you place it between third-party racks.

NOTE: The Stabilizer Rack Option Kit components come standard with each 10622 rack.

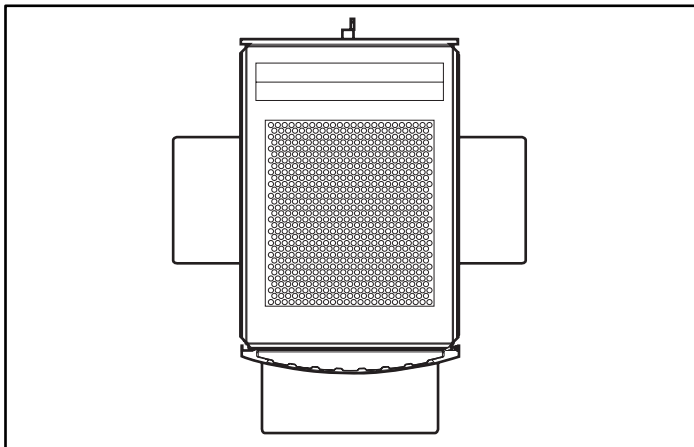

Figure 3-6: Full-size stabilizing feet attached (top view)

Multiple Racks

Increasing space and stability, 10000 Series racks can be bayed together by installing the Rack Option Baying Kit or the Rack Option Offset Baying Kit, depending on the series, height, and depth.

- **Rack Option Baying Kit**—Joins multiple racks of the same series, height, and depth.
- **Rack Option Offset Baying Kit**—Joins multiple racks of different series with the same height but different depths.

Observe the following tips when using multiple-rack configurations:

- Stabilizing feet are optional with bayed racks.
- Modified feet should be used with bayed racks.
- The number of baying kits needed is one less than the total number of racks.
- Position and install either baying option kit before populating the racks with components.
- Racks from different series can be bayed together as long as they are the same height.

Server/Storage vs. Switching Configurations

The 10000 Series rack offers interchangeable front and rear doors that allow the rack to be used in server/storage or switching applications. The 10842 rack arrives in a server/storage configuration with internal mounting rails that are front-justified, providing the customer greater room in the rear of the rack for cable management.

Installing Components

IMPORTANT: It is strongly recommended that you configure your rack using the Rack Builder Online software before beginning the installation process.

This chapter discusses the following topics:

- General guidelines
- Installation sequence
- Using the template
- Inserting the cage nuts
- Preparing and installing the rails
- Preparing the component
- Installing the component
 - Inserting the component into the rack
 - Attaching the cable management arm
 - Attaching the cables
 - Routing the cables

General Guidelines



WARNING: To reduce the risk of personal injury, always be sure that the rack is adequately stabilized before extending a component outside the rack. A rack may become unstable if more than one component is extended for any reason. Extend only one component at a time.



WARNING: To reduce the risk of personal injury or damage to the equipment, always load the heaviest item first from the bottom of the rack up. This makes the rack bottom-heavy and helps prevent the rack from becoming unstable. See Chapter 2, “Configuration Factors,” for more information about the placement of rack-mountable components.



WARNING: To reduce the risk of personal injury or damage to the equipment, be sure that:

- The leveling jacks are extended to the floor.
 - The full weight of the rack rests on the leveling jacks.
 - The stabilizing feet are attached to the rack if it is a single-rack installation.
 - The racks are coupled together in multiple-rack installations.
 - Only one component is extended at a time. A rack may become unstable if more than one component is extended for any reason.
-



CAUTION: To reduce the risk of damage to the equipment when installing third-party options:

- Be sure that the option equipment installed does not impede airflow to the rack-mountable ProLiant servers or increase the internal rack temperature beyond the specified maximum rating.
 - Be sure that the option equipment installed does not exceed the Manufacturer’s Maximum Recommended Ambient Operating Temperature.
-

Observe the general guidelines when loading your components:

- For detailed instructions on installing a specific component or third-party hardware, see the user documentation that was shipped with the component.
- See Appendix A, “Electrostatic Discharge,” before installing components into the rack.
- Use the configuration prepared with the Rack Builder Online software utility as a guideline for installing components.
- Load the heavier components first from the bottom of the rack up.
- Be sure to balance the weight load between bayed racks. For example, if you have several UPS units and several servers, do not put all of the UPS units into one rack. Instead distribute them evenly in the bottom positions of each rack.
- Allow a minimum clearance of 76 centimeters (30 inches) between the wall and the rear of the rack to provide adequate access for installation and service.

Installation Overview

NOTE: The stabilizer feet should be installed prior to any component installation.

IMPORTANT: The installation instructions below are for standard installations. For specific installation instructions, refer to the documentation included with your component.

The following steps outline the sequence for installing rack-mountable components in a rack. You should install zero U devices first, such as PDUs, switch boxes, and so on.

1. Use the template to measure and mark the rack for correct placement of the installation hardware.
2. Install the cage nuts into the rack.
3. Prepare and install the adjustable fixed and/or sliding rails.
4. Prepare the component for mounting in the rack.
5. Install the component into the rack and secure it.
6. Attach the cable management arm to the rack and then to the component.
7. Attach any cables and power cords, being sure that you adhere to all cautions and warnings contained in the individual component installation instructions.
8. Remove the cable access panel and route the cables.

Using the Template

Use the template that was shipped with your rack-mountable component to mark the location of the mounting hardware on the mounting rails of the rack.

1. Push back the tabs (marked ★) in the top of the template and place them in the correct holes in the mounting rails.
2. Match up the hole pattern indicated on the sides of the template with the hole pattern in the mounting rails.

Make sure you begin measuring in the correct place. If a rack component is already installed immediately below the planned position of the new component, place the template on top of the previously installed component and against the front mounting rails.

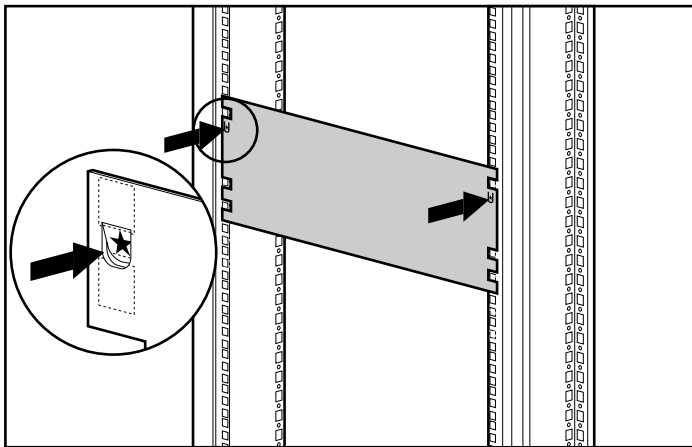

Figure 4-1: Measuring with the template

3. Use the front of the template to mark the attachment points for rack-mounting brackets, rails, components, or cage nuts on the front of the rack.
4. Use the back of the template to mark the attachment points for rack-mounting brackets, rails, components, or cage nuts on the back of the rack.

Inserting the Cage Nuts

Use the cage nut insertion tool to install the cage nuts on the inside of the mounting rails.

1. Hook the bottom lip of the cage nut in the square rail perforation.
2. Insert the tip of the insertion tool through the perforation and hook the top lip of the cage nut.
3. Use the insertion tool to pull the cage nut through the hole until the top lip snaps into position.

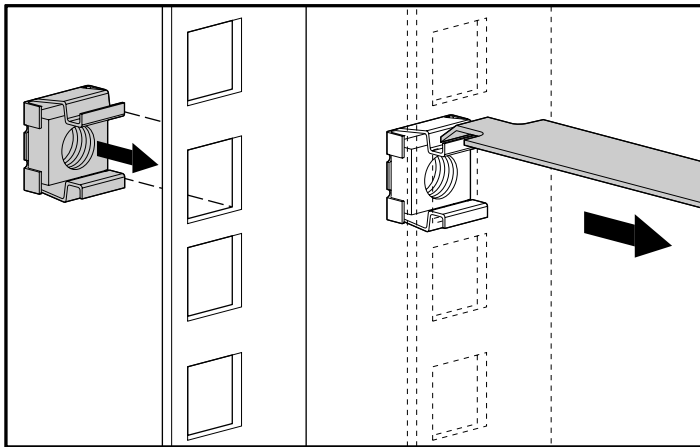

Figure 4-2: Inserting cage nuts

Preparing and Installing the Rails

IMPORTANT: The installation instructions below are for standard installations. For specific installation instructions, please refer to the documentation included with your component.

There are two types of rack-mountable rails:

- Adjustable fixed rails
- Sliding rails

Preparing the Adjustable Fixed Rail.

Components mounted with adjustable fixed rails are typically designed to slide into the rack one time for initial installation.

1. Loosen the wing nuts (1) and extend the rail-mounting brackets to the desired length (2).

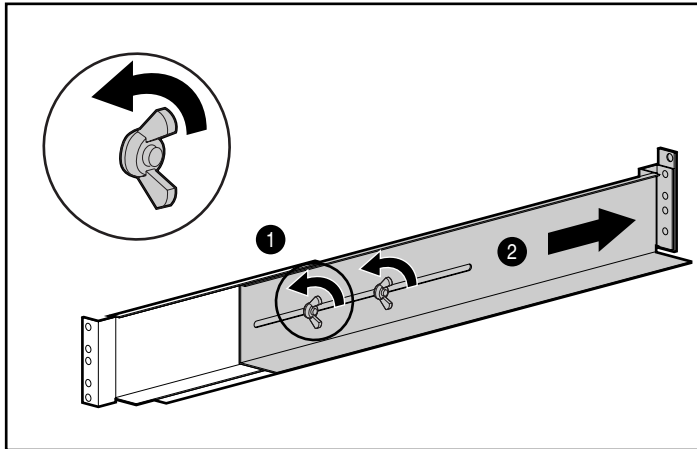

Figure 4-3: Adjusting the fixed rails

2. Tighten the wing nuts slightly to stabilize the rail-mounting brackets during installation.

Installing the Adjustable Fixed Rail

1. Insert at least one screw through the rail-mounting bracket, securing the adjustable fixed rail to the front of the rack.

NOTE: After installing your components, insert at least one more screw into each adjustable rail for additional support.

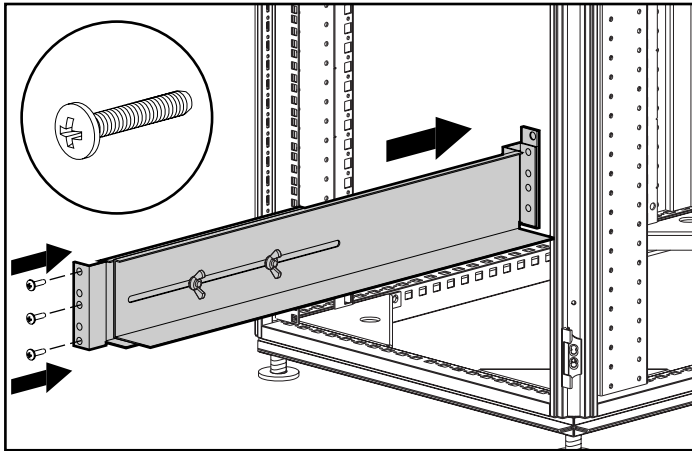

Figure 4-4: Securing the adjustable fixed rail to the front of the rack

2. Insert at least one screw through the rail-mounting bracket and into the cage nuts installed earlier, securing the adjustable fixed rails to the rear of the rack.

NOTE: After installing your components, insert at least one more screw into each adjustable rail for additional support.

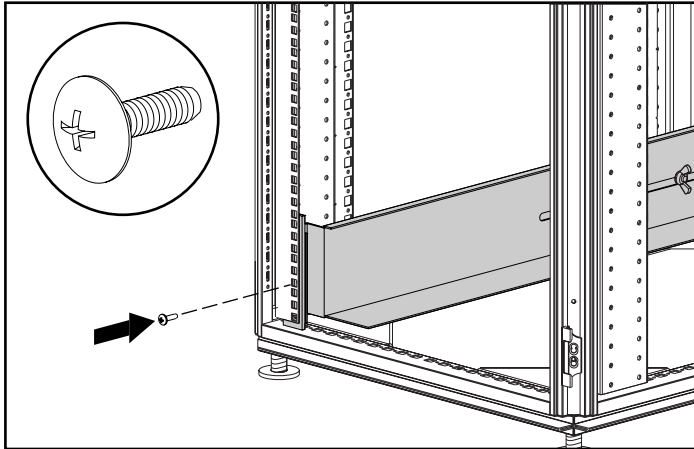

Figure 4-5: Securing the adjustable fixed rail to the rear of the rack

3. Retighten the wing nuts on the adjustable rails.

The adjustable fixed rails are now ready for installation of your components.

Preparing the Sliding Rail

Components mounted with this type of rail are designed for frequent accessibility and/or maintenance.

1. Extend the component rail until the component rail release latch clicks (1).
2. Hold down the component rail release latch (2) and completely remove the component rail from the sliding rail assembly.

NOTE: You will attach the component rail to the component before you insert the unit into the rack.

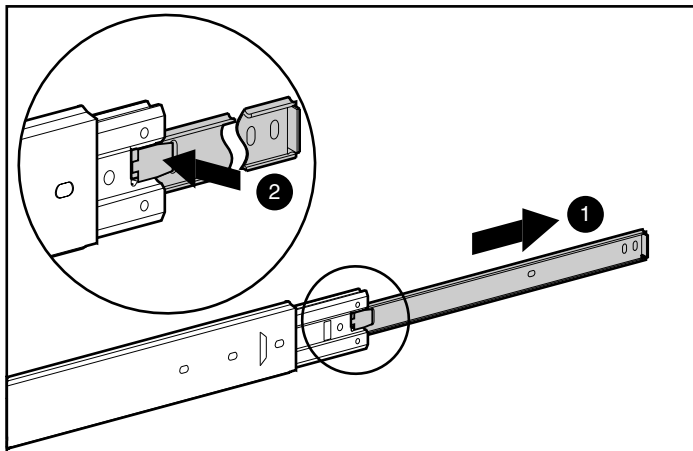

Figure 4-6: Removing the component rail from the sliding rail assembly

3. After removing the component rails, attach the sliding rail assembly to the rack-mounting brackets. Note the orientation of the rack-mounting brackets:
 - a. The front flange (1) has alignment tabs.
 - b. The back flange (2) is designed to install flush against the rack.

NOTE: There are eight screw holes in the standard rack-mounting brackets. All of the screw holes may not be used, depending on the component you are installing. Check the documentation shipped with your component to see which screws need to be installed.

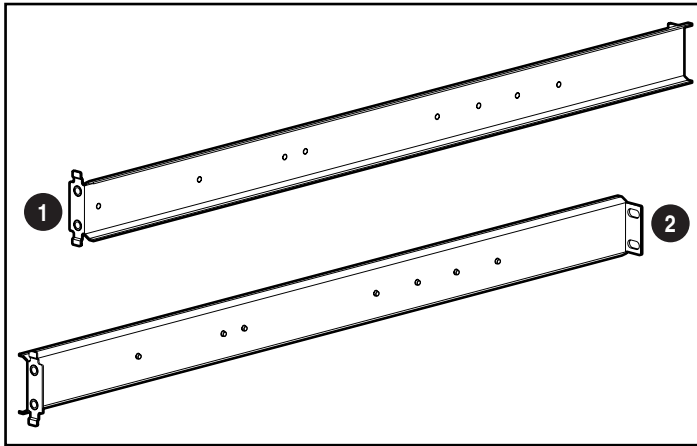

Figure 4-7: Rack-mounting brackets

4. Note the orientation of the sliding rail assembly:
 - a. The front of the sliding rail assembly (1) allows the inner slide to move forward on ball bearings.
 - b. The back of the sliding rail assembly (2) has a stop for the inner slide.

NOTE: While matching fronts, lay one rack-mounting bracket and one sliding rail assembly together so that the screw holes are aligned.

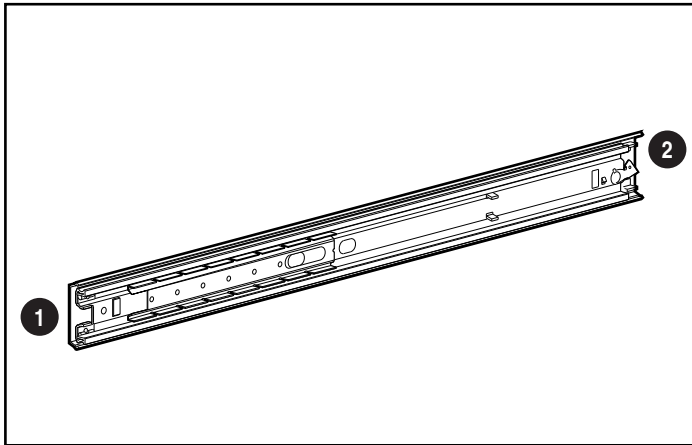

Figure 4-8: Orienting the sliding rail assembly

5. Extend the inner slide in the sliding rail assembly until the screw holes in the rack-mounting bracket and the sliding rail assembly are aligned (1). Secure the sliding rail assembly to the rack-mounting bracket by inserting one 8-32 \times 3/8 screw into each of the three exposed holes, two near the rear and one near the front of the sliding rail assembly.
6. Adjust the inner slide until you can access another screw hole (2) and insert one 8-32 \times 3/8 screw.
7. Adjust the inner slide again and insert the last 8-32 \times 3/8 screw (3) into the exposed hole.

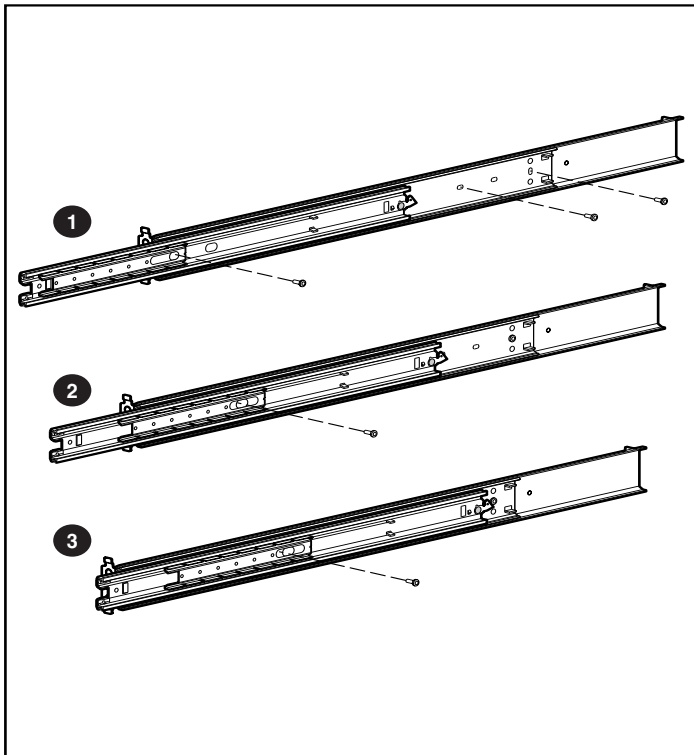

Figure 4-9: Attaching the sliding rail assembly to the rack-mounting brackets

The sliding rails are now ready for installation.

Installing the Sliding Rails

1. Align and secure the front of the sliding rail to the front of the rack with two M6 × 16 screws.

NOTE: The tabs on the front of the sliding rails help you align them correctly with the mounting rails.

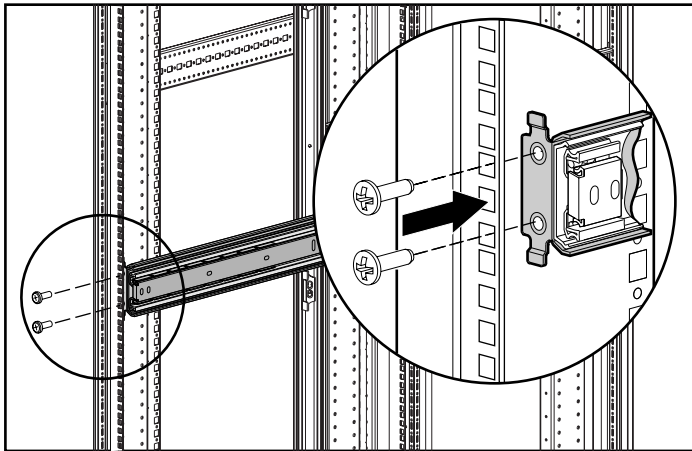

Figure 4-10: Securing the front of the sliding rail

2. Align the rear of the sliding rail with the cage nuts on the rear of the rack and secure with two M6 × 16 screws.

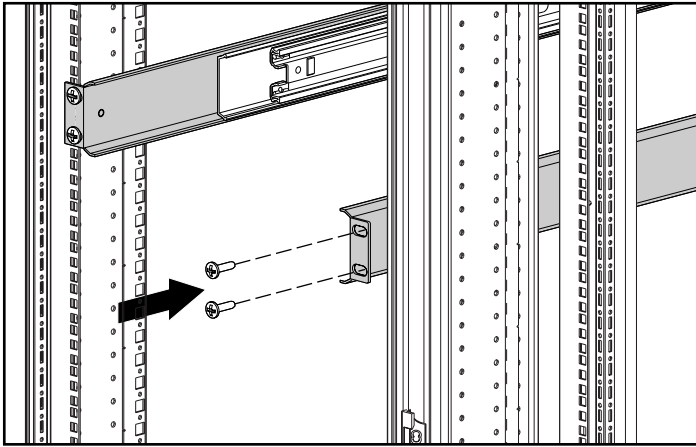

Figure 4-11: Securing the rear of the sliding rail

Preparing the Component

The following are general instructions for installing a typical rack-mountable component. See the documentation that was shipped with each component for complete installation instructions.

Adjustable Fixed Rails

If the component mounts with fixed rails, typically there is nothing additional to install on the component. The component slides into place along the rails you installed in the rack.

Sliding Rails

For a sliding rail installation, you need to install the component rails on the component before you can insert it into the rack.

1. Locate the component rails that you set aside when they were removed from the sliding rails earlier.
2. Use three 8-32 \times 3/8 screws to install each component rail on the side of the component.

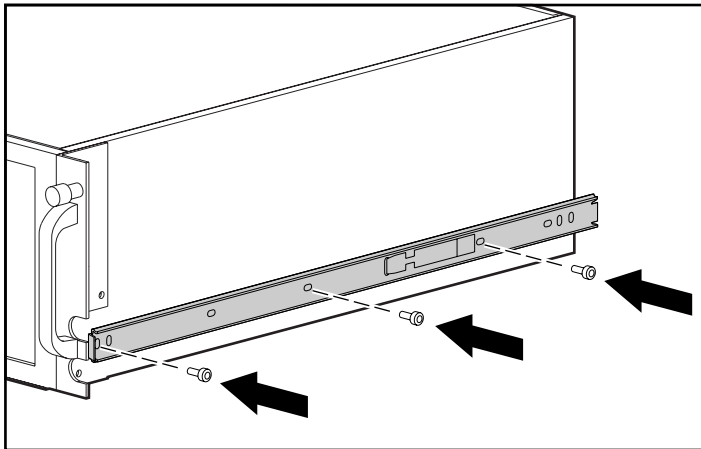

Figure 4-12: Attaching the component rails to the component

Cable Management Arm Bracket

If the component uses a cable management arm, use two 6-32 × 1/4 screws to attach the bracket that supports the cable management arm to the component.

NOTE: The cable management arm is installed after the component is installed into the rack.

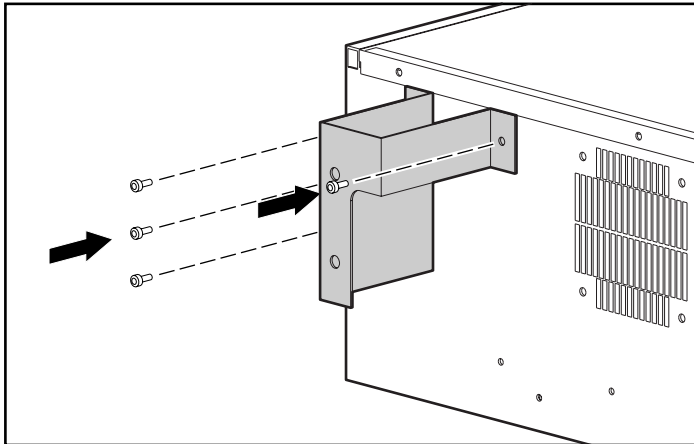

Figure 4-13: Attaching the cable management arm bracket to the component

Installing the Component

After all rack-mounting hardware has been installed on the component you can insert it into the rack.



WARNING: Components can be very heavy. To reduce the risk of personal injury or damage to the equipment:

- Remove all pluggable power supplies and modules to reduce the weight of the product before lifting it.
 - Observe local occupational health and safety requirements and guidelines for manual material handling.
 - Get help to lift and stabilize the product during installation or removal, especially when the product is not fastened to the rails.
 - When installing the product into or removing the product from the rack, the product is unstable when not fastened to the rails.
-

Inserting the Component into the Rack

IMPORTANT: Read and adhere to the cautions and warnings in this section.

To install a component into the rack:

1. Be sure that you have an adequate number of individuals or a mechanical lifting device to help you install the component into the rack.
2. Fully extend the sliding rails.
3. With the unit well supported, lift it up and align the component rails on the component with the sliding rails secured to the rack.

4. Press in the component rail release latches on either side of the component and slide the unit all the way back into the rack.

NOTE: The first time you slide the unit into the rack, you may have to apply some pressure to loosen the ball bearings. After that, the ball bearings should slide easily.

5. Using the cage nuts, tighten the thumbscrews on the front of the unit to secure it to the rack.

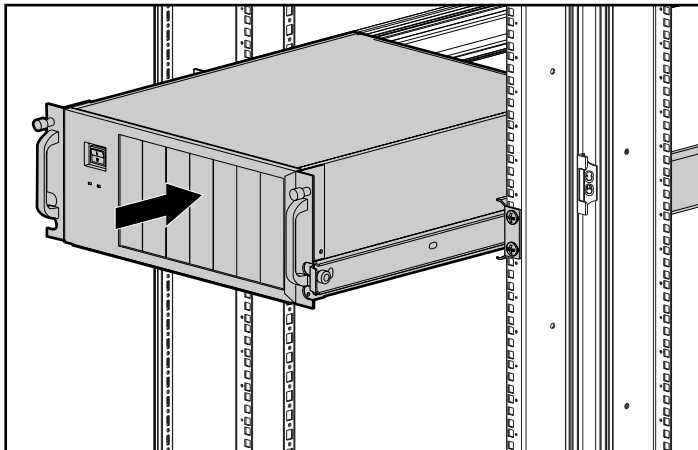

Figure 4-14: Inserting the component into the rack

Attaching the Cable Management Arm

1. Extend the cable management arm and bend the hinged bracket to the right.
2. Use two M6 × 12 Phillips screws to attach the cable management arm to the bracket you installed on the component earlier.

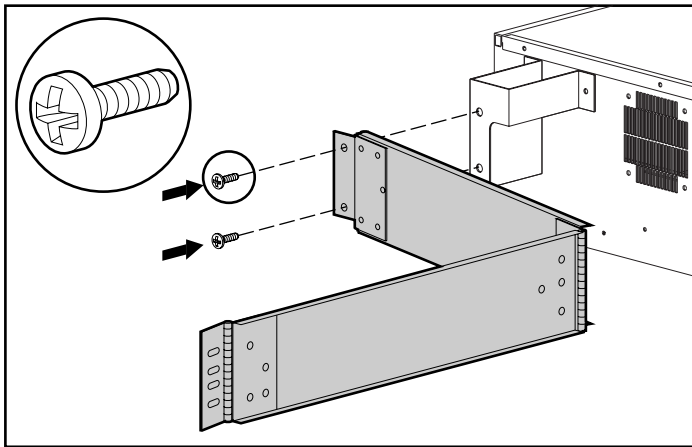

Figure 4-15: Attaching the cable management arm to the bracket

3. Align the screw retaining plate behind the rack-mounting rail at the rear of the rack and attach the cable management arm to the rail with two 10-32 \times 5/8 screws.

NOTE: As you slide the unit in and out of the front of the rack, the cable management arm collapses and extends so that the cables remain connected to the unit and stay untangled.

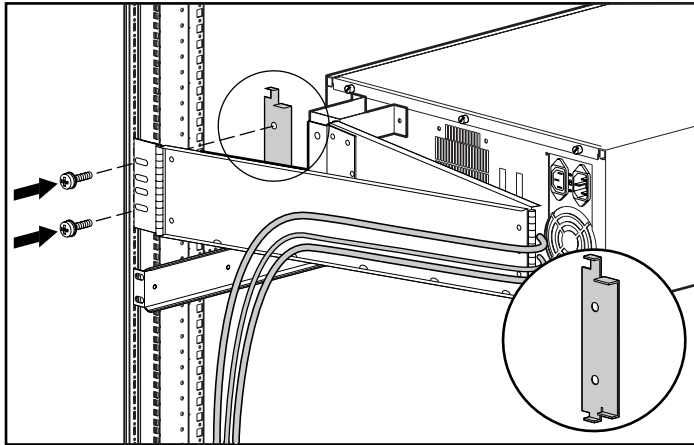

Figure 4-16: Attaching the cable management arm to the rack

4. Secure any cables that you attach to the component to this arm.

Attaching the Cables

1. Attach any cables that need to be connected to the component.
2. To attach the power cord:
 - a. Remove the label covering the AC power outlet.
 - b. Set the input voltage selection switch to the appropriate position.
 - c. Attach the AC power cord to the unit.

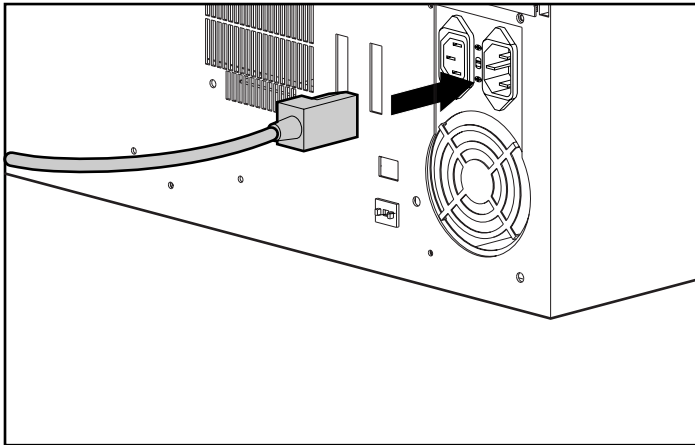

Figure 4-17: Attaching the AC power cord to the component

Routing the Cables

1. Bundle the cables with the cable arm extended, including the power cord.
2. Secure the cables to the cable management arm with the fasteners provided.

NOTE: Leave enough slack in the cables so that you can bend the cable management arm easily.

3. Route the bundled cables over the top of the cable management arm and down the cable conduit, if present.

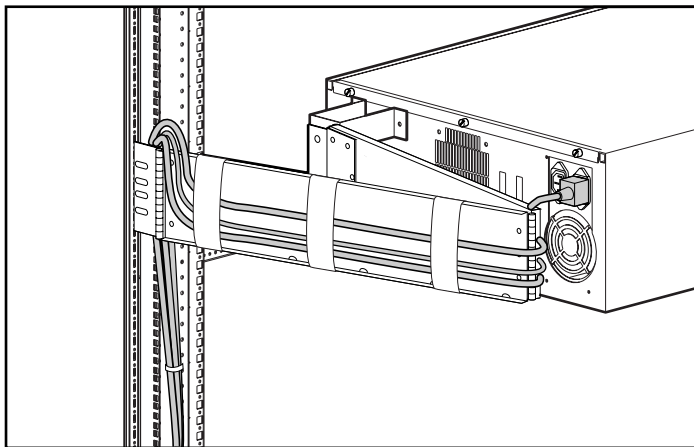

Figure 4-18: Routing the cables for server/storage applications

4. Remove the cable access panel, if present.

5. To remove the cable access panel:

NOTE: The cable access panel can be removed from the left rear door.

- a. Rotate the handle to the right.
- b. Pull the handle to open the doors (1).
- c. Release the cable access panel hinges (2) and then unscrew the two fasteners (3). Retain the fasteners and hinge brackets for later steps.
- d. Remove the cable access panel from the hinge bracket (4). Store the panel in an upright position, taking care to protect it from damage.

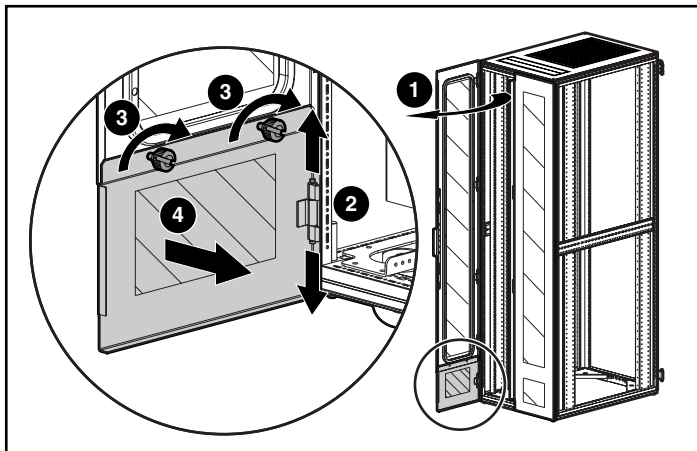

Figure 4-19: Removing the cable access panel



WARNING: To reduce the risk of electrical shock or damage to the equipment:

- Do not disable the power cord grounding plug. The grounding plug is an important safety feature.
 - Plug the power cord into a grounded (earthed) electrical outlet that is easily accessible at all times.
 - When using an optional power distribution device, make sure that the ground integrity is maintained for each connection by plugging each component into a reliable grounded outlet.
-



CAUTION: To reduce the risk of damage to the equipment, verify that all AC Voltage Selector Switches are set to match your local AC line voltage (115V or 230V). If the AC Voltage Selector Switches are not properly set, your components will be damaged when power is applied.

6. After all the cables and power cords have been routed to their power destinations, connect the power cords to a main power switch such as a properly rated power distribution unit.

NOTE: If you are not using a power distribution unit, route the power cords directly to a properly rated and grounded AC wall or floor outlet.

Rack Option Kits

The following rack option kits are available for use with the HP 10000 Series rack:

- Baying Rack Option Kit
- Blanking Panel Rack Option Kit.
- 25-inch Rail Adapter Option Kit
- Cable Management D-Ring Rack Option Kit
- Fan (110V/220V) Rack Option Kit
- Ground Bonding Rack Option Kit
- Side Panel Rack Option Kit
- Stabilizer Rack Option Kit

For complete information see the HP website at www.hp.com.

Specifications

Table 5-1: Model 10622

Dimensions		
Cabinet size	Height	1092 mm (43 inches)
	Depth	1016 mm (40 inches)
	Width	610 mm (24 inches)
Shipping size (with packing materials)	Height	1346 mm (53 inches)
	Depth	1219 mm (48 inches)
	Width	813 mm (32 inches)
Weight		
Operating		80 kg (176 lbs)
Shipping		102 kg (225 lbs)

Table 5-2: Model 10636

Dimensions		
Cabinet size	Height	1753 mm (69 inches)
	Depth	1016 mm (40 inches)
	Width	610 mm (24 inches)
Shipping size (with packing materials)	Height	1905 mm (75 inches)
	Depth	1219 mm (48 inches)
	Width	813 mm (32 inches)
Weight		
Operating		100 kg (220 lbs)
Shipping		123 kg (272 lbs)

Table 5-3: Model 10642

Dimensions		
Cabinet size	Height	2006 mm (79 inches)
	Depth	1016 mm (40 inches)
	Width	610 mm (24 inches)
Shipping size (with packing materials)	Height	2184 mm (86 inches)
	Depth	1219 mm (48 inches)
	Width	813 mm (32 inches)
Weight		
Operating		115 kg (253 lbs)
Shipping		148 kg (325 lbs)

Table 5-4: Model 10647

Dimensions		
Cabinet size	Height	2286 mm (90 inches)
	Depth	1016 mm (40 inches)
	Width	610 mm (24 inches)
Shipping size (with packing materials)	Height	2438 mm (96 inches)
	Depth	1219 mm (48 inches)
	Width	813 mm (32 inches)
Weight		
Operating		111 kg (245 lbs)
Shipping		129 kg (284 lbs)

Electrostatic Discharge

To prevent damaging the system, be aware of the precautions you need to follow when setting up the system or handling parts. A discharge of static electricity from a finger or other conductor may damage system boards or other static-sensitive devices. This type of damage may reduce the life expectancy of the device.

To prevent electrostatic damage, observe the following precautions:

- Avoid hand contact by transporting and storing products in static-safe containers.
- Keep electrostatic-sensitive parts in their containers until they arrive at static-free workstations.
- Place parts on a grounded surface before removing them from their containers.
- Avoid touching pins, leads, or circuitry.
- Always be properly grounded when touching a static-sensitive component or assembly.

Grounding Methods

There are several methods for grounding. Use one or more of the following methods when handling or installing electrostatic-sensitive parts:

- Use a wrist strap connected by a ground cord to a grounded workstation or computer chassis. Wrist straps are flexible straps with a minimum of 1 megohm \pm 10 percent resistance in the ground cords. To provide proper ground, wear the strap snug against the skin.
- Use heel straps, toe straps, or boot straps at standing workstations. Wear the straps on both feet when standing on conductive floors or dissipating floor mats.
- Use conductive field service tools.
- Use a portable field service kit with a folding static-dissipating work mat.

If you do not have any of the suggested equipment for proper grounding, have HP authorized reseller install the part

NOTE: For more information on static electricity, or assistance with product installation, contact your HP authorized reseller.

Transportation Instructions

NOTE: The following section is only a sampling of the many delivery considerations available. For more information, visit the Best Practices web page at www.hp.com.

Transportation Methods

Depending on your circumstances and time schedule, there are three transportation methods for transporting your rack: air, land, and sea.

Air Transport

All racks can be air freighted upright (on a pallet or shock pallet) or horizontally (in a crate). However, since the 10842 rack has a packaged height of 217 centimeters (85.4 inches) and the maximum height for air cargo is 218.4 centimeters (86 inches), only the largest cargo planes can accommodate it upright. If your destination does not accommodate large cargo planes, the 10842 rack must be air freighted horizontally in a crate.

A passenger plane with cargo space has a height limitation of 160 centimeters (63 inches). Because a palletized 10622 rack is below this limit, it can readily be delivered by air. It must be shipped upright on a pallet, and double-stacking is not allowed.



CAUTION: If your rack is an integrated model, it **MUST** be transported upright. If this is not possible, remove all components from the rack and prepare them for delivery, or choose an alternative transportation method.

Because of the dimensions and the weight of the racks, check with carriers for their limitations before dispatching.

Land Transport

All racks can be shipped by common carriers. Carriers providing air ride capabilities are preferred. Ship racks upright on their pallets. Do not lay the racks horizontally or double-stack them. Because of the dimensions and the weight of the racks, please check with carriers for their restrictions before dispatching.

Sea Transport

All racks can be transported by sea, but it takes four to six weeks for the shipment to arrive. Ship racks upright on their pallets. Do not lay the racks horizontally or double-stack them.

Delivery Services

HP provides two methods of delivery for customers in North America: Inside Rack Delivery Service and Expedited Rack Delivery Service. If you want both Inside Rack Delivery and Expedited Rack Delivery, you must specify **both** part numbers on your purchase order.

Inside Rack Delivery Service

Inside Rack Delivery Service (Part No. 184649-001) is available for receiving sites that do not have the proper facilities for the standard dock-to-dock delivery, or when you need delivery to a specific location within a site. The rack is transported as close as possible to the desired location. If a stairway or a non-accessible doorway is encountered, the rack is left there.

Highlights

- The palletized rack is unloaded by transportation personnel.
- Transportation personnel provide material-handling equipment.

- The rack is delivered to the desired location within the facility (see “Limitations”).
- Delivery service is for a single rack.

Limitations

- If shipping a non-integrated rack, door widths and corridors must accept a 99-centimeters x 122-centimeters (39-inches x 48-inches) pallet.
- Door heights and corridors must be at least 2 meters (79 inches) tall to accommodate the 10842 rack.
- A proper freight elevator must be available for deliveries to upper and lower floors.
- Transportation personnel will not remove the rack from the shipping pallet.
- Transportation personnel will not remove the pallet or packaging.

Expedited Rack Delivery Service

Expedited Rack Delivery Service (Part No. 184449-001) is available in the rare instances when air shipment of the rack is required.

Highlights

- Special packaging, such as crating, is provided as required.
- Shipment is made by an air carrier selected by HP.
- Delivery service is for a single rack.

Limitations

- This service is available only in the continental United States, Alaska, and Hawaii.
- Inside rack delivery is not included.

Shipping/Delivery Considerations

The following precautions should be observed when receiving the racks and components.

- A dock door is needed at the receiving site to accommodate the height and width of the palletized racks.
- When shipping a rack, the 99-centimeters x 122-centimeters (39-inch x 48-inch) pallet does not fit through a standard-width internal door, which is about 76.2 centimeters (30 inches) wide.
- The palletized 42U rack is approximately 216 centimeters (85 inches) high and does not fit through a standard-height door.
- Do not lay the rack horizontally because the sheet metal can become distorted.
- Transport the rack as far into the building as possible while still on the pallet. Then remove the rack from the pallet and roll the rack on its casters, being careful to keep the rack from tipping. Ideally, the palletized rack should be moved to its final destination and then removed from the pallet.

Symbols and Numbers

100 kilo sliding shelf rack option kit 1-4
1U keyboard drawer rack option kit 1-4
25-inch rail adapter rack option kit 1-4

A

AC supply branch circuit, warning 2-5
adjustable fixed rails
 installing on components 4-15
 preparing 4-7
air transport of rack B-1
airflow
 blanking panels 2-8
 fan kits 2-8
 requirements 2-8
 ventilation 2-8
attaching
 cable management arm 4-20
 cables 4-22
 power cords 4-22
authorized, service provider 1-4

B

balance, rack 2-3
ballast rack option kit 1-3
baying offset rack option kit 1-3
baying rack option kit 1-3
Best Practices web page 1-5

blanking panels, using 2-8
boot straps, using A-2

C

cable access panel
 illustrated 4-25
 removing 4-24
cable management arm
 bracket, installation 4-17
 installation 4-20
cable management D-ring rack option
 kit 1-4
cables
 attaching 4-22
 length 2-4
 routing 4-23
cage nuts, installation 4-6
cautions
 casters 3-8
 intergrated models B-1
 proper airflow and temperature 2-7
 verify AC voltage selector switches 2-6,
 4-25
clearance
 around power supply 2-5
 between wall and rack 4-3
 rack back 2-5
 rack front 2-5
 to unpack 2-5

component placement considerations
 balance 2-3
 baying option kits, number of 2-4
 configuring 2-3
 CRT monitor 2-3
 flat panel monitor 2-3
 height 2-3
 keyboard 2-3
 monitor 2-3
 PDU 2-3
 power 2-3
 side panels 2-4
 stabilizing feet 2-4
 switch box 2-3
 weight 2-3

components
 installation 4-18
 weight distribution/in rack 4-3

configuration
 factors 2-1
 Rack Builder Online 4-3
 server/storage vs. switching 3-10
 software for racks 2-1

considerations
 baying racks 2-4
 delivery 1-5
 height 2-3
 keyboard 2-3
 monitor 2-3
 side panels 2-4
 stabilizing feet 2-4

D

definition, U measurement 1-1

delivery
 considerations 1-5, B-4
 service, expedited B-3
 service, inside B-2
 services, overview B-2

depth adjustable fixed rail kit 1-4

E

electrostatic discharge *See* ESD

environment requirements
 airflow 2-8
 grounding 2-6
 space 2-5
 temperature 2-7

ESD (electrostatic discharge)
 obtaining additional information A-2
 precautions A-1
 preventing A-1
 storing products A-1
 transporting products A-1
 types of damage from A-1

expedited delivery service B-3

F

fan rack option kit 1-3

features
 cable access panel 1-2
 color 1-2
 HP 10000 Series racks 1-2
 interchangeable doors 1-2
 perforated front door 1-2
 perforated rack top 1-2
 perforated split rear doors 1-2
 Rack Builder Online 2-2

fixed rails
 installation 4-8
 preparing 4-7

flat panel monitor rackmount option kit 1-4

flat panel monitor, component
 placement 2-3

front door, opening 3-3

G

graphics, Rack Builder Online 2-2

graphite metallic, color 1-2

ground bonding rack option kit 1-3

grounding
 methods A-2
 requirements 2-6
 suggested equipment for A-2
grounding straps
 specifications A-2
 wearing A-2
guidelines for component installation 4-3

H

hardware shipped with rack 3-2
heel straps, using A-2
height, rack configuration
 considerations 2-3
HP 10000 Series racks
 features 1-2
 illustration 1-2
 option kits 1-3
 overview 1-1
HP authorized service provider 1-4
HP Rack Kit Components List 3-2

I

important
 cautions and warnings 4-18
 retaining fasteners 3-2
 standard installations 4-7
inserting components into rack 4-18
inside delivery service B-2
installation
 cable management arm 4-20
 cable management arm bracket 4-17
 cage nuts 4-6
 components 4-18
 overview 4-4
 fixed rails 4-8
 guidelines 4-2
 service 1-6
 sliding rails 4-14
 tools needed for 3-2
 zero U devices 4-4

interchangeable front and split rear
 doors 1-2

J

joining racks 2-4

K

keyboard
 rack configuration consideration 2-3
 required parts 2-3
kit components list 3-2

L

labeling, Rack Builder Online 2-2
land transport of rack B-2
leveling feet 3-8

M

Maximum Recommended Ambient
 Operating Temperature 2-7
measurements 2-3
model specifications 5-1
modes of operation, Rack Builder
 Online 2-2
monitor
 placement 2-3
 required parts 2-3
monitor/utility shelf rack option kit 1-3
multiple-racks
 configuration 2-2
 stabilizing 3-10
 tips 3-10

N

National Electric Code 2-6
National Electrical Regulations 2-4
networking cable and recessed rail
 management kits 1-3

note

- adjustable fixed rails 4-8, 4-9
- aligning rails 4-11
- ball bearings 4-19
- Best Practices web page B-1
- cable access panel 4-24
- cable management arm 4-21
- cable management arm bracket 4-17
- component rails 4-10
- rack mounting brackets 4-12
- routing cables 4-23
- sliding rail tabs 4-14
- stabilizer feet 4-4
- stabilizer option kit 3-9
- standard installations 4-4

O

opening

- front door 3-3
- rear doors 3-5

option kits 4-26

P

parts

- proper handling A-1
- storing A-1
- transporting A-1

PDU

- installation, location 1-5
- rack configuration consideration 2-3

perforated

- front and split rear doors 1-2
- rack top 1-2

power

- rack configuration consideration 2-3
- requirements 2-5

power cords, attaching 4-22

power distribution unit *See* PDU

preparing

- components 4-15
- rack door 3-3
- rack for component installation 3-1
- sliding rails 4-10

preparing and installing the rails 4-7

R

rack

- accessibility 3-3
- baying 2-4
- configuration software 1-5
- environment 2-5
- hardware list 3-2
- joining 2-4
- multiple, stabilizing 3-8
- option kits 1-3
- outside dimensions 2-5
- setup, completing 2-5
- shipping by air B-1
- shipping by land B-2
- shipping by sea B-2
- specifications 4-26
- standalone, stabilizing 3-8
- unpacking, space required 2-5

Rack Builder Online 1-5

- features 2-2
- Help Me Build It Mode 2-2
- Let Me Build It Mode 2-2
- modes of operation 2-2

rack configuration software 2-1

- drag and drop 2-2
- features 2-2
- graphics 2-2
- labeling 2-2
- multiple-rack configuration 2-2
- reports 2-2
- third-party reports 2-2

rack configuration utility 1-5

- rack doors, removing 3-3
 - rack kit components list 3-2
 - rack option
 - 100 kilo sliding shelf kit 1-4
 - 1U keyboard drawer kit 1-4
 - 25-inch rail adapter 1-4
 - ballast kit 1-3
 - baying kit 1-3, 3-10
 - baying offset kit 1-3, 3-10
 - blanking panels kit 4-26
 - cable management D-ring kit 1-4
 - depth adjustable fixed rail kit 1-4
 - fan kit 1-3
 - features 1-3
 - flat panel monitor rackmount kit 1-4
 - ground bonding kit 1-3
 - monitor/utility shelf kit 1-3
 - networking cable and recessed rail management kit 1-3
 - server console switch 1-3
 - shock pallet spares kit 1-4
 - side panels kit 1-3
 - stabilizer kit 1-3
 - TFT5600 rackmount keyboard and monitor kit 1-4
 - rack stability, warning 4-2
 - rack-mounting brackets, installation 4-14
 - rails, fixed
 - installing 4-8
 - preparing 4-7
 - rails, sliding
 - installing 4-14
 - preparing 4-10
 - rear doors, opening 3-5
 - removing
 - cable access panel 4-24
 - front door 3-3
 - rear doors 3-5
 - side panels 3-7
 - replacing side panels 3-7
 - reports, Rack Builder Online 2-2
 - requirements
 - airflow 2-8
 - blanking panels 2-8
 - grounding 2-6
 - power 2-5
 - space 2-5
 - temperature 2-7
 - tools 3-2
 - routing cables 4-23
- ## S
- safety information, grounding requirements 2-6
 - sea transport of rack B-2
 - server console switch 1-3
 - placement 2-3
 - required parts 2-4
 - server/storage configurations 3-10
 - service, installation 1-6
 - setup, rack, completing 3-1
 - shipping
 - by air B-1
 - by land B-2
 - by sea B-2
 - receiving B-4
 - shock pallet spares kit 1-4
 - side panels
 - considerations 2-4
 - removing 3-7
 - replacing 3-7
 - side panels rack option kit 1-3
 - sliding rails
 - installing 4-10, 4-14
 - installing on components 4-16
 - space required, between wall and rack 4-3
 - space requirements 2-5
 - specifications 5-1
 - stabilizer rack option kit 1-3, 3-8
 - stabilizing feet
 - considerations 2-4
 - using 3-9

- stabilizing multiple racks 3-10
- standalone racks, stabilizing 3-8
- static-safe containers
 - storing products in A-1
 - transporting products in A-1
- switch box *See* server console switch
- switching configurations 3-10
- system, preventing electrostatic damage to A-1

T

- temperature
 - preventing overheating 2-7
 - requirements 2-7
 - violation problems 2-7
- template, using 4-5
- TFT5600 rackmount keyboard and monitor
 - rack option kit 1-4
- third-party options 4-2
- third-party support, Rack Builder Online 2-2
- tips, multiple-rack configurations 3-10
- tools needed 3-2
- tools, conductive field service type A-2
- transporting rack
 - by air B-1
 - by land B-2
 - by sea B-2

U

- Uninterruptible Power System *See* UPS
- UPS
 - definition 2-3
 - installation, location 1-5

V

- ventilation for proper airflow 2-8
- voltage selection switch, caution 2-6

W

- warnings
 - AC supply branch circuit 2-5
 - component weight 4-18
 - loading the rack 4-2
 - power cord grounding 2-6, 4-25
 - rack stability 4-2
 - stabilizing feet 3-9
 - stabilizing the rack 4-2
 - stacking computer components 3-8
- weight 2-3
 - balancing between racks 2-3
 - component placement 2-3
 - connecting racks 2-3
- wiring requirements 2-4
- wrist straps
 - specifications A-2
 - using A-2

Free Manuals Download Website

<http://myh66.com>

<http://usermanuals.us>

<http://www.somanuals.com>

<http://www.4manuals.cc>

<http://www.manual-lib.com>

<http://www.404manual.com>

<http://www.luxmanual.com>

<http://aubethermostatmanual.com>

Golf course search by state

<http://golfingnear.com>

Email search by domain

<http://emailbydomain.com>

Auto manuals search

<http://auto.somanuals.com>

TV manuals search

<http://tv.somanuals.com>