

HP Designjet T1120 SD-MFP Assembly Instructions **EN**



CM719-90011

© 2009 Hewlett-Packard Company
Inkjet Commercial Division
Avenida Graells 501 · 08174
Sant Cugat del Vallès
Barcelona · Spain

All rights reserved

Printed in Germany Imprimé en Allemagne Stampato in Germania

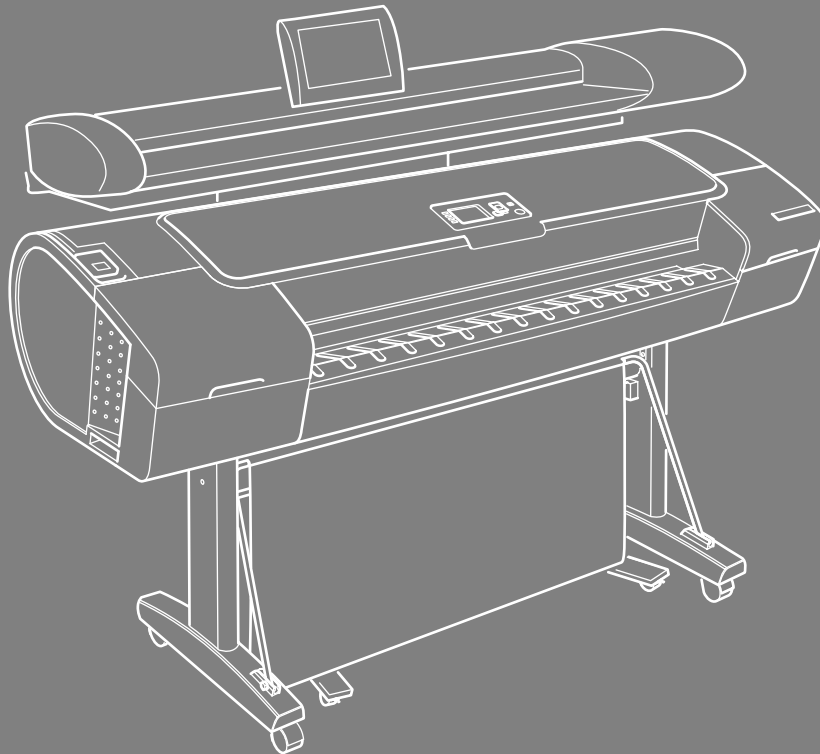

Read these instructions carefully...

What you will need for this procedure:

Because the scanner is heavy, you will need two people to unpack and set it up. When two people are needed, the symbol at the foot of this box is displayed.

You are required to clean the scan area glass plate during the assembly procedure: To do so you will need clean lint free cloths and a mild, streak-free glass cleaner. These are not provided with the scanner.



Your printer should already be assembled and working before starting this procedure. For instructions on how to assemble the printer, please refer to the assembly poster included with the printer.



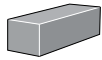

Box contents:

1. Maintenance sheet
2. Scanner
3. Top Tray
4. Leg Structure
5. Foot
6. Foot
7. Assembly Kit
8. Cables – USB, LAN, Power extension, Power
9. Assembly instructions

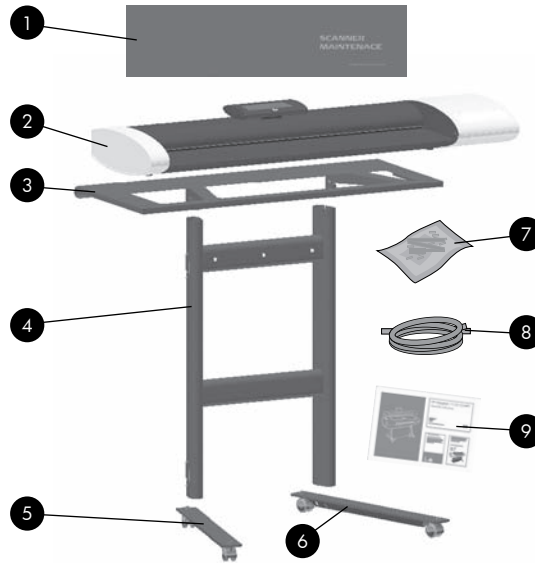

Assembly kit contents:

Description		Quantity
18 Torx M5x14 screws		18
4 Torx M5x25 scanner fixing screws		4
Torx screwdriver		1
Stylus (Pointing device)		1
Stoppers		2
Maintenance sheet hang-hooks		2
Allen key		1

1 Open the box: to do so, you need to raise the flap on the end, and then lift the lid off.

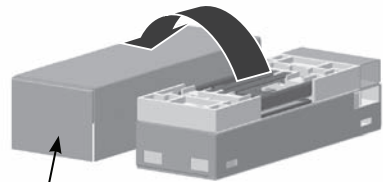

Raise the flap, and lift the lid off

2 Take the 2 feet out of the box. Take the leg structure from the box and place it, with the clips facing forward up, on the floor.



3 Take one of the feet from the box. Align the foot with the leg on the leg structure, making sure it is in its correct position and angle. Insert the leg structure's guiding-peg into the middle hole on the foot.

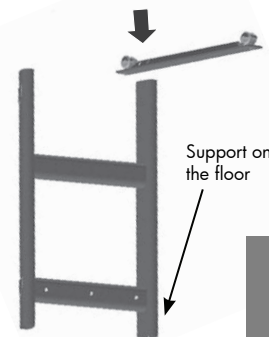

4 Fasten the foot using 4 M5x14 screws. Insert all 4 screws loosely and then tighten using the Torx screwdriver.

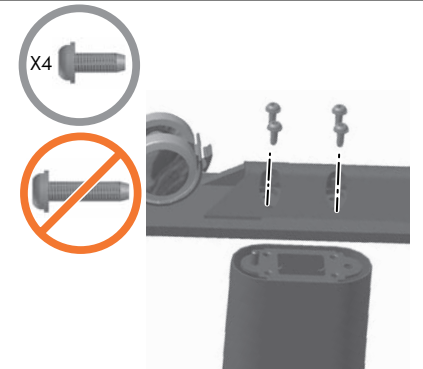

5 Take the other foot from the box. Align the foot with the other leg on the leg structure, making sure it is in its correct position and angle. Insert the leg structure's guiding-peg into the middle hole.



6 Fasten the foot using 4 M5x14 screws. Insert all 4 screws loosely and then tighten using the Torx screwdriver.

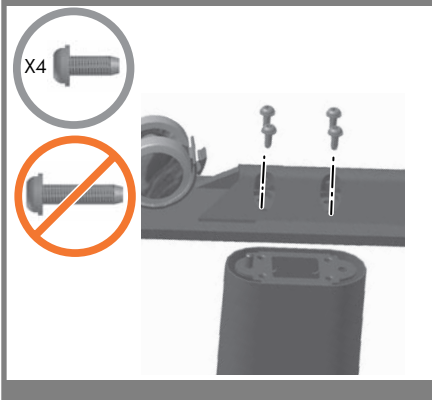

7 Place the leg structure upright. Be sure that all four wheels are locked.

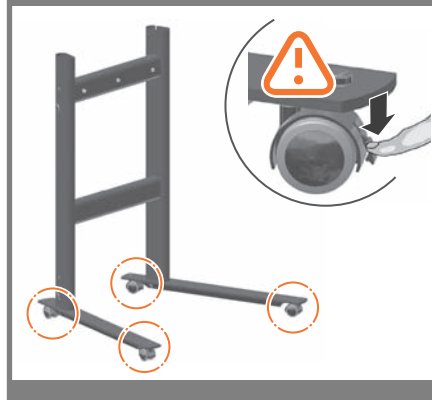

8 Using 2 people; take the Top Tray from the box. Position the Top Tray on the leg structure with the rounded edge facing the back and its flat edge facing the front. Insert the tray's bottom mounts into the 2 leg tops.

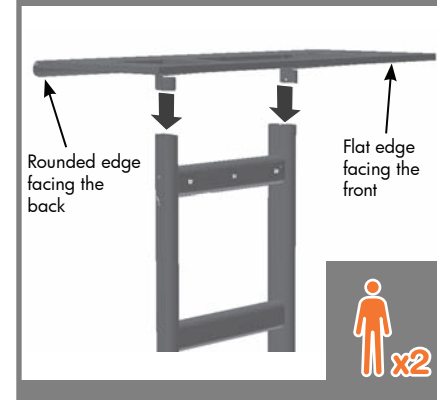

9 Fasten the Top Tray using 4 M5x14 screws: insert 2 screws loosely on each leg, when all 4 screws are in place, tighten with the Torx screwdriver.

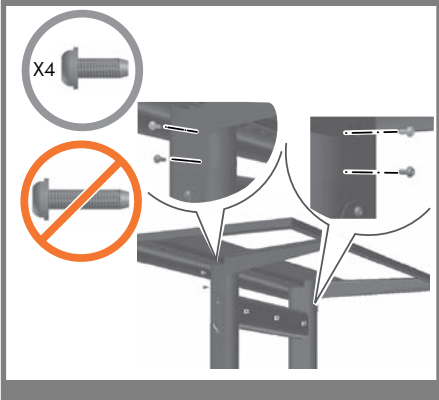

10 Make sure you have fully removed the top of the box. Remove the Maintenance sheet (required later), and packing pieces.

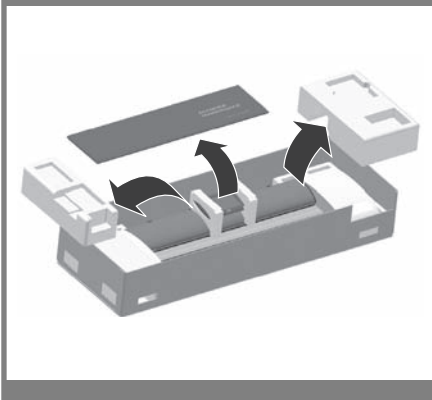

11 Using 2 people; lift the scanner from the box and place it on the Top Tray. Align the scanner's 4 rubber feet so they rest in the Top Tray's sink holes (a). Remove the 2 protective foam pieces from the touch-screen (b).

Attach scanner to stand

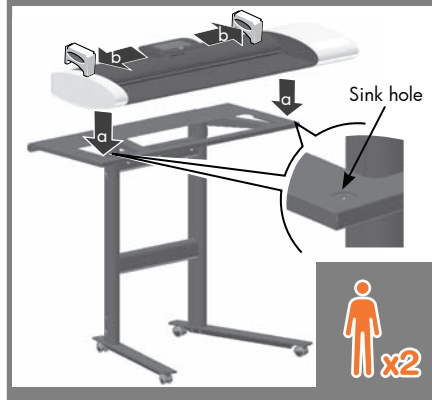

12 Fix the scanner to the Top Tray with the 4 Torx M5x25 scanner fixing screws. Insert the screws through the holes in the bottom of the tray and screw them into the scanner's rubber feet using the Allen key.

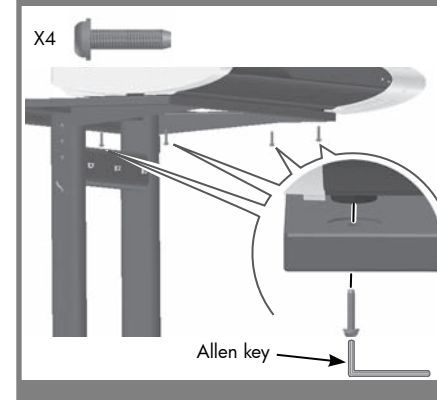

- 13** For its protection, the scanner's touch-screen is shipped folded down in its "transportation" position, and needs to be lifted up and locked in its "ready" position. Grasp the top edge of the screen with one hand.



- 14** Pull the touch-screen back towards you until you hear the click that indicates it is locked in its upright "ready" position.

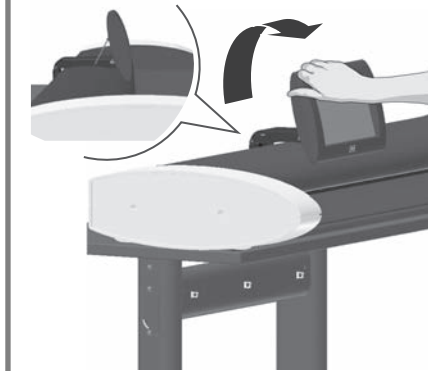

- 15** Attach the stylus to the touch-screen.

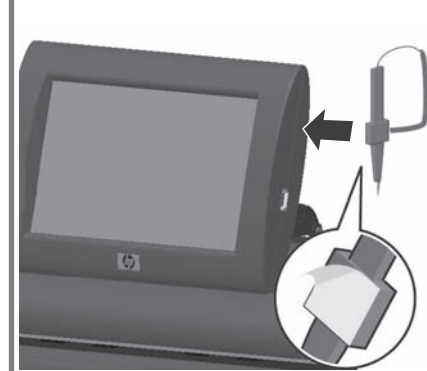

- 16**
- Cleaning the scan area...**
You are now required to clean the scan area - glass plate. To do so you will need clean lint free cloths and a mild, streak-free glass cleaner. These are not provided with the scanner.



Caution: do not use abrasives, acetone, benzene, or fluids that contain these chemicals. Do not spray liquids directly onto the scanner glass plate or anywhere else in the scanner.

- 17** To access the scan area, you need to open the scanner lid. Push the touch screen so it twists backwards on its arm until it rests in its "service" position.



- 18** There are 2 lid release buttons at the back of the scanner. Simultaneously press the buttons inwards with your fingers until you feel them unlock.

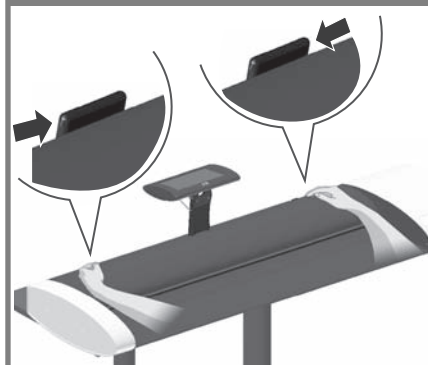

- 19** Retain pressure on the lid release buttons and your grip on the lid edge, and pull the lid backwards towards your body. Open the scanner lid all the way back.



- 20** Apply a mild, streak-free glass cleaner to a lint-free cloth, such as the one supplied with your scanner, and gently clean the glass surface. The surface must be very clean; any dirt will appear on a print.



21 Dry the glass fully using a separate clean, dry lint-free cloth.

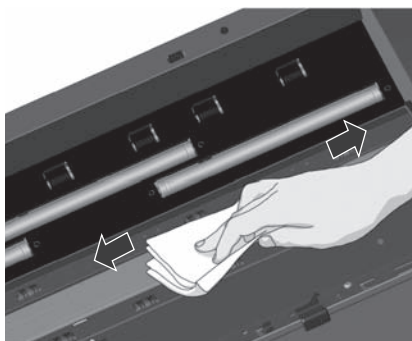

22 Close the scanner lid and gently push it down to lock it into place.



23 Pull the touch-screen back down to the "ready" position.

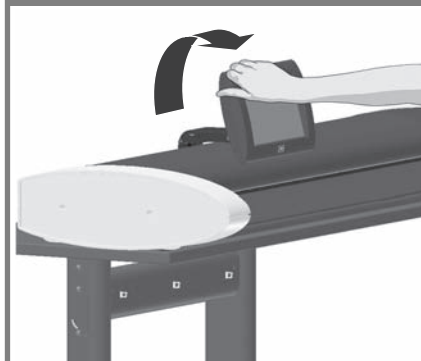

24 Attach the USB cable to the scanner.

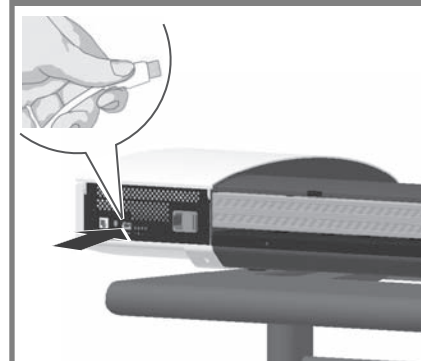

Cabling and connecting

25 Insert the clips under the Top Tray to mount the USB cable where shown below. Mount the cable and let the end hang from the last clip. The cable will be connected to the printer in a later step.

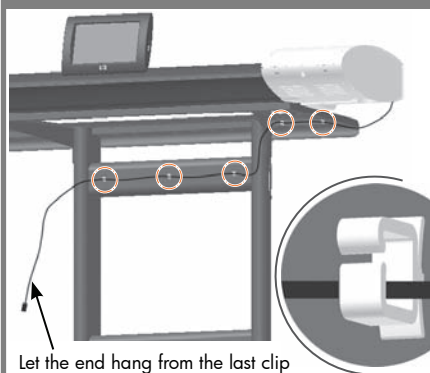

26 Screw the stoppers into the holes on the stand leg structure.

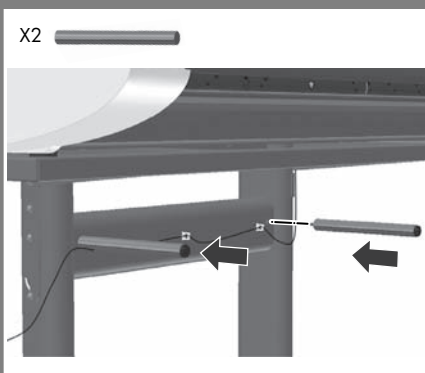

27 Attach the maintenance sheet hang hooks on the stoppers. Note: This is where the maintenance sheet is stored when not in use. It is connected to the hang hooks with velcro.

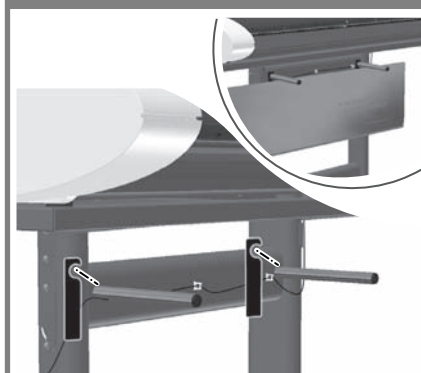

28 Slide the assembled printer under the scanner. The printer's feet will be positioned outside the scanner's feet.

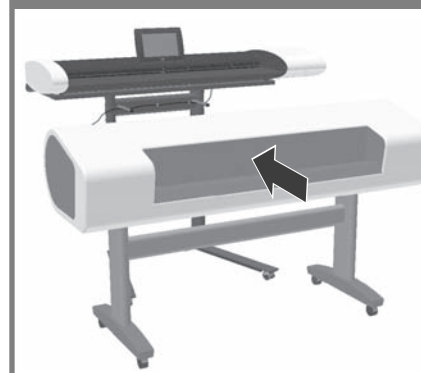

29 Your HP Designjet T1120 scanner is now assembled, and should appear as in the below illustration.



30 Connect the printer to the scanner with the USB cable. Adjust the cable to leave enough slack to be able to pull out the printer when changing paper.

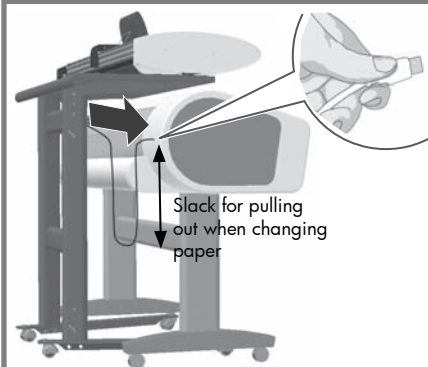

31 Connect the printer's LAN cable to the printer. Note: only 1 LAN cable is supplied with the scanner; you will need a separate one for the printer.

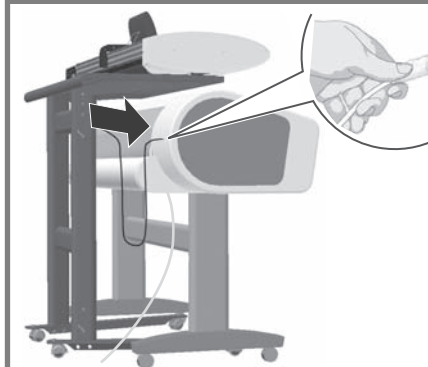

32 Feed the LAN cable through the leg: loosen the bottom screw on each hole's cover, rotate the cover open to expose the hole (a). Insert the free end of the LAN cable in the top hole (b) and pull it out of the bottom hole (c). Leave enough slack in the cable to be able to pull out the printer when changing paper.

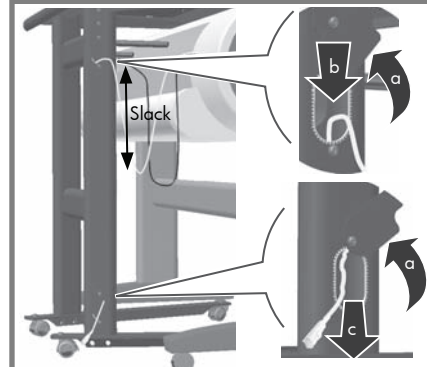

33 Plug the LAN cable into a connection socket.

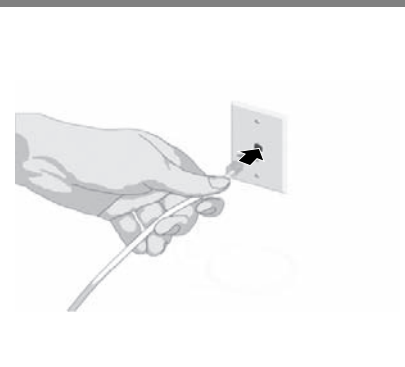

34 Connect the printer's power cable to the printer.

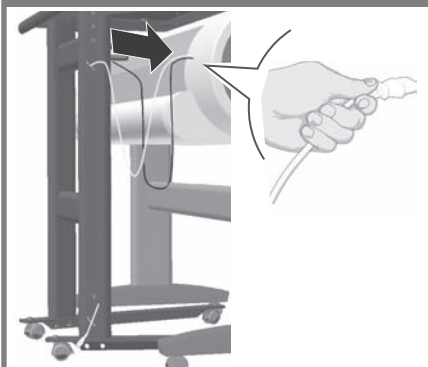

35 Feed the power cable through the leg: Insert the end of the cable into the top hole (a) and pull it out of the bottom hole (b). Leave enough slack in the cable to be able to pull out the printer when changing paper. Push the hole covers back down and tighten the screws (c).

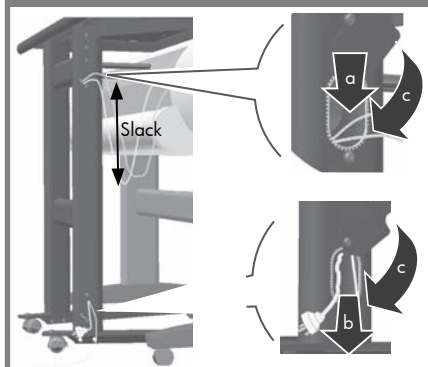

36 Connect the printer's power cable to a power outlet (a) and switch the printer on (b).

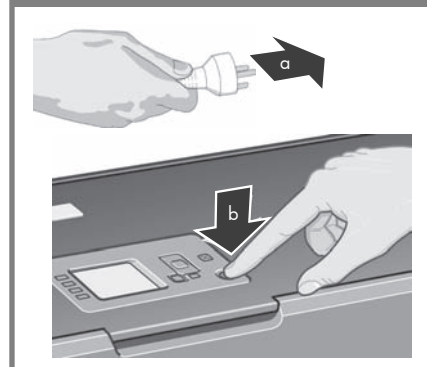

37 Connect the scanner's LAN cable to the scanner.

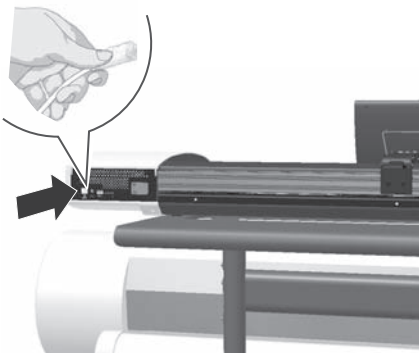

38 Feed the LAN cable through the leg: loosen the bottom screw on each hole's cover, and rotate the cover open to expose the hole (a). Insert the free end of the LAN cable in the top hole (b) and pull it out of the bottom hole (c).

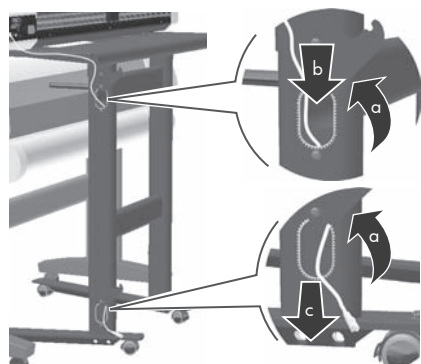

39 Plug the LAN cable into a connection socket.

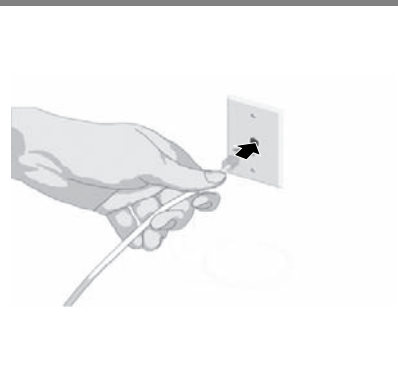

40 Connect the power extension cable's plug end to the scanner.

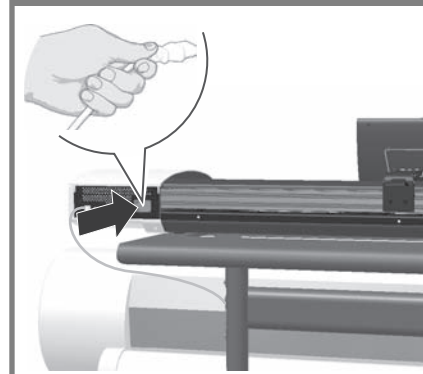

41 Feed the power extension cable through the leg: Insert the end of the cable in the top hole (a) and pull it out of the bottom hole (b). Push the hole covers back down and tighten the screws (c).

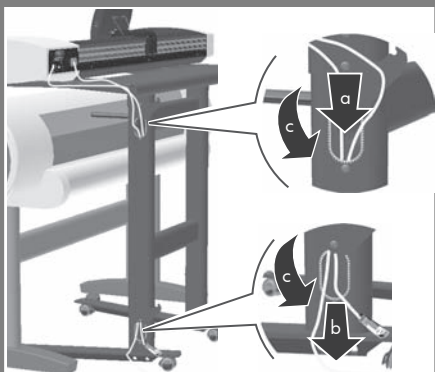

42 Connect the scanner power cable to the scanner power extension cable.

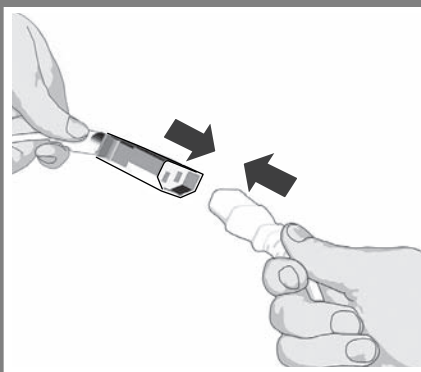

43 Connect the scanner power cable to a power outlet (a) and switch the scanner on (b).

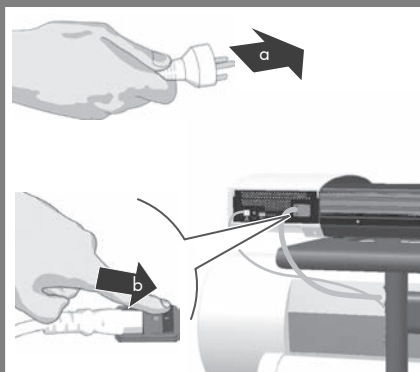

44 Your scanner screen will flash on and take you through your system's installation steps. You start by calibrating the screen. You touch the arrows at each corner as they appear. Touch the middle dialog to control and end the screen calibration.

System installation



45 Select the language for the software interface.



46 Accept the licence agreement.



47 Set your local date and time. The time zone for your area and daylight period is set in relation to GMT.



48 Enter your network settings to join your system with your local network. Select the DHCP option for automatic setup (on DHCP server networks) or enter the correct IP data manually.



49 Define one or more initial destinations for scanned files (accessible folders on the network): Press the Add button to define a destination. Enter a label, the full network path to the folder and login information. Check 'Remember' if the password should be stored after power down.



50 Press the Test Connection button to verify your entries. Press OK when done. Repeat the steps 49 and 50 if you want to enter additional destinations. NOTE: If you will only scan to USB, press the cancel button to skip this step. You can create additional destinations later on.



51 Your system now has all the information it needs and will start up in the Copy screen.



52 For any further information on how to use your scanner, see the online help available from your touch screen.

Notes and advice



53 You will find these instructions useful again if you setup and install the system at another location.

Keep these instructions



Free Manuals Download Website

<http://myh66.com>

<http://usermanuals.us>

<http://www.somanuals.com>

<http://www.4manuals.cc>

<http://www.manual-lib.com>

<http://www.404manual.com>

<http://www.luxmanual.com>

<http://aubethermostatmanual.com>

Golf course search by state

<http://golfingnear.com>

Email search by domain

<http://emailbydomain.com>

Auto manuals search

<http://auto.somanuals.com>

TV manuals search

<http://tv.somanuals.com>