

HEATRAE SADIA

The quality name in water heating

Unvented water heating

Multipoint 75/100





Unvented water heating

The demand for unvented systems continues to increase as their benefits are recognised by specifiers, installers and end users. The new Multipoint 75 and 100 litre units offer unvented water heater performance and are quicker and easier to install.

Based on the highly successful Multipoint range, the new 75 and 100 litre models are designed to significantly reduce installation time. These wall mounted units are supplied factory-assembled with all necessary valves and controls pre-installed ready for connection to the mains services resulting in a much easier, faster and neater installation.

Mains pressure and high flow rates at all hot taps

Balanced hot/cold water supplies

Ideal for multi-basin installations

Flexible siting - no need for cold water cistern

Can be used with standard taps



Multipoint 75/100

Multipoint 75/100 are ideal for commercial applications such as cloakrooms, kitchens or washrooms, where a single heater is required to service multiple draw-offs. Both products may also be used for single point showering and are available with 6kW rating (2 x 3kW elements) for use in locations where faster hot water recovery is required.*

As with all unvented units above 15 litres, it is a Building Regulation requirement that installers are competent to install Multipoint 75 and 100 litre units. This normally means having successfully completed a course in unvented systems. For details on training courses call 0845 600 7402.

75 and 100 litre capacities

Choice of 3.0kW or 6.0kW rating

Factory-fitted temperature and pressure relief valves

Twin heavy gauge copper inner containers

Replaceable long life alloy sheathed elements

Adjustable thermostats 5°C to 75°C max.

Suitable replacement for Cistern-type water heaters where improved water flow required

CFC/HCFC free (ODP zero) insulation GWP 3.1 (Global Warming Potential)

Element 'On' indicator

No anodes to inspect or replace

Suitable for use with any standard mixers or taps

Fitted with 1 metre of 3-core cable

Comprehensive installation instructions

BEAB and kiwa approved

Five year on-site parts and labour inner container guarantee

Items supplied factory fitted to all units

Expansion vessel

Pressure relief (expansion) valve

Temperature & pressure relief valves

Items supplied loose

Combined pressure-reducing valve with built-in strainer

Tundish

Mounting brackets

Multipoint 75/100 selection matrix

Capacity	Basins
75	5 to 8
100	8 to 10

N.B. Figures are for guidance only, the Heatrae Sadia Specifier Advice team should be contacted to discuss requirements for specific sites.

* Depending on demand, increased effective capacity and levels of user protection can be achieved by the use of Heatrae Sadia's thermostatic blending valve Pack U3 or U7 (See page 6).

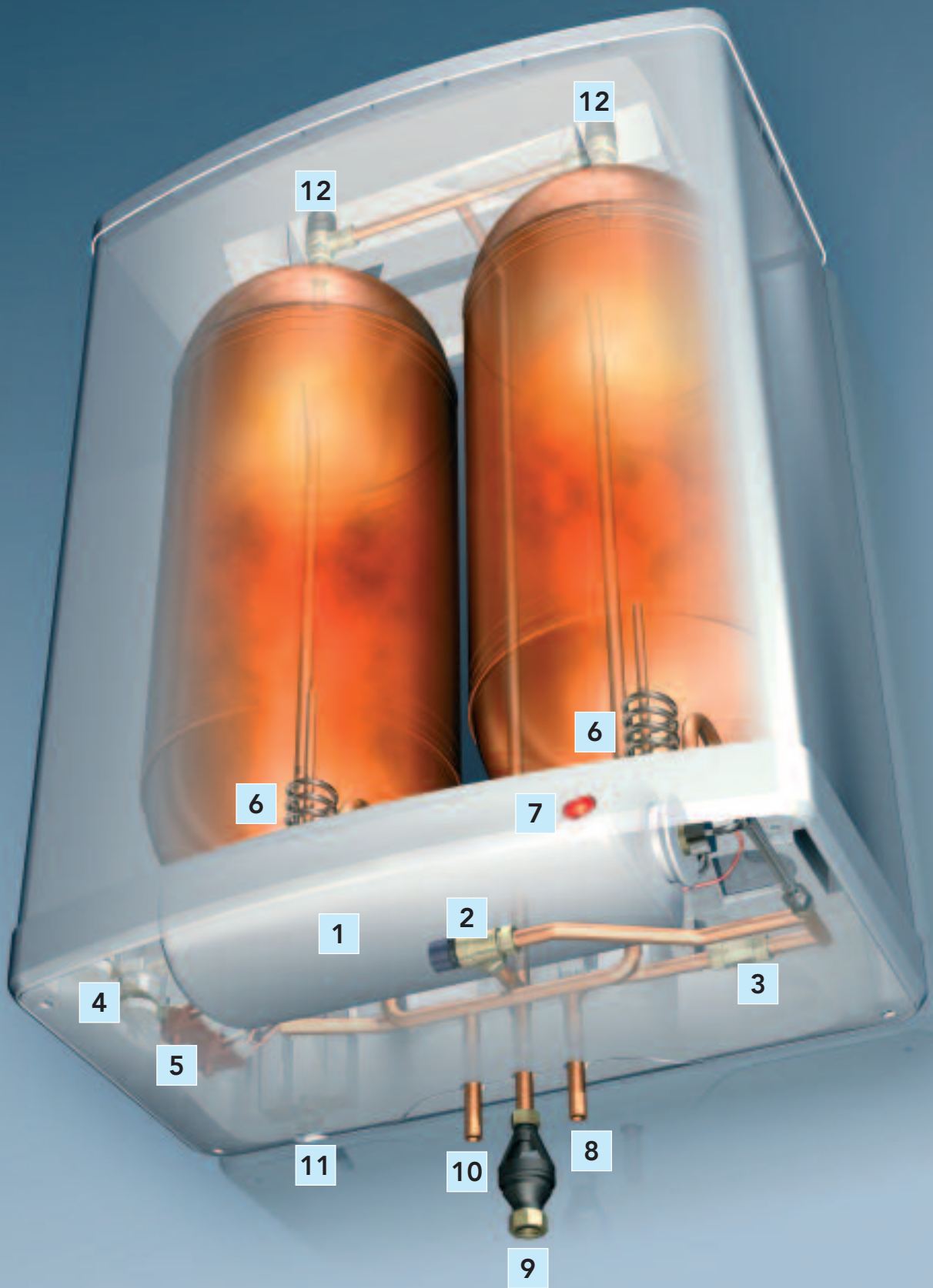

- | | |
|----------------------------|---|
| 1 Expansion vessel | 7 Element 'On' neon |
| 2 Pressure relief valve | 8 Inlet |
| 3 Non return valve | 9 Discharge |
| 4 Thermostats | 10 Outlet |
| 5 Safety cut-outs | 11 Cable entry |
| 6 Element plate assemblies | 12 Temperature and pressure relief valves |

Multipoint 75/100 ACCESSORIES

Thermostatic blending valves

Pack U3 and U7 for use with all Multipoints;

Thermostatic blending valves allow water to be stored at high temperatures and blended with cold water to a preset outlet temperature. This provides over-temperature protection, and is ideal for the control of Legionellae and the extension of system capacities.



PACK U3 TMV2

Connection 15mm compression.

Allows water to be safely stored above 60°C

Precisely controls outlet water temperature (range 35°C to 60°C)

Lockable control knob

Fail-safe shutdown

Incorporates check valves to prevent cross contamination

Operating pressure 0.2 bar to 6.0 bar



PACK U7 TMV3

Connection 15mm compression.

Fully approved under the TMV3 scheme to the DO8 specification

Allows water to be safely stored above 60°C

Precisely controls outlet water temperature (range 38°C to 46°C)

Unique adjuster key to prevent unauthorised temperature adjustment

Fail-safe shutdown

Incorporates check valves to prevent cross contamination

Operating pressure 0.2 bar to 5.0 bar

TMV Installation

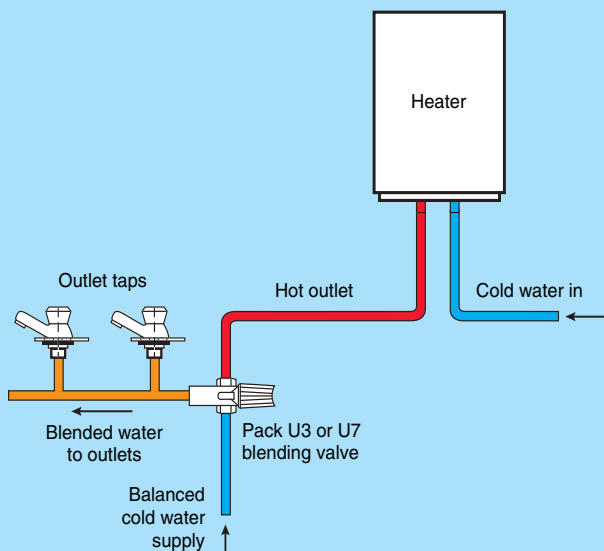

Technical Support

Heatrae Sadia offers a dedicated Specifier Advice line to provide information and advice on specification and installation. This is supported by a fully-trained national sales team, all of whom are qualified to provide further guidance and support locally.

Water expands by up to 4% when heated (See Fig. 1). This means that the design of the water heater and the installation in which it is used are critical. Conventional (vented) and unvented systems allow for expansion in different ways.

FIG. 1

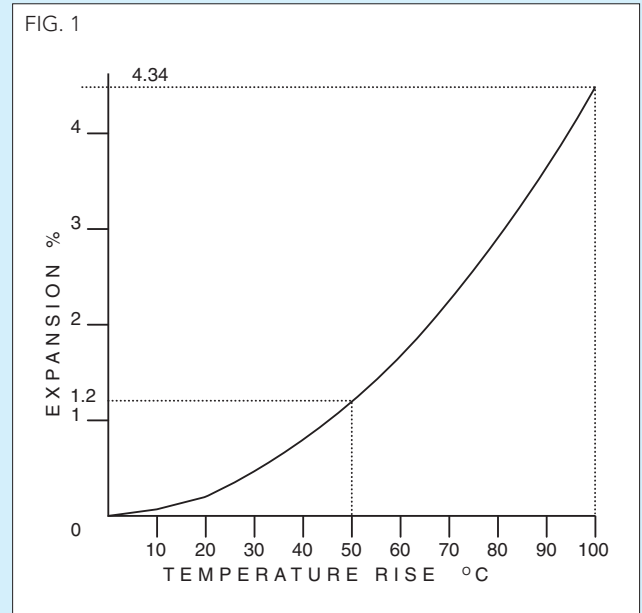

With unvented systems, there are no cistern tanks or open outlets to accommodate expansion. All systems above 15 litre, and some systems of 15 litre or less, employ an expansion vessel or an internal air-gap to accommodate expansion.

With larger systems (above 15 litre), expansion is accommodated either by a separate expansion vessel or an internal air-gap. Multipoint 75 and 100 litre units use an expansion vessel which is supplied factory fitted within the casing. They are supplied complete with all the necessary components and controls to provide a safe and efficient method of providing stored mains pressure hot water.

Building Regulations

Direct connection to the cold mains supply has been permitted in the UK since 1987. All units above 15 litre must be installed to meet the requirements of the Building Regulations. It is a legal requirement that the local Building Control Officer be notified of any proposed installation of unvented water heating systems over 15 litre capacity. Products up to 500 litre and 45kW must be approved by a recognised body such as the British Board of Agrément (BBA) and BEAB and be fitted by an installer who has successfully completed a recognised course in the installation of unvented heating systems such as CITB.

Requirements call for an expansion space (internal or external), safety devices to prevent the stored water exceeding 99°C, and pipework to convey discharged hot water safely away from the safety devices.

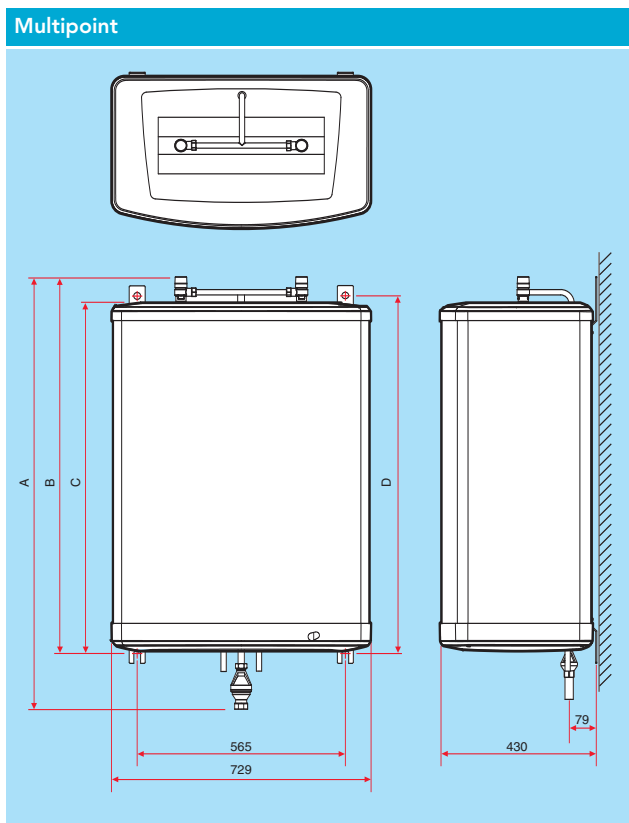

Dimensions and capacities

Model	Capacity litre	A mm	B mm	C mm	D mm
Multipoint 75	75	1055	911	824	843
Multipoint 100	100	1213	1069	982	1001

Specification

Capacities 75 and 100 litre.

Rating 3.0kW @ 240V (2 x 1.5 kW), (2.8kW @ 230V (2 x 1.4 kW)), 6.0kW @ 240V (2 x 3.0 kW), (5.6kW @ 230V (2 x 2.8 kW))

Outer casing White plastic top and base mouldings with steel centre section finished in white stove enamel.

Thermal insulation CFC/HCFC free (ODP zero) GWP 3.1 (Global Warming Potential) flame-retardant expanded polyurethane.

Water container 2 x Heavy gauge copper inner containers.
Type tested to 20 bar (290 psi)

Heat unit Replaceable Superloy 825 alloy sheathed rod-type elements.

Thermostat Capillary thermostats, adjustable from 5°C to 75°C.

Safety features Manually re-settable thermal cut-outs.

Factory-fitted temperature and pressure relief valves set to operate at 7 bar and 90°C.

Anode Not required.

Approvals BEAB and kiwa approved to UK water supply regulations. Manufactured in the UK in a BS EN ISO 9001:2000 registered factory.

Electrical The unit must be permanently connected to the electrical supply through a double-pole linked switch with minimum breaking capacity suitable for the loading. Must conform to current IEE wiring regulations.



Installation

Must be installed by a competent person in accordance with local Regulations.

England and Wales - Building Regulations G3, Scotland - Technical Standards P3, N. Ireland - Building Regulations P5.

Fixing Mounting brackets supplied loose. Must be mounted in the vertical position with inlet/outlet at the bottom. Temperature and pressure relief valves factory fitted to the top of the heater.

Plumbing Connections 15mm copper tube tails. Minimum water pressure 0.8 bar (12 psi). Discharge from tundish 22mm compression

Tundish Multipoint 75 & 100 units are supplied with a tundish. Inlet - 1/2" BSP male. Outlet - 3/4" BSP female.

Service valve 15mm compression.

Safety valve discharge Temperature and pressure relief valve and expansion valve must be plumbed to discharge in a safe visible manner. (Tundish supplied).

Guarantee

Multipoint is covered by the Heatrae Sadia on-site parts and labour guarantee.

Multipoint inner container is guaranteed for a period of five years and its immersion heater and thermal control for a period of two years from the date of purchase against faulty manufacture and materials provided that:

- Has been correctly installed as per the instructions contained in the instruction manual and all relevant codes of practice and regulations in force at the time of installation.
- Has not been modified in any way, other than by Heatrae Sadia Heating.
- Has been regularly maintained in accordance with the instructions contained in the instruction manual.
- Has not been damaged by frost or due to scale.
- Has only be used with potable water.
- Has not been tampered with or been subjected to misuse or neglect.
- Registration card has been completed by the user and returned to Heatrae Sadia within 60 days of installation together with the proof of purchase.
- Has been installed in the United Kingdom.
- The guarantee is transferable.
- The guarantee does not affect your statutory rights.

The unit is not guaranteed against damage by frost. The Multipoint immersion heater and thermal controls are guaranteed for a period of two years, from the date of purchase, with the exception of damage due to excessive scaling. Evidence of purchase and date of supply must be submitted. The guarantee will not be transferable. This guarantee does not affect your statutory rights.



Ordering guide

Model	Rating @ 240V kW	Product code
Multipoint 75	3	95:050:170
Multipoint 75	6	95:050:171
Multipoint 100	3	95:050:172
Multipoint 100	6	95:050:173
Pack U3 (TMV2)		95:970:354
Pack U7 (TMV3)		95:970:360

HEATRAE SADIA

The quality name in water heating

Products

Boiling water Supreme | Supreme SS

Chilled water SuperChill

Cistern-fed water heating MegaLife HE

Cistern-type water heating FBM

Electric flow boiler Amptec | Electromax

Electric showers Accolade | Carousel | Sapphire | Cameo

Hand hygiene Handy | Concept | Hair Drier | Handy Dri

Immersion heaters Titanium | Superloy | Gold Dot | Maxistore | RDT Thermostats

Point of use Streamline | Express | UTC 99 | B3M | C3M | Vented tap range

Small unvented water heating Hotflo | Multipoint

Unvented water heating Megaflo HE | Megaflo HE SystemFit | Multipoint 75/100

For free product brochure(s) call our literature hotline on 01603 420127

Contact

Specification T: 01603 420220 F: 01603 420229 E: specifier@heatraesadia.com

Sales T: 01603 420110 F: 01603 420149 E: sales@heatraesadia.com

Service T: 01603 420330 F: 01603 420349 E: service@heatraesadia.com

Web www.heatraesadia.com

National service network

Heatrae Sadia products are inherently reliable and are designed to meet the demanding needs of all users.

A nationwide network of experienced engineers is available to provide fast and efficient on-site service support.

In addition, spare parts for the complete range of products are readily available through a wide variety of stockists.



Heatrae Sadia Heating Hurricane Way Norwich Norfolk NR6 6EA

Heatrae Sadia Heating may introduce modifications to their products from time to time. Consequently, the details given in this brochure are subject to alteration without notice.

95 900 871 Issue 1 © Heatrae Sadia Heating. March 2006.

A division of **BAXI GROUP**

Free Manuals Download Website

<http://myh66.com>

<http://usermanuals.us>

<http://www.somanuals.com>

<http://www.4manuals.cc>

<http://www.manual-lib.com>

<http://www.404manual.com>

<http://www.luxmanual.com>

<http://aubethermostatmanual.com>

Golf course search by state

<http://golfingnear.com>

Email search by domain

<http://emailbydomain.com>

Auto manuals search

<http://auto.somanuals.com>

TV manuals search

<http://tv.somanuals.com>