

HP ProLiant DL365 Server Maintenance and Service Guide



Part Number 418289-005
March 2008 (Fifth Edition)

© Copyright 2006, 2008 Hewlett-Packard Development Company, L.P.

The information contained herein is subject to change without notice. The only warranties for HP products and services are set forth in the express warranty statements accompanying such products and services. Nothing herein should be construed as constituting an additional warranty. HP shall not be liable for technical or editorial errors or omissions contained herein.

Microsoft and Windows are U.S. registered trademarks of Microsoft Corporation.

AMD Opteron is a trademark of Advanced Micro Devices, Inc.

Audience assumptions

This guide is for an experienced service technician. HP assumes you are qualified in the servicing of computer equipment and trained in recognizing hazards in products with hazardous energy levels and are familiar with weight and stability precautions for rack installations.

Contents

Customer self repair	5
Parts only warranty service.....	5
Illustrated parts catalog	16
Mechanical components	16
System components	19
Removal and replacement procedures	23
Required tools.....	23
Safety considerations.....	23
Preventing electrostatic discharge	23
Symbols on equipment.....	23
Server warnings and cautions.....	24
Preparation procedures.....	25
Extend the server from the rack.....	25
Power down the server	25
Remove the server from the rack	26
Hard drive blanks	26
Hot-plug SAS or SATA hard drives.....	27
Front bezel.....	27
Hard drive bezel blanks.....	28
Hot-plug power supply.....	29
Power supply blank	30
Access panel	30
Air baffle.....	31
Fan module	31
Battery tray.....	32
Battery pack	33
Multibay blank or device	34
Multibay backplane assembly	35
SAS backplane	36
Systems Insight Display	37
PCI riser board assembly	38
PCI-X or PCI Express expansion board.....	39
PCI Express riser board.....	40
Integrated HP Smart Array E200i Controller or HP Smart Array P400i Controller.....	41
DIMMs.....	42
Heatsink.....	43
Processor.....	44
System battery	50
System board	51
Cabling	58
Cabling overview.....	58
Array controller cabling	58
HP Smart Array E200i Controller cabling	58
HP Smart Array P400i Controller cabling	59

PCI Smart Array controller cabling	59
Battery pack cabling.....	60
Diagnostic tools	62
Troubleshooting resources	62
Array Diagnostic Utility	62
HP Instant Support Enterprise Edition	62
HP Insight Diagnostics survey functionality	63
HP ROM-Based Setup Utility	63
Integrated Management Log.....	63
Automatic Server Recovery	64
HP Systems Insight Manager	64
HP Insight Diagnostics	64
Web-Based Enterprise Service	64
Open Services Event Manager	65
Component identification	66
Front panel components	66
Front panel LEDs and buttons.....	67
Rear panel components	68
Rear panel LEDs and buttons	69
System board components	70
System maintenance switch	71
NMI jumper.....	71
HP Systems Insight Display and LEDs	71
HP Systems Insight Display LEDs and internal health LED combinations	72
SAS and SATA device numbers	73
SAS and SATA hard drive LEDs	74
SAS and SATA hard drive LED combinations	75
Fan locations	76
Specifications	77
Environmental specifications.....	77
Server specifications.....	77
Hot-plug power supply calculations	78
DDR2 SDRAM DIMM specifications	78
1.44-MB diskette drive specifications	78
CD-ROM drive specifications.....	79
DVD-ROM drive specifications.....	80
SAS hard drive specifications.....	81
SATA hard drive specifications.....	81
Acronyms and abbreviations.....	82
Index.....	84

Customer self repair

HP products are designed with many Customer Self Repair (CSR) parts to minimize repair time and allow for greater flexibility in performing defective parts replacement. If during the diagnosis period HP (or HP service providers or service partners) identifies that the repair can be accomplished by the use of a CSR part, HP will ship that part directly to you for replacement. There are two categories of CSR parts:

- **Mandatory**—Parts for which customer self repair is mandatory. If you request HP to replace these parts, you will be charged for the travel and labor costs of this service.
- **Optional**—Parts for which customer self repair is optional. These parts are also designed for customer self repair. If, however, you require that HP replace them for you, there may or may not be additional charges, depending on the type of warranty service designated for your product.

NOTE: Some HP parts are not designed for customer self repair. In order to satisfy the customer warranty, HP requires that an authorized service provider replace the part. These parts are identified as "No" in the Illustrated Parts Catalog.

Based on availability and where geography permits, CSR parts will be shipped for next business day delivery. Same day or four-hour delivery may be offered at an additional charge where geography permits. If assistance is required, you can call the HP Technical Support Center and a technician will help you over the telephone. HP specifies in the materials shipped with a replacement CSR part whether a defective part must be returned to HP. In cases where it is required to return the defective part to HP, you must ship the defective part back to HP within a defined period of time, normally five (5) business days. The defective part must be returned with the associated documentation in the provided shipping material. Failure to return the defective part may result in HP billing you for the replacement. With a customer self repair, HP will pay all shipping and part return costs and determine the courier/carrier to be used.

For more information about HP's Customer Self Repair program, contact your local service provider. For the North American program, refer to the HP website (<http://www.hp.com/go/selfrepair>).

Parts only warranty service

Your HP Limited Warranty may include a parts only warranty service. Under the terms of parts only warranty service, HP will provide replacement parts free of charge.

For parts only warranty service, CSR part replacement is mandatory. If you request HP to replace these parts, you will be charged for the travel and labor costs of this service.

Réparation par le client (CSR)

Les produits HP comportent de nombreuses pièces CSR (Customer Self Repair = réparation par le client) afin de minimiser les délais de réparation et faciliter le remplacement des pièces défectueuses. Si pendant la période de diagnostic, HP (ou ses partenaires ou mainteneurs agréés) détermine que la réparation peut être effectuée à l'aide d'une pièce CSR, HP vous l'envoie directement. Il existe deux catégories de pièces CSR:

- **Obligatoire** - Pièces pour lesquelles la réparation par le client est obligatoire. Si vous demandez à HP de remplacer ces pièces, les coûts de déplacement et main d'œuvre du service vous seront facturés.
- **Facultatif** - Pièces pour lesquelles la réparation par le client est facultative. Ces pièces sont également conçues pour permettre au client d'effectuer lui-même la réparation. Toutefois, si vous demandez à HP de remplacer ces pièces, l'intervention peut ou non vous être facturée, selon le type de garantie applicable à votre produit.

REMARQUE: Certaines pièces HP ne sont pas conçues pour permettre au client d'effectuer lui-même la réparation. Pour que la garantie puisse s'appliquer, HP exige que le remplacement de la pièce soit effectué par un Mainteneur Agréé. Ces pièces sont identifiées par la mention "Non" dans le Catalogue illustré.

Les pièces CSR sont livrées le jour ouvré suivant, dans la limite des stocks disponibles et selon votre situation géographique. Si votre situation géographique le permet et que vous demandez une livraison le jour même ou dans les 4 heures, celle-ci vous sera facturée. Pour bénéficier d'une assistance téléphonique, appelez le Centre d'assistance technique HP. Dans les documents envoyés avec la pièce de rechange CSR, HP précise s'il est nécessaire de lui retourner la pièce défectueuse. Si c'est le cas, vous devez le faire dans le délai indiqué, généralement cinq (5) jours ouvrés. La pièce et sa documentation doivent être retournées dans l'emballage fourni. Si vous ne retournez pas la pièce défectueuse, HP se réserve le droit de vous facturer les coûts de remplacement. Dans le cas d'une pièce CSR, HP supporte l'ensemble des frais d'expédition et de retour, et détermine la société de courses ou le transporteur à utiliser.

Pour plus d'informations sur le programme CSR de HP, contactez votre Mainteneur Agréé local. Pour plus d'informations sur ce programme en Amérique du Nord, consultez le site Web HP (<http://www.hp.com/go/selfrepair>).

Service de garantie "pièces seules"

Votre garantie limitée HP peut inclure un service de garantie "pièces seules". Dans ce cas, les pièces de rechange fournies par HP ne sont pas facturées.

Dans le cadre de ce service, la réparation des pièces CSR par le client est obligatoire. Si vous demandez à HP de remplacer ces pièces, les coûts de déplacement et main d'œuvre du service vous seront facturés.

Riparazione da parte del cliente

Per abbreviare i tempi di riparazione e garantire una maggiore flessibilità nella sostituzione di parti difettose, i prodotti HP sono realizzati con numerosi componenti che possono essere riparati direttamente dal cliente (CSR, Customer Self Repair). Se in fase di diagnostica HP (o un centro di servizi o di assistenza HP) identifica il guasto come riparabile mediante un ricambio CSR, HP lo spedisirà direttamente al cliente per la sostituzione. Vi sono due categorie di parti CSR:

- **Obbligatorie** – Parti che devono essere necessariamente riparate dal cliente. Se il cliente ne affida la riparazione ad HP, deve sostenere le spese di spedizione e di manodopera per il servizio.
- **Opzionali** – Parti la cui riparazione da parte del cliente è facultativa. Si tratta comunque di componenti progettati per questo scopo. Se tuttavia il cliente ne richiede la sostituzione ad HP, potrebbe dover sostenere spese addizionali a seconda del tipo di garanzia previsto per il prodotto.

NOTA: alcuni componenti HP non sono progettati per la riparazione da parte del cliente. Per rispettare la garanzia, HP richiede che queste parti siano sostituite da un centro di assistenza autorizzato. Tali parti sono identificate da un "No" nel Catalogo illustrato dei componenti.

In base alla disponibilità e alla località geografica, le parti CSR vengono spedite con consegna entro il giorno lavorativo seguente. La consegna nel giorno stesso o entro quattro ore è offerta con un supplemento di costo solo in alcune zone. In caso di necessità si può richiedere l'assistenza telefonica di un addetto del centro di supporto tecnico HP. Nel materiale fornito con una parte di ricambio CSR, HP specifica se il cliente deve restituire dei componenti. Qualora sia richiesta la resa ad HP del componente difettoso, lo si deve spedire ad HP entro un determinato periodo di tempo, generalmente cinque (5) giorni lavorativi. Il componente difettoso deve essere restituito con la documentazione associata nell'imballo di spedizione fornito. La mancata restituzione del componente può comportare la fatturazione del ricambio da parte di HP. Nel caso di riparazione da parte del cliente, HP sostiene tutte le spese di spedizione e resa e sceglie il corriere/vettore da utilizzare.

Per ulteriori informazioni sul programma CSR di HP contattare il centro di assistenza di zona. Per il programma in Nord America fare riferimento al sito Web HP (<http://www.hp.com/go/selfrepair>).

Servizio di garanzia per i soli componenti

La garanzia limitata HP può includere un servizio di garanzia per i soli componenti. Nei termini di garanzia del servizio per i soli componenti, HP fornirà gratuitamente le parti di ricambio.

Per il servizio di garanzia per i soli componenti è obbligatoria la formula CSR che prevede la riparazione da parte del cliente. Se il cliente invece richiede la sostituzione ad HP, dovrà sostenere le spese di spedizione e di manodopera per il servizio.

Customer Self Repair

HP Produkte enthalten viele CSR-Teile (Customer Self Repair), um Reparaturzeiten zu minimieren und höhere Flexibilität beim Austausch defekter Bauteile zu ermöglichen. Wenn HP (oder ein HP Servicepartner) bei der Diagnose feststellt, dass das Produkt mithilfe eines CSR-Teils repariert werden kann, sendet Ihnen HP dieses Bauteil zum Austausch direkt zu. CSR-Teile werden in zwei Kategorien unterteilt:

- **Zwingend** – Teile, für die das Customer Self Repair-Verfahren zwingend vorgegeben ist. Wenn Sie den Austausch dieser Teile von HP vornehmen lassen, werden Ihnen die Anfahrt- und Arbeitskosten für diesen Service berechnet.
- **Optional** – Teile, für die das Customer Self Repair-Verfahren optional ist. Diese Teile sind auch für Customer Self Repair ausgelegt. Wenn Sie jedoch den Austausch dieser Teile von HP vornehmen lassen möchten, können bei diesem Service je nach den für Ihr Produkt vorgesehenen Garantiebedingungen zusätzliche Kosten anfallen.

HINWEIS: Einige Teile sind nicht für Customer Self Repair ausgelegt. Um den Garantieanspruch des Kunden zu erfüllen, muss das Teil von einem HP Servicepartner ersetzt werden. Im illustrierten Teilekatalog sind diese Teile mit „No“ bzw. „Nein“ gekennzeichnet.

CSR-Teile werden abhängig von der Verfügbarkeit und vom Lieferziel am folgenden Geschäftstag geliefert. Für bestimmte Standorte ist eine Lieferung am selben Tag oder innerhalb von vier Stunden gegen einen Aufpreis verfügbar. Wenn Sie Hilfe benötigen, können Sie das HP technische Support Center

anrufen und sich von einem Mitarbeiter per Telefon helfen lassen. Den Materialien, die mit einem CSR-Ersatzteil geliefert werden, können Sie entnehmen, ob das defekte Teil an HP zurückgeschickt werden muss. Wenn es erforderlich ist, das defekte Teil an HP zurückzuschicken, müssen Sie dies innerhalb eines vorgegebenen Zeitraums tun, in der Regel innerhalb von fünf (5) Geschäftstagen. Das defekte Teil muss mit der zugehörigen Dokumentation in der Verpackung zurückgeschickt werden, die im Lieferumfang enthalten ist. Wenn Sie das defekte Teil nicht zurückschicken, kann HP Ihnen das Ersatzteil in Rechnung stellen. Im Falle von Customer Self Repair kommt HP für alle Kosten für die Lieferung und Rücksendung auf und bestimmt den Kurier-/Frachtdienst.

Weitere Informationen über das HP Customer Self Repair Programm erhalten Sie von Ihrem Servicepartner vor Ort. Informationen über das CSR-Programm in Nordamerika finden Sie auf der HP Website unter (<http://www.hp.com/go/selfrepair>).

Parts-only Warranty Service (Garantieservice ausschließlich für Teile)

Ihre HP Garantie umfasst möglicherweise einen Parts-only Warranty Service (Garantieservice ausschließlich für Teile). Gemäß den Bestimmungen des Parts-only Warranty Service stellt HP Ersatzteile kostenlos zur Verfügung.

Für den Parts-only Warranty Service ist das CSR-Verfahren zwingend vorgegeben. Wenn Sie den Austausch dieser Teile von HP vornehmen lassen, werden Ihnen die Anfahrt- und Arbeitskosten für diesen Service berechnet.

Reparaciones del propio cliente

Los productos de HP incluyen muchos componentes que el propio usuario puede reemplazar (*Customer Self Repair*, CSR) para minimizar el tiempo de reparación y ofrecer una mayor flexibilidad a la hora de realizar sustituciones de componentes defectuosos. Si, durante la fase de diagnóstico, HP (o los proveedores o socios de servicio de HP) identifica que una reparación puede llevarse a cabo mediante el uso de un componente CSR, HP le enviará dicho componente directamente para que realice su sustitución. Los componentes CSR se clasifican en dos categorías:

- **Obligatorio:** componentes para los que la reparación por parte del usuario es obligatoria. Si solicita a HP que realice la sustitución de estos componentes, tendrá que hacerse cargo de los gastos de desplazamiento y de mano de obra de dicho servicio.
- **Opcional:** componentes para los que la reparación por parte del usuario es opcional. Estos componentes también están diseñados para que puedan ser reparados por el usuario. Sin embargo, si precisa que HP realice su sustitución, puede o no conllevar costes adicionales, dependiendo del tipo de servicio de garantía correspondiente al producto.

NOTA: Algunos componentes no están diseñados para que puedan ser reparados por el usuario. Para que el usuario haga valer su garantía, HP pone como condición que un proveedor de servicios autorizado realice la sustitución de estos componentes. Dichos componentes se identifican con la palabra "No" en el catálogo ilustrado de componentes.

Según la disponibilidad y la situación geográfica, los componentes CSR se enviarán para que lleguen a su destino al siguiente día laborable. Si la situación geográfica lo permite, se puede solicitar la entrega en el mismo día o en cuatro horas con un coste adicional. Si precisa asistencia técnica, puede llamar al

Centro de asistencia técnica de HP y recibirá ayuda telefónica por parte de un técnico. Con el envío de materiales para la sustitución de componentes CSR, HP especificará si los componentes defectuosos deberán devolverse a HP. En aquellos casos en los que sea necesario devolver algún componente a HP, deberá hacerlo en el periodo de tiempo especificado, normalmente cinco días laborables. Los componentes defectuosos deberán devolverse con toda la documentación relacionada y con el embalaje de envío. Si no enviara el componente defectuoso requerido, HP podrá cobrarle por el de sustitución. En el caso de todas sustituciones que lleve a cabo el cliente, HP se hará cargo de todos los gastos de envío y devolución de componentes y escogerá la empresa de transporte que se utilice para dicho servicio.

Para obtener más información acerca del programa de Reparaciones del propio cliente de HP, póngase en contacto con su proveedor de servicios local. Si está interesado en el programa para Norteamérica, visite la página web de HP siguiente (<http://www.hp.com/go/selfrepair>).

Servicio de garantía exclusivo de componentes

La garantía limitada de HP puede que incluya un servicio de garantía exclusivo de componentes. Según las condiciones de este servicio exclusivo de componentes, HP le facilitará los componentes de repuesto sin cargo adicional alguno.

Para este servicio de garantía exclusivo de componentes, es obligatoria la sustitución de componentes por parte del usuario (CSR). Si solicita a HP que realice la sustitución de estos componentes, tendrá que hacerse cargo de los gastos de desplazamiento y de mano de obra de dicho servicio.

Customer Self Repair

Veel onderdelen in HP producten zijn door de klant zelf te repareren, waardoor de reparatieduur tot een minimum beperkt kan blijven en de flexibiliteit in het vervangen van defecte onderdelen groter is. Deze onderdelen worden CSR-onderdelen (Customer Self Repair) genoemd. Als HP (of een HP Service Partner) bij de diagnose vaststelt dat de reparatie kan worden uitgevoerd met een CSR-onderdeel, verzendt HP dat onderdeel rechtstreeks naar u, zodat u het defecte onderdeel daarmee kunt vervangen. Er zijn twee categorieën CSR-onderdelen:

- **Verplicht:** Onderdelen waarvoor reparatie door de klant verplicht is. Als u HP verzoekt deze onderdelen voor u te vervangen, worden u voor deze service reiskosten en arbeidsloon in rekening gebracht.
- **Optioneel:** Onderdelen waarvoor reparatie door de klant optioneel is. Ook deze onderdelen zijn ontworpen voor reparatie door de klant. Als u echter HP verzoekt deze onderdelen voor u te vervangen, kunnen daarvoor extra kosten in rekening worden gebracht, afhankelijk van het type garantieservice voor het product.

OPMERKING: Sommige HP onderdelen zijn niet ontwikkeld voor reparatie door de klant. In verband met de garantievooraarden moet het onderdeel door een geautoriseerde Service Partner worden vervangen. Deze onderdelen worden in de geïllustreerde onderdelencatalogus aangemerkt met "Nee".

Afhankelijk van de leverbaarheid en de locatie worden CSR-onderdelen verzonden voor levering op de eerstvolgende werkdag. Levering op dezelfde dag of binnen vier uur kan tegen meerkosten worden aangeboden, indien dit mogelijk is gezien de locatie. Indien assistentie gewenst is, belt u een HP Service Partner om via de telefoon technische ondersteuning te ontvangen. HP vermeldt in de documentatie bij het vervangende CSR-onderdeel of het defecte onderdeel aan HP moet worden geretourneerd. Als het defecte onderdeel aan HP moet worden teruggezonden, moet u het defecte onderdeel binnen een bepaalde

periode, gewoonlijk vijf (5) werkdagen, retourneren aan HP. Het defecte onderdeel moet met de bijbehorende documentatie worden geretourneerd in het meegeleverde verpakkingsmateriaal. Als u het defecte onderdeel niet terugzendt, kan HP u voor het vervangende onderdeel kosten in rekening brengen. Bij reparatie door de klant betaalt HP alle verzendkosten voor het vervangende en geretourneerde onderdeel en kiest HP zelf welke koerier/transportonderneming hiervoor wordt gebruikt.

Neem contact op met een Service Partner voor meer informatie over het Customer Self Repair programma van HP. Informatie over Service Partners vindt u op de HP website (<http://www.hp.nl/services/servicepartners>).

Garantieservice "Parts Only"

Het is mogelijk dat de HP garantie alleen de garantieservice "Parts Only" omvat. Volgens de bepalingen van de Parts Only garantieservice zal HP kosteloos vervangende onderdelen ter beschikking stellen.

Voor de Parts Only garantieservice is vervanging door CSR-onderdelen verplicht. Als u HP verzoekt deze onderdelen voor u te vervangen, worden u voor deze service reiskosten en arbeidsloon in rekening gebracht.

Reparo feito pelo cliente

Os produtos da HP são projetados com muitas peças para reparo feito pelo cliente (CSR) de modo a minimizar o tempo de reparo e permitir maior flexibilidade na substituição de peças com defeito. Se, durante o período de diagnóstico, a HP (ou fornecedores/parceiros de serviço da HP) concluir que o reparo pode ser efetuado pelo uso de uma peça CSR, a peça de reposição será enviada diretamente ao cliente. Existem duas categorias de peças CSR:

- **Obrigatória** – Peças cujo reparo feito pelo cliente é obrigatório. Se desejar que a HP substitua essas peças, serão cobradas as despesas de transporte e mão-de-obra do serviço.
- **Opcional** – Peças cujo reparo feito pelo cliente é opcional. Essas peças também são projetadas para o reparo feito pelo cliente. No entanto, se desejar que a HP as substitua, pode haver ou não a cobrança de taxa adicional, dependendo do tipo de serviço de garantia destinado ao produto.

OBSERVAÇÃO: Algumas peças da HP não são projetadas para o reparo feito pelo cliente. A fim de cumprir a garantia do cliente, a HP exige que um técnico autorizado substitua a peça. Essas peças estão identificadas com a marca "No" (Não), no catálogo de peças ilustrado.

Conforme a disponibilidade e o local geográfico, as peças CSR serão enviadas no primeiro dia útil após o pedido. Onde as condições geográficas permitirem, a entrega no mesmo dia ou em quatro horas pode ser feita mediante uma taxa adicional. Se precisar de auxílio, entre em contato com o Centro de suporte técnico da HP para que um técnico o ajude por telefone. A HP especifica nos materiais fornecidos com a peça CSR de reposição se a peça com defeito deve ser devolvida à HP. Nos casos em que isso for necessário, é preciso enviar a peça com defeito à HP dentro do período determinado, normalmente cinco (5) dias úteis. A peça com defeito deve ser enviada com a documentação correspondente no material de transporte fornecido. Caso não o faça, a HP poderá cobrar a reposição. Para as peças de reparo feito pelo cliente, a HP paga todas as despesas de transporte e de devolução da peça e determina a transportadora/serviço postal a ser utilizado.

Para obter mais informações sobre o programa de reparo feito pelo cliente da HP, entre em contato com o fornecedor de serviços local. Para o programa norte-americano, visite o site da HP (<http://www.hp.com/go/selfrepair>).

Serviço de garantia apenas para peças

A garantia limitada da HP pode incluir um serviço de garantia apenas para peças. Segundo os termos do serviço de garantia apenas para peças, a HP fornece as peças de reposição sem cobrar nenhuma taxa.

No caso desse serviço, a substituição de peças CSR é obrigatória. Se desejar que a HP substitua essas peças, serão cobradas as despesas de transporte e mão-de-obra do serviço.

顧客自己修理保証サービス

修理時間を短縮し、故障部品の交換における高い柔軟性を確保するために、HP製品には多数の顧客自己修理（CSR）部品があります。診断の際に、CSR部品を使用すれば修理ができるとHP（HPまたはHP正規保守代理店）が判断した場合、HPはその部品を直接、お客様に発送し、お客様に交換していただきます。CSR部品には以下の2通りがあります。

- 必須 - 顧客自己修理が必須の部品。当該部品について、もしもお客様がHPに交換作業を依頼される場合には、その修理サービスに関する交通費および人件費がお客様に請求されます。
- 任意 - 顧客自己修理が任意である部品。この部品も顧客自己修理用です。当該部品について、もしもお客様がHPに交換作業を依頼される場合には、お買い上げの製品に適用される保証サービス内容の範囲内においては、別途費用を負担していただくことなく保証サービスを受けることができます。

注： HP製品の一部の部品は、顧客自己修理用ではありません。製品の保証を継続するためには、HPまたはHP正規保守代理店による交換作業が必須となります。部品カタログには、当該部品が顧客自己修理除外品である旨が記載されています。

部品供給が可能な場合、地域によっては、CSR部品を翌営業日に届くように発送します。また、地域によっては、追加費用を負担いただくことにより同日または4時間以内に届くように発送することも可能な場合があります。サポートが必要なときは、HPの修理受付窓口にご連絡いただければ、技術者が電話でアドバイスします。交換用のCSR部品または同梱物には、故障部品をHPに返送する必要があるかどうかが表示されています。故障部品をHPに返送する必要がある場合は、指定期限内（通常は5営業日以内）に故障部品をHPに返送してください。故障部品を返送する場合は、届いた時の梱包箱に関連書類とともに入れてください。故障部品を返送しない場合、HPから部品費用が請求されます。顧客自己修理の際には、HPは送料および部品返送費を全額負担し、使用する宅配便会社や運送会社を指定します。

部品のみ保証サービス

HP保証サービスには、部品のみ保証サービスが適用される場合があります。このサービスでは、交換部品は無償で提供されます。

部品のみ保証サービスにおいては、CSR部品をお客様により交換作業していただくことが必須となります。当該部品について、もしもお客様がHPに交換作業を依頼される場合には、その修理サービスに関する交通費および人件費はお客様の負担となります。

客户自行维修

HP 产品提供许多客户自行维修 (CSR) 部件，以尽可能缩短维修时间和在更换缺陷部件方面提供更大的灵活性。如果在诊断期间 HP（或 HP 服务提供商或服务合作伙伴）确定可以通过使用 CSR 部件完成维修，HP 将直接把该部件发送给您进行更换。有两类 CSR 部件：

- **强制性的** — 要求客户必须自行维修的部件。如果您请求 HP 更换这些部件，则必须为该服务支付差旅费和人工费用。
- **可选的** — 客户可以选择是否自行维修的部件。这些部件也是为客户自行维修设计的。不过，如果您要求 HP 为您更换这些部件，则根据为您的产品指定的保修服务类型，HP 可能收取或不再收取任何附加费用。

注：某些 HP 部件的设计并未考虑客户自行维修。为了满足客户保修的需要，HP 要求授权服务提供商更换相关部件。这些部件在部件图解目录中标记为“否”。

CSR 部件将在下一个工作日发运（取决于备货情况和允许的地理范围）。在允许的地理范围内，可在当天或四小时内发运，但要收取额外费用。如果需要帮助，您可以致电 HP 技术支持中心，将会有技术人员通过电话为您提供帮助。HP 会在随更换的 CSR 部件发运的材料中指明是否必须将有缺陷的部件返还给 HP。如果要求您将缺陷的部件返还给 HP，那么您必须在规定期限内（通常是五 (5) 个工作日）将缺陷部件发给 HP。有缺陷的部件必须随所提供的发运材料中的相关文件一起返还。如果未能送还有缺陷的部件，HP 可能会要求您支付更换费用。客户自行维修时，HP 将承担所有相关运输和部件返回费用，并指定快递商/承运商。

有关 HP 客户自行维修计划的详细信息，请与您当地的服务提供商联系。有关北美地区的计划，请访问 HP 网站 (<http://www.hp.com/go/selfrepair>)。

仅部件保修服务

您的 HP 有限保修服务可能涉及仅部件保修服务。根据仅部件保修服务条款的规定，HP 将免费提供更换的部件。

仅部件保修服务要求进行 CSR 部件更换。如果您请求 HP 更换这些部件，则必须为该服务支付差旅费和人工费用。

客戶自行維修

HP 產品設計了許多「客戶自行維修」(CSR) 的零件以減少維修時間，並且使得更換瑕疵零件時能有更大的彈性。如果在診斷期間 HP (或 HP 服務供應商或維修夥伴) 辨認出此項維修工作可以藉由使用 CSR 零件來完成，則 HP 將直接寄送該零件給您作更換。CSR 零件分為兩種類別：

- **強制的** — 客戶自行維修所使用的零件是強制性的。如果您要求 HP 更換這些零件，HP 將會向您收取此服務所需的外出費用與勞動成本。
- **選購的** — 客戶自行維修所使用的零件是選購的。這些零件也設計用於客戶自行維修之用。不過，如果您要求 HP 為您更換，則可能需要也可能不需要負擔額外的費用，端視針對此產品指定的保固服務類型而定。

備註：某些 HP 零件沒有消費者可自行維修的設計。為符合客戶保固，HP 需要授權的服務供應商更換零件。這些零件在圖示的零件目錄中，被標示為「否」。

基於材料取得及環境允許的情況下，CSR 零件將於下一個工作日以快遞寄送。在環境的允許下當天或四小時內送達，則可能需要額外的費用。若您需要協助，可致電「HP 技術支援中心」，會有一位技術人員透過電話來協助您。不論損壞的零件是否必須退回，HP 皆會在與 CSR 替換零件一起運送的材料中註明。若要將損壞的零件退回 HP，您必須在指定的一段時間內（通常為五 (5) 個工作天），將損壞的零件寄回 HP。損壞的零件必須與寄送資料中隨附的相關技術文件一併退還。如果無法退還損壞的零件，HP 可能要向您收取替換費用。針對客戶自行維修情形，HP 將負責所有運費及零件退還費用並指定使用何家快遞/貨運公司。

如需 HP 的「客戶自行維修」方案詳細資訊，請連絡您當地的服務供應商。至於北美方案，請參閱 HP 網站 (<http://www.hp.com/go/selfrepair>)。

僅限零件的保固服務

您的「HP 有限保固」可能包含僅限零件的保固服務。在僅限零件的保固服務情況下，HP 將免費提供替換零件。

針對僅限零件的保固服務，CSR 零件替換是強制性的。如果您要求 HP 更換這些零件，HP 將會向您收取此服務所需的外出費用與勞動成本。

고객 셀프 수리

HP 제품은 수리 시간을 최소화하고 결함이 있는 부품 교체 시 더욱 융통성을 발휘할 수 있도록 하기 위해 고객 셀프 수리(CSR) 부품을 다량 사용하여 설계되었습니다. 진단 기간 동안 HP(또는 HP 서비스 공급업체 또는 서비스 협력업체)에서 CSR 부품을 사용하여 수리가 가능하다고 판단되면 HP는 해당 부품을 바로 사용자에게 보내어 사용자가 교체할 수 있도록 합니다. CSR 부품에는 두 가지 종류가 있습니다.

- **고객 셀프 수리가 의무 사항인 필수 부품.** 사용자가 HP에 이 부품의 교체를 요청할 경우 이 서비스에 대한 출장비 및 작업비가 청구됩니다.
- **고객 셀프 수리가 선택 사항인 부품.** 이 부품들도 고객 셀프 수리가 가능하도록 설계되었습니다. 하지만 사용자가 HP에 이 부품의 교체를 요청할 경우 사용자가 구입한 제품에 해당하는 보증 서비스 유형에 따라 추가 비용 없이 교체가 가능할 수 있습니다.

참고: 일부 HP 부품은 고객 셀프 수리가 불가능하도록 설계되었습니다. HP는 만족스러운 고객 보증을 위해 공인 서비스 제공업체를 통해 부품을 교체하도록 하고 있습니다. 이러한 부품들은 Illustrated Parts Catalog에 "No"라고 표시되어 있습니다.

CSR 부품은 재고 상태와 지리적 조건이 허용하는 경우 다음 영업일 납품이 가능하도록 배송이 이루어집니다. 지리적 조건이 허용하는 경우 추가 비용이 청구되는 조건으로 당일 또는 4시간 배송이 가능할 수도 있습니다. 도움이 필요하시면 HP 기술 지원 센터로 전화하십시오. 전문 기술자가 전화로 도움을 줄 것입니다. HP는 결함이 발생한 부품을 HP로 반환해야 하는지 여부를 CSR 교체 부품과 함께 배송된 자료에 지정합니다. 결함이 발생한 부품을 HP로 반환해야 하는 경우에는 지정된 기간 내(통상 영업일 기준 5일)에 HP로 반환해야 합니다. 이 때 결함이 발생한 부품은 제공된 포장 재료에 넣어 관련 설명서와 함께 반환해야 합니다. 결함이 발생한 부품을 반환하지 않는 경우 HP가 교체 부품에 대해 비용을 청구할 수 있습니다. 고객 셀프 수리의 경우, HP는 모든 운송 및 부품 반환 비용을 부담하며 이용할 운송업체 및 택배 서비스를 결정합니다.

HP 고객 셀프 수리 프로그램에 대한 자세한 내용은 가까운 서비스 제공업체에 문의하십시오. 북미 지역의 프로그램에 대해서는 HP 웹 사이트(<http://www.hp.com/go/selfrepair>)를 참조하십시오.

부품 제공 보증 서비스

HP 제한 보증에는 부품 제공 보증 서비스가 포함될 수 있습니다. 이러한 경우 HP는 부품 제공 보증 서비스의 조건에 따라 교체 부품만을 무료로 제공합니다.

부품 제공 보증 서비스 제공 시 CSR 부품 교체는 의무 사항입니다. 사용자가 HP에 이 부품의 교체를 요청할 경우 이 서비스에 대한 출장비 및 작업비가 청구됩니다.

Illustrated parts catalog

Mechanical components

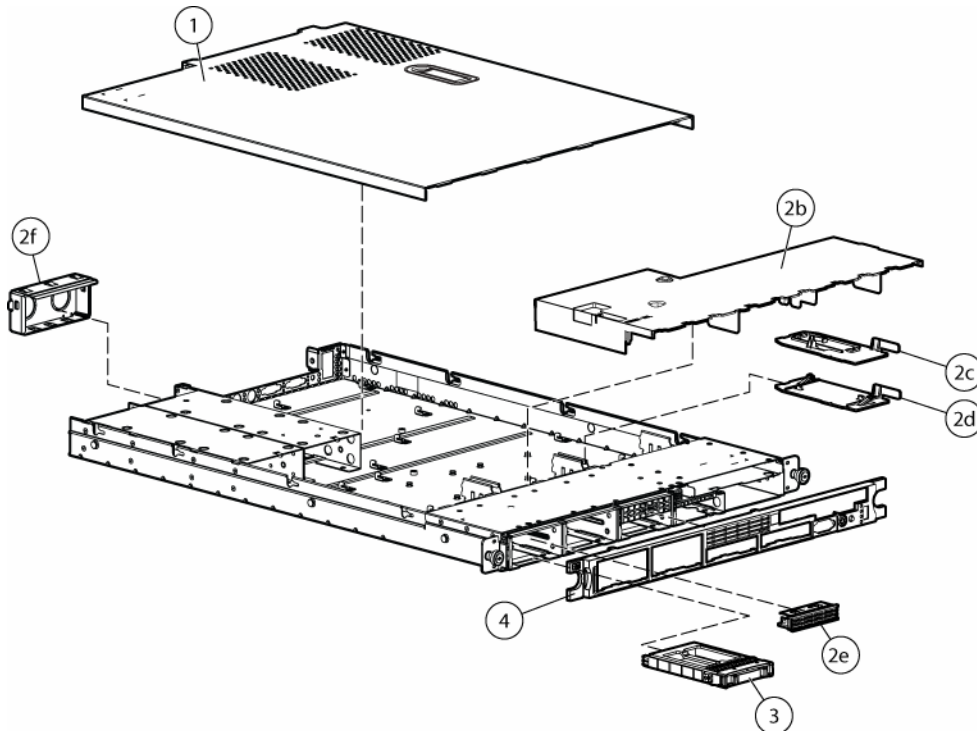

Item	Description	Spare part number	Customer self repair (on page 5)
1	Access panel	431360-001	Mandatory ¹
2	Miscellaneous hardware kit	431359-001	Mandatory ¹
	a) Optical device blank*	—	—
	b) Air baffle	—	—
	c) HP Smart Array E200i battery tray	—	—
	d) HP Smart Array P400i battery tray	—	—
	e) Hard drive bezel blank	—	—
	f) Power supply blank	—	—
3	Hard drive blank	392613-001	Mandatory ¹
4	Front bezel	—	—
	a) Standard front bezel	445865-001	Mandatory ¹
	b) Universal front bezel*	460692-001	Mandatory ¹

Item	Description	Spare part number	Customer self repair (on page 5)
	Rack mounting hardware		
5	Rack mounting hardware kit*	360104-001	Mandatory ¹
6	Cable management arm*	360105-001	Mandatory ¹

*Not shown

¹Mandatory—Parts for which customer self repair is mandatory. If you request HP to replace these parts, you will be charged for the travel and labor costs of this service.

²Optional—Parts for which customer self repair is optional. These parts are also designed for customer self repair. If, however, you require that HP replace them for you, there may or may not be additional charges, depending on the type of warranty service designated for your product.

³No—Some HP parts are not designed for customer self repair. In order to satisfy the customer warranty, HP requires that an authorized service provider replace the part. These parts are identified as "No" in the Illustrated Parts Catalog.

¹Mandatory: Obligatoire—Pièces pour lesquelles la réparation par le client est obligatoire. Si vous demandez à HP de remplacer ces pièces, les coûts de déplacement et main d'œuvre du service vous seront facturés.

²Optional: Facultatif—Pièces pour lesquelles la réparation par le client est facultative. Ces pièces sont également conçues pour permettre au client d'effectuer lui-même la réparation. Toutefois, si vous demandez à HP de remplacer ces pièces, l'intervention peut ou non vous être facturée, selon le type de garantie applicable à votre produit.

³No: Non—Certaines pièces HP ne sont pas conçues pour permettre au client d'effectuer lui-même la réparation. Pour que la garantie puisse s'appliquer, HP exige que le remplacement de la pièce soit effectué par un Mainteneur Agréé. Ces pièces sont identifiées par la mention "Non" dans le Catalogue illustré.

¹Mandatory: Obbligatorie—Parti che devono essere necessariamente riparate dal cliente. Se il cliente ne affida la riparazione ad HP, deve sostenere le spese di spedizione e di manodopera per il servizio.

²Optional: Opzionali—Parti la cui riparazione da parte del cliente è facoltativa. Si tratta comunque di componenti progettati per questo scopo. Se tuttavia il cliente ne richiede la sostituzione ad HP, potrebbe dover sostenere spese aggiuntive a seconda del tipo di garanzia previsto per il prodotto.

³No: Non CSR—Alcuni componenti HP non sono progettati per la riparazione da parte del cliente. Per rispettare la garanzia, HP richiede che queste parti siano sostituite da un centro di assistenza autorizzato. Tali parti sono identificate da un "No" nel Catalogo illustrato dei componenti.

¹Mandatory: Zwingend—Teile, die im Rahmen des Customer Self Repair Programms ersetzt werden müssen. Wenn Sie diese Teile von HP ersetzen lassen, werden Ihnen die Versand- und Arbeitskosten für diesen Service berechnet.

²Optional: Optional—Teile, für die das Customer Self Repair-Verfahren optional ist. Diese Teile sind auch für Customer Self Repair ausgelegt. Wenn Sie jedoch den Austausch dieser Teile von HP vornehmen lassen möchten, können bei diesem Service je nach den für Ihr Produkt vorgesehenen Garantiebedingungen zusätzliche Kosten anfallen.

³No: Kein—Einige Teile sind nicht für Customer Self Repair ausgelegt. Um den Garantieanspruch des Kunden zu erfüllen, muss das Teil von einem HP Servicepartner ersetzt werden. Im illustrierten Teilekatalog sind diese Teile mit „No“ bzw. „Nein“ gekennzeichnet.

¹Mandatory: Obligatorio—componentes para los que la reparación por parte del usuario es obligatoria. Si solicita a HP que realice la sustitución de estos componentes, tendrá que hacerse cargo de los gastos de desplazamiento y de mano de obra de dicho servicio.

²Optional: Opcional— componentes para los que la reparación por parte del usuario es opcional. Estos componentes también están diseñados para que puedan ser reparados por el usuario. Sin embargo, si precisa que HP realice su sustitución, puede o no conllevar costes adicionales, dependiendo del tipo de servicio de garantía correspondiente al producto.

³No: No—Algunos componentes no están diseñados para que puedan ser reparados por el usuario. Para que el usuario haga valer su garantía, HP pone como condición que un proveedor de servicios autorizado realice la

sustitución de estos componentes. Dichos componentes se identifican con la palabra "No" en el catálogo ilustrado de componentes.

¹Mandatory: Verplicht—Onderdelen waarvoor Customer Self Repair verplicht is. Als u HP verzoekt deze onderdelen te vervangen, komen de reiskosten en het arbeidsloon voor uw rekening.

²Optional: Optioneel—Onderdelen waarvoor reparatie door de klant optioneel is. Ook deze onderdelen zijn ontworpen voor reparatie door de klant. Als u echter HP verzoekt deze onderdelen voor u te vervangen, kunnen daarvoor extra kosten in rekening worden gebracht, afhankelijk van het type garantieservice voor het product.

³No: Nee—Sommige HP onderdelen zijn niet ontwikkeld voor reparatie door de klant. In verband met de garantievoorzwaarden moet het onderdeel door een geautoriseerde Service Partner worden vervangen. Deze onderdelen worden in de geïllustreerde onderdelencatalogus aangemerkt met "Nee".

¹Mandatory: Obrigatória—Peças cujo reparo feito pelo cliente é obrigatório. Se desejar que a HP substitua essas peças, serão cobradas as despesas de transporte e mão-de-obra do serviço.

²Optional: Opcional—Peças cujo reparo feito pelo cliente é opcional. Essas peças também são projetadas para o reparo feito pelo cliente. No entanto, se desejar que a HP as substitua, pode haver ou não a cobrança de taxa adicional, dependendo do tipo de serviço de garantia destinado ao produto.

³No: Nenhuma—Algumas peças da HP não são projetadas para o reparo feito pelo cliente. A fim de cumprir a garantia do cliente, a HP exige que um técnico autorizado substitua a peça. Essas peças estão identificadas com a marca "No" (Não), no catálogo de peças ilustrado.

¹Mandatory : 必須 - 顧客自己修理が必須の部品。当該部品について、もしもお客様がHPに交換作業を依頼される場合には、その修理サービスに関する交通費および人件費がお客様に請求されます。

²Optional : 任意 - 顧客自己修理が任意である部品。この部品も顧客自己修理用です。当該部品について、もしもお客様がHPに交換作業を依頼される場合には、お買い上げの製品に適用される保証サービス内容の範囲内においては、費用を負担していただくことなく保証サービスを受けることができます。

³No : 除外 - HP製品の一部の部品は、顧客自己修理用ではありません。製品の保証を継続するためには、HPまたはHP正規保守代理店による交換作業が必須となります。部品カタログには、当該部品が顧客自己修理除外品である旨が記載されています。

¹Mandatory: 强制性的 — 要求客户必须自行维修的部件。如果您请求 HP 更换这些部件，则必须为该服务支付差旅费和人工费用。

²Optional: 可选的 — 客户可以选择是否自行维修的部件。这些部件也是为客户自行维修设计的。不过，如果您要求 HP 为您更换这些部件，则根据为您的产品指定的保修服务类型，HP 可能收取或不再收取任何附加费用。

³No: 否 — 某些 HP 部件的设计并未考虑客户自行维修。为了满足客户保修的需要，HP 要求授权服务提供商更换相关部件。这些部件在部件图解目录中标记为“否”。

¹Mandatory: 强制的 — 客户自行维修所使用的零件是强制性的。如果您要求 HP 更换这些零件，HP 将会向您收取此服务所需的外出费用与劳动成本。

²Optional: 選購的 — 客户自行维修所使用的零件是選購的。這些零件也設計用於客戶自行維修之用。不過，如果您要求 HP 為您更換，則可能需要也可能不需要負擔額外的費用，端視針對此產品指定的保固服務類型而定。

³No: 否 — 某些 HP 零件沒有消費者可自行維修的設計。為符合客戶保固，HP 需要授權的服務供應商更換零件。這些零件在圖示的零件目錄中，被標示為「否」。

¹ Mandatory: 필수 — 고객 셀프 수리가 의무 사항인 필수 부품. 사용자가 HP에 이 부품의 교체를 요청할 경우 이 서비스에 대한 출장비 및 작업비가 청구됩니다.

² Optional: 옵션 — 고객 셀프 수리가 선택 사항인 부품. 이 부품들도 고객 셀프 수리가 가능하도록 설계되었습니다. 하지만 사용자가 HP에 이 부품의 교체를 요청할 경우 사용자가 구입한 제품에 해당하는 보증 서비스 유형에 따라 추가 비용 없이 교체가 가능할 수 있습니다.

³ No: No — 고객 셀프 수리가 불가능하도록 설계된 HP 부품. 이 부품들은 고객 셀프 수리가 불가능하도록 설계되었습니다. HP는 고객 보증을 만족시키기 위해 공인 서비스 제공업체를 통해 부품을 교체하도록 하고 있습니다.

System components

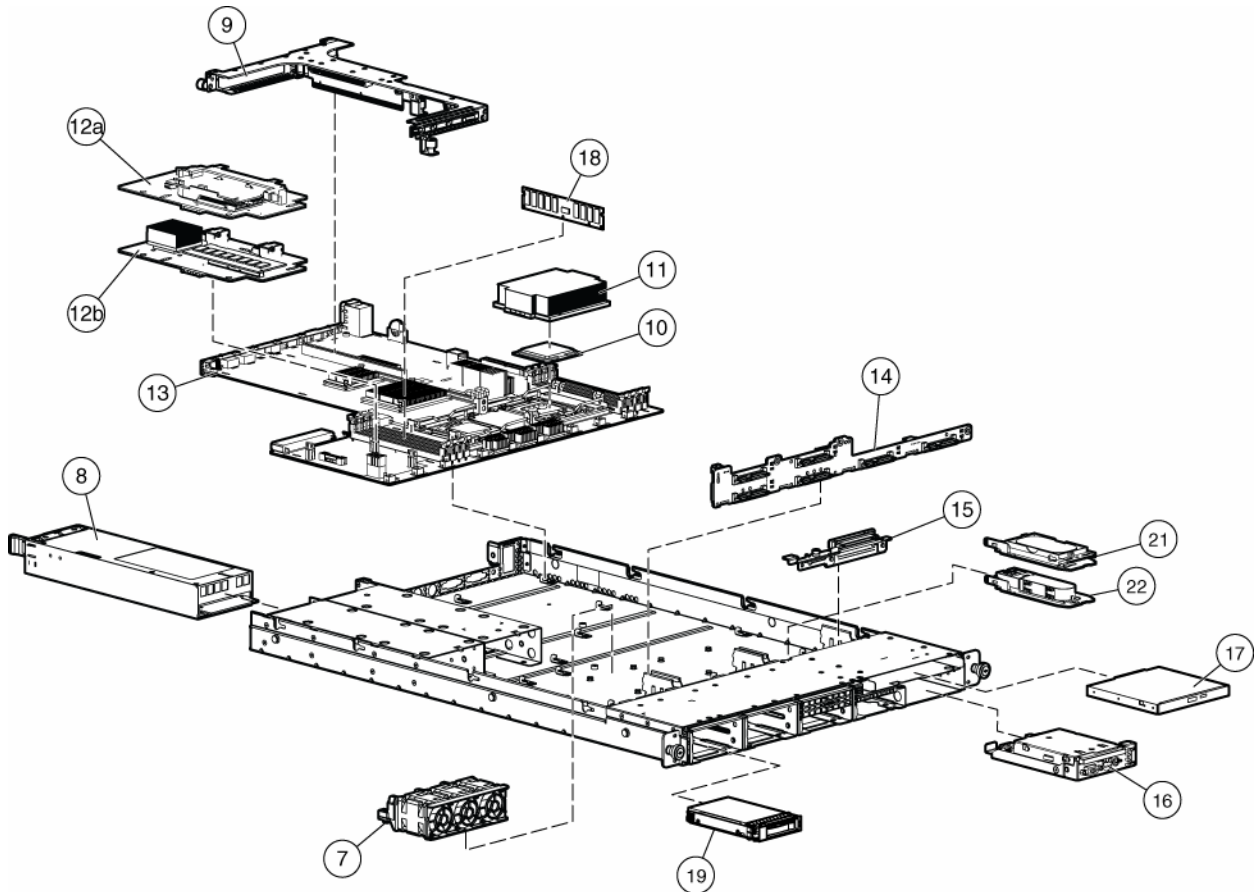

Item	Description	Spare part number	Customer self repair (on page 5)
7	System fan module	412212-001	Mandatory ¹
8	Hot-plug power supply, 700-W	412211-001	Mandatory ¹
9	PCIe riser board assembly	412200-001	Mandatory ¹
10	Processor	—	—
	a) 1.8-GHz, 95-W AMD Opteron™	419473-001	Optional ²
	b) 2.4-GHz, 95-W AMD Opteron™*	419478-001	Optional ²
	c) 2.6-GHz, 95-W AMD Opteron™*	419480-001	Optional ²
	d) 2.8-GHz, 95-W AMD Opteron™*	439749-001	Optional ²
	e) 1.8-GHz, 68-W AMD Opteron™*	434949-001	Optional ²
	f) 2.1-GHz, 95-W AMD Opteron™*	446384-103	Optional ²
	g) 2.2-GHz, 68-W AMD Opteron™*	419477-001	Optional ²
	h) 2.2-GHz, 95-W AMD Opteron™*	446384-102	Optional ²
	i) 2.4-GHz, 68-W AMD Opteron™*	419479-001	Optional ²
	j) 2.6-GHz, 68-W AMD Opteron™*	439750-001	Optional ²

Item	Description	Spare part number	Customer self repair (on page 5)
	k) 3.0-GHz, 95-W AMD Opteron™*	451810-001	Optional ²
11	Heatsink with grease and alcohol swab	431356-001	Optional ²
	Boards		
12	HP Smart Array controllers	—	—
	a) HP Smart Array E200i Controller, integrated SAS	412205-001	Mandatory ¹
	b) HP Smart Array P400i Controller, integrated SAS	412206-001	Mandatory ¹
13	System board with processor cages	431355-001	Optional ²
14	SAS backplane	412201-001	Optional ²
15	Multibay media backplane	412202-001	Mandatory ¹
16	HP Systems Insight Display, LEDs, and power button assembly, with cable	431358-001	Optional ²
	Media devices		
17	Multibay drives	—	—
	a) CD-RW combo drive, removable multibay, IDE, 24X	399959-001	Mandatory ¹
	b) DVD-ROM+RW drive, removable multibay, 8X*	397928-001	Mandatory ¹
	c) Diskette drive, removable multibay*	399396-001	Mandatory ¹
	Memory		
18	DIMM, PC2-5300 registered DDR2	—	—
	a) 512-MB*	430449-001	Mandatory ¹
	b) 1-GB*	430450-001	Mandatory ¹
	c) 2-GB*	432668-001	Mandatory ¹
	d) 4-GB*	432670-001	Mandatory ¹
	Hard drives		
19	SAS hard drives	—	—
	a) 36-GB, 10,000-rpm	376596-001	Mandatory ¹
	b) 72-GB, 10,000-rpm*	376597-001	Mandatory ¹
	c) 146-GB, 10,000-rpm*	432320-001	Mandatory ¹
20	60-GB SATA hard drive, 5,400-rpm*	405419-001	Mandatory ¹
	BBWC		
21	HP Smart Array E200i battery pack	307132-001	Optional ²
22	HP Smart Array P400i battery pack	398648-001	Optional ²
23	HP Smart Array E200i memory module, 64-MB*	412800-001	Optional ²
24	HP Smart Array E200i memory module, 128-MB*	413486-001	Optional ²
25	HP Smart Array P400i memory module, 256-MB*	405836-001	Optional ²
26	HP Smart Array P400i memory module, 512-MB*	405835-001	Optional ²

Item	Description	Spare part number	Customer self repair (on page 5)
	Miscellaneous		
27	SAS cable*	408763-001	Mandatory ¹
28	Smart Array battery cable*	409124-001	Mandatory ¹
29	AC power cord*	142258-001	Mandatory ¹
30	Battery, 3.3-V, lithium*	234556-001	Mandatory ¹

*Not shown

¹Mandatory—Parts for which customer self repair is mandatory. If you request HP to replace these parts, you will be charged for the travel and labor costs of this service.

²Optional—Parts for which customer self repair is optional. These parts are also designed for customer self repair. If, however, you require that HP replace them for you, there may or may not be additional charges, depending on the type of warranty service designated for your product.

³No—Some HP parts are not designed for customer self repair. In order to satisfy the customer warranty, HP requires that an authorized service provider replace the part. These parts are identified as "No" in the Illustrated Parts Catalog.

¹Mandatory: Obligatoire—Pièces pour lesquelles la réparation par le client est obligatoire. Si vous demandez à HP de remplacer ces pièces, les coûts de déplacement et main d'œuvre du service vous seront facturés.

²Optional: Facultatif—Pièces pour lesquelles la réparation par le client est facultative. Ces pièces sont également conçues pour permettre au client d'effectuer lui-même la réparation. Toutefois, si vous demandez à HP de remplacer ces pièces, l'intervention peut ou non vous être facturée, selon le type de garantie applicable à votre produit.

³No: Non—Certaines pièces HP ne sont pas conçues pour permettre au client d'effectuer lui-même la réparation. Pour que la garantie puisse s'appliquer, HP exige que le remplacement de la pièce soit effectué par un Mainteneur Agréé. Ces pièces sont identifiées par la mention "Non" dans le Catalogue illustré.

¹Mandatory: Obbligatorie—Parti che devono essere necessariamente riparate dal cliente. Se il cliente ne affida la riparazione ad HP, deve sostenere le spese di spedizione e di manodopera per il servizio.

²Optional: Opzionali—Parti la cui riparazione da parte del cliente è facoltativa. Si tratta comunque di componenti progettati per questo scopo. Se tuttavia il cliente ne richiede la sostituzione ad HP, potrebbe dover sostenere spese aggiuntive a seconda del tipo di garanzia previsto per il prodotto.

³No: Non CSR—Alcuni componenti HP non sono progettati per la riparazione da parte del cliente. Per rispettare la garanzia, HP richiede che queste parti siano sostituite da un centro di assistenza autorizzato. Tali parti sono identificate da un "No" nel Catalogo illustrato dei componenti.

¹Mandatory: Zwingend—Teile, die im Rahmen des Customer Self Repair Programms ersetzt werden müssen. Wenn Sie diese Teile von HP ersetzen lassen, werden Ihnen die Versand- und Arbeitskosten für diesen Service berechnet.

²Optional: Optional—Teile, für die das Customer Self Repair-Verfahren optional ist. Diese Teile sind auch für Customer Self Repair ausgelegt. Wenn Sie jedoch den Austausch dieser Teile von HP vornehmen lassen möchten, können bei diesem Service je nach den für Ihr Produkt vorgesehenen Garantiebedingungen zusätzliche Kosten anfallen.

³No: Kein—Einige Teile sind nicht für Customer Self Repair ausgelegt. Um den Garantieanspruch des Kunden zu erfüllen, muss das Teil von einem HP Servicepartner ersetzt werden. Im illustrierten Teilekatalog sind diese Teile mit „No“ bzw. „Nein“ gekennzeichnet.

¹Mandatory: Obligatorio—componentes para los que la reparación por parte del usuario es obligatoria. Si solicita a HP que realice la sustitución de estos componentes, tendrá que hacerse cargo de los gastos de desplazamiento y de mano de obra de dicho servicio.

²Optional: Opcional— componentes para los que la reparación por parte del usuario es opcional. Estos componentes también están diseñados para que puedan ser reparados por el usuario. Sin embargo, si precisa que HP realice su sustitución, puede o no conllevar costes adicionales, dependiendo del tipo de servicio de garantía correspondiente al producto.

³No: No—Algunos componentes no están diseñados para que puedan ser reparados por el usuario. Para que el usuario haga valer su garantía, HP pone como condición que un proveedor de servicios autorizado realice la sustitución de estos componentes. Dichos componentes se identifican con la palabra “No” en el catálogo ilustrado de componentes.

¹Mandatory: Verplicht—Onderdelen waarvoor Customer Self Repair verplicht is. Als u HP verzoekt deze onderdelen te vervangen, komen de reiskosten en het arbeidsloon voor uw rekening.

²Optional: Optioneel—Onderdelen waarvoor reparatie door de klant optioneel is. Ook deze onderdelen zijn ontworpen voor reparatie door de klant. Als u echter HP verzoekt deze onderdelen voor u te vervangen, kunnen daarvoor extra kosten in rekening worden gebracht, afhankelijk van het type garantieservice voor het product.

³No: Nee—Sommige HP onderdelen zijn niet ontwikkeld voor reparatie door de klant. In verband met de garantievoorwaarden moet het onderdeel door een geautoriseerde Service Partner worden vervangen. Deze onderdelen worden in de geïllustreerde onderdelencatalogus aangemerkt met "Nee".

¹Mandatory: Obrigatória—Peças cujo reparo feito pelo cliente é obrigatório. Se desejar que a HP substitua essas peças, serão cobradas as despesas de transporte e mão-de-obra do serviço.

²Optional: Opcional—Peças cujo reparo feito pelo cliente é opcional. Essas peças também são projetadas para o reparo feito pelo cliente. No entanto, se desejar que a HP as substitua, pode haver ou não a cobrança de taxa adicional, dependendo do tipo de serviço de garantia destinado ao produto.

³No: Nenhuma—Algumas peças da HP não são projetadas para o reparo feito pelo cliente. A fim de cumprir a garantia do cliente, a HP exige que um técnico autorizado substitua a peça. Essas peças estão identificadas com a marca “No” (Não), no catálogo de peças ilustrado.

¹Mandatory : 必須 - 顧客自己修理が必須の部品。当該部品について、もしもお客様がHPに交換作業を依頼される場合には、その修理サービスに関する交通費および人件費がお客様に請求されます。

²Optional : 任意 - 顧客自己修理が任意である部品。この部品も顧客自己修理用です。当該部品について、もしもお客様がHPに交換作業を依頼される場合には、お買い上げの製品に適用される保証サービス内容の範囲内においては、費用を負担していただくことなく保証サービスを受けることができます。

³No : 除外 - HP製品の一部の部品は、顧客自己修理用ではありません。製品の保証を継続するためには、HPまたはHP正規保守代理店による交換作業が必須となります。部品カタログには、当該部品が顧客自己修理除外品である旨が記載されています。

¹Mandatory: 强制性的 — 要求客户必须自行维修的部件。如果您请求 HP 更换这些部件，则必须为该服务支付差旅费和人工费用。

²Optional: 可选的 — 客户可以选择是否自行维修的部件。这些部件也是为客户自行维修设计的。不过，如果您要求 HP 为您更换这些部件，则根据为您的产品指定的保修服务类型，HP 可能收取或不再收取任何附加费用。

³No: 否 — 某些 HP 部件的设计并未考虑客户自行维修。为了满足客户保修的需要，HP 要求授权服务提供商更换相关部件。这些部件在部件图解目录中标记为“否”。

¹Mandatory: 强制的 — 客户自行维修所使用的零件是强制性的。如果您要求 HP 更换这些零件，HP 将会向您收取此服务所需的外出费用与劳动成本。

²Optional: 選購的 — 客户自行维修所使用的零件是選購的。這些零件也設計用於客戶自行維修之用。不過，如果您要求 HP 為您更換，則可能需要也可能不需要負擔額外的費用，端視針對此產品指定的保固服務類型而定。

³No: 否 — 某些 HP 零件沒有消費者可自行維修的設計。為符合客戶保固，HP 需要授權的服務供應商更換零件。這些零件在圖示的零件目錄中，被標示為「否」。

¹ Mandatory: 필수 — 고객 셀프 수리가 의무 사항인 필수 부품. 사용자가 HP에 이 부품의 교체를 요청할 경우 이 서비스에 대한 출장비 및 작업비가 청구됩니다.

² Optional: 옵션 — 고객 셀프 수리가 선택 사항인 부품. 이 부품들도 고객 셀프 수리가 가능하도록 설계되었습니다. 하지만 사용자가 HP에 이 부품의 교체를 요청할 경우 사용자가 구입한 제품에 해당하는 보증 서비스 유형에 따라 추가 비용 없이 교체가 가능할 수 있습니다.

³ No: No — 고객 셀프 수리가 불가능하도록 설계된 HP 부품. 이 부품들은 고객 셀프 수리가 불가능하도록 설계되었습니다. HP는 고객 보증을 만족시키기 위해 공인 서비스 제공업체를 통해 부품을 교체하도록 하고 있습니다.

Removal and replacement procedures

Required tools

You need the following items for some procedures:

- T-10 Torx screwdriver
- T-15 Torx screwdriver
- Diagnostics Utility

Safety considerations

Before performing service procedures, review all the safety information.

Preventing electrostatic discharge

To prevent damaging the system, be aware of the precautions you need to follow when setting up the system or handling parts. A discharge of static electricity from a finger or other conductor may damage system boards or other static-sensitive devices. This type of damage may reduce the life expectancy of the device.

To prevent electrostatic damage:

- Avoid hand contact by transporting and storing products in static-safe containers.
- Keep electrostatic-sensitive parts in their containers until they arrive at static-free workstations.
- Place parts on a grounded surface before removing them from their containers.
- Avoid touching pins, leads, or circuitry.
- Always be properly grounded when touching a static-sensitive component or assembly.

Symbols on equipment

The following symbols may be placed on equipment to indicate the presence of potentially hazardous conditions.



This symbol indicates the presence of hazardous energy circuits or electric shock hazards. Refer all servicing to qualified personnel.

WARNING: To reduce the risk of injury from electric shock hazards, do not open this enclosure. Refer all maintenance, upgrades, and servicing to qualified personnel.



This symbol indicates the presence of electric shock hazards. The area contains no user or field serviceable parts. Do not open for any reason.

WARNING: To reduce the risk of injury from electric shock hazards, do not open this enclosure.



This symbol on an RJ-45 receptacle indicates a network interface connection.

WARNING: To reduce the risk of electric shock, fire, or damage to the equipment, do not plug telephone or telecommunications connectors into this receptacle.



This symbol indicates the presence of a hot surface or hot component. If this surface is contacted, the potential for injury exists.

WARNING: To reduce the risk of injury from a hot component, allow the surface to cool before touching.



14.06 - 17.92 kg
31.00 - 39.50 lb

This symbol indicates that the component exceeds the recommended weight for one individual to handle safely.

WARNING: To reduce the risk of personal injury or damage to the equipment, observe local occupational health and safety requirements and guidelines for manual material handling.



These symbols, on power supplies or systems, indicate that the equipment is supplied by multiple sources of power.

WARNING: To reduce the risk of injury from electric shock, remove all power cords to completely disconnect power from the system.

Server warnings and cautions

Before installing a server, be sure that you understand the following warnings and cautions.



WARNING: To reduce the risk of electric shock or damage to the equipment:

- Do not disable the power cord grounding plug. The grounding plug is an important safety feature.
- Plug the power cord into a grounded (earthed) electrical outlet that is easily accessible at all times.
- Unplug the power cord from the power supply to disconnect power to the equipment.
- Do not route the power cord where it can be walked on or pinched by items placed against it. Pay particular attention to the plug, electrical outlet, and the point where the cord extends from the server.



WARNING: To reduce the risk of personal injury from hot surfaces, allow the drives and the internal system components to cool before touching them.



CAUTION: Do not operate the server for long periods with the access panel open or removed. Operating the server in this manner results in improper airflow and improper cooling that can lead to thermal damage.

Preparation procedures

To access some components and perform certain service procedures, you must perform one or more of the following procedures:

- Extend the server from the rack (on page 25).
If you are performing service procedures in an HP, Compaq branded, telco, or third-party rack cabinet, you can use the locking feature of the rack rails to support the server and gain access to internal components.
For more information about telco rack solutions, refer to the RackSolutions.com website (<http://www.racksolutions.com/hp>).
- Power down the server (on page 25).
If you must remove a server from a rack or a non-hot-plug component from a server, power down the server.
- Remove the server from the rack (on page 26).
If the rack environment, cabling configuration, or the server location in the rack creates awkward conditions, remove the server from the rack.

Extend the server from the rack

NOTE: If the optional cable management arm option is installed, you can extend the server without powering down the server or disconnecting peripheral cables and power cords. These steps are only necessary with the standard cable management solution.

1. Power down the server (on page 25).
2. Disconnect all peripheral cables and power cords.
3. Loosen the front panel thumbscrews.
4. Extend the server on the rack rails until the server rail-release latches engage.

 **WARNING:** To reduce the risk of personal injury or equipment damage, be sure that the rack is adequately stabilized before extending a component from the rack.

 **WARNING:** To reduce the risk of personal injury, be careful when pressing the server rail-release latches and sliding the server into the rack. The sliding rails could pinch your fingers.

5. After performing the installation or maintenance procedure, slide the server into the rack:
 - a. Slide the server fully into the rack.
 - b. Secure the server by tightening the thumbscrews.
6. Connect the peripheral cables and power cords.

Power down the server

 **WARNING:** To reduce the risk of personal injury, electric shock, or damage to the equipment, remove the power cord to remove power from the server. The front panel Power On/Standby button does not completely shut off system power. Portions of the power supply and some internal circuitry remain active until AC power is removed.



IMPORTANT: If installing a hot-plug device, it is not necessary to power down the server.

1. Back up the server data.
2. Shut down the operating system as directed by the operating system documentation.
3. If the server is installed in a rack, press the UID LED button on the front panel. Blue LEDs illuminate on the front and rear panels of the server.
4. Press the Power On/Standby button to place the server in standby mode. When the server activates standby power mode, the system power LED changes to amber.
5. If the server is installed in a rack, locate the server by identifying the illuminated rear UID LED button.
6. Disconnect the power cords.

The system is now without power.

Remove the server from the rack

To remove the server from an HP, Compaq branded, telco, or third-party rack:

1. Power down the server (on page 25).
2. Extend the server from the rack (on page 25).
3. Disconnect the cabling and remove the server from the rack. For more information, refer to the documentation that ships with the rack mounting option.
4. Place the server on a sturdy, level surface.

Hard drive blanks



CAUTION: To prevent improper cooling and thermal damage, do not operate the server unless all bays are populated with either a component or a blank.

Remove the component as indicated.

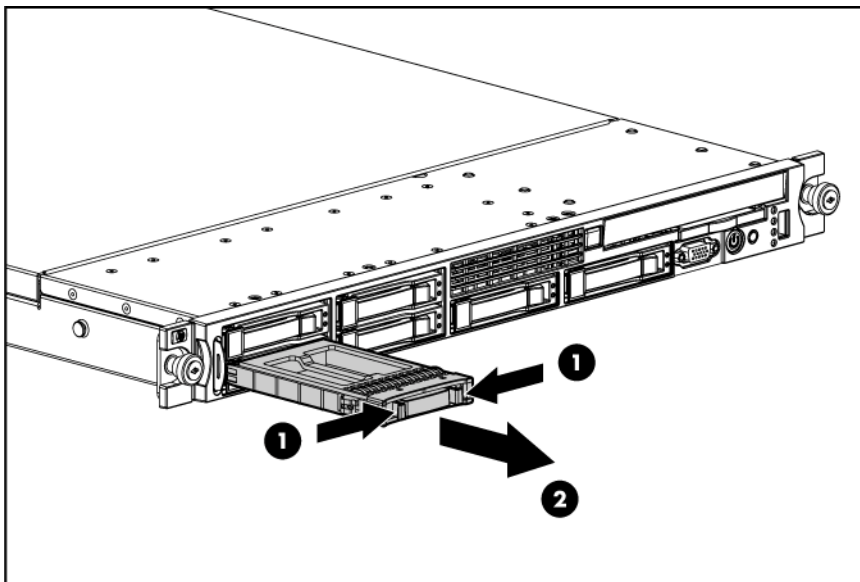

To replace the component, reverse the removal procedure.

Hot-plug SAS or SATA hard drives

△ **CAUTION:** To prevent improper cooling and thermal damage, do not operate the server unless all bays are populated with either a component or a blank.

Remove the component as indicated.

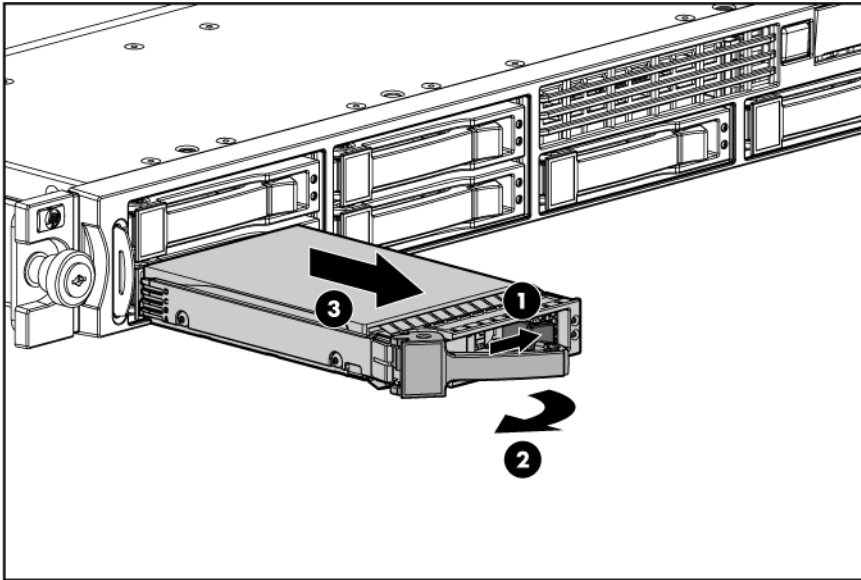

To replace the component, reverse the removal procedure.

Front bezel

1. Power down the server (on page [25](#)).
2. Extend the server from the rack (on page [25](#)).
3. Remove all hard drives ("[Hot-plug SAS or SATA hard drives](#)" on page [27](#)) and hard drive blanks ("[Hard drive blanks](#)" on page [26](#)).
4. Remove the serial label pull tab by extending it out, and then pressing on the underside to release it from the chassis.
5. Remove the T-10 Torx screws located on the top of the bezel.

6. Remove the T-10 Torx screws located on the sides of the bezel.

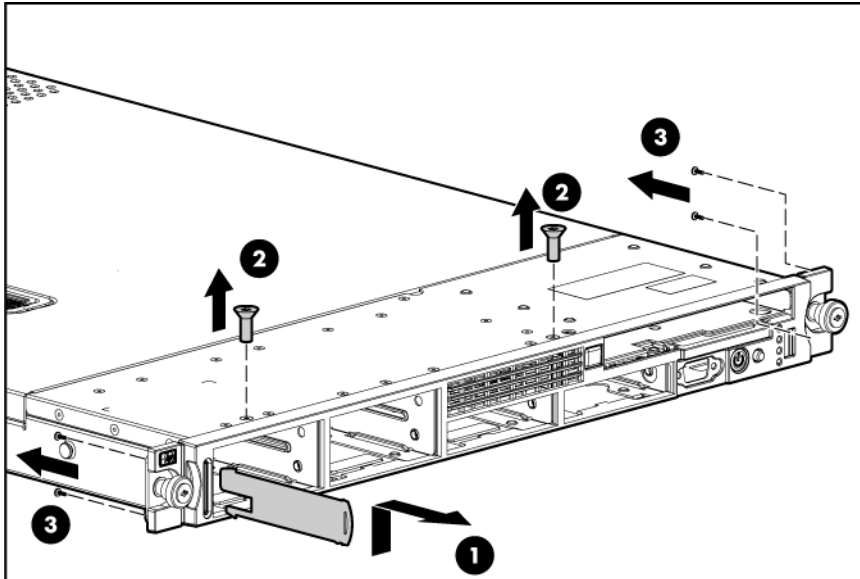

7. Gently push on the two tabs located at the top of the bezel
8. Rotate the bezel away from the server and remove the bezel.

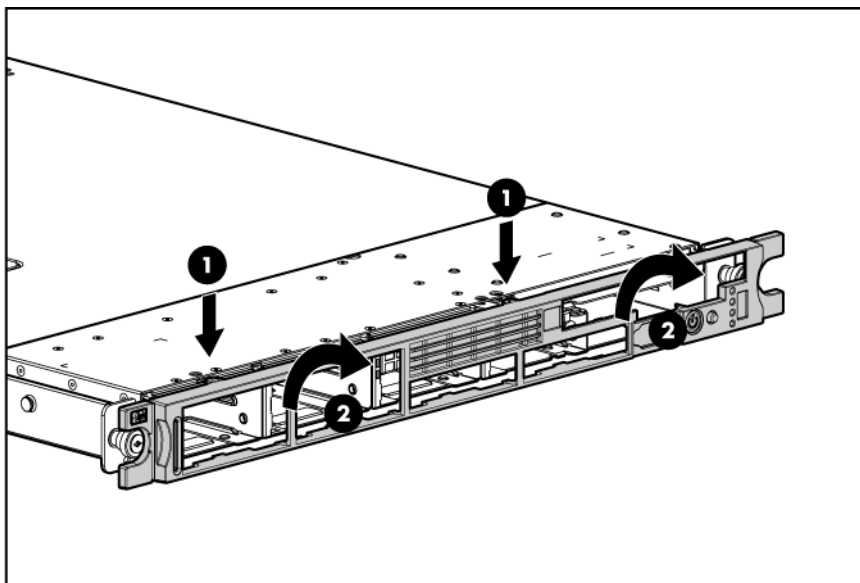

To replace the component, reverse the removal procedure.

Hard drive bezel blanks

CAUTION: To prevent improper cooling and thermal damage, do not operate the server unless all bays are populated with either a component or a blank.

To remove the component:

1. Remove hard drives 1 and 2 ("[Hot-plug SAS or SATA hard drives](#)" on page 27).

2. Remove the hard drive bezel blank.

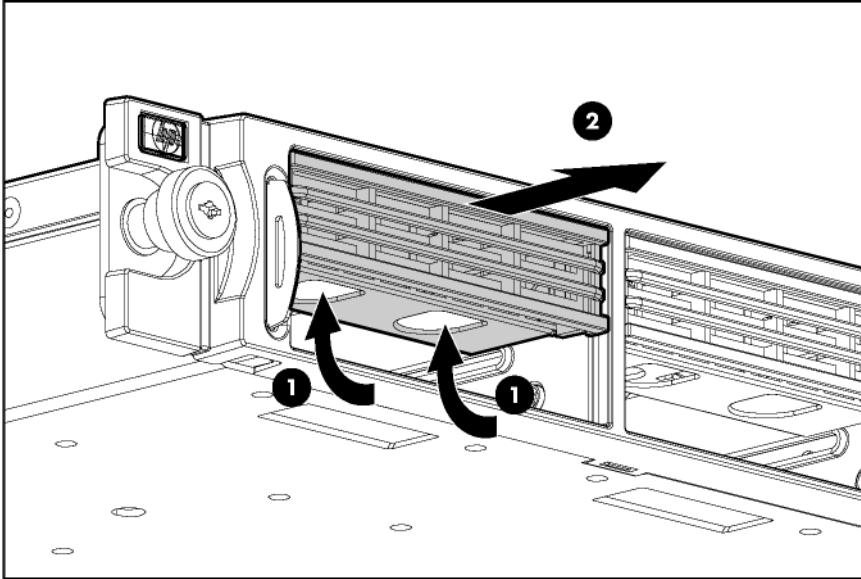

To replace the component, reverse the removal procedure.

Hot-plug power supply

- WARNING:** To reduce the risk of electric shock, do not disassemble the power supply or attempt to repair it. Replace it only with the specified spare part.
- CAUTION:** Do not attempt to remove and replace a power supply as a hot-plug procedure unless both bays are populated with power supplies.
- CAUTION:** To prevent improper cooling and thermal damage, do not operate the server unless all bays are populated with either a component or a blank.

To remove the component:

1. Unfasten the cable management solution to access the power supply bays.
2. Disconnect the power cord.

3. Remove the power supply.

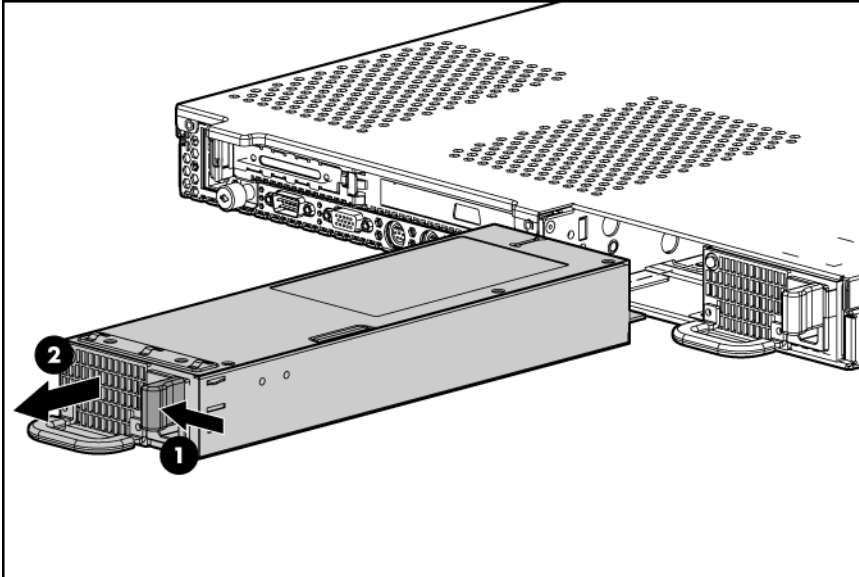

To replace the component, reverse the removal procedure.

Power supply blank

Remove the component as indicated.

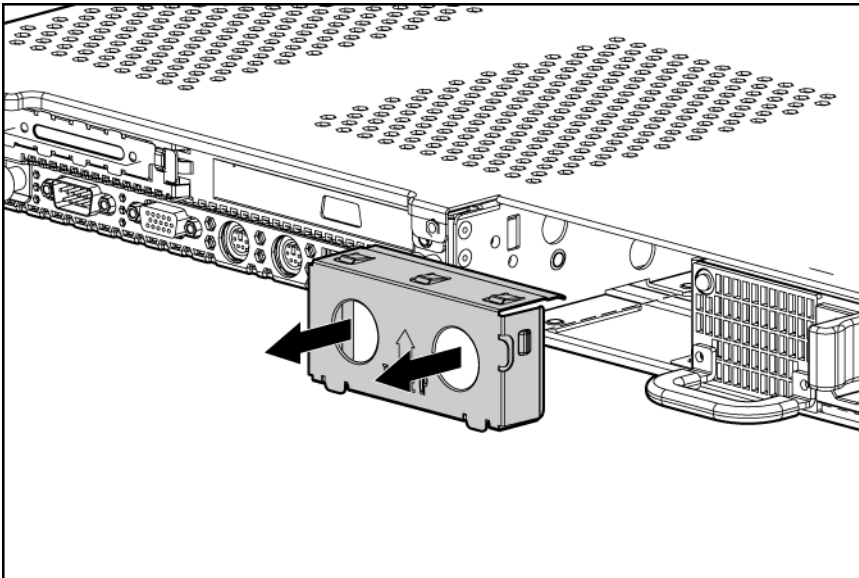

To replace the component, reverse the removal procedure.

Access panel



WARNING: To reduce the risk of personal injury from hot surfaces, allow the drives and the internal system components to cool before touching them.



CAUTION: Do not operate the server for long periods with the access panel open or removed. Operating the server in this manner results in improper airflow and improper cooling that can lead to thermal damage.

To remove the component:

1. Power down the server if the standard cable management solution is installed ("[Power down the server](#)" on page 25).

NOTE: If the optional cable management arm is installed, you can extend the server and perform hot-plug installation or maintenance procedures without powering down the server.

2. Extend or remove the server from the rack ("[Extend the server from the rack](#)" on page 25, "[Remove the server from the rack](#)" on page 26).
3. Lift up on the hood latch handle and remove the access panel.

To replace the component, reverse the removal procedure.

Air baffle

To remove the component:

1. Power down the server (on page 25).
2. Extend or remove the server from the rack ("[Extend the server from the rack](#)" on page 25, "[Remove the server from the rack](#)" on page 26).
3. Remove the access panel ("[Access panel](#)" on page 30).
4. Remove the air baffle.

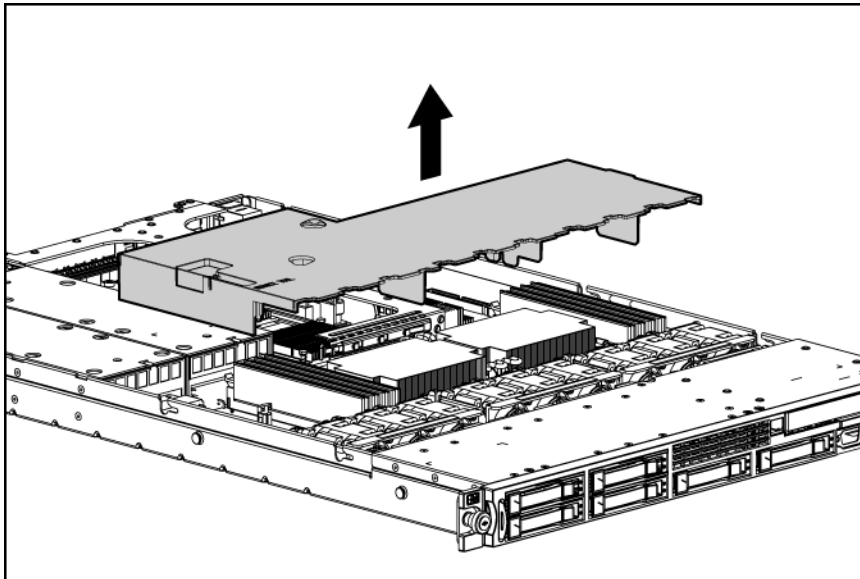

To install the component, reverse the removal procedure.

Fan module

The server has three fan modules.

To remove the component:

1. Power down the server (on page 25).
2. Extend or remove the server from the rack ("Extend the server from the rack" on page 25, "Remove the server from the rack" on page 26).
3. Remove the access panel ("Access panel" on page 30).
4. Remove the air baffle ("Air baffle" on page 31).
5. Remove the fan module.

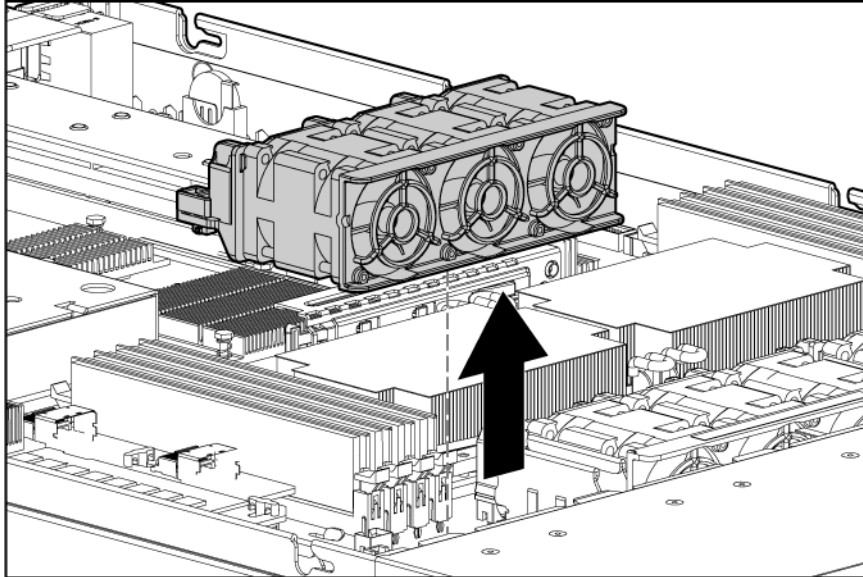

To replace the component, reverse the removal procedure.



IMPORTANT: After installing the fan module, firmly press the top of the module connectors to ensure the connectors are seated properly.

Battery tray

To remove the component:

1. Power down the server (on page 25).
2. Extend or remove the server from the rack ("Extend the server from the rack" on page 25, "Remove the server from the rack" on page 26).
3. Remove the access panel ("Access panel" on page 30).
4. Remove the air baffle ("Air baffle" on page 31).
5. Remove fan module 2 ("Fan module" on page 31).
6. Remove the battery tray.

- HP Smart Array E200i battery tray

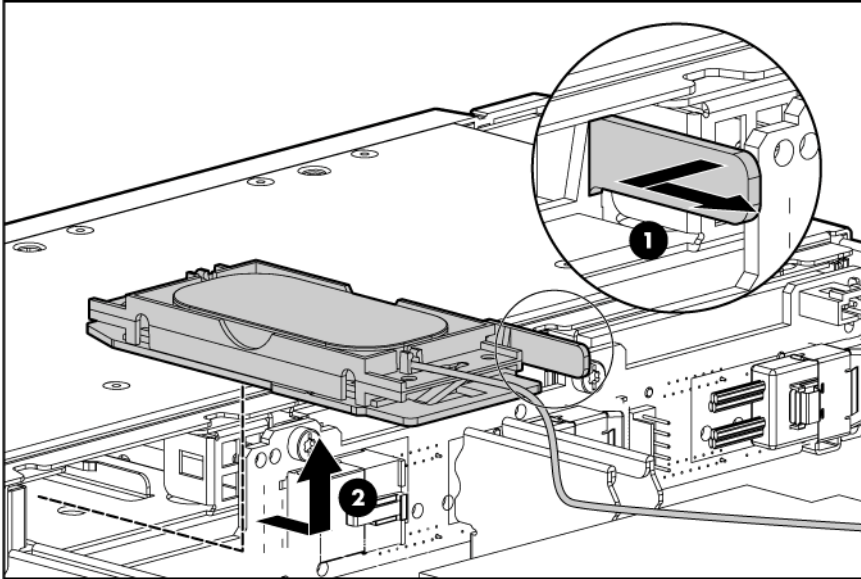

- HP Smart Array P400i battery tray

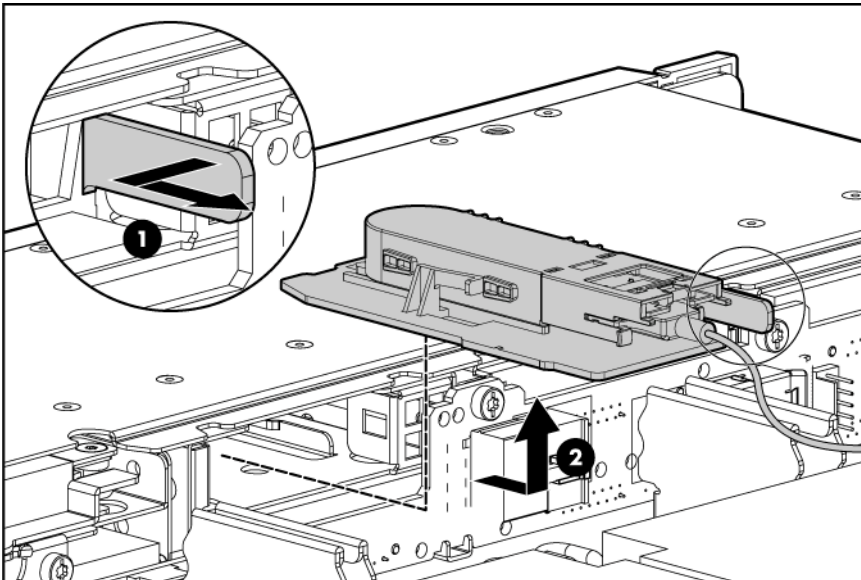

To replace the component, reverse the removal procedure.

Battery pack



CAUTION: To prevent a server malfunction or damage to the equipment, do not add or remove the battery pack while an array capacity expansion, RAID level migration, or stripe size migration is in progress.

To remove the component:

1. Power down the server (on page 25).
2. Extend or remove the server from the rack ("Extend the server from the rack" on page 25, "Remove the server from the rack" on page 26).

3. Remove the access panel ("Access panel" on page 30).
4. Remove the air baffle ("Air baffle" on page 31).
5. Remove fan module 2 ("Fan module" on page 31).
6. Remove the battery tray ("Battery tray" on page 32).
7. Remove the battery pack.
 - HP Smart Array E200i battery pack

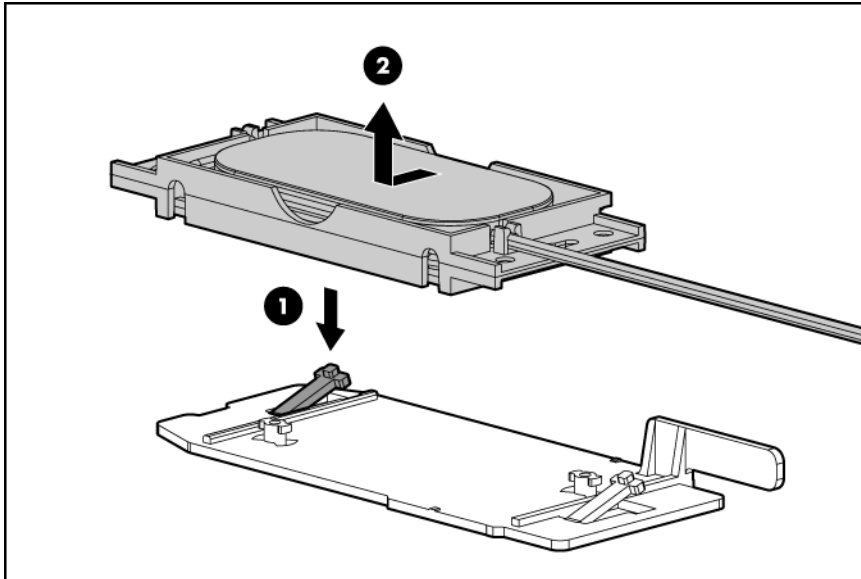

- HP Smart Array P400i battery pack

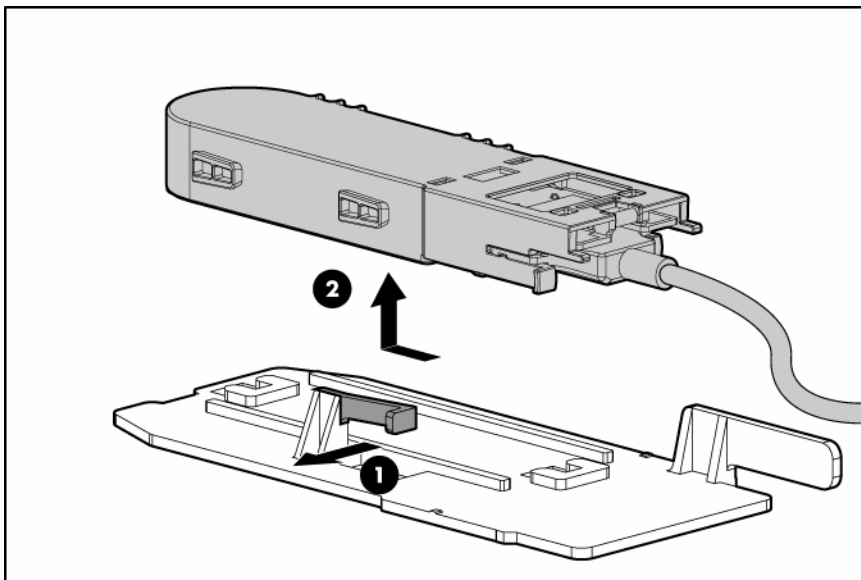

To replace the component, reverse the removal procedure.

Multibay blank or device

To remove the component:

1. Power down the server (on page 25).

NOTE: Access to the ejector button is intentionally restricted. To eject the optical device, push the ejector button with a small flat object such as a key or pen.

2. Eject the device or blank.



CAUTION: To prevent improper cooling and thermal damage, do not operate the server unless all bays are populated with either a component or a blank.

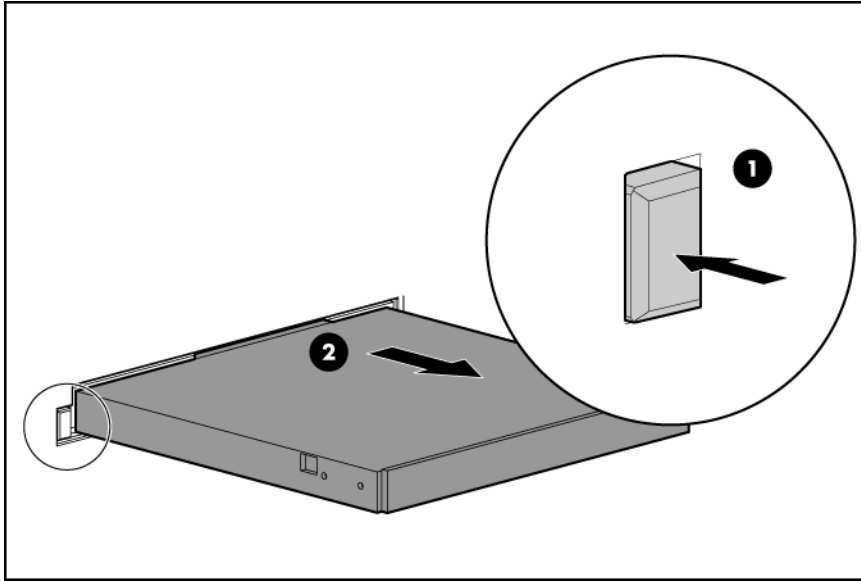

To replace the component, reverse the removal procedure.

Multibay backplane assembly

To remove the component:

1. Power down the server (on page 25).
2. Extend or remove the server from the rack ("[Extend the server from the rack](#)" on page 25, "[Remove the server from the rack](#)" on page 26).
3. Remove the access panel ("[Access panel](#)" on page 30).
4. Remove the air baffle ("[Air baffle](#)" on page 31).
5. Remove fan module 3 ("[Fan module](#)" on page 31).
6. Disconnect the cable from the multibay backplane.
7. Remove any device in the multibay ("[Multibay blank or device](#)" on page 34).
8. Remove the two T-15 Torx multibay backplane assembly screws.

9. Remove the multibay backplane assembly.

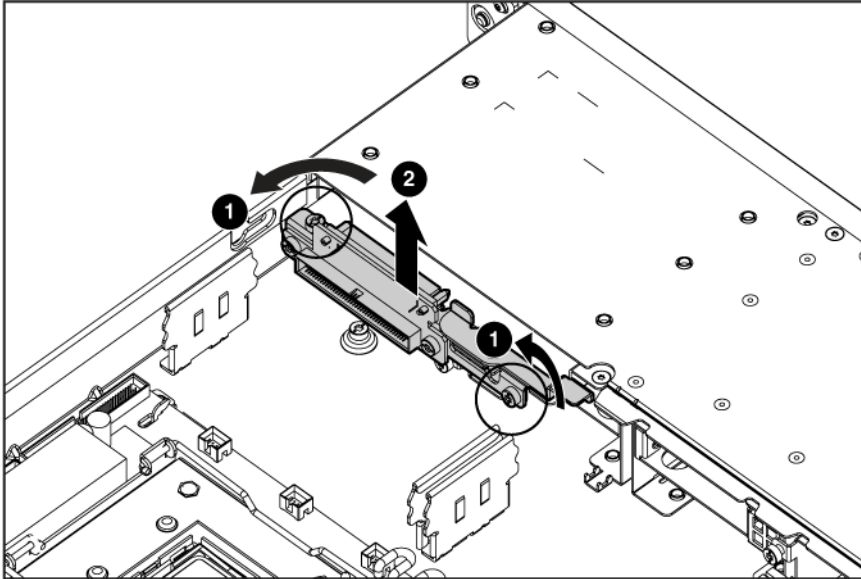

10. Remove the multibay backplane board from the assembly.

To replace the component, reverse the removal procedure.

SAS backplane

To remove the component:

1. Power down the server (on page 25).
2. Extend or remove the server from the rack ("[Extend the server from the rack](#)" on page 25, "[Remove the server from the rack](#)" on page 26).
3. Remove the access panel ("[Access panel](#)" on page 30).
4. Remove all SAS or SATA hard drives ("[Hot-plug SAS or SATA hard drives](#)" on page 27).
5. Remove any device in the multibay ("[Multibay blank or device](#)" on page 34).
6. Remove the air baffle ("[Air baffle](#)" on page 31).
7. Remove all fan modules ("[Fan module](#)" on page 31).
8. Remove the integrated array controller battery tray ("[Battery tray](#)" on page 32) (with battery and cable, if applicable.)
9. Remove the multibay backplane assembly ("[Multibay backplane assembly](#)" on page 35).

10. Disconnect the power and data cables from the SAS backplane.

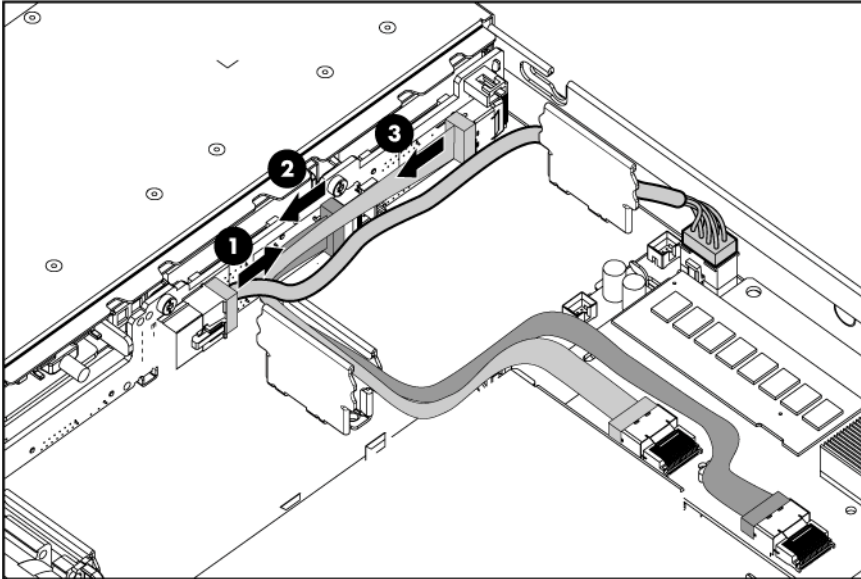

11. Remove the three T-15 Torx screws from the backplane.
12. Remove the backplane.

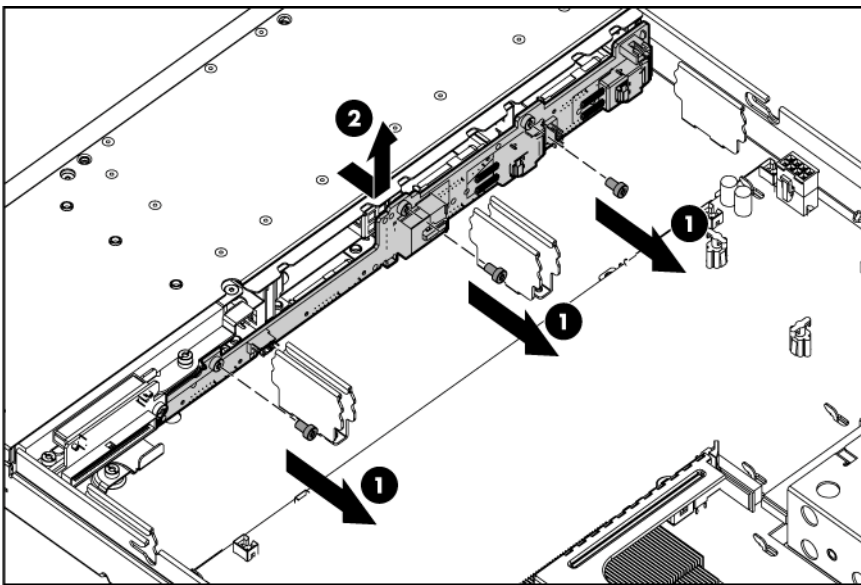

To replace the component, reverse the removal procedure.

Systems Insight Display

The Systems Insight Display is an assembly that includes the front panel LEDs, Power On/Standby button, and a cable.

To remove the component:

1. Power down the server (on page 25).
2. Extend or remove the server from the rack ("[Extend the server from the rack](#)" on page 25, "[Remove the server from the rack](#)" on page 26).
3. Remove the access panel ("[Access panel](#)" on page 30).

4. Remove the front bezel ("Front bezel" on page 27).
5. Remove the air baffle ("Air baffle" on page 31).
6. Remove fan module 3 ("Fan module" on page 31).
7. Remove the multibay backplane assembly ("Multibay backplane assembly" on page 35).
8. Disconnect the Systems Insight Display cable.
9. Remove the T-15 Torx screw that secures the Systems Insight Display.

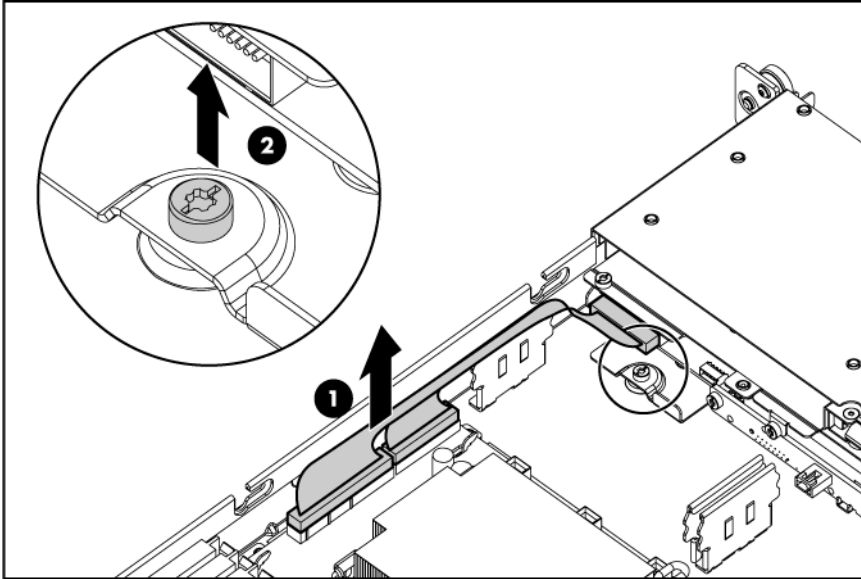

10. Remove the Systems Insight Display.

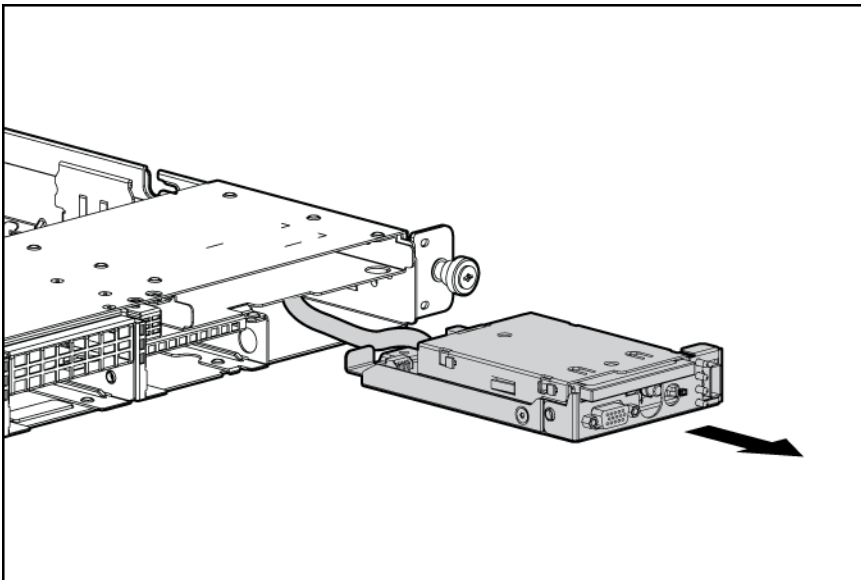

To replace the component, reverse the removal procedure.

PCI riser board assembly

To remove the component:



CAUTION: To prevent damage to the server or expansion boards, power down the server and remove all AC power cords before removing or installing the PCI riser board assembly.

1. Power down the server (on page 25).
2. Extend or remove the server from the rack ("Extend the server from the rack" on page 25, "Remove the server from the rack" on page 26).
3. Remove the access panel ("Access panel" on page 30).
4. Remove the air baffle ("Air baffle" on page 31).
5. Remove the PCI riser board assembly:
 - a. Disconnect any external cables connected to any existing expansion boards.
 - b. Loosen the four PCI riser board assembly thumbscrews.
 - c. Lift the assembly to unseat the PCI riser boards and remove the assembly.

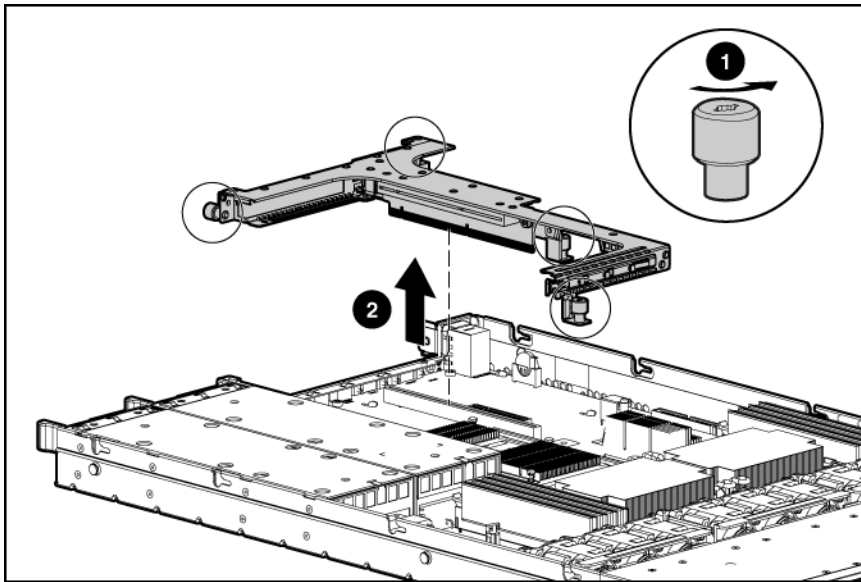

To replace the component, reverse the removal procedure.

PCI-X or PCI Express expansion board

To remove the component:

1. Power down the server (on page 25).
2. Extend the server from the rack, if applicable ("Extend the server from the rack" on page 25).
3. Remove the access panel ("Access panel" on page 30).
4. Remove the air baffle ("Air baffle" on page 31).
5. Remove the PCI riser board assembly ("PCI riser board assembly" on page 38).

6. Remove any expansion board installed in the assembly.

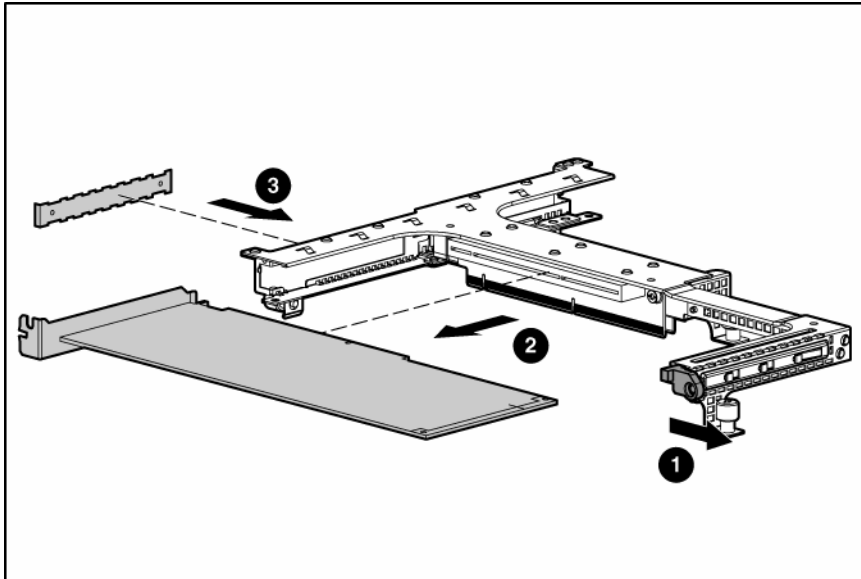

To replace the component, reverse the removal procedure.



CAUTION: To prevent improper cooling and thermal damage, do not operate the server unless all PCI slots have either an expansion slot cover or an expansion board installed.

PCI Express riser board

To remove the component:

1. Power down the server (on page 25).
2. Extend the server from the rack, if applicable ("[Extend the server from the rack](#)" on page 25).
3. Remove the access panel ("[Access panel](#)" on page 30).
4. Remove the air baffle ("[Air baffle](#)" on page 31).
5. Remove the PCI riser board assembly ("[PCI riser board assembly](#)" on page 38).
6. Remove all expansion boards. ("[PCI-X or PCI Express expansion board](#)" on page 39)
7. Remove the two screws securing the riser board to the riser board assembly.

8. Remove the full-length PCI Express riser board from the riser board assembly.

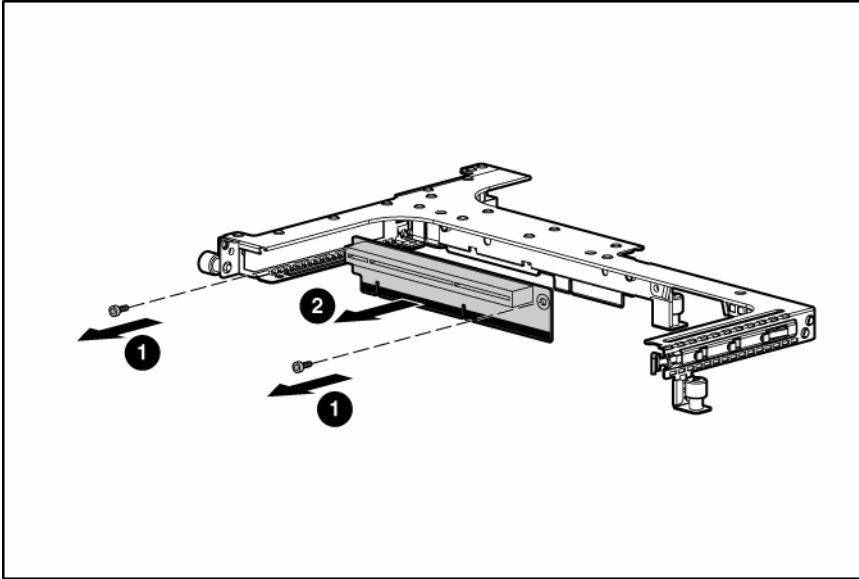

To replace the component, reverse the removal procedure.

Integrated HP Smart Array E200i Controller or HP Smart Array P400i Controller

To remove the component:

1. Power down the server (on page [25](#)).
2. Extend the server from the rack (on page [25](#)).
3. Remove the access panel ("[Access panel](#)" on page [30](#)).
4. Remove the air baffle ("[Air baffle](#)" on page [31](#)).
5. Disconnect all cables from the integrated array controller.

6. Disconnect the backplane power cable from the system board.

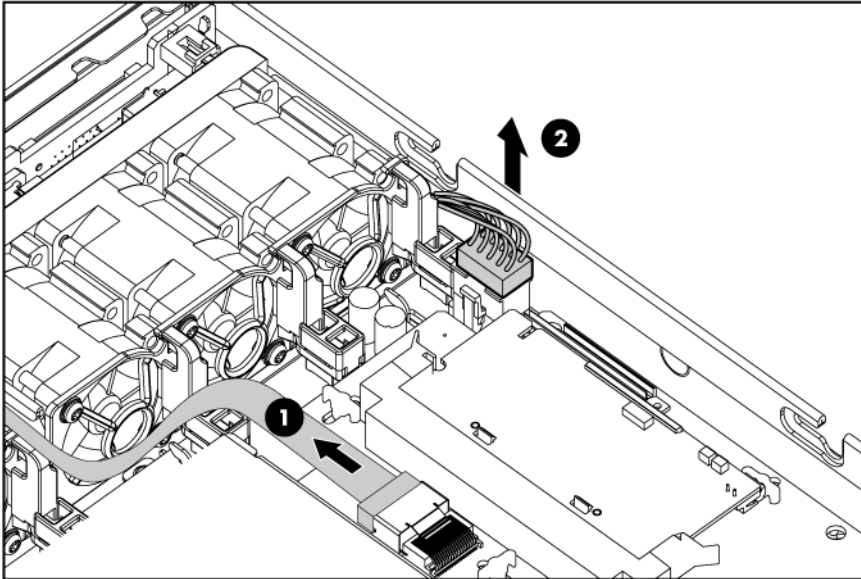

7. Turn the quarter-turn fasteners and lift the integrated array controller away from the system board.

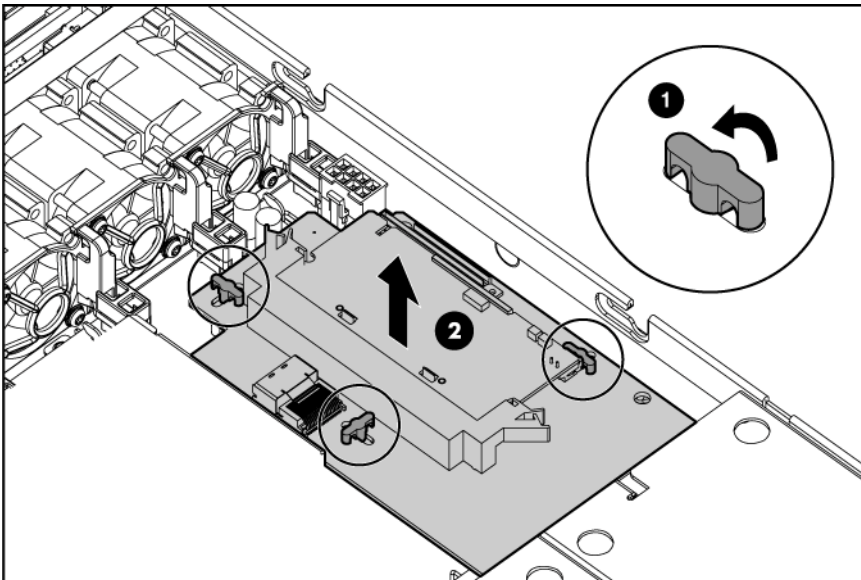

To replace the component, reverse the removal procedure.

DIMMs

To remove the component:

1. Power down the server (on page 25).
2. Extend the server from the rack (on page 25).
3. Remove the access panel ("Access panel" on page 30).
4. Remove the air baffle ("Air baffle" on page 31).
5. Open the DIMM slot latches.

6. Remove the DIMM.

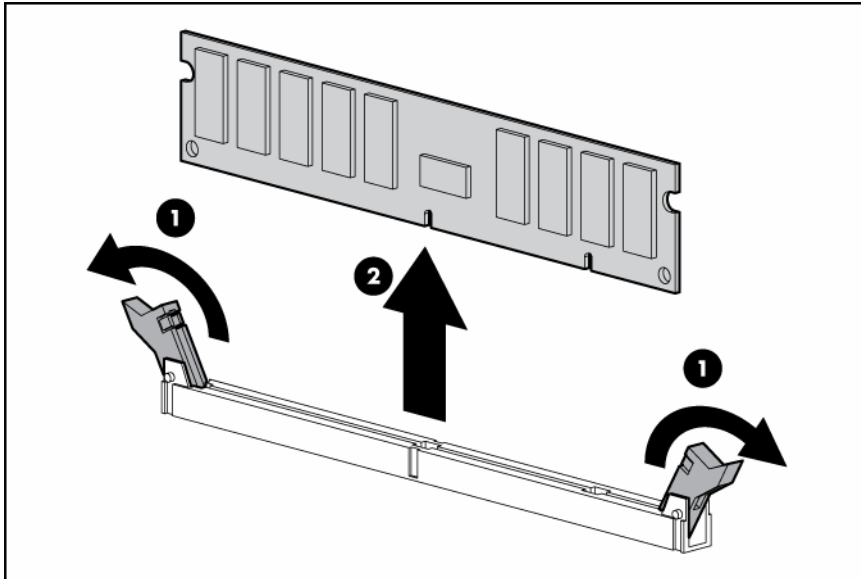

To replace the component, reverse the removal procedure.

Heatsink

To remove the component:

1. Power down the server (on page 25).
2. Extend the server from the rack (on page 25).
3. Remove the access panel ("Access panel" on page 30).
4. Remove the air baffle ("Air baffle" on page 31).
5. Open the heatsink retaining latches.
6. Remove the heatsink.

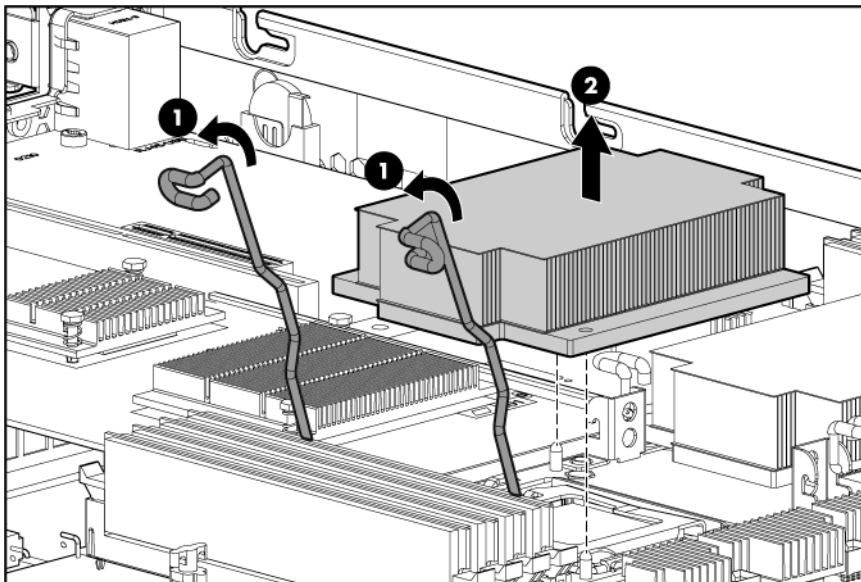

To replace the heatsink:

1. Use the alcohol swab to remove all the existing thermal grease from the processor. Allow the alcohol to evaporate before continuing.
2. Apply new grease to the top of the processor in one of the following patterns to ensure even distribution.

 **CAUTION:** The heatsink thermal interface media is not reusable and must be replaced if the heatsink is removed from the processor after it has been installed.

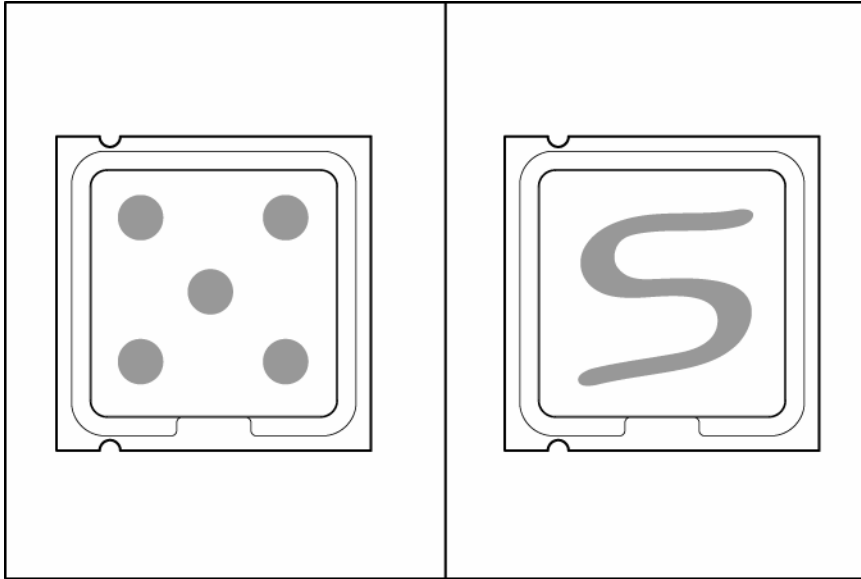

3. Install the heatsink.

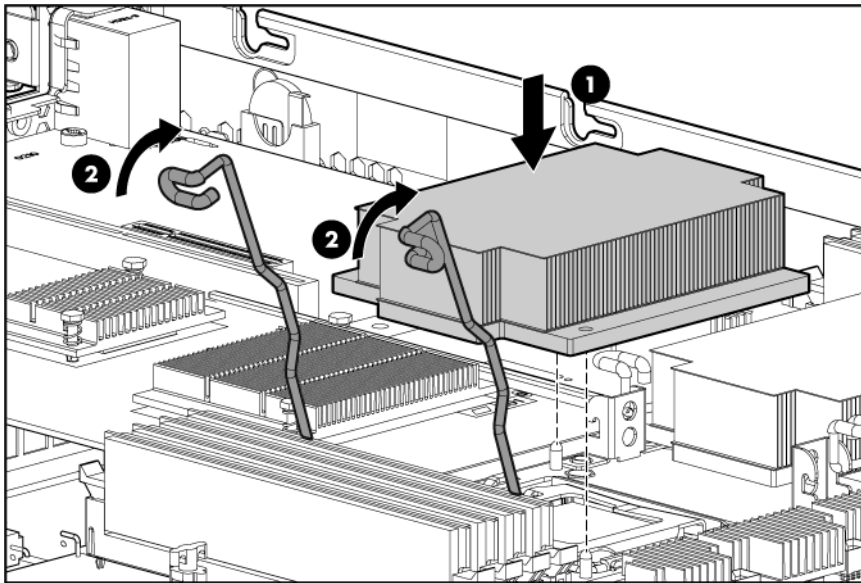









4. Install the air baffle ("[Air baffle](#)" on page 31).
5. Install the access panel ("[Access panel](#)" on page 30).

Processor

The server supports single- and dual-processor operation. With two processors installed, the server supports boot functions through the processor installed in processor socket 1.

The server uses embedded PPMs as DC-to-DC converters to provide the proper power to each processor.

-
-  **WARNING:** To reduce the risk of personal injury from hot surfaces, allow the drives and the internal system components to cool before touching them.
-
-  **CAUTION:** To avoid damage to the processor and system board, only authorized personnel should attempt to replace or install the processor in this server.
-
-  **CAUTION:** To prevent possible server malfunction, do not mix processors of different speeds or cache sizes. Refer to the label on the processor heatsink for a description of the processor.
-
-  **CAUTION:** To avoid damage to the system board:
- Do not touch the processor socket contacts.
 - Always install the processor socket cover after removing the processor from the socket.
 - Do not tilt or slide the processor when lowering the processor into the socket.
-
-  **CAUTION:** To avoid damage to the processor:
- Handle the processor only by the edges.
 - Do not touch the bottom of the processor, especially the contact area.
-
-  **CAUTION:** To help avoid damage to the processor and system board, do not install the processor without using the processor installation tool.
-
-  **CAUTION:** Removal of the processor or heatsink renders the thermal layer between the processor and heatsink useless. A new heatsink must be ordered and installed before reinstalling the processor.
-
-  **IMPORTANT:** Processor socket 1 must be populated at all times or the server does not function.
-

To remove a processor:

1. Power down the server (on page 25).
2. Extend or remove the server from the rack ("[Extend the server from the rack](#)" on page 25, "[Remove the server from the rack](#)" on page 26).
3. Remove the access panel ("[Access panel](#)" on page 30).
4. Remove the air baffle ("[Air baffle](#)" on page 31).
5. Open the heatsink retaining latches.

6. Remove the heatsink.

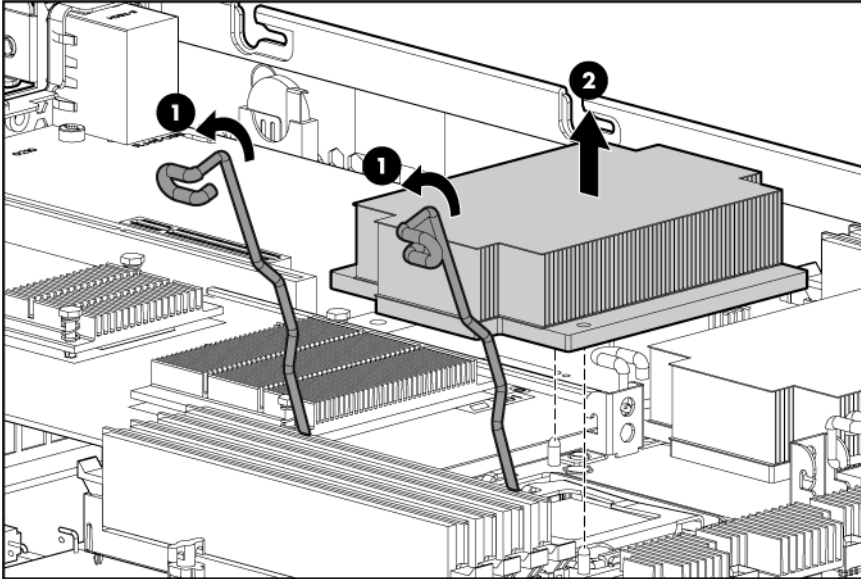

7. Open the processor retaining latch and the processor socket retaining bracket.

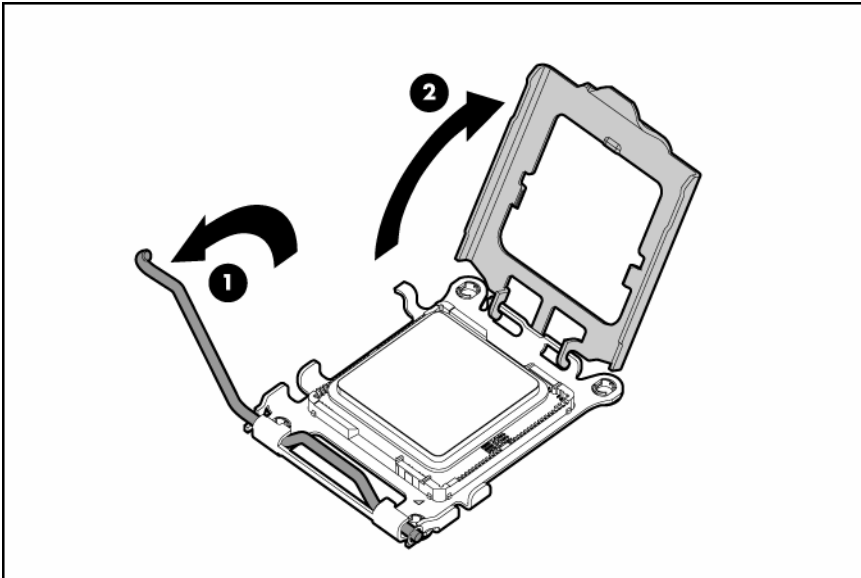

8. Using your fingers, remove the failed processor.

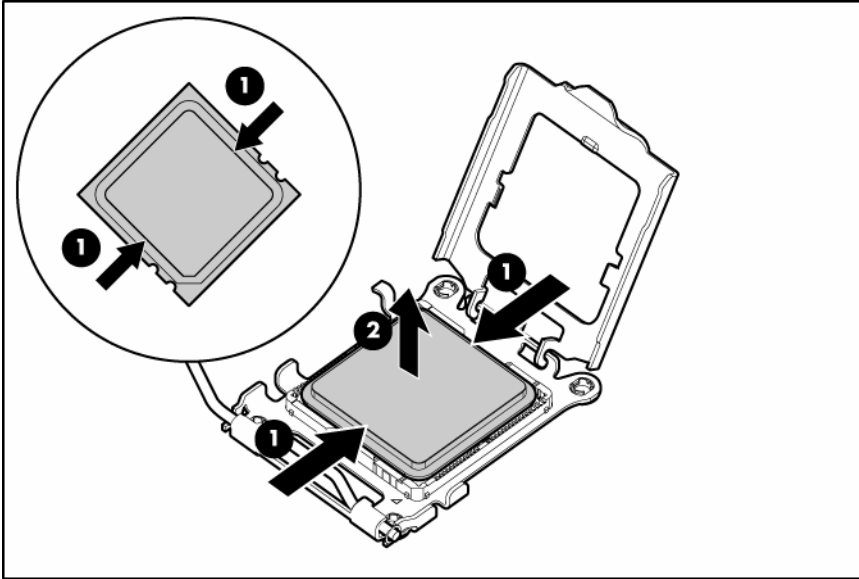

IMPORTANT: Be sure the replacement processor remains inside the processor installation tool.

9. If the processor has separated from the installation tool, carefully re-insert the processor in the tool.

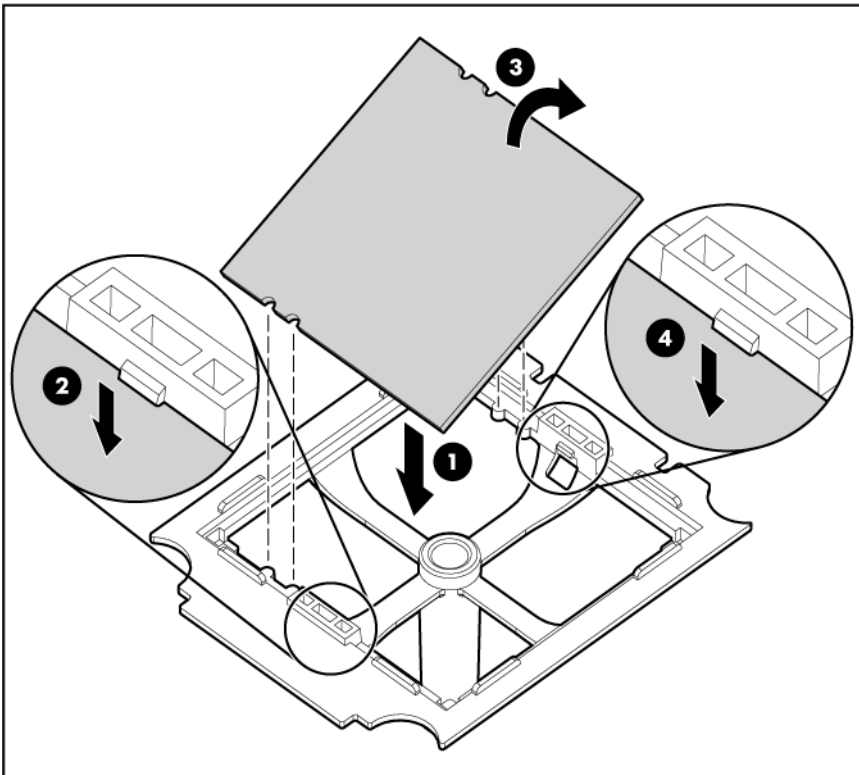

10. Align the processor installation tool with the socket and install the spare processor.



CAUTION: The processor is designed to fit one way into the socket. Use the alignment guides on the processor and socket to properly align the processor with the socket.

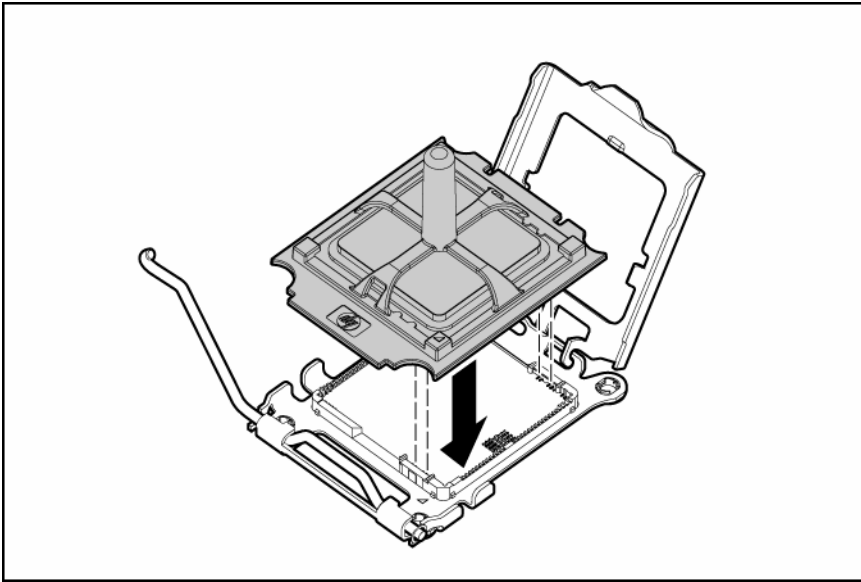

11. Press down firmly until the processor installation tool clicks and separates from the processor, and then remove the processor installation tool.

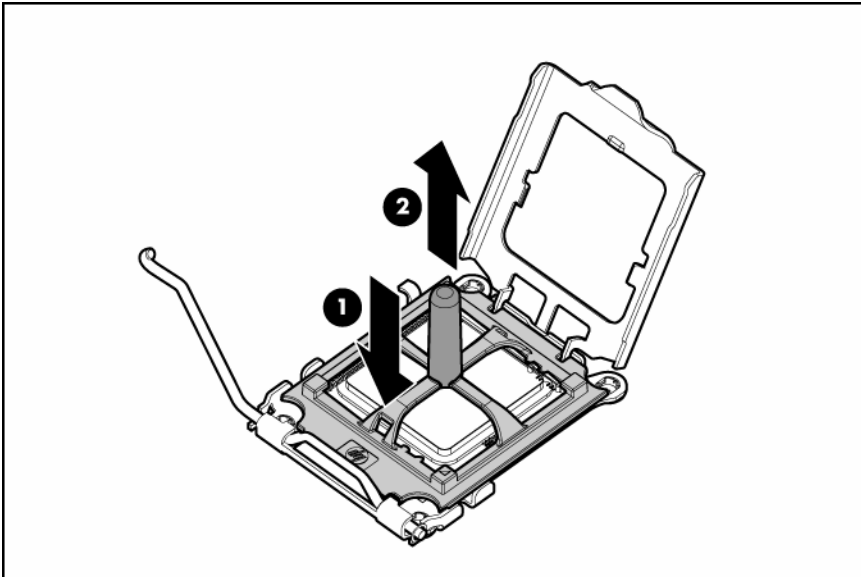

12. Close the processor retaining latch and the processor socket retaining bracket.

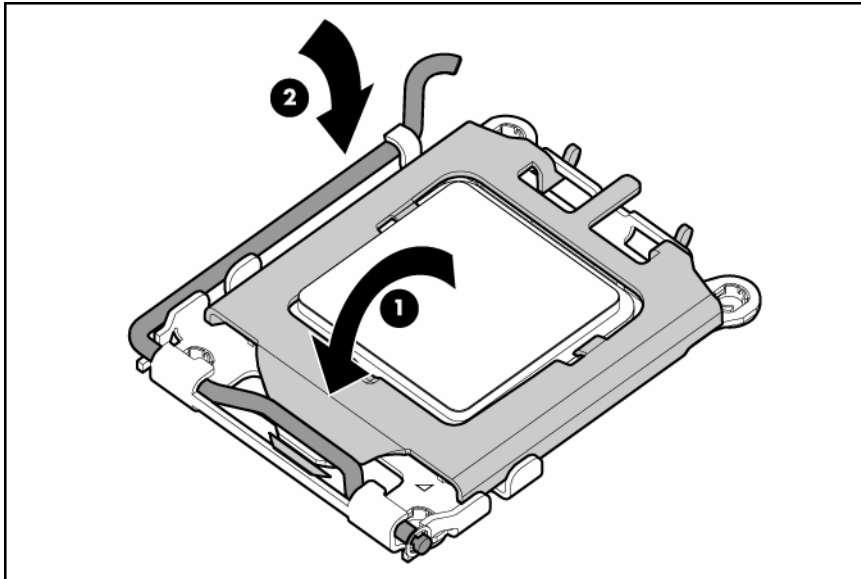

13. Clean the old thermal grease from the heatsink with the alcohol swab. Allow the alcohol to evaporate before continuing.
14. Apply all the grease to the top of the processor in one of the following patterns to ensure even distribution.

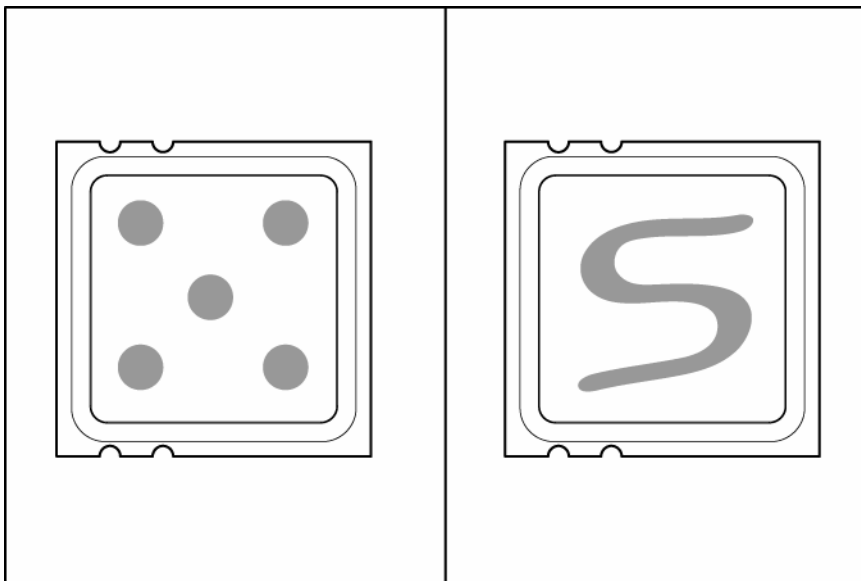

15. Install the heatsink.

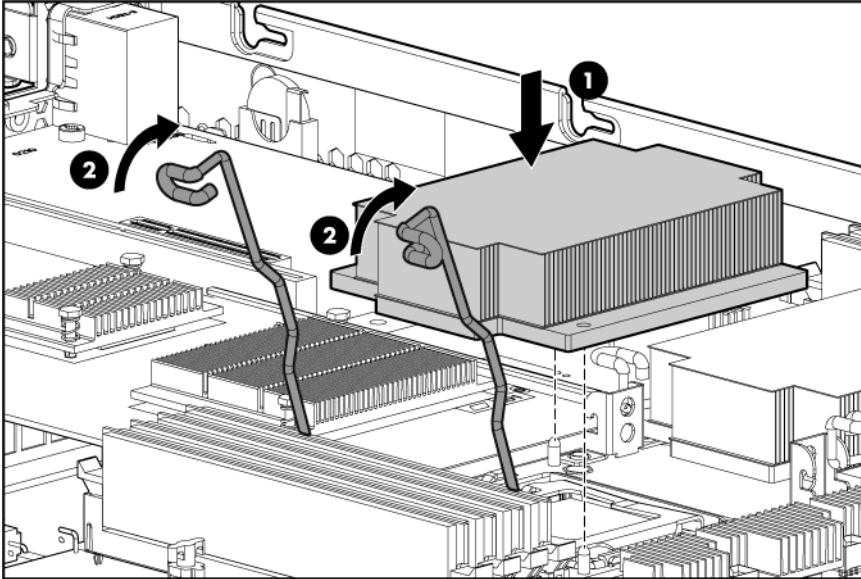

16. Install the air baffle ("Air baffle" on page 31).
17. Install the access panel ("Access panel" on page 30).
18. Slide the server into the rack.
19. Power up the server.

System battery

If the server no longer automatically displays the correct date and time, you may need to replace the battery that provides power to the real-time clock. Under normal use, battery life is 5 to 10 years.



WARNING: The computer contains an internal lithium manganese dioxide, a vanadium pentoxide, or an alkaline battery pack. A risk of fire and burns exists if the battery pack is not properly handled. To reduce the risk of personal injury:

- Do not attempt to recharge the battery.
- Do not expose the battery to temperatures higher than 60°C (140°F).
- Do not disassemble, crush, puncture, short external contacts, or dispose of in fire or water.
- Replace only with the spare designated for this product.

To remove the component:

1. Power down the server (on page 25).
2. Extend or remove the server from the rack ("Extend the server from the rack" on page 25, "Remove the server from the rack" on page 26).
3. Remove the access panel ("Access panel" on page 30).
4. Locate the battery on the system board ("System board components" on page 70).

5. Remove the battery.

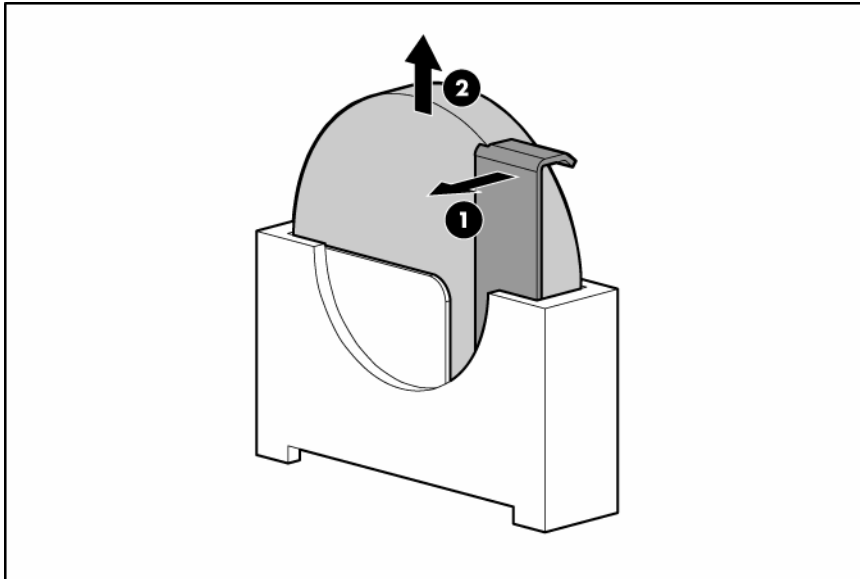

IMPORTANT: Replacing the system board battery resets the system ROM to its default configuration. After replacing the battery, reconfigure the system through RBSU.

To replace the component, reverse the removal procedure.

For more information about battery replacement or proper disposal, contact an authorized reseller or an authorized service provider.

System board



WARNING: To reduce the risk of personal injury from hot surfaces, allow the drives and the internal system components to cool before touching them.



CAUTION: To avoid damage to the processor and system board, only authorized personnel should attempt to replace or install the processor in this server.



CAUTION: To prevent possible server malfunction and damage to the equipment, multiprocessor configurations must contain processors with the same part number.



CAUTION: To avoid damage to the system board:

- Do not touch the processor socket contacts.
- Always install the processor socket cover after removing the processor from the socket.
- Do not tilt or slide the processor when lowering the processor into the socket.



CAUTION: To avoid damage to the processor:

- Handle the processor only by the edges.
- Do not touch the bottom of the processor, especially the contact area.



CAUTION: To help avoid damage to the processor and system board, do not install the processor without using the processor installation tool.



CAUTION: Removal of the processor or heatsink renders the thermal layer between the processor and heatsink useless. A new heatsink must be ordered and installed before reinstalling the processor.



IMPORTANT: Processor socket 1 must be populated at all times or the server does not function.



IMPORTANT: If upgrading processor speed, update the system ROM before installing the processor.

To remove the component:

1. Power down the server (on page [25](#)).
2. Extend or remove the server from the rack ("[Extend the server from the rack](#)" on page [25](#), "[Remove the server from the rack](#)" on page [26](#)).
3. Remove the access panel ("[Access panel](#)" on page [30](#)).
4. Remove all power supplies ("[Hot-plug power supply](#)" on page [29](#)).
5. Remove the air baffle ("[Air baffle](#)" on page [31](#)).
6. Remove the three fan modules. ("[Fan module](#)" on page [31](#))
7. Disconnect all cables connected to the system board ("[System board components](#)" on page [70](#)). For additional information, see "Cabling" ("[Cabling](#)" on page [58](#)).
8. Remove the PCI riser board assembly ("[PCI riser board assembly](#)" on page [38](#)).
9. Remove the integrated array controller ("[Integrated HP Smart Array E200i Controller or HP Smart Array P400i Controller](#)" on page [41](#)).
10. Remove all DIMMs ("[DIMMs](#)" on page [42](#)).
11. Remove the heatsink ("[Heatsink](#)" on page [43](#)).

12. For each installed processor, open the processor retaining latch and the processor socket retaining bracket on the failed system board.

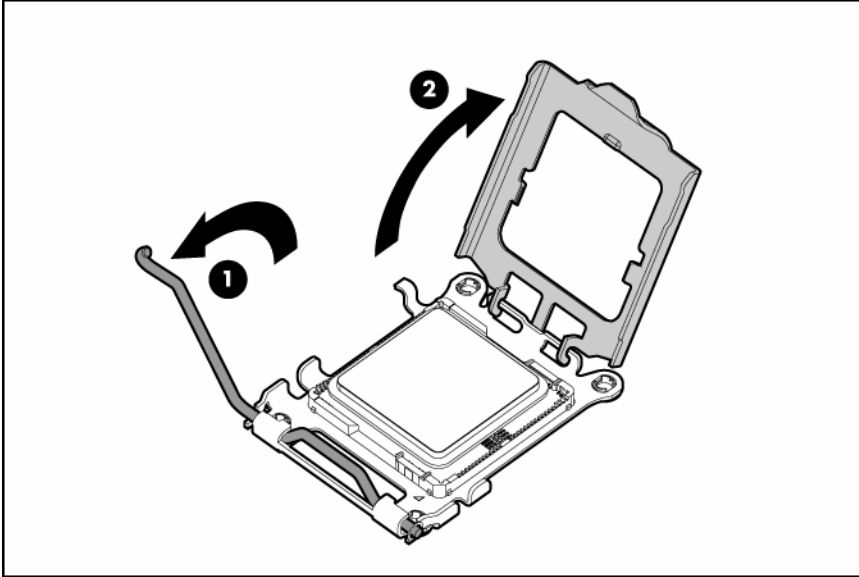

13. For each installed processor, use your fingers to remove the processor from the failed system board.

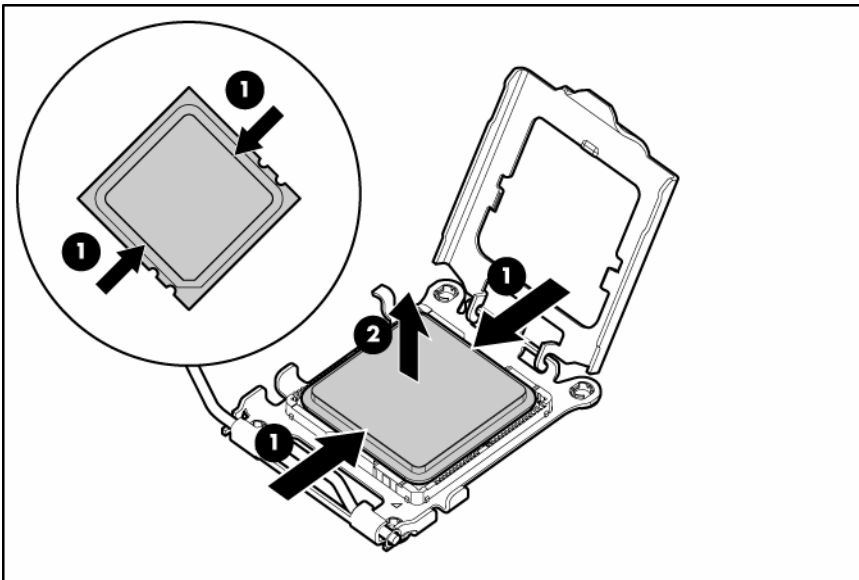

CAUTION: To avoid damage to the system board:

- Do not touch the processor socket contacts.
- Always install the processor socket cover after removing the processor from the socket.
- Do not tilt or slide the processor when lowering the processor into the socket.



CAUTION: To avoid damage to the processor:

- Handle the processor only by the edges.
- Do not touch the bottom of the processor, especially the contact area.

14. Remove the failed system board.

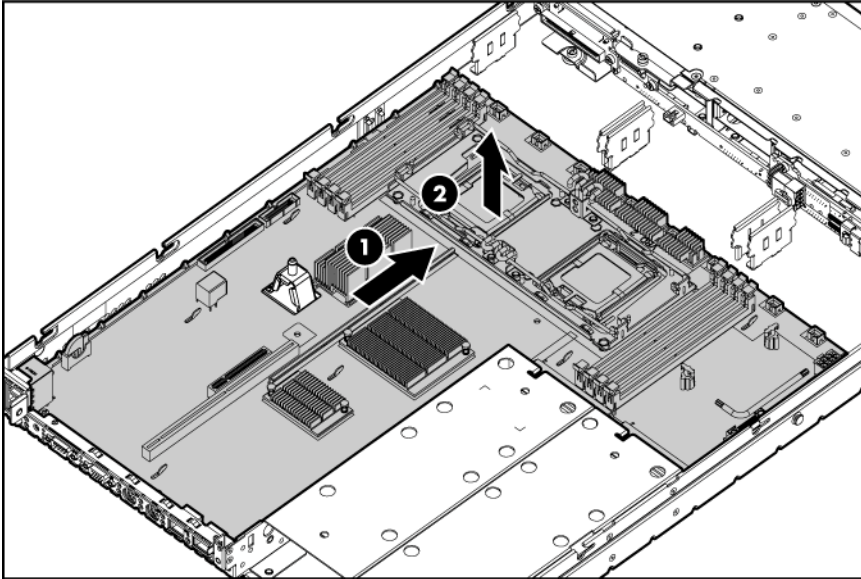

To replace the system board:

1. Install the spare system board in the server before installing the processor.
2. Prepare the processor socket on the spare system board.
 - a. Remove the processor socket protective cover.

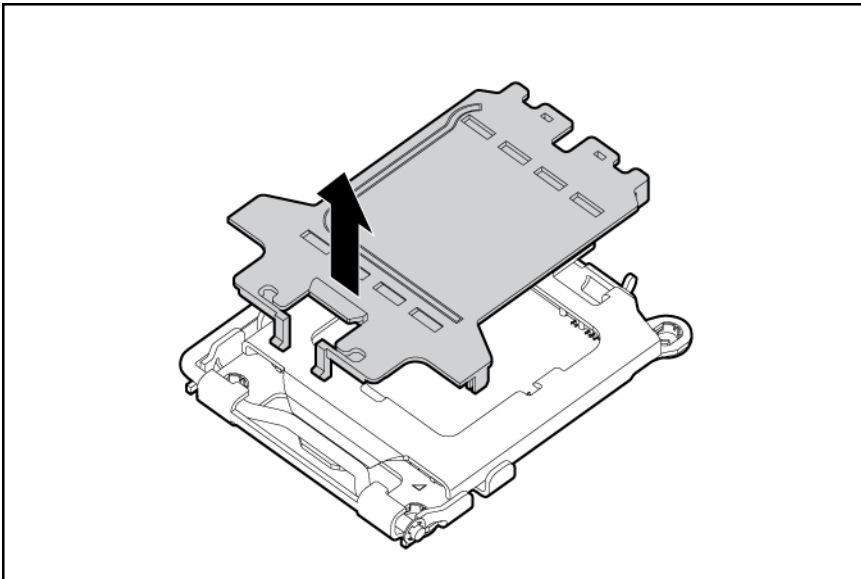

- b. Open the processor retaining latch and the processor socket retaining bracket.

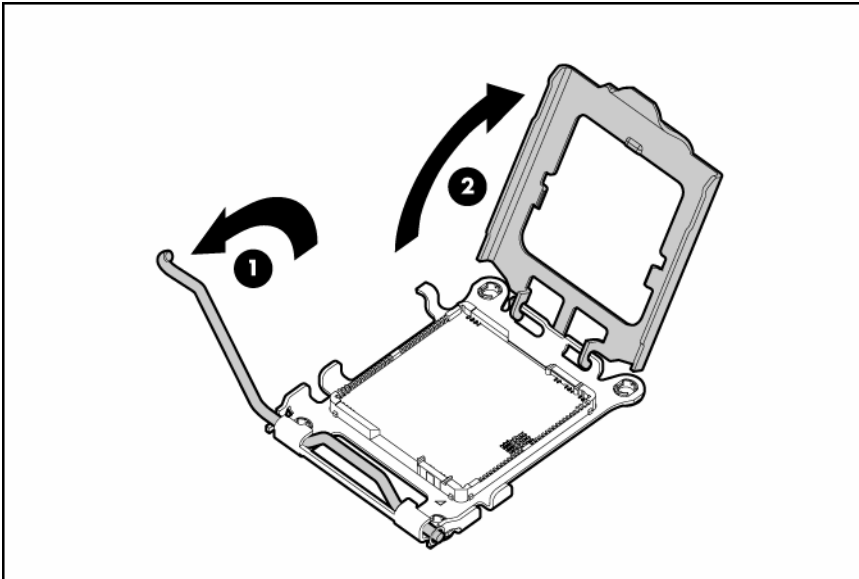

3. Install the processor socket cover onto the processor socket of the failed system board.
4. Install the processor on the spare system board.

△ **CAUTION:** The processor is designed to fit one way into the socket. Use the alignment guides on the processor and socket to properly align the processor with the socket. Refer to the server hood label for specific instructions.

△ **CAUTION:** Always install the processor parallel to the system board to avoid damage to the pins.

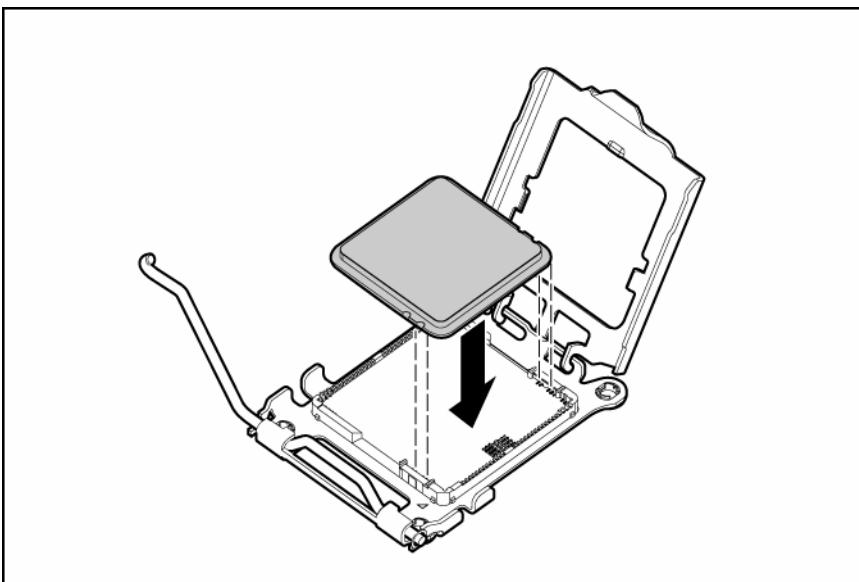

5. Close the processor retaining latch and the processor socket retaining bracket.

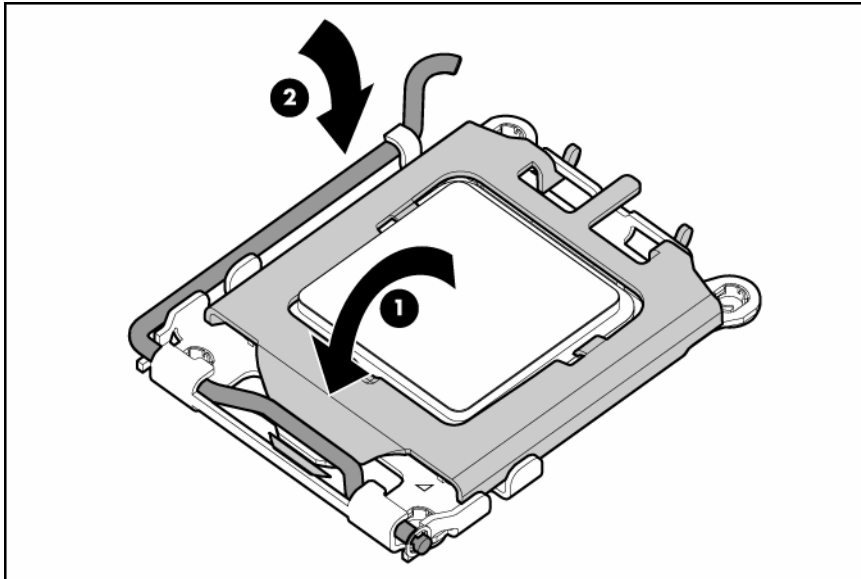

6. Clean the old thermal grease from the processor and heatsink with the alcohol swab. Allow the alcohol to evaporate before continuing.
7. Apply grease to the top of the processor in one of the following patterns to ensure even distribution.



CAUTION: The heatsink thermal interface media is not reusable and must be replaced if the heatsink is removed from the processor after it has been installed.

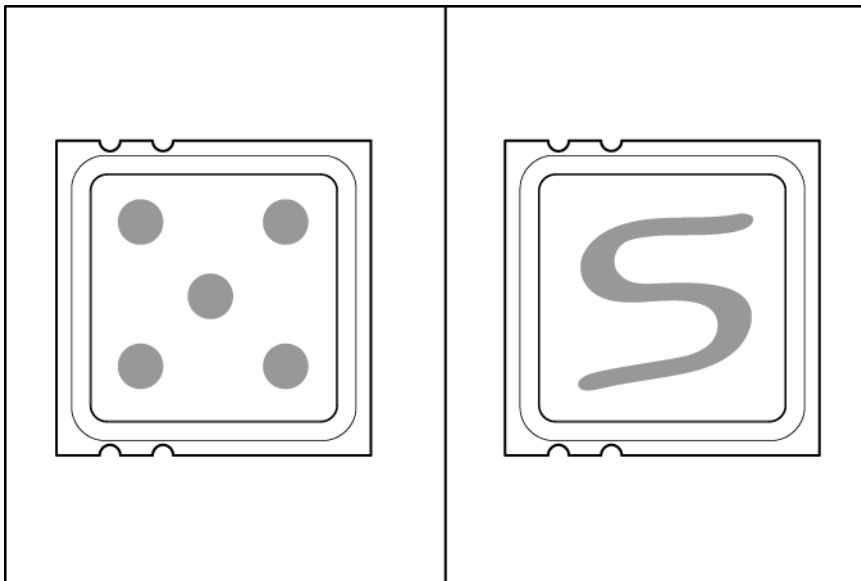

8. Install the heatsink ("Heatsink" on page 43).



IMPORTANT: To ensure proper cooling, be sure the correct processor air baffle (on page 31) is installed at all times.

9. Install all components removed from the failed system board.



IMPORTANT: Install all components with the same configuration that was used on the failed system board.

10. Install all power supplies ("[Hot-plug power supply](#)" on page 29).
11. Install the access panel ("[Access panel](#)" on page 30).
12. Power up the server.

After you replace the system board, you must re-enter the server serial number and the product ID.

1. During the server startup sequence, press the **F9** key to access RBSU.
2. Select the **Advanced Options** menu.
3. Select **Serial Number**. The following warning is displayed:
Warning: The serial number should ONLY be modified by qualified service personnel. This value should always match the serial number located on the chassis.
4. Press the **Enter** key to clear the warning.
5. Enter the serial number.
6. Select **Product ID**. The following warning is displayed.
Warning: The Product ID should ONLY be modified by qualified service personnel. This value should always match the Product ID located on the chassis.
7. Enter the product ID and press the **Enter** key.
8. Press the **Esc** key to close the menu.
9. Press the **Esc** key to exit RBSU.
10. Press the **F10** key to confirm exiting RBSU. The server will automatically reboot.

Cabling

Cabling overview

This section provides guidelines that help you make informed decisions about cabling the server and hardware options to optimize performance.

For information on cabling peripheral components, refer to the white paper on high-density deployment at the HP website (<http://www.hp.com/products/servers/platforms>).

 **CAUTION:** When routing cables, always be sure that the cables are not in a position where they can be pinched or crimped.

Array controller cabling

Depending on the primary controller installed, various cabling configurations exist:

- HP Smart Array E200i Controller cabling (on page 58)
- HP Smart Array P400i Controller cabling (on page 59)
- PCI Smart Array controller cabling (on page 59)
- Battery pack cabling (on page 60)

HP Smart Array E200i Controller cabling

 **CAUTION:** When routing cables, use the cable trough between fan modules 1 and 2. Be sure the cables do not interfere with fan module installation. Be sure to route the cables around the DIMM connectors so as not to interfere with DIMM installation.

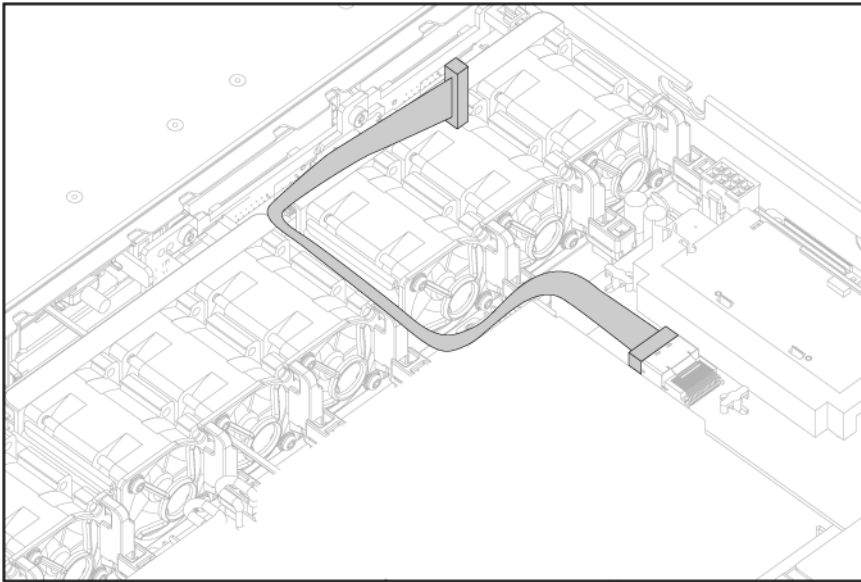

HP Smart Array P400i Controller cabling

- CAUTION:** When routing cables, use the cable trough between fan modules 1 and 2. Be sure the cables do not interfere with fan module installation. Be sure to route the cables around the DIMM connectors so as not to interfere with DIMM installation.

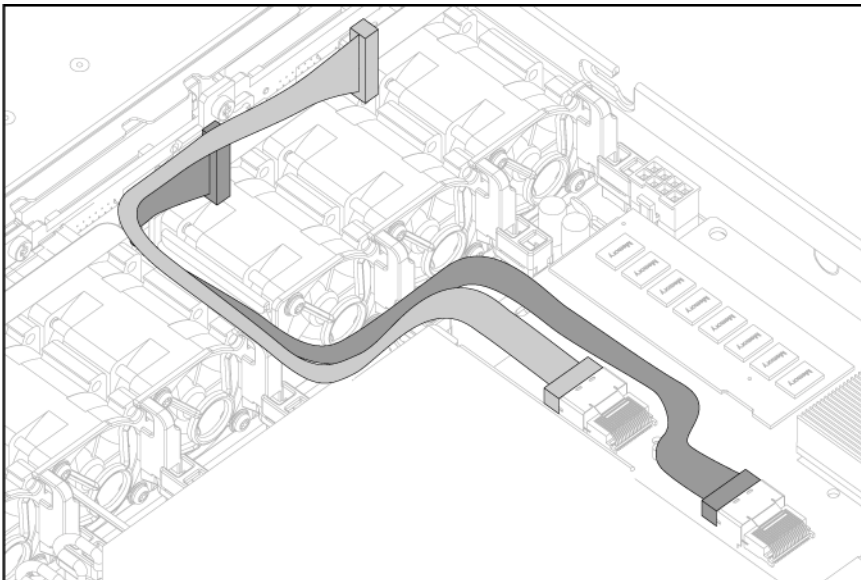

PCI Smart Array controller cabling

- CAUTION:** When routing cables, use the cable trough between fan modules 1 and 2. Be sure the cables do not interfere with fan module installation. Be sure to route the cables around the DIMM connectors so as not to interfere with DIMM installation.

- IMPORTANT:** When using a PCI array controller, be sure to remove the integrated array controller.

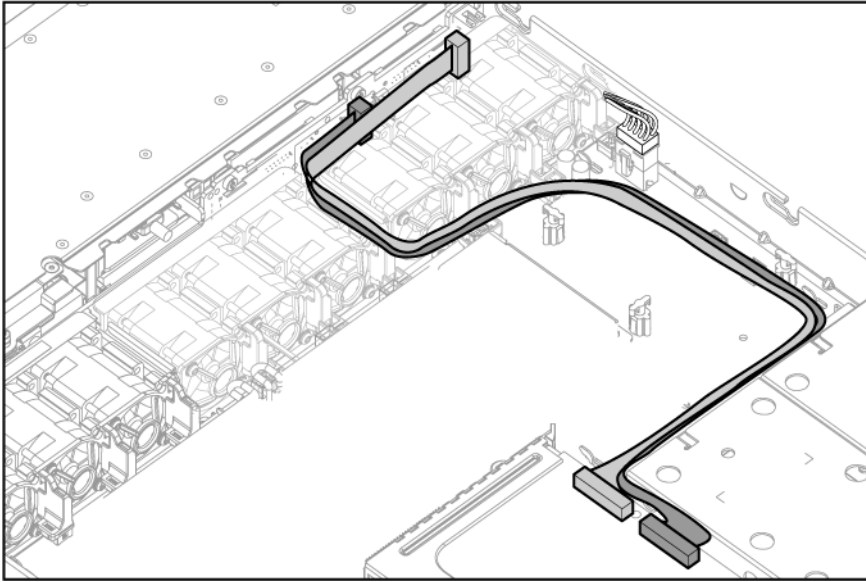

Battery pack cabling

- HP Smart Array E200i Controller battery pack cabling

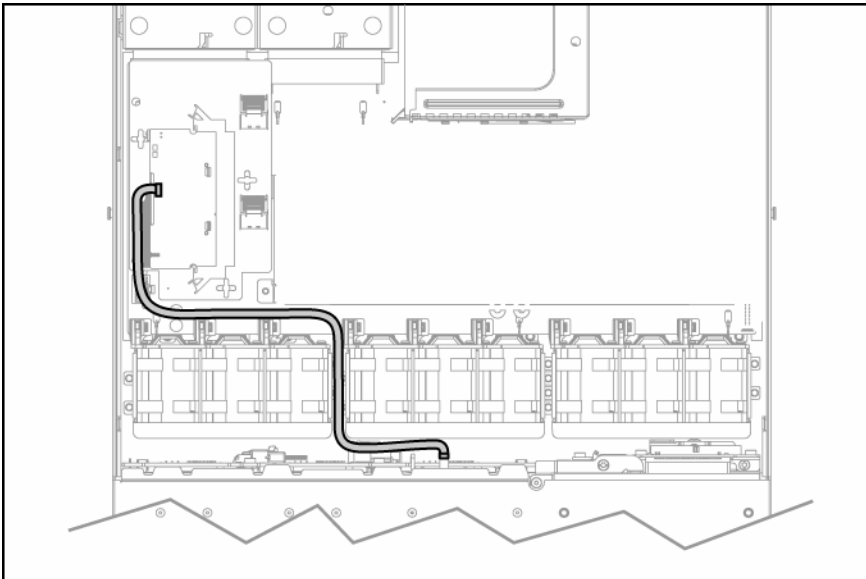

- HP Smart Array P400i Controller battery pack cabling

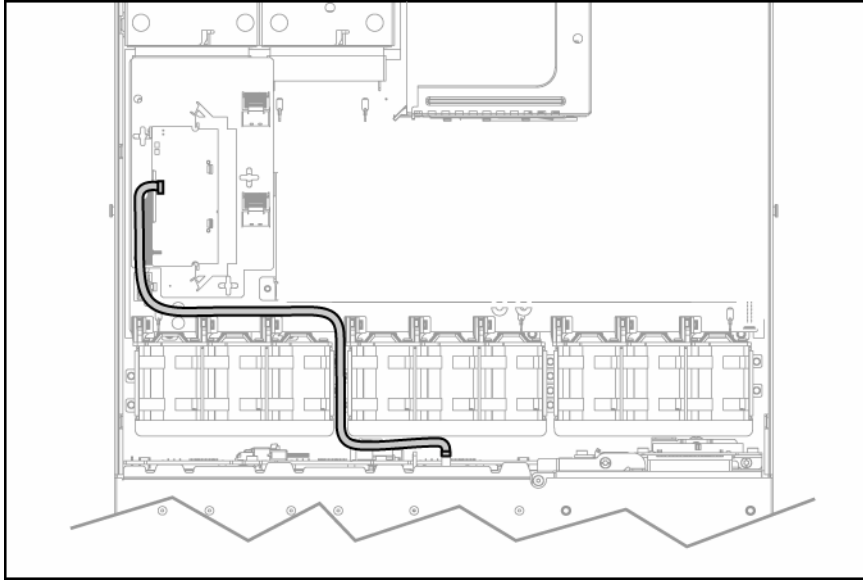

Diagnostic tools

Troubleshooting resources

The *HP ProLiant Servers Troubleshooting Guide* provides procedures for resolving common problems and comprehensive courses of action for fault isolation and identification, error message interpretation, issue resolution, and software maintenance on ProLiant servers and server blades. This guide includes problem-specific flowcharts to help you navigate complex troubleshooting processes. To view the guide, select a language:

- English (http://www.hp.com/support/ProLiant_TSG_en)
- French (http://www.hp.com/support/ProLiant_TSG_fr)
- Italian (http://www.hp.com/support/ProLiant_TSG_it)
- Spanish (http://www.hp.com/support/ProLiant_TSG_sp)
- German (http://www.hp.com/support/ProLiant_TSG_gr)
- Dutch (http://www.hp.com/support/ProLiant_TSG_nl)
- Japanese (http://www.hp.com/support/ProLiant_TSG_jp)

Array Diagnostic Utility

The HP Array Diagnostics Utility is a web-based application that creates a report of all HP storage controllers and disk drives. This report provides vital information to assist in identifying faults or conditions that may require attention. ADU can be accessed from the SmartStart CD or downloaded from the HP website (<http://www.hp.com>).

HP Instant Support Enterprise Edition

ISEE is a proactive remote monitoring and diagnostic tool to help manage your systems and devices, a feature of HP support. ISEE provides continuous hardware event monitoring and automated notification to identify and prevent potential critical problems. Through remote diagnostic scripts and vital system configuration information collected about your systems, ISEE enables fast restoration of your systems. Install ISEE on your systems to help mitigate risk and prevent potential critical problems.

For more information on ISEE, refer to the HP website (http://www.hp.com/hps/hardware/hw_enterprise.html).

To download HP ISEE, visit the HP website (http://www.hp.com/hps/hardware/hw_downloads.html).

For installation information, refer to the HP ISEE Client Installation and Upgrade Guide (ftp://ftp.hp.com/pub/services/hardware/info/isee_client.pdf).

HP Insight Diagnostics survey functionality

HP Insight Diagnostics (on page 64) provides survey functionality that gathers critical hardware and software information on ProLiant servers.

This functionality supports operating systems that may not be supported by the server. For operating systems supported by the server, see the HP website (<http://www.hp.com/go/supportos>).

If a significant change occurs between data-gathering intervals, the survey function marks the previous information and overwrites the survey data files to reflect the latest changes in the configuration.

Survey functionality is installed with every SmartStart-assisted HP Insight Diagnostics installation, or it can be installed through the HP PSP.

NOTE: The current version of SmartStart provides the memory spare part numbers for the server. To download the latest version, see the HP website (<http://www.hp.com/support>).

HP ROM-Based Setup Utility

RBSU is a configuration utility embedded in ProLiant servers that performs a wide range of configuration activities that can include the following:

- Configuring system devices and installed options
- Enabling and disabling system features
- Displaying system information
- Selecting the primary boot controller
- Configuring memory options
- Language selection

For more information on RBSU, see the *HP ROM-Based Setup Utility User Guide* on the Documentation CD or the HP website (<http://www.hp.com/support/smartstart/documentation>).

Integrated Management Log

The IML records hundreds of events and stores them in an easy-to-view form. The IML timestamps each event with 1-minute granularity.

You can view recorded events in the IML in several ways, including the following:

- From within HP SIM ("HP Systems Insight Manager" on page 64)
- From within Survey Utility
- From within operating system-specific IML viewers
 - For NetWare: IML Viewer
 - For Windows®: IML Viewer
 - For Linux: IML Viewer Application
- From within the iLO 2 user interface
- From within HP Insight Diagnostics (on page 64)

For more information, refer to the Management CD in the HP ProLiant Essentials Foundation Pack.

Automatic Server Recovery

ASR is a feature that causes the system to restart when a catastrophic operating system error occurs, such as a blue screen, ABEND, or panic. A system fail-safe timer, the ASR timer, starts when the System Management driver, also known as the Health Driver, is loaded. When the operating system is functioning properly, the system periodically resets the timer. However, when the operating system fails, the timer expires and restarts the server.

ASR increases server availability by restarting the server within a specified time after a system hang or shutdown. At the same time, the HP SIM console notifies you by sending a message to a designated pager number that ASR has restarted the system. You can disable ASR from the HP SIM console or through RBSU.

HP Systems Insight Manager

HP SIM is a web-based application that allows system administrators to accomplish normal administrative tasks from any remote location, using a web browser. HP SIM provides device management capabilities that consolidate and integrate management data from HP and third-party devices.



IMPORTANT: You must install and use HP SIM to benefit from the Pre-Failure Warranty for processors, SAS and SCSI hard drives, and memory modules.

For additional information, refer to the Management CD in the HP ProLiant Essentials Foundation Pack or the HP SIM website (<http://www.hp.com/go/hpsim>).

HP Insight Diagnostics

HP Insight Diagnostics is a proactive server management tool, available in both offline and online versions, that provides diagnostics and troubleshooting capabilities to assist IT administrators who verify server installations, troubleshoot problems, and perform repair validation.

HP Insight Diagnostics Offline Edition performs various in-depth system and component testing while the OS is not running. To run this utility, launch the SmartStart CD.

HP Insight Diagnostics Online Edition is a web-based application that captures system configuration and other related data needed for effective server management. Available in Microsoft® Windows® and Linux versions, the utility helps to ensure proper system operation.

For more information or to download the utility, refer to the HP website (<http://www.hp.com/servers/diags>).

Web-Based Enterprise Service

WEBES enables administrators to manage hardware events proactively, either locally or online. The service provides real-time multiple event analysis, crash analysis, and notification, locally through SMTP and remotely through ISEE for OpenVMS, Tru64, and Microsoft® Windows® operating system binary error logs.

For more information, refer to the HP website (<http://h18000.www1.hp.com/support/svctools/>).

Open Services Event Manager

OSEM is a standalone tool that performs real-time reactive and proactive service event filtering, analysis, and notification. The tool gathers event data from SNMP traps or information provided over an HTTP interface and notifies an administrator or HP through SMTP and ISEE.

For more information, refer to the HP website (<http://h18000.www1.hp.com/support/svctools/>).

Component identification

Front panel components

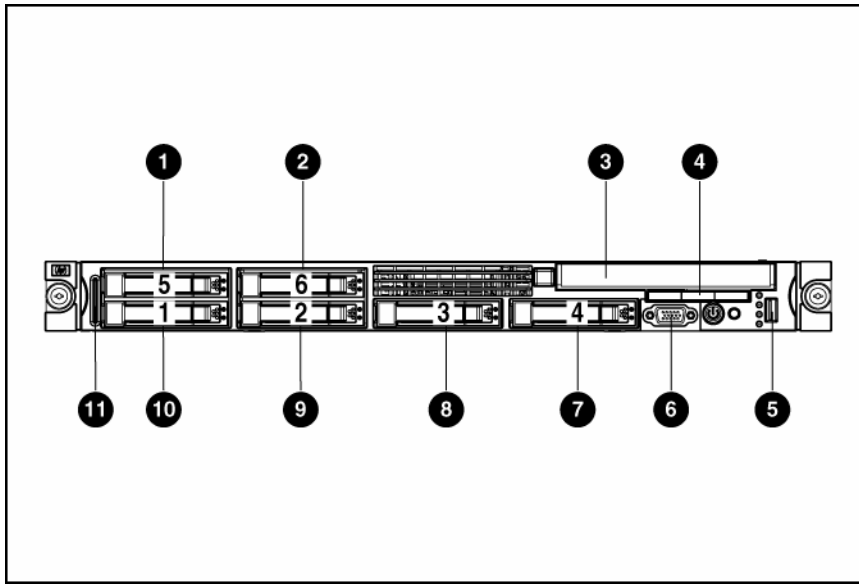

Item	Description
1	Hard drive bay 5 (optional)*
2	Hard drive bay 6 (optional)*
3	Multibay drive bay
4	HP Systems Insight Display
5	USB connector
6	Video connector
7	Hard drive bay 4
8	Hard drive bay 3
9	Hard drive bay 2
10	Hard drive bay 1
11	Serial pull tab

*An optional controller is required when the server is configured with six hard drives.

Front panel LEDs and buttons

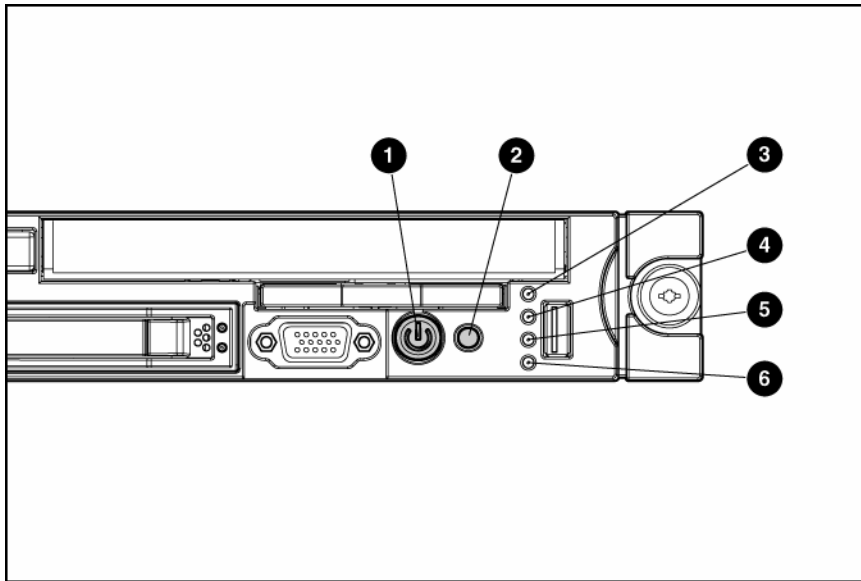

Item	Description	Status
1	Power On/Standby button and system power LED	<p>Green = System is on.</p> <p>Amber = System is shut down, but power is still applied.</p> <p>Off = Power cord is not attached, power supply failure has occurred, no power supplies are installed, facility power is not available, or disconnected power button cable.</p>
2	UID button/LED	<p>Blue = Identification is activated.</p> <p>Flashing blue = System is being remotely managed.</p> <p>Off = Identification is deactivated.</p>
3	Internal health LED	<p>Green = System health is normal.</p> <p>Amber = System health is degraded. To identify the component in a degraded state, see "HP Systems Insight Display and LEDs (on page 71)."</p> <p>Red = System health is critical. To identify the component in a critical state, see "HP Systems Insight Display and LEDs (on page 71)."</p> <p>Off = System health is normal (when in standby mode).</p>
4	External health LED (power supply)	<p>Green = Power supply health is normal.</p> <p>Amber = Power redundancy failure occurred.</p> <p>Off = Power supply health is normal when in standby mode.</p>
5	NIC 1 link/activity LED	<p>Green = Network link exists.</p> <p>Flashing green = Network link and activity exist.</p> <p>Off = No link to network exists.</p> <p>If power is off, the front panel LED is not active. View the LEDs on the RJ-45 connector for status by referring to the rear panel LEDs ("Rear panel LEDs and buttons" on page 69).</p>

Item	Description	Status
6	NIC 2 link/activity LED	<p>Green = Network link exists.</p> <p>Flashing green = Network link and activity exist.</p> <p>Off = No link to network exists.</p> <p>If power is off, the front panel LED is not active. View the LEDs on the RJ-45 connector for status by referring to the rear panel LEDs ("Rear panel LEDs and buttons" on page 69).</p>

Rear panel components

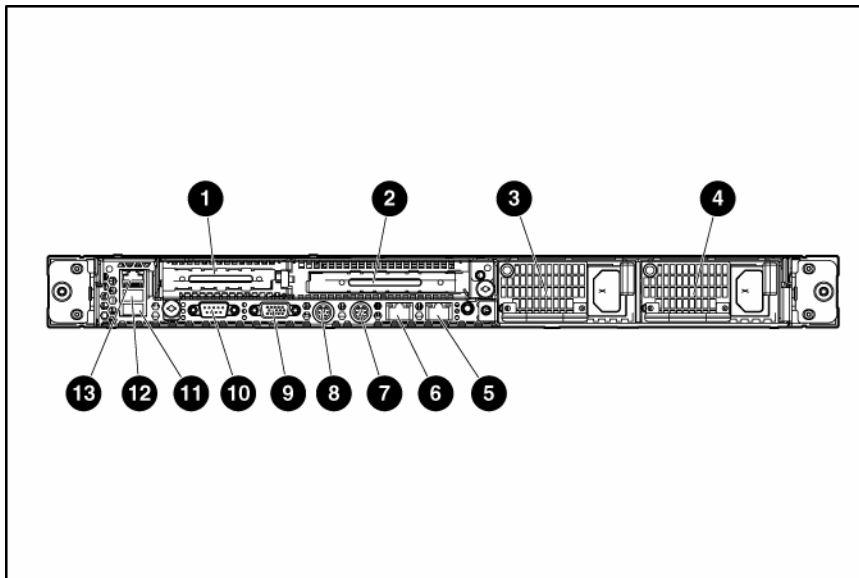

Item	Description
1	PCI Express expansion slot 1, low-profile, half-length
2	PCI Express expansion slot 2
3	Power supply bay 2
4	Power supply bay 1
5	NIC 2 connector
6	NIC 1 connector
7	Keyboard connector
8	Mouse connector
9	Video connector
10	Serial connector
11	USB connector
12	USB connector
13	iLO 2 NIC connector

Rear panel LEDs and buttons

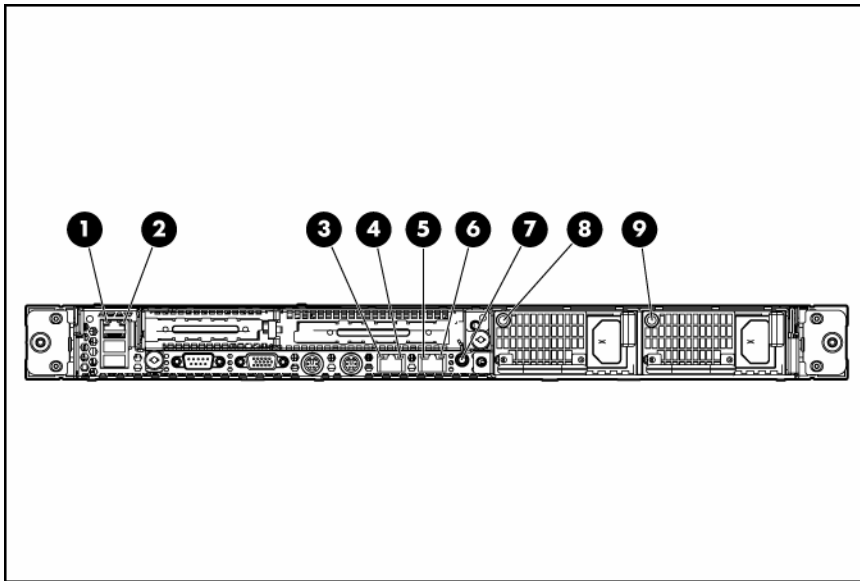

Item	Description	Status
1	iLO 2 NIC activity LED	Green = Activity exists. Flashing green = Activity exists. Off = No activity exists.
2	iLO 2 NIC link LED	Green = Link exists. Off = No link exists.
3	10/100/1000 NIC 1 activity LED	Green = Activity exists. Flashing green = Activity exists. Off = No activity exists.
4	10/100/1000 NIC 1 link LED	Green = Link exists. Off = No link exists.
5	10/100/1000 NIC 2 activity LED	Green = Activity exists. Flashing green = Activity exists. Off = No activity exists.
6	10/100/1000 NIC 2 link LED	Green = Link exists. Off = No link exists.
7	UID button/LED	Blue = Identification is activated. Flashing blue = System is being managed remotely. Off = Identification is deactivated.
8	Power supply 2 LED	Green = Normal Off = System is off or power supply has failed
9	Power supply 1 LED	Green = Normal Off = System is off or power supply has failed

System board components

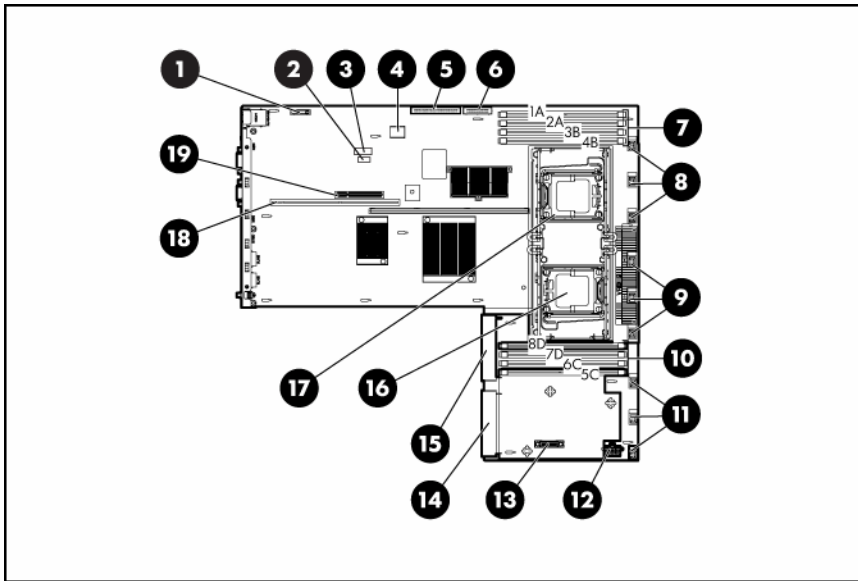

Item	Description
1	System battery
2	NMI jumper
3	System maintenance switch (SW1)
4	Internal USB connector
5	Multibay connector
6	Power switch connector
7	DIMM slots (1-4)
8	Fan module 3 connectors
9	Fan module 2 connectors
10	DIMM slots (5-8)
11	Fan module 1 connectors
12	SFF hard drive backplane power connector
13	Integrated Smart Array controller connector
14	Power supply connector 1
15	Power supply connector 2
16	Processor socket 2
17	Processor socket 1 (populated)
18	PCI riser board connector 2
19	PCI riser board connector 1

System maintenance switch

Position	Default	Function
S1	Off	Off = iLO 2 security is enabled. On = iLO 2 security is disabled.
S2	Off	Off = System configuration can be modified. On = System configuration is locked and cannot be modified.
S3	Off	Reserved
S4	Off	Reserved
S5	Off	Off = Power-on password is enabled. On = Power-on password is disabled.
S6	Off	Off = Normal On = ROM treats system configuration as invalid.
S7	Off	Reserved
S8	Off	Reserved

When the system maintenance switch position 6 is set to the On position, the system is prepared to erase all system configuration settings from both CMOS and NVRAM.

 **CAUTION:** Clearing CMOS and/or NVRAM deletes configuration information. Be sure to properly configure the server or data loss could occur.

NMI jumper

The NMI jumper allows administrators to perform a memory dump before performing a hard reset. Crash dump analysis is an essential part of eliminating reliability problems, such as hangs or crashes in OSs, device drivers, and applications. Many crashes can freeze a system, requiring you to do a hard reset. Resetting the system erases any information that would support root cause analysis.

Systems running Microsoft® Windows® experience a blue-screen trap when the OS crashes. When this happens, Microsoft® recommends that system administrators perform an NMI event by temporarily shorting the NMI header with a jumper. The NMI event enables a hung system to become responsive again.

HP Systems Insight Display and LEDs

The display provides status for all internal LEDs and enables diagnosis with the access panel installed.

To view the LEDs, access the HP Systems Insight Display.

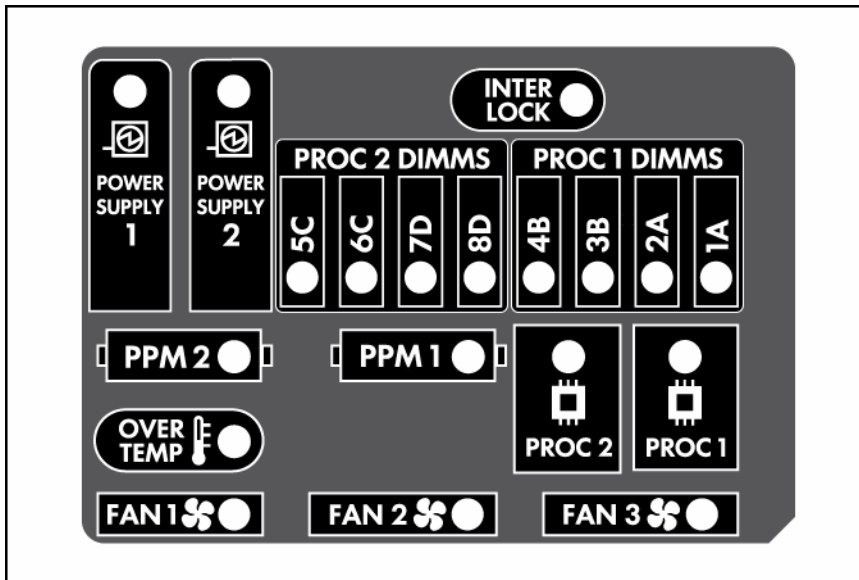

LED	Status
Off	Normal
Amber	Failure

For additional information about these LEDs, see "HP Systems Insight Display LEDs and internal health LED combinations (on page 72)."

NOTE: The HP Systems Insight Display LEDs represent the system board layout.

HP Systems Insight Display LEDs and internal health LED combinations

When the internal health LED on the front panel illuminates either amber or red, the server is experiencing a health event. Combinations of illuminated system LEDs and the internal health LED indicate system status.

The front panel health LEDs indicate only the current hardware status. In some situations, HP SIM may report server status differently than the health LEDs because the software tracks more system attributes.

HP Systems Insight Display LED and color	Internal health LED color	Status
Processor failure, socket X (amber)	Red	One or more of the following conditions may exist: <ul style="list-style-type: none"> Processor in socket X has failed. Processor X is required yet not installed in the socket. Processor X is unsupported.
	Amber	Processor in socket X is in a pre-failure condition.
Processor failure, both sockets (amber)	Red	Processor types are mismatched.

HP Systems Insight Display LED and color	Internal health LED color	Status
PPM failure (amber)	Red	Integrated PPM has failed.
DIMM failure, slot X (amber)	Red	One or more of the following conditions may exist: <ul style="list-style-type: none"> DIMM in slot X has failed. DIMM in slot X is an unsupported type, and no valid memory exists in another bank.
	Amber	One or more of the following conditions may exist: <ul style="list-style-type: none"> DIMM in slot X has reached single-bit correctable error threshold. DIMM in slot X is in a pre-failure condition. DIMM in slot X is an unsupported type, but valid memory exists in another bank.
DIMM failure, all slots (amber)	Red	No valid or usable memory is installed in the system.
Overtemperature (amber)	Amber	The health driver has detected a cautionary temperature level.
	Red	The server has detected a critical temperature level.
Riser interlock (amber)	Red	The PCI riser board assembly is not seated properly.
Fan module (amber)	Amber	A redundant fan has failed.
Fan module (amber)	Red	The minimum fan requirements are not being met in one or more of the fan modules. One or more fans have failed or are missing.

SAS and SATA device numbers

- Four hard drive configuration

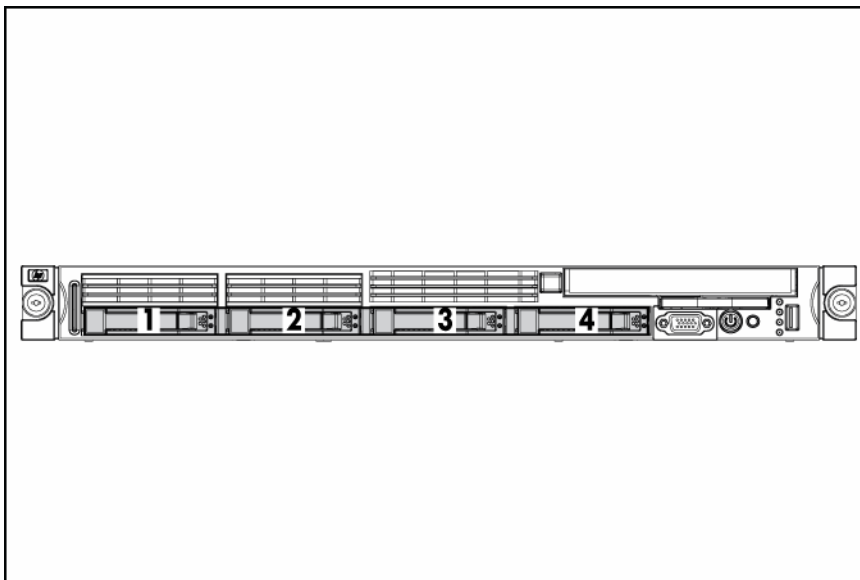

- Six hard drive configuration

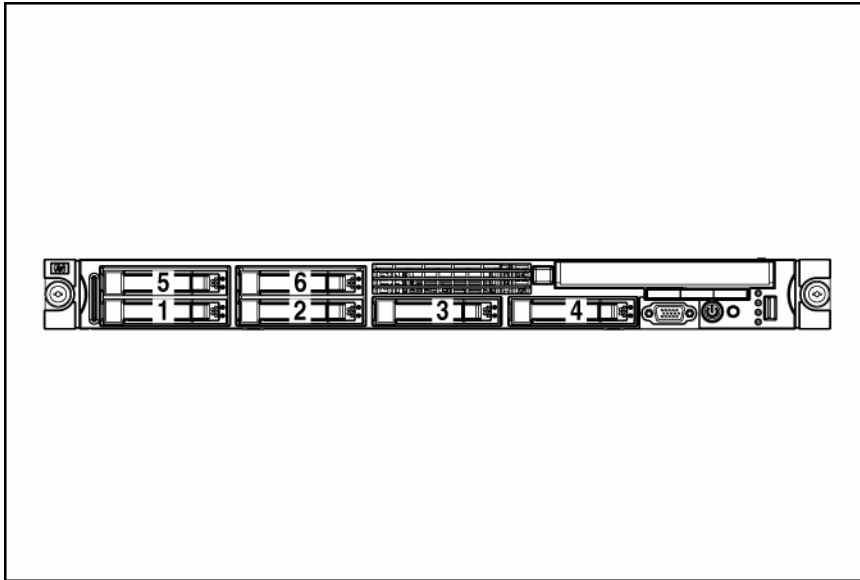

SAS and SATA hard drive LEDs

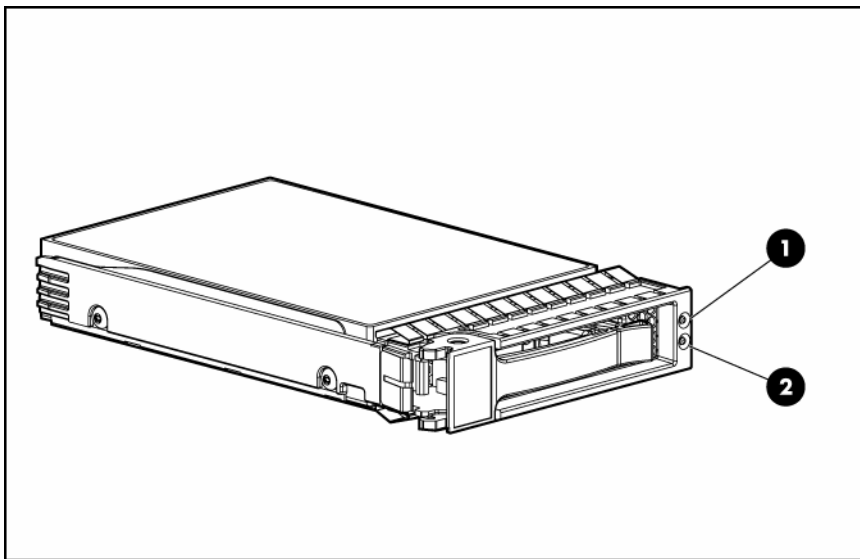

Item	Description
1	Fault/UID LED (amber/blue)
2	Online LED (green)

SAS and SATA hard drive LED combinations

Online/activity LED (green)	Fault/UID LED (amber/blue)	Interpretation
On, off, or flashing	Alternating amber and blue	The drive has failed, or a predictive failure alert has been received for this drive; it also has been selected by a management application.
On, off, or flashing	Steadily blue	The drive is operating normally, and it has been selected by a management application.
On	Amber, flashing regularly (1 Hz)	A predictive failure alert has been received for this drive. Replace the drive as soon as possible.
On	Off	The drive is online, but it is not active currently.
Flashing regularly (1 Hz)	Amber, flashing regularly (1 Hz)	Do not remove the drive. Removing a drive may terminate the current operation and cause data loss. The drive is part of an array that is undergoing capacity expansion or stripe migration, but a predictive failure alert has been received for this drive. To minimize the risk of data loss, do not replace the drive until the expansion or migration is complete.
Flashing regularly (1 Hz)	Off	Do not remove the drive. Removing a drive may terminate the current operation and cause data loss. The drive is rebuilding, or it is part of an array that is undergoing capacity expansion or stripe migration.
Flashing irregularly	Amber, flashing regularly (1 Hz)	The drive is active, but a predictive failure alert has been received for this drive. Replace the drive as soon as possible.
Flashing irregularly	Off	The drive is active, and it is operating normally.
Off	Steadily amber	A critical fault condition has been identified for this drive, and the controller has placed it offline. Replace the drive as soon as possible.
Off	Amber, flashing regularly (1 Hz)	A predictive failure alert has been received for this drive. Replace the drive as soon as possible.
Off	Off	The drive is offline, a spare, or not configured as part of an array.

Fan locations

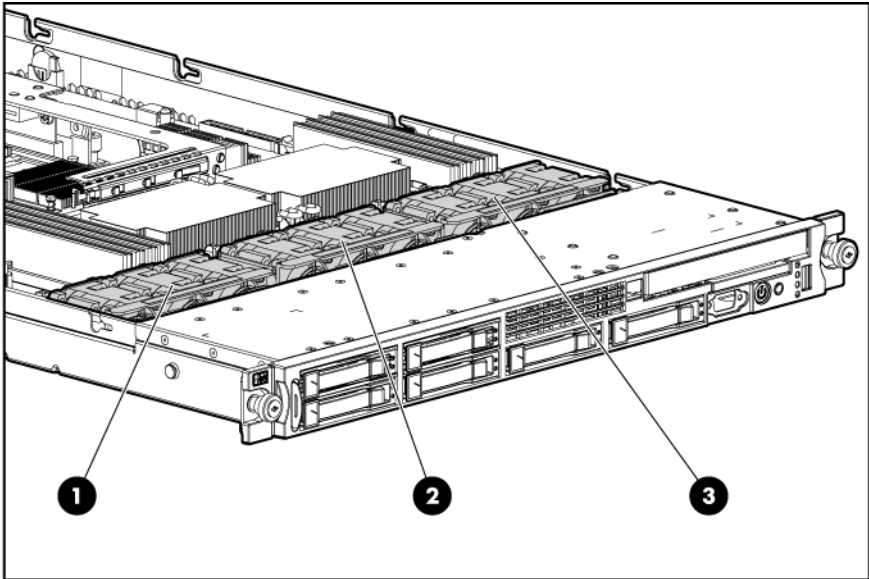

Item	Description
1	Fan module 1
2	Fan module 2
3	Fan module 3

Specifications

Environmental specifications

Specification	Value
Temperature range*	
Operating	10°C to 35°C (50°F to 95°F)
Shipping	-40°C to 70°C (-40°F to 158°F)
Maximum wet bulb temperature	28°C (82.4°F)
Relative humidity (noncondensing)**	
Operating	10% to 90%
Non-operating	5% to 95%

* All temperature ratings shown are for sea level. An altitude derating of 1°C per 300 m (1.8°F per 1,000 ft) to 3048 m (10,000 ft) is applicable. No direct sunlight allowed.

** Storage maximum humidity of 95% is based on a maximum temperature of 45°C (113°F). Altitude maximum for storage corresponds to a pressure minimum of 70 KPa.

Server specifications

Specification	Value
Dimensions	
Height	4.32 cm (1.70 in)
Depth	69.22 cm (27.25 in)
Width	42.62 cm (16.78 in)
Weight (maximum: two processors, two power supplies, six hard drives)	17.92 kg (39.50 lb)
Weight (minimum: one processor, one power supply, no hard drives)	14.51 kg (32.00 lb)
Weight (no drives installed)	14.06 kg (31.00 lb)
Input requirement	
Rated input voltage	100 VAC to 240 VAC
Rated input frequency	50 Hz to 60 Hz
Rated input current	7.1A (at 120 VAC); 3.5A (at 240 VAC)
Rated input power	852 W
BTUs per hour	2910 (at 120 VAC); 2870 (at 240 VAC)
Power supply output	

Specification	Value
Rated steady-state power	700 W

Hot-plug power supply calculations

For hot-plug power supply specifications and calculators to determine electrical and heat loading for the server, refer to the HP Enterprise Configurator website (<http://h30099.www3.hp.com/configurator/>).

DDR2 SDRAM DIMM specifications



CAUTION: Be sure to install DIMMs in the proper configuration. Refer to the Documentation CD.

Item	Description
Size*	512-MB, 1-GB, 2-GB, 4-GB
Width	64 bits

*Use only 512-MB, 1-GB, 2-GB, or 4-GB, 72-bit wide, 1.8-V, PC2-5300 Unbuffered ECC DDR2 DIMMs. Use HP DDR2 DIMMs only.

1.44-MB diskette drive specifications

Specification	Value
Dimensions	
Height	12.7 mm (0.5 in)
Width	96 mm (3.8 in)
Depth	130 mm (5.1 in)
LEDs (front panel)	Green = On
Read/write capacity per diskette	
High density	1.44 MB
Low density	720 KB
Drives supported	1
Drive height	One-third height
Drive rotation	300 rpm
Transfer rate	
High	500 Kb/s
Low	250 Kb/s
Bytes/sector	512
Sectors per track (high/low)	18/9
Tracks per side (high/low)	80/80
Access times	

Specification	Value
Track-to-track (high/low)	3 ms/6 ms
Average (high/low)	169 ms/94 ms
Setting time	15 ms
Latency average	100 ms
Cylinders (high/low)	80/80
Read/write heads	2

CD-ROM drive specifications

Specification	Value
Disk formats	CD-ROM (modes 1 and 2); mixed mode (audio and data combined); CD-DA; Photo CD (single/multiple-session), CD-XA ready; CDi ready
Capacity	550 MB (mode 1, 12 cm)
	640 MB (mode 2, 12 cm)
Block size	2368, 2352 bytes (mode 0)
	2352, 2340, 2336, 2048 bytes (mode 1)
	2352, 2340, 2336, 2048 bytes (mode 2)
Dimensions	
Height	12.7 mm (0.50 in)
Depth	132.08 mm (5.20 in)
Width	132.08 mm (5.20 in)
Weight	0.34 kg (0.75 lb)
Data transfer rate	
Sustained	150 KB/s (sustained 1X), 1500/3600 KB/s (10X to 24X)
Burst	16.6 MB/s
Access times (typical)	
Full stroke	300 ms
Random	140 ms
Diameter	12 cm, 8 cm (4.70 in, 3.15 in)
Thickness	1.2 mm (0.05 in)
Track pitch	1.6 μm (6.3×10^{-7} in)
Cache/buffer	128 KB
Startup time	< 10 s
Stop time	< 5 s (single); < 30 s (multisession)
Laser parameters	
Type	Semiconductor laser GaAs
Wave length	700 \pm 25 nm
Divergence angle	53.5° \pm 1.5°
Output power	0.14 mW

Specification	Value
Operating conditions	
Temperature	5°C to 45°C (41°F to 118°F)
Humidity	5% to 90%

DVD-ROM drive specifications

Specification	Value
Disk formats	DVD (single and double layer), DVD-5, DVD-9, DVD-10, DVD-R, CD-ROM Mode 1 & 2, CD-DA, CD-XA (Mode 2, Form 1 & 2), CD-I (Mode 2, Form 1 & 2), CD-I ready, CD-Bridge, CD-R, PhotoCD (single and multi-session)
Capacity	4.7 GB (DVD-5), 8.5 GB (DVD-9), 9.4 GB (DVD10), 550 Mb (Mode 1, 12 cm), 640 Mb (Mode 2, 12 cm), 180 Mb (8 cm)
Block size	2352 bytes (mode 0) 2352, 2340, 2336, 2048 bytes (mode 1) 2352, 2340, 2336, 2048 bytes (mode 2) 2048 bytes (DVD)
Dimensions	
Height	12.7 mm (0.50 in)
Depth	132.08 mm (5.20 in)
Width	132.08 mm (5.20 in)
Weight	0.34 kg (0.75 lb)
Data transfer rate	
Sustained	4463 - 10,800 KB/s (8X CAV DVD mode), 150 KB/s (sustained 1X CD-ROM), 1552 3600 KB/s (24X CAV CD-ROM)
Burst	16.6 MB/s with DMA support
Access times (typical)	
Full stroke	<200 ms CD <300 ms DVD
Random	<110 ms CD <180 ms DVD
Diameter	12 cm, 8 cm (4.70 in, 3.15 in)
Thickness	1.2 mm (0.05 in)
Track pitch	0.74 μm (3.15×10^{-7} in) DVD-ROM 1.6 μm (6.3×10^{-7} in) CD-ROM
Cache/buffer	128 KB
Startup time	< 10 s
Stop time	< 5 s (single); < 30 s (multisession)
Laser parameters	
Type	Semiconductor laser GaAs
Wave length	700 \pm 25 nm
Divergence angle	53.5° \pm 1.5°
Output power	0.14 mW

Specification	Value
Operating conditions	
Temperature	5°C to 45°C (41°F to 118°F)
Humidity	5% to 90%

SAS hard drive specifications

Item	36-GB SAS drive	72-GB SAS drive	146-GB SAS drive
Capacity	36,420 MB	73,408 MB	146,815 MB
Height	25.4 mm (1.0 in)	25.4 mm (1.0 in)	25.4 mm (1.0 in)
Interface	SAS	SAS	SAS
Transfer rate	3 Gb/sec	3 Gb/sec	3 Gb/sec
Rotational speed	15,000 rpm	15,000 rpm	15,000 rpm
Bytes per sector	512	512	512
Logical blocks	71,132,959	143,374,737	286,749,487
Operating temperature	10° to 35°C (50° to 95°F)	10° to 35°C (50° to 95°F)	10° to 35°C (50° to 95°F)

SATA hard drive specifications

Item	80-GB SATA	160-GB SATA	250-GB SATA	500-GB SATA
Capacity	80,026 MB	160,041 MB	250,059 MB	500,107 MB
Height	2.611 cm (1.028 in)	2.611 cm (1.028 in)	2.611 cm (1.028 in)	2.611 cm (1.028 in)
Interface	Serial ATA	Serial ATA	Serial ATA	Serial ATA
Transfer rate	1.5 Gb/sec	1.5 Gb/sec	1.5 Gb/sec	1.5 Gb/sec
Rotational speed	7,200 rpm	7,200 rpm	7,200 rpm	7,200 rpm
Bytes per sector	512	512	512	512
Logical blocks	156,301,488	312,581,808	488,397,168	976,773,168
Operating temperature	5° to 55°C (41° to 131°F)	5° to 55°C (41° to 131°F)	5° to 55°C (41° to 131°F)	5° to 55°C (41° to 131°F)

Acronyms and abbreviations

ABEND

abnormal end

ASR

Automatic Server Recovery

BBWC

battery-backed write cache

DDR

double data rate

IML

Integrated Management Log

NIC

network interface controller

NVRAM

non-volatile memory

OSEM

Open Services Event Manager

PCI Express

Peripheral Component Interconnect Express

PCI-X

peripheral component interconnect extended

PPM

processor power module

PSP

ProLiant Support Pack

RBSU

ROM-Based Setup Utility

SAS

serial attached SCSI

SATA

serial ATA

SFF

small form-factor

SIM

Systems Insight Manager

UID

unit identification

USB

universal serial bus

Index

A

access panel 30
additional information 62
ADU (Array Diagnostic Utility) 62
air baffle 25, 31
array controller, cabling 58, 59
array controller, removing 41
Array Diagnostic Utility (ADU) 62
ASR (Automatic Server Recovery) 64
Automatic Server Recovery (ASR) 64

B

backplane, SAS 35
battery tray 32
battery-backed write cache battery pack 33, 60
bezel, front 27
buttons 66, 67

C

cabling 58, 60
cabling, battery pack 60
cabling, controller 58, 59
cautions 24
CD-ROM drive 79
component identification 66, 74
components 16, 19, 66
components, mechanical 16
components, system 19
connectors 66, 67
CSR (customer self repair) 5
customer self repair (CSR) 5

D

diagnostic tools 62, 64
diagnostics utility 64
DIMMs 42
diskette drive 78
DVD-ROM drive 80

E

electrostatic discharge 23
environmental requirements 77
environmental specifications 77
expansion boards 39
extending server from rack 25
external health LED 67

F

fan modules 31
features 66
front bezel 27
front panel buttons 67
front panel LEDs 67

H

hard drive bezel blanks 28
hard drive blanks 26, 28
hard drive LEDs 74, 75
hard drives 73, 74, 75
hard drives, determining status of 74, 75
health driver 64, 72
health LEDs 74, 75
heatsink 43
HP Insight Diagnostics 63, 64
HP ProLiant Essentials Foundation Pack 64
HP Systems Insight Manager, overview 64

I

iLO connector 71
IML (Integrated Management Log) 63
Insight Diagnostics 63, 64
integrated array controller 41
Integrated Management Log (IML) 63
internal health LED 72, 74, 75

L

LED, external health 67
LED, iLO NIC 69
LED, internal health 67

LEDs 66, 75
LEDs, hard drive 74, 75
LEDs, NIC 67, 69
LEDs, power button/LED board 67
LEDs, unit identification (UID) 67

M

management tools 62
mechanical components 16
multibay backplane assembly 35
multibay blank, removing 34
multibay/SAS backplane, removing 35

N

NIC LEDs 67

P

PCI array controllers, cabling 58
PCI Express riser boards 40
PCI riser board assembly 38
power LEDs, system 67
Power On/Standby button 25, 67
power requirements 78
power supplies 29, 78
power supply blank 30
powering down 25
PPM failure LEDs 73
preparation procedures 25
processor 44

R

RBSU (ROM-Based Setup Utility) 63
riser board 40

S

safety considerations 23
SAS backplane 36
SAS hard drive 27
SAS hard drive LEDs 74, 75
SATA drives 73
SATA hard drive 27, 75
SATA hard drive LEDs 74, 75
specifications, environmental 77
specifications, server 77, 78
static electricity 23
symbols on equipment 23
system board 51
system board components 71

system components 19
system maintenance switch 71
system power LED 67, 71
Systems Insight Display 71
Systems Insight Display LEDs 71, 72
Systems Insight Manager 64

T

troubleshooting 62

U

UID LED 25
utilities 62
utilities, deployment 63

W

warnings 24

Free Manuals Download Website

<http://myh66.com>

<http://usermanuals.us>

<http://www.somanuals.com>

<http://www.4manuals.cc>

<http://www.manual-lib.com>

<http://www.404manual.com>

<http://www.luxmanual.com>

<http://aubethermostatmanual.com>

Golf course search by state

<http://golfingnear.com>

Email search by domain

<http://emailbydomain.com>

Auto manuals search

<http://auto.somanuals.com>

TV manuals search

<http://tv.somanuals.com>