



**HEWLETT
PACKARD**

OPERATING AND SERVICE MANUAL

8165A PROGRAMMABLE SIGNAL SOURCE

(Including Options 002 and 907 to 910)

SERIAL NUMBERS

This manual applies directly to instruments with serial number 1904 G 00601 and higher. Any changes made in instruments having serial numbers higher than the above number will be found in a "Manual Changes" supplement supplied with this manual. Be sure to examine this supplement for any changes which apply to your instrument and record these changes in the manual. Backdating information for instruments with lower serial numbers will be found in Section 7.

© HEWLETT-PACKARD GMBH 1979
HERRENBERGER STR. 110, D-7030 BÖBLINGEN
FEDERAL REPUBLIC OF GERMANY

MANUAL PART NO. 08165-90003
Microfiche Part No. 08165-95003

Printed: Oct. 1979

CERTIFICATION

Hewlett-Packard Company certifies that this product met its published specifications at the time of shipment from the factory. Hewlett-Packard further certifies that its calibration measurements are traceable to the United States National Bureau of Standards, to the extent allowed by the Bureau's calibration facility, and to the calibration facilities of other International Standards Organization members.

WARRANTY

This Hewlett-Packard product is warranted against defects in material and workmanship for a period of one year from date of shipment. During the warranty period, Hewlett-Packard Company will, at its option, either repair or replace products which prove to be defective.

HP warrants that its software and firmware designated by HP for use with an instrument will execute its programming instructions when properly installed on that instrument. HP does not warrant that the operation of the instrument, or software, or firmware will be uninterrupted or error free.

For products returned to HP for warranty service, Buyer shall prepay shipping charges to HP and HP shall pay shipping charges to return the product to Buyer. However, Buyer shall pay all shipping charges, duties, and taxes for products returned to HP from another country.

LIMITATION OF WARRANTY

The foregoing warranty shall not apply to defects resulting from improper or inadequate maintenance by Buyer, Buyer-supplied software or interfacing, unauthorized modification or misuse, operation outside of the environmental specifications for the product, or improper site preparation or maintenance.

NO OTHER WARRANTY IS EXPRESSED OR IMPLIED. HP SPECIFICALLY DISCLAIMS THE IMPLIED WARRANTIES OF MERCHANTABILITY AND FITNESS FOR A PARTICULAR PURPOSE.

EXCLUSIVE REMEDIES

THE REMEDIES PROVIDED HEREIN ARE BUYER'S SOLE AND EXCLUSIVE REMEDIES. HP SHALL NOT BE LIABLE FOR ANY DIRECT, INDIRECT, SPECIAL, INCIDENTAL, OR CONSEQUENTIAL DAMAGES, WHETHER BASED ON CONTRACT, TORT, OR ANY OTHER LEGAL THEORY.

ASSISTANCE

Product maintenance agreements and other customer assistance agreements are available for Hewlett-Packard products.

For any assistance, contact your nearest Hewlett-Packard Sales and Service Office. Addresses are provided at the back of this manual.

SAFETY SUMMARY

The following general safety precautions must be observed during all phases of operation, service, and repair of this instrument. Failure to comply with these precautions or with specific warnings elsewhere in this manual violates safety standards of design, manufacture, and intended use of the instrument. Hewlett-Packard Company assumes no liability for the customer's failure to comply with these requirements.

GENERAL — This is a Safety Class I instrument (provided with terminal for protective earthing) and has been manufactured and tested according to international safety standards.

OPERATION — BEFORE APPLYING POWER comply with the installation section. Additionally, the following shall be observed:

Do not remove instrument covers when operating.
Before the instrument is switched on, all protective earth terminals, extension cords, auto-transformers and devices connected to it should be connected to a protective earth via a ground socket. Any interruption of the protective earth grounding will cause a potential shock hazard that could result in serious personal injury. Whenever it is likely that the protection has been impaired, the instrument must be made inoperative and be secured against any unintended operation.

Make sure that only fuses with the required rated current and of the specified type (normal blow, time delay, etc.) are used for replacement. The use of repaired fuses and the short-circuiting of fuseholders must be avoided.

Adjustments described in the manual are performed with power supplied to the instrument while protective covers are removed. Energy available at many points may, if contacted, result in personal injury.

Any adjustment, maintenance, and repair of the opened instrument under voltage should be avoided as much as possible, and when inevitable, should be carried out only by a skilled person who is aware of the hazard involved. Do not attempt internal service or adjustment unless another person, capable of rendering first aid and resuscitation is present. Do not replace components with power cable connected.

Do not operate the instrument in the presence of flammable gases or fumes. Operation of any electrical instrument in such an environment constitutes a definite safety hazard.

Do not install substitute parts or perform any unauthorized modification to the instrument.

Capacitors inside the instrument may still be charged even if the instrument has been disconnected from its source of supply.

To prevent CRT implosion, avoid rough handling or jarring of the instrument. Handling of the CRT shall be done only by qualified maintenance personnel using approved safety mask and gloves.

SAFETY SYMBOLS



The apparatus will be marked with this symbol when it is necessary for the user to refer to the instruction manual in order to protect the apparatus against damage.



Indicates dangerous voltages.



Earth terminal

WARNING

The **WARNING** sign denotes a hazard. It calls attention to a procedure, practice or the like, which, if not correctly performed or adhered to, could result in injury or loss of life. Do not proceed beyond a **WARNING** sign until the indicated conditions are fully understood and met.

CAUTION

The **CAUTION** sign denotes a hazard. It calls attention to an operating procedure, practice, or the like, which, if not correctly performed or adhered to, could result in damage to or destruction of part or all of the equipment. Do not proceed beyond a **CAUTION** sign until the indicated conditions are fully understood and met.

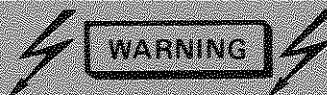

Dangerous voltages, capable of causing serious personal injury, are present in this instrument. Use extreme caution when handling, testing, and adjusting.

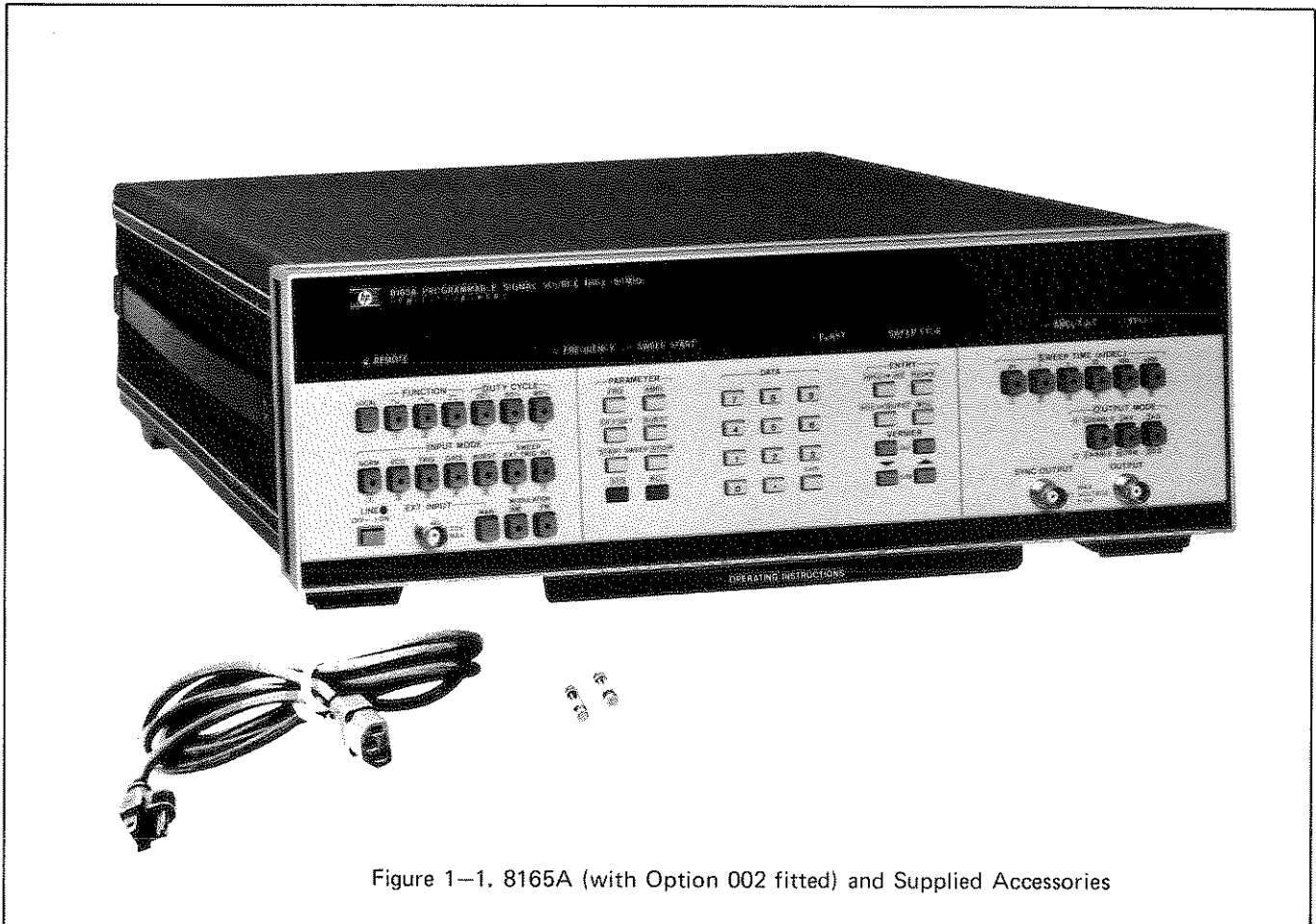

Figure 1-1. 8165A (with Option 002 fitted) and Supplied Accessories

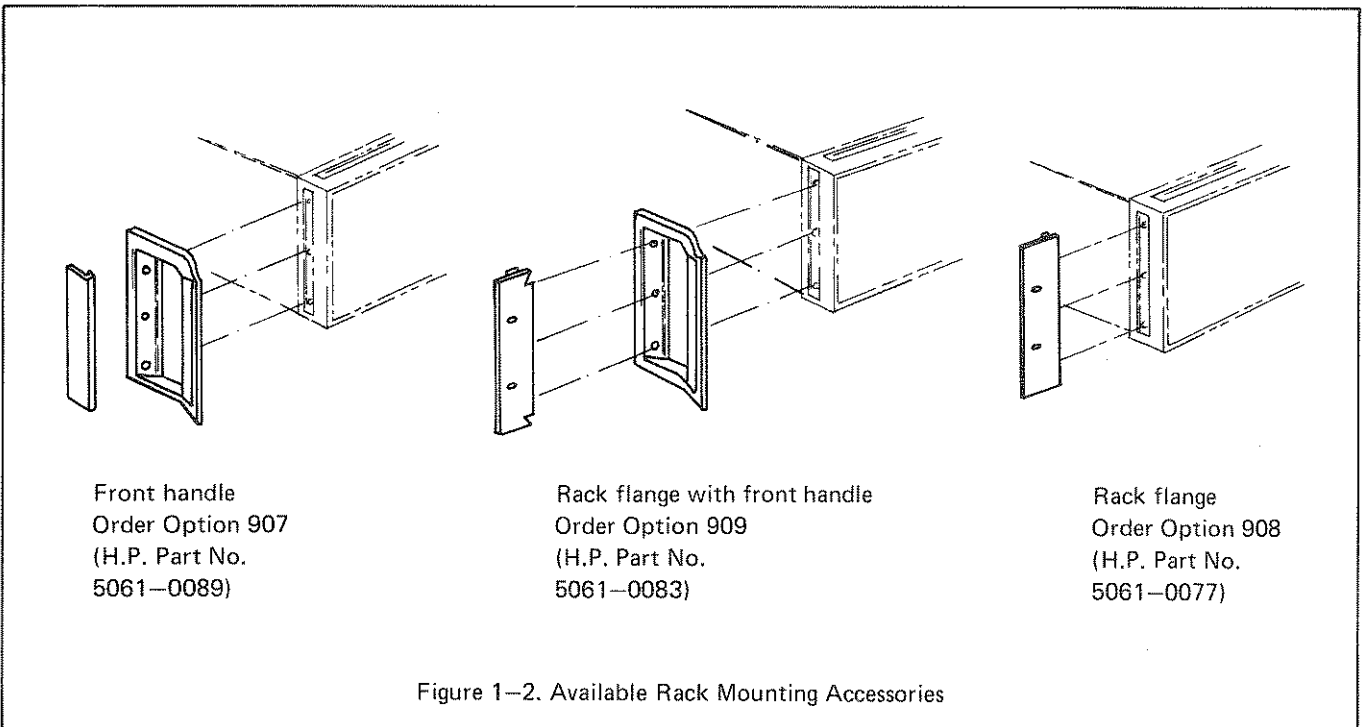

Figure 1-2. Available Rack Mounting Accessories

SECTION I GENERAL INFORMATION

1-1 INTRODUCTION

1-2 This Operating and Service Manual contains information required to install, operate, test, adjust and service the Hewlett-Packard Model 8165A. Figure 1-1 shows the mainframe and accessories supplied. This section covers instrument identification, description, accessories, specifications, and other basic information.

1-3 A Microfiche version of this manual is available on 4 x 6 inch microfilm transparencies (order number on title page). Each microfilm contains up to 60 photo-duplicates of the manual pages. The microfiche package also includes the latest Manual Changes supplement as well as all pertinent Service Notes.

1-4 SPECIFICATIONS

1-5 Instrument specifications are listed in Table 1-2. These specifications are the performance standards or limits against which the instrument is tested.

1-6 SAFETY CONSIDERATIONS

1-7 The Model 8165A is a Safety Class 1 instrument (it has an exposed metal chassis that is directly connected to earth via the power supply cable).

1-8 This operating and service manual contains information, cautions, and warnings which must be followed by the user to ensure safe operation and to maintain the instrument in a safe condition.

1-9 INSTRUMENTS COVERED BY MANUAL

1-10 Attached to the rear of this instrument is a serial number plate (Figure 1-3). The first four digits of the serial number only change when there is a significant change to the instrument. The last five digits are assigned to instruments sequentially. The contents of this manual apply directly to the instrument serial number quoted on the title page. For instruments with lower serial numbers, refer to the backdating information in Section VII of this manual. For instruments with higher serial numbers, refer to the Manual Change sheets at the end of this manual. In addition to change information, the

Manual Change sheets may contain information for correcting errors in the manual. To keep this manual as up-to-date and accurate as possible, Hewlett-Packard recommends that you periodically request the latest Manual Change supplement. The supplement for this manual is identified with this manual's print date and part number, both of which appear on this manual's title page. Complimentary copies of the supplement are available from Hewlett-Packard.

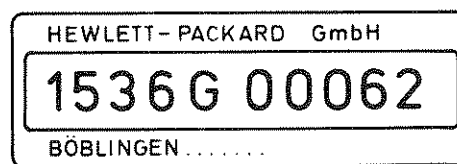

Figure 1-3. Serial Number Plate

1-11 DESCRIPTION

1-12 The HP Model 8165A Programmable Signal Source provides sine, triangle and square waveforms in the frequency range 1 mHz to 50 MHz. Operating modes include: normal (internal trigger), voltage-controlled oscillator, external trigger, gate, burst and FM. Output capabilities include normal/invert, selectable source impedance, variable offset up to ± 10 V and variable amplitude up to ± 20 Vpp. Microprocessor design makes mode selection and parameter setting easy whether done manually or programmed over the HP-IB*. Current operating status, including notification of operating or programming error, is available to the bus and indicated on the front panel.

* *Hewlett-Packard Interface Bus, Hewlett-Packard's implementation of IEEE Standard 488 „Standard Digital Interface for Programmable Instrumentation“.*

1-13 OPTIONS

1-14 **8165A Option 002** provides additional AM feature and up/down logarithmic sweep modes. The sweep modes have selectable start and stop frequencies and the sweep time may be selected from six discrete values. Sweep start may be externally triggered or, for continuous operation, internally triggered.

NOTE: Option 001 (additional sweep mode only) is obsolete. Refer to Backdating.

1-15 8165A Options 907, 908 and 909 provide handles and/or rack mounting accessories. Refer to Figure 1-2.

1-16 8165A Option 910 provides an additional manual.

1-17 All options will be delivered with the instrument if ordered at the same time as the instrument.

1-18 ACCESSORIES SUPPLIED

1-19 The 8165A is supplied complete with the following items (see Figure 1-1):

ITEM	HP PART NUMBER
1A Fuse for 230V operation	2110-0001
2A Fuse for 115V operation	2110-0002
Power cable	see Figure 2-2
User's Reference (inserted in pull-out under instrument)	08165-90011

1-20 RECOMMENDED TEST EQUIPMENT

1-21 Equipment required to maintain the model 8165A is listed in Table 1-1. Other equipment can be substituted if it meets or exceeds the critical specifications listed in the table.

Table 1-1 Recommended Test Equipment

INSTRUMENT	RECOMMENDED MODEL	REQUIRED CHARACTERISTICS	USE*
Counter	HP5345A	50 μ Hz to 50 MHz, 8-digit display	P, A
Digital voltmeter	HP 3455A	0.1-20V, ac rms and dc, 0.004 % accuracy	P, A
Spectrum analyzer	HP181A + 8557A or HP141T + 8552A + 8556A	1-50 MHz	P, A
Spectrum analyzer	HP3580A	100 Hz - 1 MHz	A
Sampling scope	HP180C + 1810A	Dual channel, 2 mV/div, 10 ps - 50 μ /div	P, A
Scope	HP1740A	100 MHz bandwidth	P, A
Pulse generator	HP8012B	1 Hz - 1 MHz, square, pulse, offset	P, A
Voltage source	HP6213A	100 mV - 10V dc	P, A
System controller	HP9825A + 98034A	Desktop computer, HP-IB, Interface	P
Logic analyzer	HP1600A	16-bit	T
Logic probe	HP545A	TTL, MOS	T
Cable assembly (3)	HP11170B	50 Ω , 61cm (24 in), BNC	P, A
Cable assembly (2)	HP11170A	50 Ω , 30cm (12 in), BNC	P, A
Feedthrough termination	HP10100C	50 Ω , BNC	P, A
Power attenuator	Microline 766-20	20dB, 20W	P, A
BNC Tee	HP1250-0781	1 male, 2 female	P, A
Adapter	HP1251-2277	Banana / BNC female	P, A
1:1 Probe	HP10007/8B	BNC / retractable hook	A
10:1 Probe	HP10006B	BNC / retractable hook	A
Capacitor	HP 0160-3724	0.47 μ F	A
Extender board	HP 5060-2043	24 pin	T
Extender board	HP 5060-1742	18 pin	T

* P = Performance Test; A = Adjustments; T = Troubleshooting

Table 1-2 Specifications

Frequency Characteristics

Waveforms: Sine, square, pulse, triangle, ramp.
Range: 0.001 Hz to 50.00 MHz (0.001 Hz to 19.99 MHz for 20 and 80% duty cycle/symmetry).
Accuracy, Stability and Resolution:

	Norm	Trig. Gate, Burst	
		f < 1 kHz	f ≥ 1 kHz
Accuracy	0.001%*	0.001%*	5%
Stability over 1 hour	± 1x10 ⁻⁶ *	± 1x10 ⁻⁶ *	± 5x10 ⁻⁴ **
Stability over 24 hours	± 1x10 ⁻⁶ *	± 1x10 ⁻⁶ *	± 1x10 ⁻³ **
Resolution (digits)	4	4	3

* Accuracy and stability can be improved by phase locking to an external frequency reference.

** After 15 minutes.

Jitter: ≤ 0.2% at 20/80% duty cycle/symmetry
 ≤ 0.1% (≥ 1 kHz)
 ≤ 0.02% (0.1 Hz – 999 Hz), further improvement at lower frequencies.

Output Characteristics

(50 Ω Source terminated by 50 Ω load unless stated otherwise)
Range: amplitude and offset independently variable within ± 10 V.
Source Impedance: selectable 50 Ω ± 1% or 1 kΩ ± 10%, in parallel with 50 pF.
Amplitude: 10.0 mV_{pp} to 10.0 V_{pp},
 2.00 V_{pp} to 20.0 V_{pp} (1 k Ω into 50 Ω).

Accuracy:	Sine	Square	Triangle (50%)	Ramp (20%, 80%)	Pulse (20%, 80%)
< 1 kHz	± 2%	± 2%	± 2%	± 2%	± 2%
1 kHz – 5 MHz	± 2%	± 2%	± 2%	± 5%	± 2%
5 MHz – 20 MHz	± 5%	± 5%	± 10%	± 10%	± 5%
20 MHz – 50 MHz	± 5%	± 5%	± 5% to -20%	-	-

Resolution: 3 digits.

Offset: 0 to ± 5.00 V,
 0 to ± 10.0 V (1 kΩ into 50 Ω).

Accuracy: ± (1% programmed value + 1% signal V_{pp} + 20 mV).

Resolution: 2 digits (10 to 99 mV), 3 digits (≥ 100 mV).

Baseline Drift (Trig, Gate and Burst modes): ≤ 5% of peak amplitude.

Sine Characteristics (Norm mode):

Harmonic Components: Up to 5 MHz, THD < 1% of fundamental. Above 5 MHz, all harmonics at least 30 dB below fundamental.

Spurious: all non-harmonically related outputs at least 40 dB below fundamental.

Triangle/Ramp Characteristics

Symmetry: 20, 50, 80% selectable.

Linearity: (10% to 90%): ± 1% (up to 5 MHz),
 ± 5% (above 5 MHz). cont'd.

Square/Pulse Characteristics:

Duty cycle: 20, 50, 80% selectable.
Transition times (10% to 90%): < 5 ns,
 < 7 ns (1 kΩ into 50 Ω).
Preshoot/Overshoot/Ringing: ± 5%,
 ± 10% (1 kΩ into 50 Ω).

Operating Modes

Norm: continuous waveform is generated, phase locked to an internal 10 MHz crystal reference.

VCO: external voltage (100 kHz max) from 10 mV to 10 V linearly sweeps 3 decades up to top of decade in which the 8165A frequency is set. Four bands limited to less than 3 decades:

- 100 mV – 10 V for 100 kHz – 10 MHz
 and 10 Hz – 1 kHz,
- 10 mV – 2 V for 100 kHz – 20 MHz,
- 50 mV – 5 V for 500 kHz – 50 MHz.

Trig: pos. ext input pulse ≥ 10 ns wide generates one output cycle. Upper level ≥ +250 mV, lower level ≤ 0V.

Gate: oscillator enabled when ext input ≥ +250 mV, disabled when ≤ 0 V. First and last output cycles are always complete.

Burst: a preprogrammed number of output cycles is generated. Min. time between bursts 50 ns. Burst length 0 to 9999 cycles. Min. trigger pulse width 10 ns, upper level ≥ + 250 mV, lower level ≤ 0 V.

FM: 0 to ± 1 V modulates 0 to ± 1% deviation.

Modulating Frequency: 100 Hz to 20 kHz (Norm mode), dc to 20 kHz (Gate mode with carrier frequency ≥ 1 kHz).

Input Impedance: 10 kΩ typical.

AM (Option 002 only): 0 to 2.5 V_{pp} modulates 0 to 100% modulation depth.

Modulating Frequency: dc to 10 MHz (-3 dB).

Input Impedance: 10 kΩ typical.

Pulse Modulation: transition times < 50 ns.

Envelope Distortion (dc to 250 kHz mod. freq.):

Carrier	Modulation	Distortion
≤ 1 MHz	0 to 90%	< 1%
> 1 MHz	0 to 30%	< 3%

Carrier Frequency Deviation: < 0.01%, 0 to 30% modulation.

Sweep (Option 002 only): provides logarithmic up/down sweep up to 3 decades between limits set on the 8165A. As in VCO mode, 4 bands limited to less than 3 decades. Min frequency 1 mHz.

Sweep-rate: 0.01, 0.1, 1, 10, 100, 1000 seconds per decade selectable.

Trigger: one up-down sweep per trigger pulse (upper level ≥ +250 mV, lower level ≤ 0 V, width ≥ 10 ns).

Accuracy: sweep start frequency ± (15% + 0.5% of max. stop frequency), sweep stop frequency ± 15%.

Resolution: 2 digits.

Table 1-2 Specifications (continued)

Auxiliary outputs and inputs

Ext. Input: external signals used in VCO, Trig, Gate, Burst and (Option 001) Sweep ext. trig.
Signal range in VCO: 10 mV to 10 V for 3-decade sweep.
Signal thresholds in Trig, Gate, Burst, Sweep ext trig: +250 mV (upper), 0 V (lower).
Max. input: ± 20 V,
Input impedance: 10 kΩ typical.

Sync. output: one trigger pulse per main output cycle.
Amplitude: 3 V_{pp} into open circuit (1.5 V_{pp} into 50 Ω).

Ext. 10 MHz ref.: external 10 MHz, TTL, system clock.
 Rear panel switch selects ext or int clock as instrument reference.

Mod Inp: FM and (Option 002 only) AM input.
Signal range in FM: 0 to ± 1 V for 0 to ± 1% deviation.
Signal range in AM: 0 to 2.5 V_{pp} for 0 to 100% modulation depth.
Max. input: ± 20 V.
Input impedance: 10 kΩ typical.

Sweep out (Option 002, only): triangular sweep voltage, 0 to 2.99 V amplitude for 3 decades (1 V/decade).

HP-IB capability and microprocessor

Code	Interface Function	Code	Interface Function
SH 1	Source Handshake	SR 1	Service Request
AH 1	Acceptor Handshake	RL 1	Remote/Local
T 6	Talker (basic talker, serial poll, unaddress to talk if addressed to listen)	PP 0	No Parallel Poll
L 4	Listener (Basic listener), unaddress to listen if addressed to talk)	DC 0	No Device Clear
		DT 1	Device Trigger
		C 0	No Controller
		E 1	Three-state Bus Drivers

Accuracy: See Frequency and Output Characteristics

Settling times:
Frequency: < 20 ms to ± 5% of programmed value. In Norm mode, and in Trig, Gate, Burst at frequencies < 1 kHz : < 70 ms to ± 2% of programmed value, < 300 ms to final value.
Other Functions: 20 ms. The following range changes can take up to 200 ms:
 Change of duty cycle.
 Selection to or from Sweep/VCO.
 Changing up to/down from the following decades:
 Frequency 1 kHz, 10 kHz, 100 kHz, 1 MHz, 20 MHz.
 Amplitude 100 mV, 1 V
 Offset 1 V.

Number of bytes sent/received
Listener: up to 65 bytes (89 in Option 002) for one complete set of operating parameters.
Talker-Learn Mode: 8 lines. Each line up to 16 bytes plus CR LF. Total: 144 bytes max.
Talker-Error Message: 1 byte.

Byte Rate:
Function Time (typical values): set up as talker/listener 1.1 ms, receiving time per character 0.1 ms, processing per parameter 3.0 ms, entry time per digit 2.0 ms, check time per parameter entry 5-10 ms, waveform/duty cycle/modulation 1.0 ms, input mode 6.5 ms, output modes 9.0 ms, recall 25 ms, store 380 ms.

Memory: 10 addressable locations plus one for existing operating state.
Capacity: each location can store a complete set of operating parameters and modes.
Access time: 20 ms each location.
Storage time: internal battery provides memory retention for approx. 4 weeks at room temperature. Battery re-charges when 8165A is switched on.

General

Power Requirements: 100 V, 120 V, 220 V or 240 V; +5 V to -10%, 48 to 66 Hz, 200 VA max.

Environmental: operates to specifications from 0 to 50°C, and with relative humidity to 95% at 40°C.
 Storage: -20 to +70°C.

Weight: net 12 kg (26.5 lbs.). Shipping 16 kg (35.3 lbs.).

Dimensions: 426 mm wide, 145 mm high, 450 mm deep (16.8 x 5.7 x 17.7 inches).

Accessories Available: The following cables for interconnecting HP-IB instruments to the bus are available:
 10631A 1 m (3.28 ft) 10631C 4 m (13.1 ft)
 10631B 2 m (6.56 ft) 10631D 0.5 m (1.64 ft)

The following adapters for connecting to the DUT are available:
 15104A Adder/Splitter
 15450A Adapter for terminating at DUT
 15451A TTL-CMOS Translator. CMOS level originates from DUT thus protecting it.

OPTIONS

- Option 002:** Sweep and Amplitude Modulation
- Option 907:** Front Handle Kit, p.n. 5061-0089
- Option 908:** Rack Mounting Kit, p.o. 5061-0077
- Option 909:** Combined Front Handle and Rack Mounting Kit, p.n. 5061-0083
- Option 910:** extra Operating and Service Manual

Specifications describe the instrument's warranted performance. Supplement characteristics - identified by the word "typical" - are intended to provide information useful in applying the instrument by giving typical, but non-warranted, performance parameters.

Data subject to change

SECTION II INSTALLATION

2-1 INTRODUCTION

2-2 This section provides installation instructions for the instrument and its accessories. It also includes information about initial inspection and damage claims, preparation for use, and packaging, storage and shipment.

2-3 INITIAL INSPECTION

2-4 Inspect the shipping container for damage. If the container or cushioning material is damaged, it should be kept until the contents of the shipment have been checked for completeness and the instrument has been checked mechanically and electrically. The contents of the shipment should be as shown in Figure 1-1 plus any accessories that were ordered with the instrument. Procedures for checking the electrical operation are given in Section 3. If the contents are incomplete, if there is mechanical damage or defect, or if the instrument does not pass the operator's checks, notify the nearest Hewlett-Packard office. Keep the shipping materials for carrier's inspection. The HP office will arrange for repair or replacement without waiting for settlement.

2-5 PREPARATION FOR USE

2-6 Power Requirements

2-7 The instrument requires a power source of 100V, 120V, 220V or 240V (+5%, -10%) at a frequency of 48 to 66 Hz single phase. The maximum power consumption is 200 VA.

2-8 Line Voltage Selection

CAUTION

BEFORE SWITCHING ON THIS INSTRUMENT make sure that the instrument is set to the local line voltage.

2-9 Figure 2-1 provides information for line voltage and fuse selection:

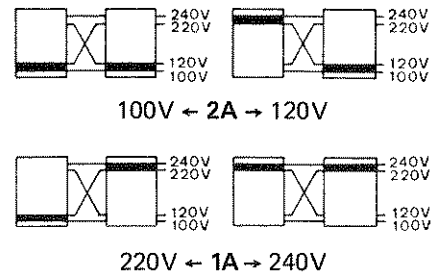

Figure 2-1. Switch Settings for the various Nominal Powerline Voltages

2-10 Power Cable

WARNING

To avoid the possibility of injury or death, the following precautions must be followed before the instrument is switched on:

- If this instrument is to be energized via an auto-transformer for voltage reduction, make sure that the common terminal is connected to the neutral pole of the power source (non-symmetrical supplies). Ensure that the ground connection is preserved).*
- The power cable plug shall only be inserted into a socket outlet provided with a protective ground contact. The protective action must not be negated by the use of an extension cord without a protective conductor.*
- Before switching on the instrument, the protective ground terminal of the instrument must be connected to a protective conductor of the power cable. This is verified by checking that the resistance between the instrument chassis and the front panel and the ground pin of the power cable plug is zero ohms.*

2-11 In accordance with international safety standards, this instrument is equipped with a three-wire power cable. When connected to an appropriate ac power receptacle,

this cable grounds the instrument cabinet. The type of power cable shipped with each instrument depends on the country of destination. Refer to Figure 2-2 for the part number of the power cords available.

2-12 If the plug on the cable supplied does not fit your power outlet, then cut the cable at the plug end and connect a suitable plug. The plug should meet local safety requirements and include the following features:

- Minimum current rating of 2A
- Ground connection
- Cable clamp.

The colour coding used in the cable will depend on the cable supplied (see Figure 2-2).

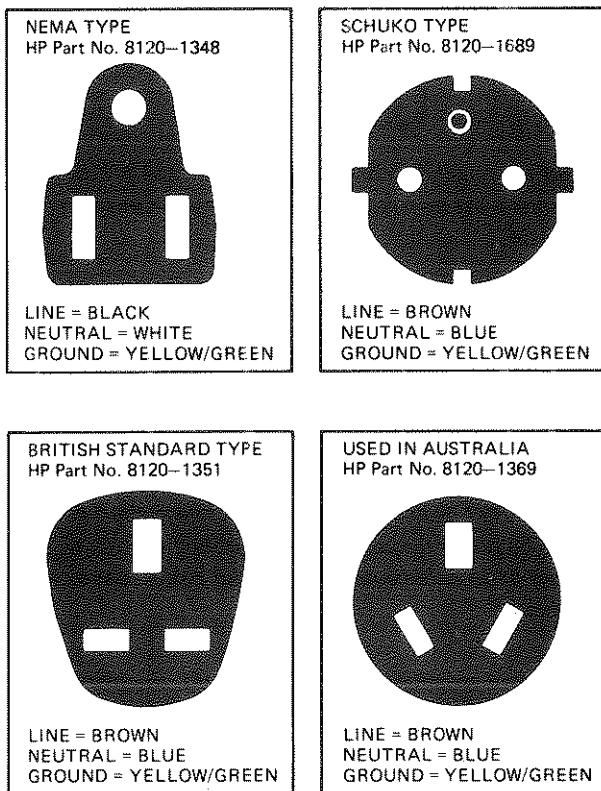

Figure 2-2. Power Cables Available: Plug Identification

2-13 HP-IB Connector

2-14 The rear panel HP-IB connector (Figure 2-3) is compatible with the connectors on Cable Assemblies 10631A, B, C and D. If a cable is to be locally-manufactured, use connector male, HP part number 1251-0293.

2-2

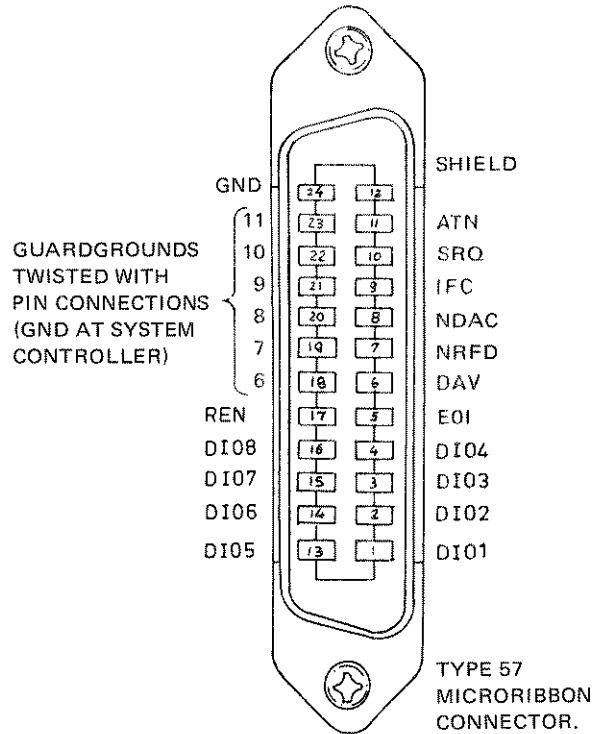

Figure 2-3. HP-IB Connector

2-15 HP-IB Logic Levels

2-16 The 8165A HP-IB lines use standard TTL logic. Logic levels are as follows:

- True = low = digital ground or 0V dc to +0.4V dc,
- False = high = open or +2.5V dc to +5V dc.

All HP-IB lines have LOW assertion ("1") states. High states are held at +3V dc by pullups within the instrument. When a line functions as an input, approximately 3.2mA of current is required to pull it low through a closure to digital ground. When a line functions as an output, it will sink up to 48mA in the low state and approximately 0.6mA in the high state.

CAUTION

Isolation. The HP-IB line screens are not isolated from outer chassis (frame) ground.

2-17 Operating Environment

2-18 The instrument will operate within specifications when the ambient temperature is between 0°C and 50°C.

SECTION III OPERATION AND PROGRAMMING

3-1 INTRODUCTION

3-2 This section explains the functions of controls, connectors and indicators, and provides operating and programming information. The sweep and AM option (002) is included.

3-3 SPECIAL OPERATING CONSIDERATIONS

3-4 The following steps must be taken before applying power to the Model 8165A.

- a) Read the safety summary at the front of this manual.
- b) Be sure the power selector switches are set properly for the power source being used to avoid instrument damage.
- c) Ensure load is not overdriven (up to 20 V p-p or 400 mA can be delivered).

CAUTION

Do not change the LINE SELECTOR Switch setting with the instrument on or with power connected to the rear panel.

3-5 OPERATORS CHECKS

3-6 Use the performance checks in Section IV to verify proper operation of the 8165A.

3-7 CONTROLS, CONNECTORS AND INDICATORS

3-8 Refer to Figure 3-1.

3-9 OPERATING INSTRUCTIONS

3-10 Operating modes and parameters can be set on the front panel (local operation) or programmed using the HP-IB. The operating modes, selected by pushbuttons with built-in indicators, are explained in the following paragraphs. Signal parameter selection, involving a 3-step operation (select PARAMETER, select DATA, ENTER units) and using a numerical display with a units indicator, is dealt with in § 3-45.

3-11 Commence by setting the LINE switch on and press the DISABLE/ENABLE button (the lamp should

go out, indicating that the output is enabled). The 8165A will have automatically assumed the operating state prevailing at switch-off (see also § 3-59). Should the ERROR lamp flash, an incompatible setting has been attempted and reference should be made to § 3-60.

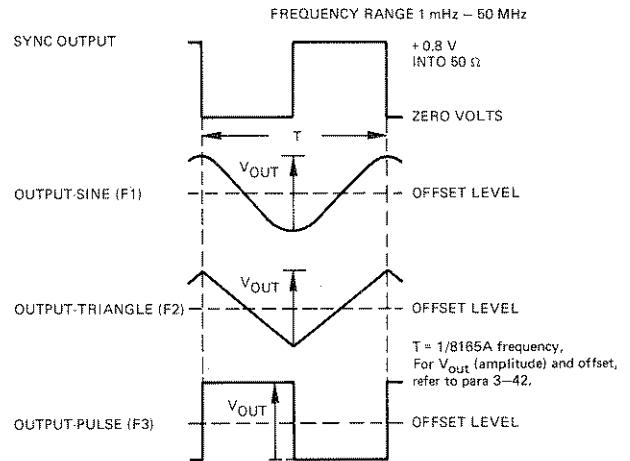

Figure 3-2 Normal Mode (50 % duty cycle/symmetry)

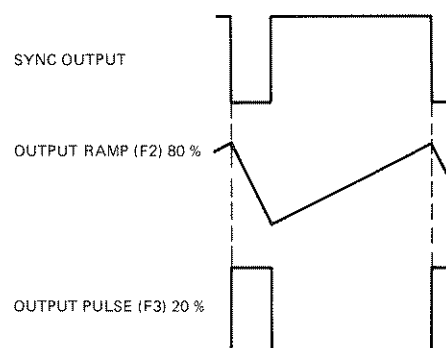
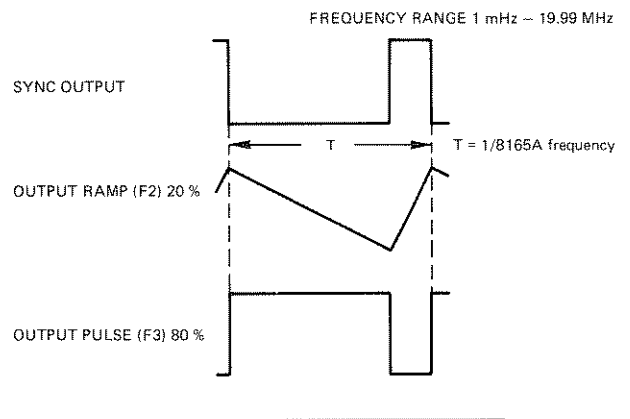

Figure 3-3 Normal Mode (20 and 80% duty cycle/symmetry)

3-12 Function and Duty cycle

3-13 As shown in Figures 3-2 and 3-3, triangular or square wave output with 20, 50 or 80% symmetry/duty cycle, or sine wave may be selected by pressing the appropriate FUNCTION and DUTY CYCLE buttons. The Figures, in which NORM input mode (§3-15) and NORM output (§ 3-44) are assumed, also shows the relationship between OUTPUT and SYNC OUTPUT.

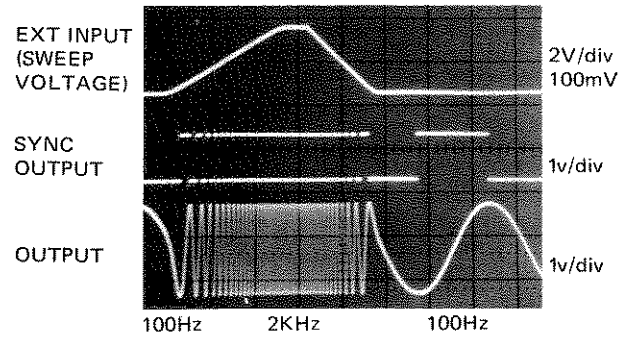

Figure 3-4. Example of operation in VCO mode

3-14 Input Modes (Note: frequency generation above and below 1kHz are dissimilar, see §3-37).

3-15 Normal Mode (NORM) (Figures 3-2, 3-3).

3-16 When normal mode is selected, the output is continuous and its frequency is determined by the FREQUENCY setting (§3-46).

3-17 Voltage-controlled Oscillator Mode (VCO)

3-18 In this mode, a signal applied to the EXT INPUT connector determines the output frequency. The applied signal may change at rates up to 100 kHz. The working

range of input voltage (10 mV – 10V) sweeps the output frequency over a maximum range of 1 : 1000; the actual range swept depends, as shown in Table 3-1, on the 8165A's frequency setting.

3-19 As an example, suppose a sweep from 50 Hz up to 500 Hz is required. This means that, when the 8165A is set to a frequency anywhere in the range 100 Hz – 999 Hz (which brackets the desired sweep maximum), the desired sweep can be obtained by applying an external signal which varies between + 500 mV and + 5 V levels. See Figure 3-5.

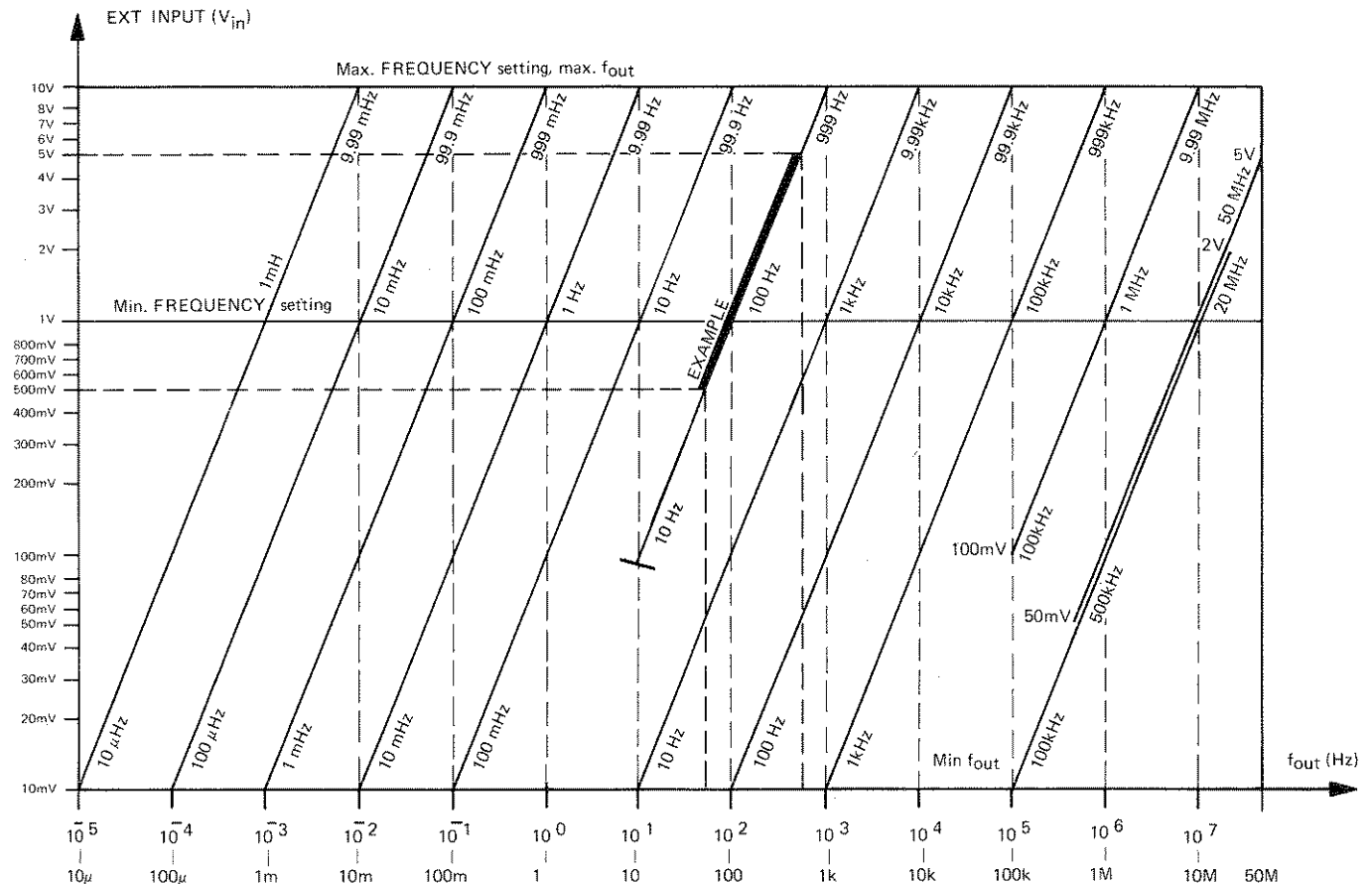

Figure 3-5 VCO mode characteristics

Table 3-1. Bands in VCO Mode

FREQUENCY setting of 8165A	Sweepable band			
	From		To	
	V _{in} min	f _{out} min	V _{in} max	f _{out} max
1 mHz - 9.99 mHz	10mV	10μHz	10V	10mHz
10 mHz - 99.9 mHz	10mV	100μHz	10V	100 mHz
100 mHz - 999 mHz	10mV	1mHz	10V	1Hz
1 Hz - 9.99 Hz	10mV	10mHz	10V	10Hz
10 Hz - 99.9 Hz	10mV	100mHz	10V	100Hz
100 Hz - 999 Hz	100mV	10 Hz	10V	1kHz
1 kHz - 9.99 kHz	10mV	10Hz	10V	10kHz
10 kHz - 99.9 kHz	10mV	100Hz	10V	100kHz
100 kHz - 999 kHz	10mV	1kHz	10V	1MHz
1 MHz - 9.99 MHz	100mV	100kHz	10V	10MHz
10 MHz - 19.99 MHz	10mV	100kHz	2V	20MHz
20 MHz - 50 MHz	50mV	500kHz	5V	50MHz

3-20 External Trigger Mode (TRIG)

3-21 When externally triggered, the positive-going edge of the pulse applied to the EXT INPUT connector initiates one complete output cycle (Figure 3-6), the frequency (and also the maximum trigger frequency) being defined by the 8165A's frequency setting. Thus, a pulse train of desired repetition rate and pulse width can be set up. By using different duty cycle settings a variety of waveform possibilities are realized (Figure 3-7). Triggering may also be done manually or by programming.

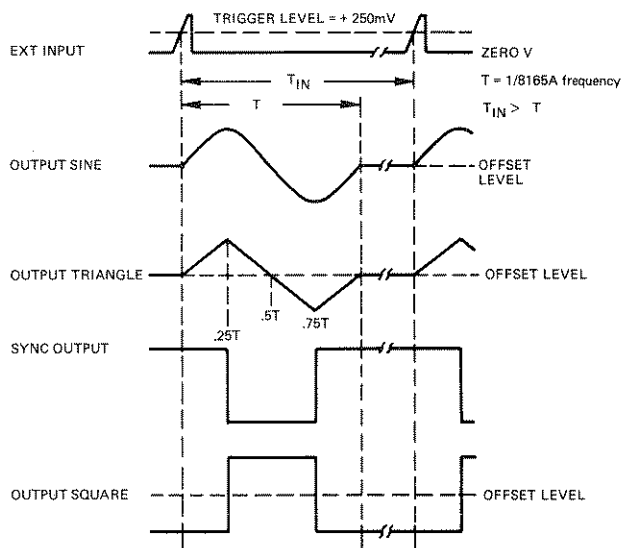

Figure 3-6 External Trigger Mode (50 % duty cycle/symmetry)

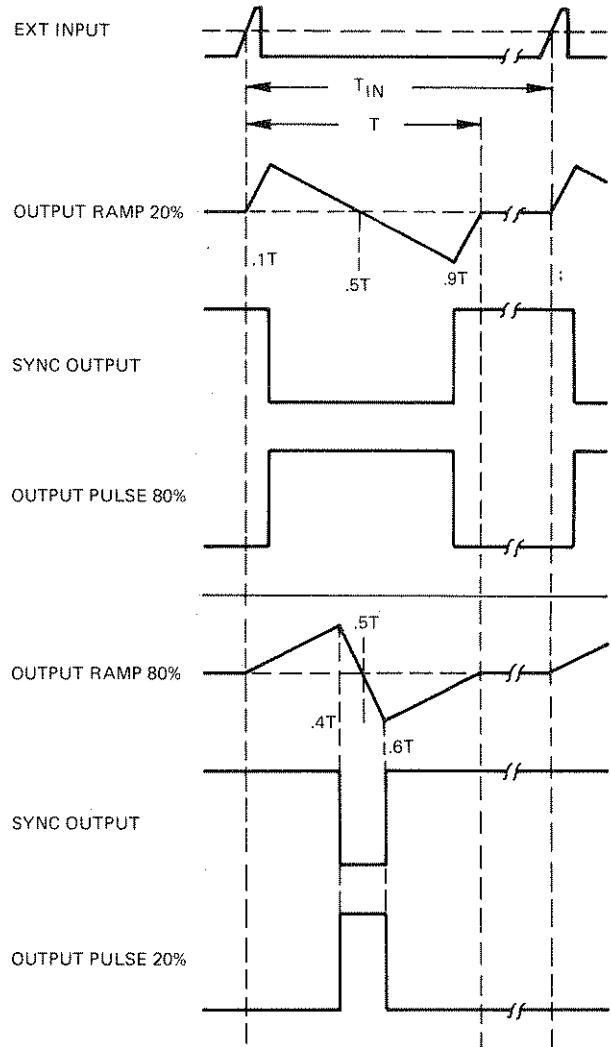

Figure 3-7. External Trigger Mode (20 and 80% duty cycle/symmetry)

3-22 Gate Mode (GATE)

3-23 In gate mode, the leading edge of a positive pulse applied to the EXT INPUT connector initiates the output stream, and the trailing edge causes the following

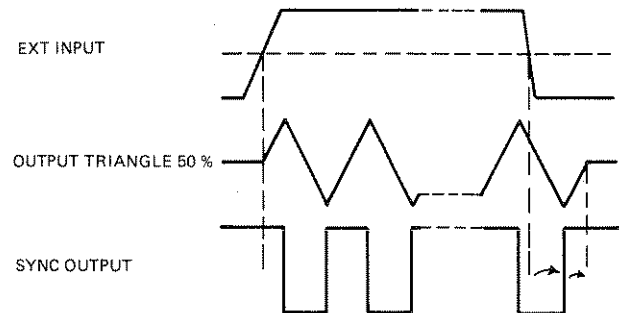

Figure 3-8. Example of Gate Mode

positive edge of the SYNC OUTPUT to terminate the stream at the next crossover. A whole number of complete output pulses are always generated.

3-24 Burst Mode (BURST)

3-25 A preset number of output cycles can be generated on each leading edge of a positive-going trigger pulse signal applied to EXT INPUT when burst mode is selected. The burst length may be set up to 9999 cycles as described in 53-50. At least 50 ns must separate consecutive bursts. Can be triggered manually.

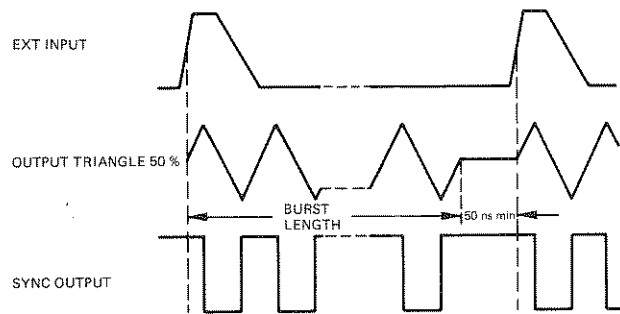

Figure 3-9. Example of Burst Mode

3-26 Sweep Modes – OPTION 002 Only

3-27 Internal Trigger Sweep selection will cause the output frequency to make one up/down sweep from the SWEEP START to the SWEEP STOP limits set on the 8165A (53-48). As shown in Table 3-2, the sweep takes place within a band whose top decade brackets the SWEEP STOP value. The internally-generated, triangular, sweep voltage V_{sweep} is available at the rear panel SWEEP OUT BNC. Frequency change rate is logarithmic.

Table 3-2. Bands in Sweep Mode

SWEEP START min		SWEEP STOP max	
f_{out}	V_{sweep}	f_{out}	V_{sweep}
1 mHz	2.0 V	9.9 mHz	2.99 V
1 mHz	1.0 V	99 mHz	2.99 V
1 mHz	0.0 V	.99 Hz	2.99 V
10 mHz	0.0 V	9.9 Hz	2.99 V
.10 Hz	0.0 V	99 Hz	2.99 V
10 Hz	1.0 V	.99 kHz	2.99 V
10 Hz	0.0 V	9.9 kHz	2.99 V
.10 kHz	0.0 V	99 kHz	2.99 V
1 kHz	0.0 V	.99 MHz	2.99 V
100 kHz	1.0 V	9.9 MHz	2.99 V
500 kHz	0.69 V	50 MHz	2.69 V

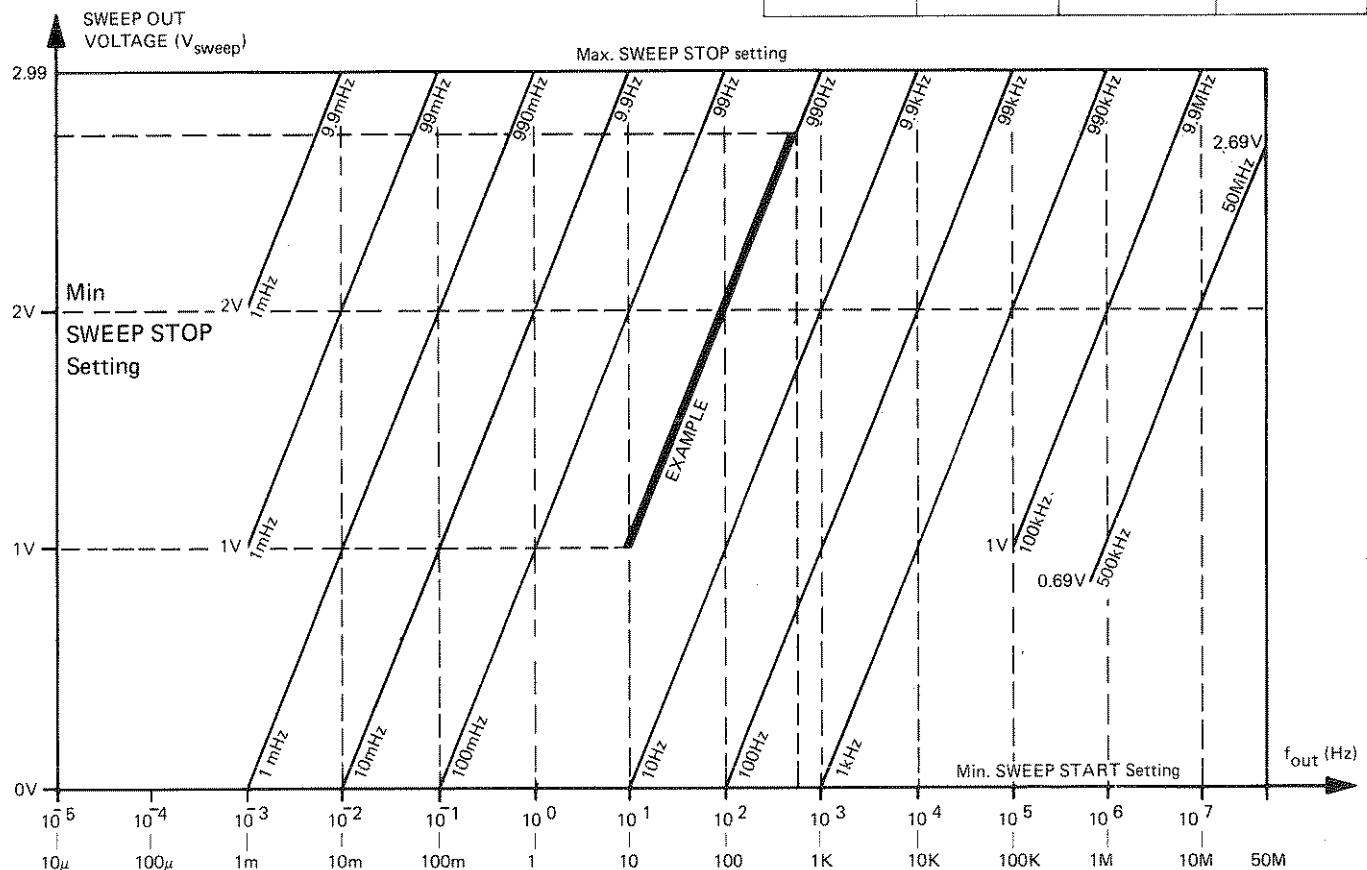

Figure 3-10. Sweep Mode Characteristics

3-28 As an example, suppose a sweep is required from 10 Hz (SWEEP START) to 700 Hz (SWEEP STOP), then V sweep varies between the levels 1.00 V (i.e., log 10) and 2.84 V (i.e., log 700).

3-29 Sweep times of 0.01, 0.1, 1, 10, 100, 1000 seconds per decade can be selected on the SWEEP TIME push-buttons.

3-30 External Trigger Sweep requires the application of a positive pulse at the EXT INPUT connector to initiate a single up/down sweep (Figure 3-11). In other respects, operation is the same as internal trigger sweep.

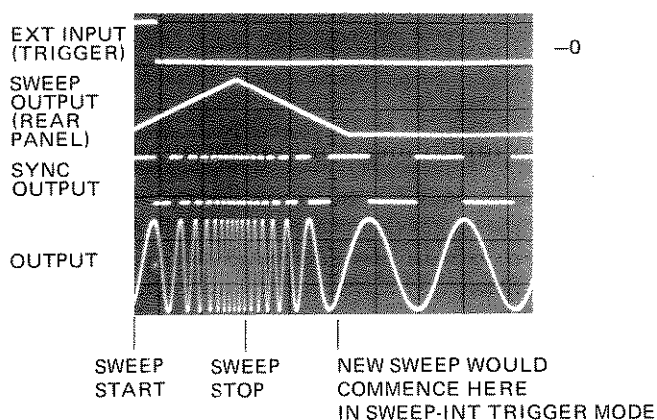

Figure 3-11. Example of Sweep Mode

3-31 Frequency Modulation (FM)

3-32 The 8165A's output can be frequency modulated by applying a voltage to the rear panel MOD INP connector. The maximum deviation is $\pm 1\%$ of carrier frequency for which an external voltage of ± 1 V is needed. In normal mode, the modulating voltage can vary in the range 100 Hz to 20 kHz. In trigger, gate or burst modes, the modulating frequency may be extended down to dc, but the 8165A's (carrier) frequency must be set to at least 1,000 kHz.

3-33 Amplitude Modulation (AM)

3-34 A signal can be applied to the rear panel MOD INP connector to provide a precisely amplitude-modulated signal at the 8165A output. Amplitude range for the modulating signal is 0–2.5 V_{pp} to provide a modulation range of 0–100%. Modulating frequency is dc to 100 MHz (-3 dB points).

3-35 Frequency Reference

3-36 Phase lock techniques, using an internal, precision 10 MHz crystal reference, achieve very stable output frequencies. A BNC and switch on the rear panel permit the use of an external, 10 MHz, TTL, system

master clock instead of the internal reference.

3-37 Frequency Generation

3-38 Because of the 8165A's wide frequency range, two methods of frequency generation are used. These lead to different distortion and stability considerations – but first, a brief description of the two methods.

3-39 The heart of the 8165A is a voltage-controlled, 1 kHz–50 MHz, oscillator which usually operates in phase lock using, as already mentioned, a crystal reference. For frequencies below 1 kHz, the output of the voltage-controlled oscillator is arranged to be an exact multiple of the required frequency, and a programmed divider reduces it to that needed. A triangular waveform is approximated by means of an up/down counter (programmed for 20, 50, or 80% duty cycle) and a D/A converter. (Sinewave is derived from the 50% duty cycle triangle using the same sine shaper as is used for frequencies above 1 kHz; square wave is derived by detecting the highest and lowest count of the up/down counter.) The D/A converter output consists of 1000 amplitude steps per output cycle; this means that, at 1 MHz for example, the amplitude changes from one discrete level to the next every second.

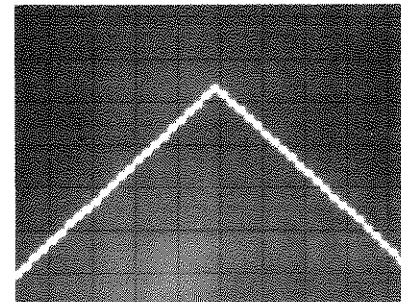

10 ms/div, 10 mV/div
8165A: 50Hz, triangle, 1 V.

Figure 3-12. Example of Triangle Output below 1 kHz

3-40 Differences in operation can now be summarized as follows:

- frequencies below 1 kHz
 - amplitude steps through 1000 discrete levels per cycle,
 - phase lock in all modes,
- frequencies above 1 kHz
 - amplitude continuous,
 - phase lock in normal mode only.

3-41 Output Parameters

3-42 The 8165A is designed so that source/load configurations of 50Ω into 50Ω , 50Ω into high impedance, and $1\text{ k}\Omega$ into 50Ω can be easily arranged.

Amplitude and offset are independently variable and depend upon the source/load configuration (Table 3-3). As shown in Figure 3-13, reflections are minimized when the system is terminated by a low-capacitance 50Ω-load at the device which the 8165A drives. However, termination at the 8165A may be preferred if the device impedance is reactive.

20 V AMPLITUDE CAPABILITY
OUTPUT MODE 50Ω, LOAD IMPEDANCE 1KΩ

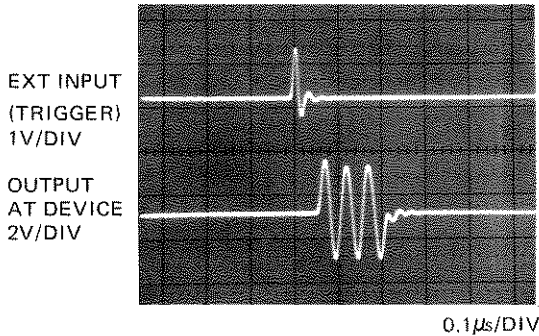

20 V AMPLITUDE CAPABILITY
OUTPUT MODE 1KΩ, LOAD IMPEDANCE 50Ω

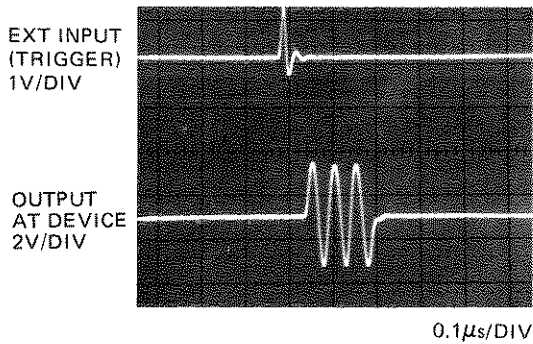

10 V AMPLITUDE CAPABILITY
OUTPUT MODE 50Ω, LOAD IMPEDANCE 50Ω

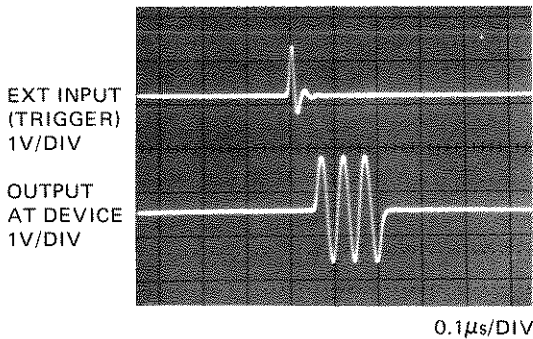

8165A SETTINGS: SINE, BURST (3 CYCLES), 20 MHz,
AMPLITUDE 2.5V (DIGITAL DISPLAY), ZERO OFFSET

Figure 3-13. Source/load configurations (Low-capacitance load)

Table 3-3 Output Voltage Summary

OUTPUT MODE	EXT LOAD	AMPLITUDE ¹ V _{pp}		OFFSET ¹ V _{dc}		VOLTAGE AT EXT LOAD V _{pp} /V _{dc}
		MIN	MAX	MIN	MAX	
50Ω ²	50Ω	10mV	10V	0±10mV	±5V	As digital display
50Ω ²	HIGH Z	20mV	20V	0±20mV	±10V	Approx 2x digital display
1kΩ ³	50Ω	2V	20V	0±20mV	±10V	As digital display

Notes

1. Amplitude + offset must lie within a ± 10 V window. Voltages set as in §3-52.
 2. Applies only to displayed amplitudes ≤ 10V_{pp}
 3. Applies only to displayed amplitudes ≥ 2V_{pp}
- Attempts to select incompatible impedance/voltage configurations will not be accepted and will cause the ERROR lamp to light.

3-43 In addition to 50 Ω systems, the instrument is also suitable for driving any desired impedance. This is due to the current mode output configuration (Figure 3-14) where the maximum current available with 1 kΩ source impedance is ± 200mA peak signal and ± 200mA offset.

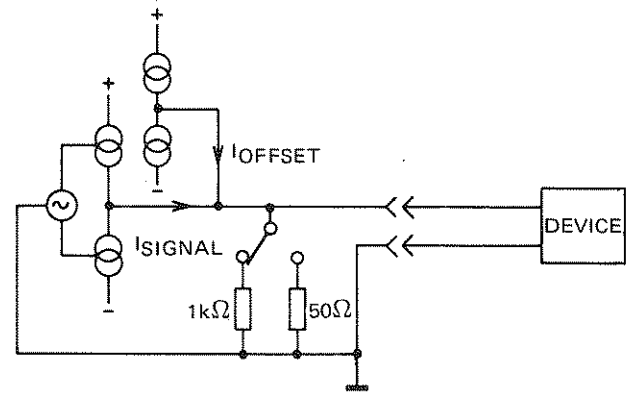

Figure 3-14. Configuration of Output Stage

3-44 The output can be turned on and off with the DISABLE/ENABLE button and may be inverted using the INV/NORM button. The OUTPUT MODE buttons are respectively lit when disable, invert and 1 kΩ are effective. Disable is automatic at switch-on. For threshold testing, the offset can be obtained without signal by selecting trigger, gate or burst modes in the absence of a trigger signal.

3-45 Selection and Storage of Parameters

3-46 Frequency

- 3-47 The 8165A's frequency is set as follows:
- press FRQ key, check that FREQUENCY lamp blinks,
 - press the required DATA keys sequentially (e.g., 4 then 3, then 2, then ., then 6) and observe that the display above the FREQUENCY lamp displays the desired number,
 - press the appropriate ENTRY key for the unit desired (e.g., "Hz or V") verify that the correct unit appears to the right of the FREQUENCY display and that the lamp glows steadily. The 8165A is now operating at the new frequency (432.6 Hz, in this example).

Use may be made of the VERNIER controls as follows:

- press FRQ key,
- press the appropriate VERNIER key for fast or slow, up or down shift. The output frequency changes with the display during this process so that it is only necessary to press an ENTRY key if the unit is to be changed.

When setting frequency for the VCO mode, refer to Table 3-1.

3-48 Sweep Start/Stop (Option 002 only)

- 3-49 When sweep mode is required, set the start and stop frequencies using procedures similar to §3-45 in conjunction with the SWEEP START and SWEEP STOP keys. Refer to Table 3-2 for the permissible bands.

3-50 Burst

- 3-51 The number of cycles per burst is set as follows:
- press PARAMETER key BURST, check that BURST lamp blinks,
 - press the desired DATA keys, check that the required number shows in the display above the BURST lamp,
 - press the ENTRY key "kHz or BURST".

3-52 Amplitude and Offset

- 3-53 Amplitude and offset are each set in a manner similar to frequency, using the AMPL and OFFSET keys.

If a negative offset is required, press the CHS (change sign) key any time during DATA entry but before pressing the mV or V key.

3-54 Storage and Recall

- 3-55 Ten addressable store locations are available, each of which is capable of storing a complete set of 8165A operating modes and parameters. To store a current set of modes and parameters:

- press STO (store) key,
- press a DATA key (0 to 9, as desired).

To put the 8165A into a previously-stored set of operating modes and parameters:

- press RCL (recall) key
- press the required DATA key (0 to 9).

3-56 Power-fail Memory

- 3-57 When power is removed from the 8165A, the current operating parameters are automatically stored in the power-fail memory so that, when the supply is restored, the 8165A can return to its previous operating state. However, to protect external circuits and prevent possible remote control ambiguities:

- the output is disabled,
- local control is implemented.

Consequently, deliberate (manual or programmed) intervention is required to obtain an output or to acquire remote control.

3-58 Storage and Access Times

- 3-59 Addressable memories and the power-fail memory remain effective for approx 4 weeks at room temperature after power has been removed. Access time is 20ms, see Table 1-2 for settling times.

Note: If the internal batteries are allowed to run down, data must be re-entered and the instrument should be left switched on so that the batteries can recharge.

3-60 Error Indication

- 3-61 If it is attempted to select incompatible operating modes or parameters, the ERROR lamp will flash and the 8165A will remain in its previous operating state. To clear an error, correct DATA and ENTRY. Common causes of errors are:

- frequency out of range,
- duty cycle/frequency,
- output impedance/voltage (see §3-41).

3-62 PROGRAMMING INSTRUCTIONS

3-63 The 8165A operates on the HP-IB as follows:
listens to messages from the HP-IB system controller by means of which all* 8165A operating parameters and modes can be programmed; access time (the time between program command and the implementation at the 8165A output, refer also to specifications, Table 1-2) is 20 ms,
**vernier operation is simulated by programming a loop which increments/decrements a value.*
talks; provides error messages and reports operating state.

3-64 The bus lines are as follows (all use negative logic):
8-bit data bus (lines DIO 1 to 8),
handshake lines – DAV (data valid), NRFD (not ready for data), NDAC (data not accepted),
control lines – IFC (interface clear), ATN (attention), SRQ (service request), REN (remote enable), EOI (end or identify).

The 8165A uses all lines except EOI. Terminations, logic levels and pinouts are described in Section II. In this manual, bus information will generally be restricted to 8165A specifics, for this reason, the handshake lines will not be discussed and the control lines will only be mentioned in connection with specific 8165A activity.
 Permissible codes are presented in Table 3-8. For more bus information, refer to the condensed description in HP publication 59401-90030 and to IEEE Standard 488.

3-65 To use the 8165A on the bus, remote control must be implemented. This is done by setting the REN line true. A return to local control can be made manually (LOCAL RESET button), by sending the command GTL (go to local), or by setting REN false. Refer to 53-73.

3-66 Addressing

3-67 Talk and listen addresses are transmitted by the system controller over the data bus with the ATN line true. When an instrument recognizes its address, it will adopt the appropriate bus mode (i.e., it will listen to the bus if its listen address has been transmitted, talk if the talk address has been transmitted). The 8165A's addresses are selected by a switch on the rear panel from the possibilities presented in Table 3-4. When allocating addresses, make sure no two instruments have the same address.

3-8

When programming an address, set ATN true and arrange that the ASCII character derived from Table 3-4 appears on the bus. To deaddress, use UNL, UNT commands (or address another device as talker).

Table 3-4 Available Addresses (ATN true)

Data bus (DIO lines)		Address in ASCII		
Fixed	Selectable	Talk	Listen	
8 7 6	5 4 3 2 1			
0 T L	0 0 0 0 0	@	Space	
0 T L	0 0 0 0 1	A	!	
0 T L	0 0 0 1 0	B	"	
0 T L	0 0 0 1 1	C	#	
0 T L	0 0 1 0 0	D	\$	
0 T L	0 0 1 0 1	E	%	
0 T L	0 0 1 1 0	F	&	
0 T L	0 0 1 1 1	G	'	
0 T L	0 1 0 0 0	H	(
0 T L	0 1 0 0 1	I)	
0 T L	0 1 0 1 0	J	*	
0 T L	0 1 0 1 1	K	+	
0 T L	0 1 1 0 0	L	,	
0 T L	0 1 1 0 1	M	-	
0 T L	0 1 1 1 0	N	.	
0 T L	0 1 1 1 1	O	/	
0 T L	1 0 0 0 0	P	0	8165A set to this address at factory.
0 T L	1 0 0 0 1	Q	1	
0 T L	1 0 0 1 0	R	2	
0 T L	1 0 0 1 1	S	3	
0 T L	1 0 1 0 0	T	4	
0 T L	1 0 1 0 1	U	5	Usually controller address!
0 T L	1 0 1 1 0	V	6	
0 T L	1 0 1 1 1	W	7	
0 T L	1 1 0 0 0	X	8	
0 T L	1 1 0 0 1	Y	9	
0 T L	1 1 0 1 0	Z	:	
0 T L	1 1 0 1 1	[;	
0 T L	1 1 1 0 0	\	<	
0 T L	1 1 1 0 1]	=	
0 T L	1 1 1 1 0	^	>	
0 T L	1 1 1 1 1	_	?	Forbidden setting! UNT, UNL commands.

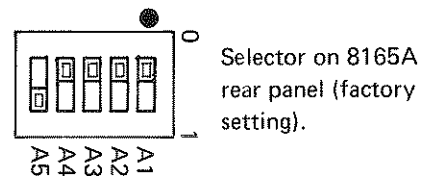

L = 1 for listen address, 0 for talk address
 T = 1 for talk address, 0 for listen address

3-68 Mode and Parameter Setting

3-69 When the 8165A has been listen-addressed, it will be prepared to accept messages which will change a parameter or its operating mode. Each mode and parameter-setting message consists of a number of ASCII data bytes transmitted serially over the data lines with

ATN false. The coding for the bytes is given on the front panel and also shown in Table 3-5 which summarizes all mode and parameter-setting messages, and provides an example. Reference may be made to Table 3-8 to convert each ASCII byte to a bit pattern on the data bus.

Table 3-5 Mode and Parameter-setting Messages (ATN false)

Message	Serial ASCII bytes	Comments
Function		
select sine	F1	
select triangle	F2	
select square	F3	
Duty cycle:		
select 20%	D1	See §3-76
select 50%	D2	
select 80%	D3	
Input mode:		
select normal	I1	
select VCO	I2	
select trigger	I3	Trigger message (Table 3-6) can be used.
select gate	I4	
select burst	I5	Trigger message (Table 3-6) can be used.
select ext trig sweep	I6	Option 002 only.
select int trig sweep	I7	Option 002 only.
Modulation:		
select FM	FM1	
reject FM	FM ϕ	
select AM	AM1	} AM Option 002 only
reject AM	AM ϕ	
Parameters:		
set frequency to f MHz	FRQ/MZ	f a number 1-9999
set frequency to f Hz	FRQ/HZ	f a number 0.001-9999
set frequency to f kHz	FRQ/KHZ	f a number 0.001-9999
set frequency to f MHz	FRQ/MHZ	f a number 0.001-50 (50% duty cycle), 0.001-19.99 (20,80%).
set amplitude to v mV	AMPvMV	v a number 10/20-999
set amplitude to v V	AMPvV	v a number 0.01 = 10/20
set offset to v mV *	OFSvMV	v a number $\pm 10/20 - \pm 5/10$
set offset to v V *	OFSvV	v a number $\pm 0.01 - \pm 5/10$
<i>*If no sign is given, the previous sign is assumed.</i>		} see §3-42.
set burst to n cycles	BURnBT	
set sweep start to f MHz	STAfMZ	} Option 002 only, for f refer to §3-26.
set sweep start to f Hz	STAfHZ	
set sweep start to f kHz	STAfKHZ	
set sweep start to f MHz	STAfMHZ	
set sweep stop to f MHz	STPfMZ	
set sweep stop to f Hz	STPfHZ	
set sweep stop to f kHz	STPfKHZ	
set sweep stop to f MHz	STPfMHZ	

Table 3-5 (cont'd)

Message	Serial ASCII bytes	Comments
Sweep time: select 0.01s/decade select 0.1s/decade select 1 s/decade select 10s/decade select 100 s/decade select 1000s/decade	S1 S2 S3 S4 S5 S6	} Option 002 only
Output mode: disable output enable output invert input normal output select 1 kΩ output imped. select 50 Ω output imped.	OD OE OI ON O1 O5	
Memory: store current operating modes and parameters in 8165A store location n adopt parameters in store location n	STOn RCLn	} n an integer 0-9, see § 3-54

Example: a serial byte transmission

F2 D1 I4 FRQ99.9MZ AMP1.3V OFS-20MV OE OI O5 STO2

sets a listen-addressed 8165A to the following parameters: triangle, 20% duty cycle, gate mode, 99.9mHz, 1.3V amplitude, -20mV offset, output enabled, output inverted, 50 Ω output impedance. This entire set of parameters is then stored in the 8165A's memory location 2.

Example using Model 9825A Desktop Computer:

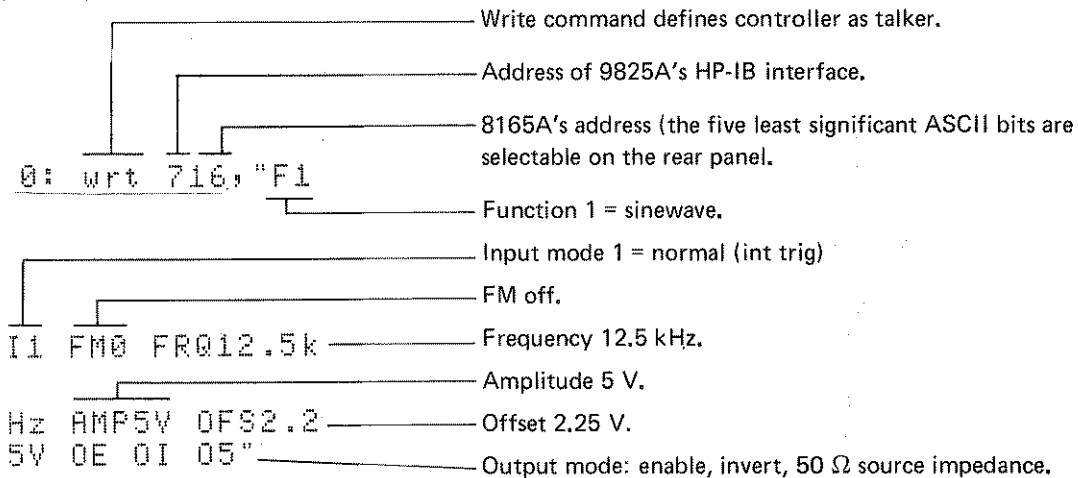

Notes

- Lower-case (small) letters may replace any or all of the ASCII capitals.
- Separators (i.e. space or comma) should be inserted between messages as shown in the above example
- In sweep mode, a separator must be inserted after a 'set sweep start' or 'set sweep stop' message.
- Omission of a separator may cause malfunction in error reporting (§ 3-77).
- The order in which parameters are programmed is not significant.

3-70 Control Messages and Commands (Table 3-6)

3-71 Programmed trigger

3-72 When the 8165A is in trigger or burst modes, a trigger message (GET) will initiate a single cycle or a burst. Example using HP 9825A Desktop Computer: trg 716.

3-73 Local, Remote and Local Lockout

3-74 When in remote, the 8165A's LOCAL RESET button can be inhibited by the local lockout command. To cancel local lockout, send GTL (go to local) or set the REN line false (or, the 8165A may be switched off, and on again at the LINE switch). The 9825A's GTL command is programmed by: lcl 7.

3-75 Learn Mode

3-76 When the 8165A is addressed as a talker subsequent to receiving the message 'SET', the 8165A will output its current operating parameters to the bus (same coding as in Table 3-5). The message 'SETn' accesses addressable memory n. In neither case are the store contents changed in any way. The parameters are transmitted in 8 strings, as follows:

- String 1 — function, duty cycle, input mode, FM status, AM status.
 - String 2 — sweep time, output status, output norm/comp, output 50 Ω/1 kΩ.
 - String 3 — frequency.
 - String 4 — amplitude.
 - String 5 — offset.
 - String 6 — burst.
 - String 7 — sweep start
 - String 8 — sweep stop
- } Standard 8165A transmits CR/LF

Each string has up to 16 characters and is terminated by CR/LF. Note that, in pulse operation, the learn mode duty cycle message is changed. Use the following table to check the interpretation:

	Program (Listen)	Learn (Talk)
Duty cycle (Square/pulse)		
20 %	D1	D3
50 %	D2	D2
80 %	D3	D1
Symmetry (Triangle/tramp)		
20 %	D1	D1
50 %	D2	D2
80 %	D3	D3

Example using the HP 9825A Desktop Computer:

```
0: dim A$(0,20) — Array dimensioned.
1: wrt 716:"SET: — Request for current parameters.
2: red 716,A$(1) — Talk address. 9825A reads first string.
3: end
*2742
```

F1 D2 I6 FM0 AM0 —9825A prints first string.

Step 2 is repeated for other strings (A\$ [x]) as required.

3-77 Error Reporting

3-78 In the event of a program attempting to put the 8165A into an error condition, the 8165A will remain in its previous operating condition and make a service request (sets SRQ line true). Under these circumstances, when addressed as a talker for purposes of a serial poll (i.e. SPE command sent from system controller), the 8165A puts an error message on the data bus. This message consists of a single byte in which bit 7 is set true when the 8165A has set the SRQ line true, and bits 1 to 4 comprise an error code (Table 3-7). See step 6 of Figure 3-16 overleaf.

Table 3-7. Error Messages

Data bus DIO lines	Message
8 7 6 5 4 3 2 1	
0 1 0 0 1 0 0 0	Amplitude out of range
0 1 0 0 1 0 0 1	Offset out of range
0 1 0 0 1 0 1 0	Frequency out of range
0 1 0 0 1 0 1 1	Output impedance error
0 1 0 0 1 1 0 0	Duty cycle/frequency incompatible
0 1 0 0 1 1 0 1	Sweep start/stop incompatible
0 1 0 0 1 1 1 0	Sweep out of range
0 1 0 0 1 1 1 1	Syntax error

Table 3-6. Control Messages and Commands

Message/Command	8165A Status	Bus data (ASCII)	9825A program example	Comments
Remote control	Local Listen/talk	Listen/talk address	rem 716	REN line true
Go to local	Listen Local	[SOH] *	lcl 716	ATN line true
Local lockout (LLO)	Listen	[DC1] *	llo 7	ATN line true
Give current operating parameters	Listen Talk	SET: As Table 3-5	wrt 716, "SET:"	
Give parameter set in location <i>n</i>	Listen Talk	SET <i>n</i> As Table 3-5	wrt 716, "SET <i>n</i> "	<i>n</i> is an integer 0-9
Trigger (GET)	Listen	[BS] *	trg.716	
Serial poll (SPE)	Any Talk	[CAN] * Error message (Table 3-7)	rds 716	with SRQ true DIO 7 true if 8165A has set SRQ true.

[] * = Single ASCII character. Do *not* program the individual characters within the brackets.

3-79 Program Example

3-80 The flow chart in Figure 3-15 illustrates typical 8165A bus activity when used with a computing controller. An imaginary situation has been chosen in which sequential operation at ten harmonically-related frequencies is required, each frequency being active for a duration of one second. The frequencies (as, indeed, all other operating modes and parameters) are stored in the 8165A's memory, counter loops being employed to generate location address and frequencies. A programmed loop reads the 8165A status and prints a report in the event of an error.

3-81 A possible way of implementing the flow chart using the Model 9825A Desktop Computer with HP-IB

interface 98034A is shown in the program example of Figure 3-16. In this example, the 98034A's address is assumed to be 7, thus the address of an instrument on the HP-IB is 7XX where XX is the *decimal* equivalent of the five least significant bits of the bus address. As an 8165A address selector setting of 10000 (Table 3-4) is assumed, for which the decimal equivalent is 16, the 8165A's address for purposes of programming with the 9825A is 716. Talk or listen addresses (more specifically, bits 6 and 7 of the HP-IB address) are automatically specified by the kind of statement governing the 9825A's activity, e.g., the statement rds 716 tells the 9825A to read from the bus and tells the 8165A to talk (talk address 16, ASCII P); the statement wrt 716 tells the 9825A to output to the bus and tells the 8165A to listen (listen address 16, ASCII zero).

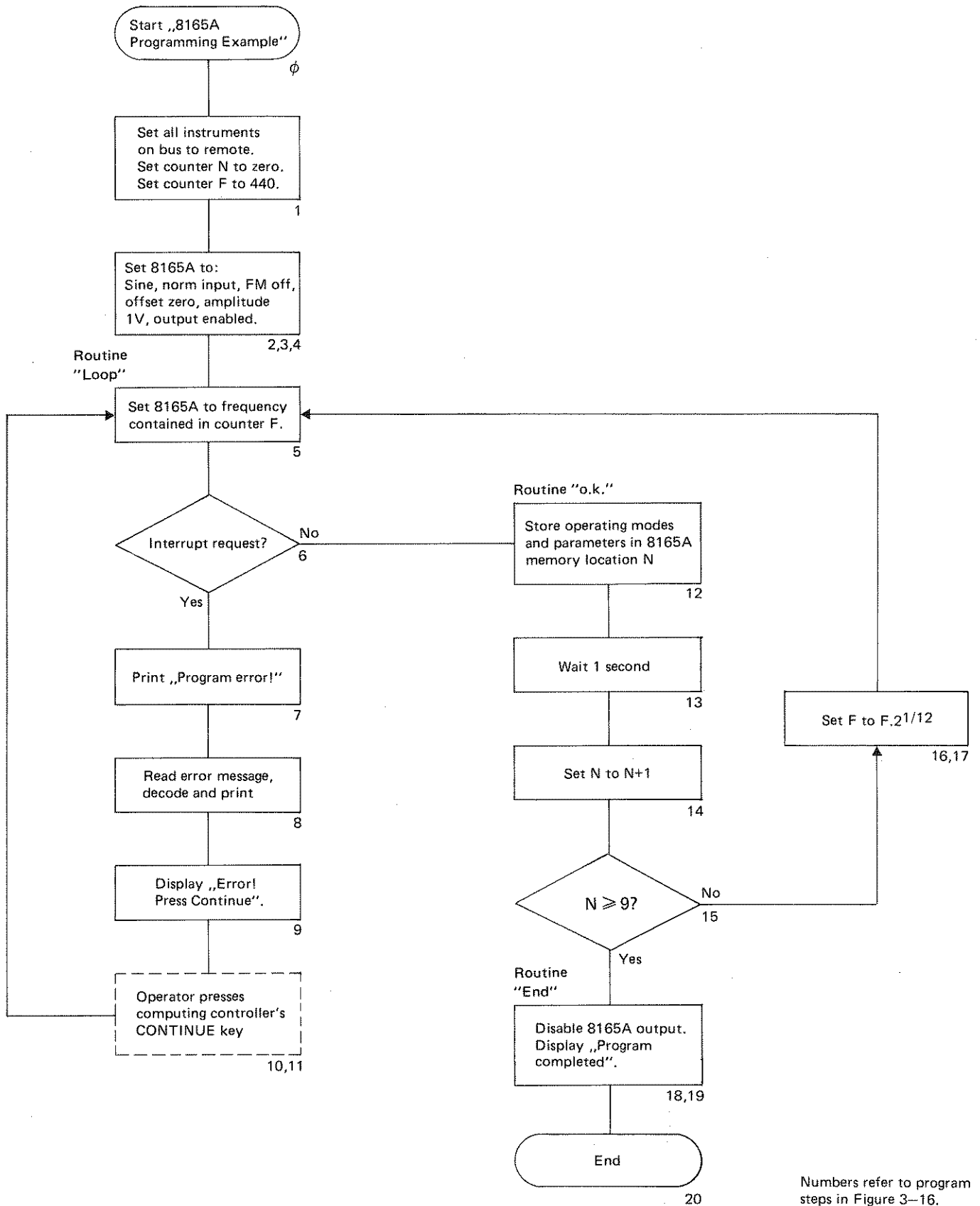

Numbers refer to program steps in Figure 3-16.

Figure 3-15. Illustrative Flow Chart

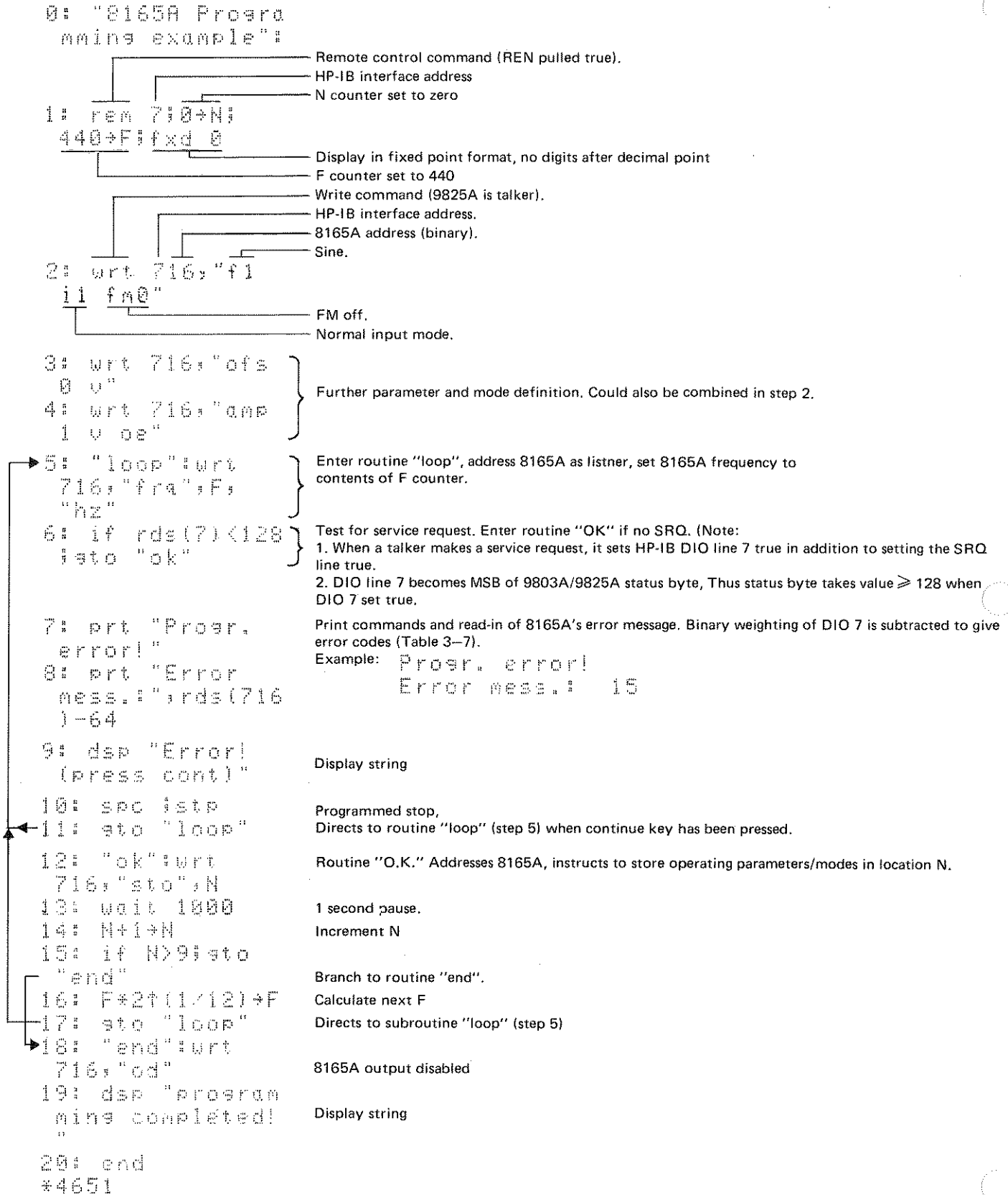

Figure 3-16. Program Example

Table 3-8. HP-IB Code Assignments (ASCII) for the 8165A

APPLIES ONLY IN COMMAND MODE (ATN TRUE)
 THESE CHARACTERS CAUSE SRQ
 THESE CHARACTERS ARE IGNORED

HP-IB DATA LINES					7	6	5	4	3	2	1	0	0	0	0	0	1	0	1	0	1	0	1	0	1	1	1		
					0	0	0	0	0	0	0	0	0	0	0	0	0	0	0	0	0	0	0	0	0	0	0	0	
					0	0	0	1	1	1	1	1	1	1	1	1	1	1	1	1	1	1	1	1	1	1	1	1	
0	0	0	0	0	0	NUL							DLE																
0	0	0	1	1	1	SOH	GTL						DC1	LLO	T														
0	0	1	0	2	2	STX							DC2		"														
0	0	1	1	3	3	ETX							DC3		#														
0	1	0	0	4	4	EGT							DC4		\$														
0	1	0	1	5	5	ENQ							NAK		%														
0	1	1	0	6	6	ACK							SYN		&														
0	1	1	1	7	7	BEL							ETB		'														
1	0	0	0	8	8	BS	GET						CAN	SPE	(
1	0	0	1	9	9	HT							EM	SPD)														
1	0	1	0	10	10	LF							SUB		*														
1	0	1	1	11	11	VT							ESC		+														
1	1	0	0	12	12	FF							FS		,														
1	1	0	1	13	13	CR							GS		-														
1	1	1	0	14	14	SO							RS		.														
1	1	1	1	15	15	SI							US		/														

↑ ASSIGNED LISTEN ADDRESS ↑ ASSIGN LISTEN ADDRESS ↑ ASSIGNED TALK ADDRESS ↑ ASSIGNED TALK ADDRESS

SAME INTERPRETATION (between columns 10 and 11)
 SAME INTERPRETATION (between columns 12 and 13)

SECTION IV PERFORMANCE TESTS

4-1 INTRODUCTION

4-2 The procedures in this section test the electrical performance of the instrument using the specifications of Table 1-2 as performance standards. All tests can be performed without access to the interior of the instrument.

4-3 EQUIPMENT REQUIRED

4-4 Equipment required for the performance tests is listed in Table 1-1, Recommended Test Equipment. Any equipment that satisfies the critical specifications given in the table may be substituted for the recommended model(s).

4-5 TEST RECORD

4-6 Results of the performance tests may be tabulated on the Test Record at the end of the test procedures. The Test Record lists all of the tested specifications and their acceptable limits. Test results recorded at incoming

inspection can be used for comparison in periodic maintenance, troubleshooting, and after repairs or adjustments.

4-7 PERFORMANCE TESTS

4-8 The performance tests given in this section are suitable for incoming inspection, troubleshooting, or preventive maintenance. During any performance test, all shields and connecting hardware must be in place. The tests are designed to verify the published instrument specifications, perform the tests in the order given and record the data on the test card and/or in the data spaces provided at the end of each procedure.

4-9 Each test is arranged so that the specification is written as it appears in Table 1-2. Next, a description of the test and any special instructions or problem areas are included. Each test that requires test equipment has a setup drawing and a list of the required equipment. The initial steps of each procedure give control settings required for that particular test.

PERFORMANCE TESTS

4-10 FREQUENCY

SPECIFICATION

1.000 mHz to 50.00 MHz (1.000 mHz to 19.99 MHz for 20 % and 80 % duty cycle/symmetry).
 Accuracy in NORM input mode: 0.001 %.

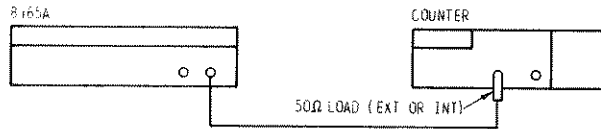

Figure 4-1. Test Setup for Frequency and Burst

EQUIPMENT

- Counter
- Cable Assembly BNC (61 cm)
- Feedthrough Termination 50 Ω (if necessary).

PROCEDURE

1. Connect equipment as shown in Figure 4-1
2. Set 8165A as follows:

INPUT MODE	NORM
FUNCTION	SQUARE
DUTY CYCLE	50%
FM	OFF
AMPL	1 V
OFFSET	0 V
OUTPUT MODE	ENABLE
	NORM
	50 Ω

3. Set counter to frequency measurement.
4. Set 8165A frequency and verify counter frequency reading as follows:

8165A setting	Counter reading
50.0 MHz	50.0000 MHz ± 500 Hz
10.0 MHz	10.0000 MHz ± 100 Hz
10.0 kHz	10.0000 kHz ± 0.1 Hz
1.00 kHz	1.00000 kHz ± 0.01 Hz

5. Set 8165A frequency and verify counter period reading as follows:

8165A setting	Counter reading
1.00 Hz	1.00000 s ± 10 μs
100 mHz	10.00000 s ± 100 μs

PERFORMANCE TESTS

4-11 BURST

SPECIFICATION

A pre-programmed number of output cycles is generated on receipt of an input trigger signal or manual command, min time between bursts: 50 ns. Burst length: 1 to 9999 cycles.

EQUIPMENT

- Counter
- Cable Assembly BNC (61 cm)
- Feedthrough Termination 50 Ω (if necessary).

PROCEDURE

1. Load Burst number 8165 into 8165A.
2. Set 8165A as follows:

INPUT MODE	BURST
FUNCTION	SQUARE
DUTY CYCLE	50 %
FM	OFF
FRQ	10 kHz
AMPL	1 V
OFFSET	0 V
BURST	8165
OUTPUT MODE	ENABLE
	NORM
	50 Ω

3. Use figure 4-1 test setup and set counter to START.
4. Press 8165A's MAN button and verify that counter now displays the set number (8165) of output cycles. (5345A reading will be 8164, since first pulse arms the counter).

PERFORMANCE TESTS

4-12 AMPLITUDE AND OFFSET

SPECIFICATION

Amplitude and offset independently variable within ± 10 V. Source impedance: selectable $50 \Omega \pm 1\%$ or $1 \text{ k}\Omega \pm 10\%$, in parallel with 50 pF .

Ranges: 10.0 mV_{pp} to 10.0 V_{pp} (50Ω into 50Ω) and 2.00 V_{pp} to 20.0 V_{pp} ($1 \text{ k}\Omega$ into 50Ω).

Accuracy:	Sine	Square	Triangle (50%)	Ramp (20%, 80%)	Pulse (20%, 80%)
< 1 kHz	$\pm 2\%$	$\pm 2\%$	$\pm 2\%$	$\pm 2\%$	$\pm 2\%$
1 kHz – 5 MHz	$\pm 2\%$	$\pm 2\%$	$\pm 2\%$	$\pm 5\%$	$\pm 2\%$
5 MHz – 20 MHz	$\pm 5\%$	$\pm 5\%$	$\pm 10\%$	$\pm 10\%$	$\pm 5\%$
20 MHz – 50 MHz	$\pm 5\%$	$\pm 5\%$	$\pm 5\%$ to -20%	—	—

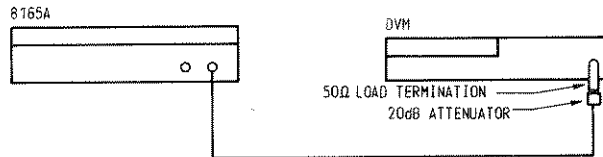

Figure 4-2. Test Setup for Amplitude and Offset.

EQUIPMENT

- Digital Voltmeter
 - Cable Assembly BNC (1 x 61 cm)
 - Feedthrough Termination 50Ω
 - Power Attenuator 20 dB, 20 W
- Total attenuation to be within $\pm 0.5\%$ of nominal.

PROCEDURE

1. Connect the equipment as shown in Figure 4-2.
2. Set 8165A as follows:

INPUT MODE	NORM
FUNCTION	SINE
DUTY CYCLE	50 %
FM	OFF
FRQ	10 kHz
OFFSET	0 V
OUTPUT MODE	ENABLE
	NORM
	1 k Ω

PERFORMANCE TESTS

3. Using best DVM resolution, measure the RMS voltages for the following 8165A settings:

OUTPUT MODE	AMPL	FUNCTION	DVM Reading
1 kΩ	20,0 V	Sine	0,693 V – 0,721 V
		triangle	0,566 V – 0,589 V
		square	0,980 V – 1,02 V
50 Ω	10,0 V	Sine	0,347 V – 0,361 V
		triangle	0,283 V – 0,294 V
		square	0,49 V – 0,51 V

4. Remove 20 dB attenuator and continue:

50 Ω	5,00 V	Sine	1,73 V – 1,80 V
		triangle	1,41 V – 1,47 V
		square	2,45 V – 2,55 V
50 Ω	3,00 V	Sine	1,039 V – 1,082 V
		triangle	,849 V – ,883 V
		square	1,47 V – 1,53 V
50 Ω	1,00 V	Sine	0,347 V – 0,361 V
		triangle	0,283 V – 0,294 V
		square	0,49 V – 0,51 V
50 Ω	100 mV	Sine	34,7 mV – 36,1 mV
		triangle	28,3 mV – 29,4 mV
		square	49 mV – 51 mV

5. Set 8165A to TRIG mode.

6. Using best DVM resolution, measure the dc voltages for the following 8165A settings:

OUTPUT MODE	OFFSET	DVM Reading
1 kΩ	10,0 V	9,880 V – 10,12 V
50 Ω	5,00 V	4,930 V – 5,070 V
50 Ω	3,00 V	2,950 V – 3,050 V

7. Remove 20 dB attenuator, and continue:

50 Ω	1,00 V	0,970 V – 1,030 V
50 Ω	100 mV	79 mV – 121 mV

PERFORMANCE TESTS

4-13 SINE CHARACTERISTICS

SPECIFICATION

Harmonic Components: Up to 5 MHz, THD < 1% of fundamental. Above 5 MHz, all harmonics at least 30 dB below fundamental.

Spurious: all non-harmonically related outputs at least 40 dB below fundamental.

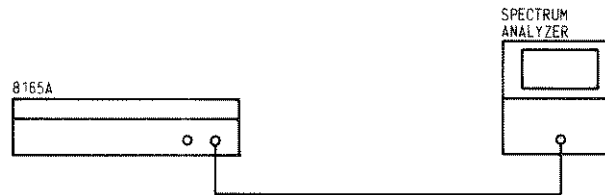

Figure 4-3. Test Setup for Sine Characteristics

EQUIPMENT

Spectrum analyzer
Cable assembly BNC (1 x 61 cm)

PROCEDURE

1. Connect the equipment as shown in Figure 4-3.
2. Set 8165A as follows:

INPUT MODE	NORM
FUNCTION	SINE
DUTY CYCLE	50 %
FM	OFF
FREQ	1 MHz
AMPL	1.99 V
OFFSET	0 V
OUTPUT MODE	ENABLE
		NORM
		50 Ω

3. Tune spectrum analyzer for minimum display amplitude. Adjust gain so that fundamental corresponds to 0 dB. Verify that the 2nd and 3rd harmonics do not exceed the - 42 and - 47 dB levels, respectively.

PERFORMANCE TESTS

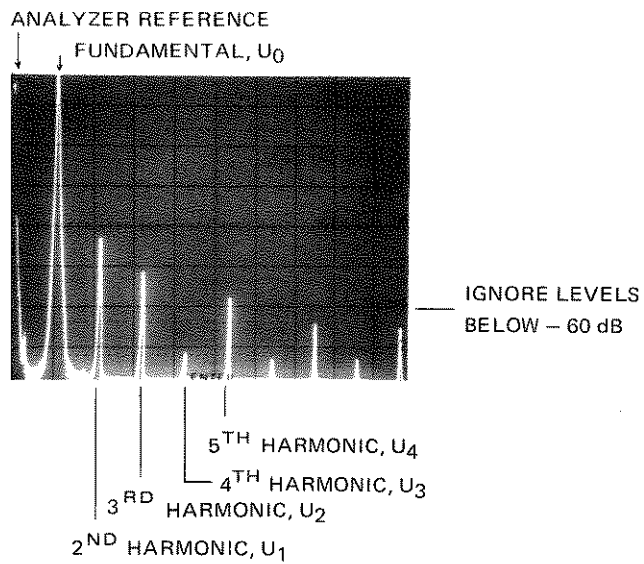

Figure 4-4. Typical Spectrum Analyzer Display at 1 MHz

4. Verify that $\text{THD} < 1\%$ ($\text{THD} = (U_1^2 + U_2^2 + U_3^2 + \dots) / 2, 100/U_0$)
5. Set 8165A FRQ to 50 MHz.
6. Tune spectrum analyzer for minimum display amplitude. Adjust gain so that fundamental corresponds to 0 dB. Verify that no harmonics exceed the -30 dB level.

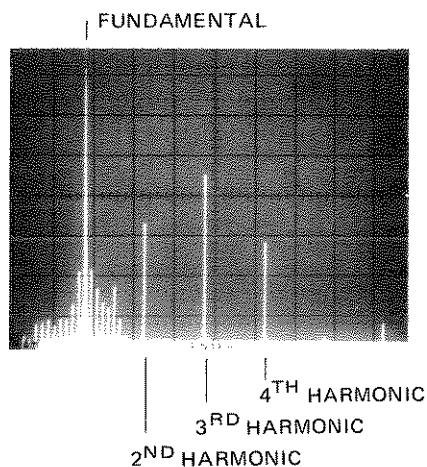

Figure 4-5. Typical Spectrum Analyzer Display at 50 MHz

PERFORMANCE TESTS

4-14 PULSE CHARACTERISTICS

SPECIFICATION

Transition times (10% to 90%): < 5 ns,
 < 7 ns (1 kΩ into 50 Ω).

Preshoot/Overshoot/Ringing: ± 5%,
 ±10% (1 kΩ into 50 Ω).

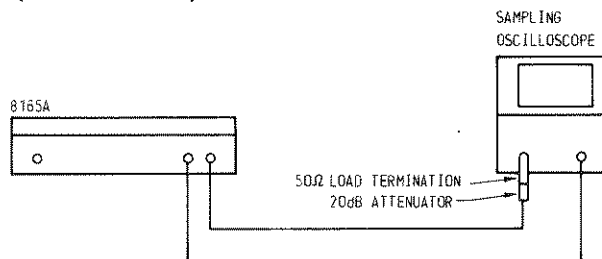

Figure 4-6. Test Setup for Pulse Characteristics.

EQUIPMENT

- Sampling oscilloscope
- Cable assembly BNC (2 x 61 cm)
- Feedthrough termination 50 Ω
- Power attenuator 20 dB, 20 W

PROCEDURE

1. Connect the equipment as shown in Figure 4-6.
2. Set the 8165A as follows:

INPUT MODE	NORM
FUNCTION	SQUARE
DUTY CYCLE	50 %
FM	OFF
FRQ	1 MHz
AMPL	1 V
OFFSET	0 V
OUTPUT MODE	ENABLE
		NORM
		50 Ω

3. Set scope so that one cycle fills the display (Figure 4-7).

- leading edge (risetime) ≤ 5 ns
- trailing edge (risetime) ≤ 5 ns
- preshoot ≤ ± 5 % of amplitude
- overshoot and ringing ≤ ± 5 % of amplitude

PERFORMANCE TESTS

4-15 RAMP CHARACTERISTICS

SPECIFICATION

Linearity (10 % to 90 %): $\pm 1\%$ (up to 5 MHz), $\pm 5\%$ (above 5 MHz)

EQUIPMENT

- Sampling oscilloscope
- Cable assembly BNC (2 x 61 cm)
- Feedthrough termination 50 Ω
- Power attenuator 20 dB, 20W

PROCEDURE

1. Connect the equipment as shown in Figure 4-6.
2. Set the 8165A as follows:

INPUT MODE	NORM
FUNCTION	TRIANGLE
DUTY CYCLE	50 %
FM	OFF
FRQ	1 MHz
AMPL	1 V
OFFSET	0 V
OUTPUT MODE	ENABLE
	NORM
	50 Ω

3. Set scope so that one cycle fills the display.
4. Verify leading edge non-linearity (Figure 4-7) $< \pm 1\%$ of amplitude.
5. Set 8165A output mode to INV and verify that signal changes polarity.

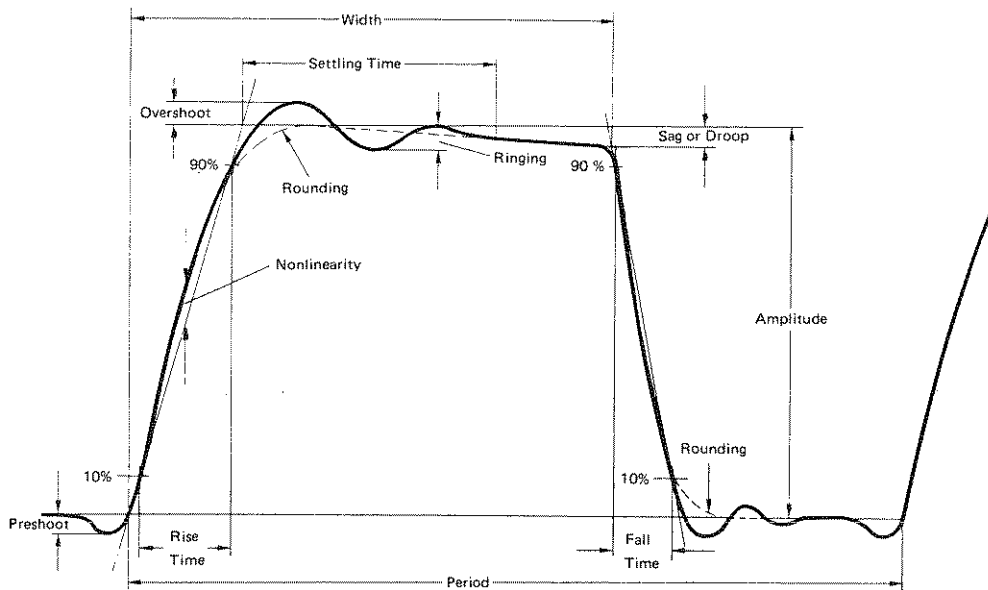

Figure 4-7. Pulse Parameters

PERFORMANCE TESTS

4-16 GATE AND TRIGGER PERFORMANCE

SPECIFICATION

Trig: pos. ext input pulse ≥ 10 ns wide generates one output cycle. Upper level $\geq +250$ mV, lower level ≤ 0 V.

Gate: oscillator enabled when ext input $\geq +250$ mV, disabled when ≤ 0 V. First and last output cycles are always complete.

Max input: ± 20 V

Input impedance: 10 k Ω typical

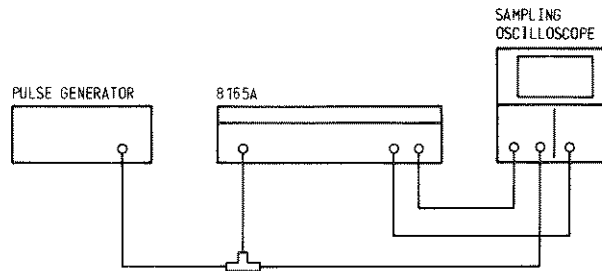

Figure 4-8. Test Setup for Burst Gate and Trigger Performance

EQUIPMENT

- Pulse generator
- Oscilloscope
- Cable assembly (3 x 61 cm, 2 x 30 cm)
- BNC Tee,
- Feedthrough termination 50 Ω

PROCEDURE

1. Connect the equipment as shown in Figure 4-8.
2. Set the 8165A as follows:

INPUT MODE	GATE
FUNCTION	SINE
DUTY CYCLE	50 %
FM	OFF
FRQ	100 kHz
AMPL	1 V
OFFSET	0 V
OUTPUT MODE	ENABLE
		NORM
		50 Ω

PERFORMANCE TESTS

- Set pulse generator for output pulse approx $50 \mu s$ wide, rep. rate 1 kHz, baseline zero or more negative, pulse top + 250 mV. Verify that each positive gate releases a burst of output cycles and that each cycle is complete (Figure 4-9).

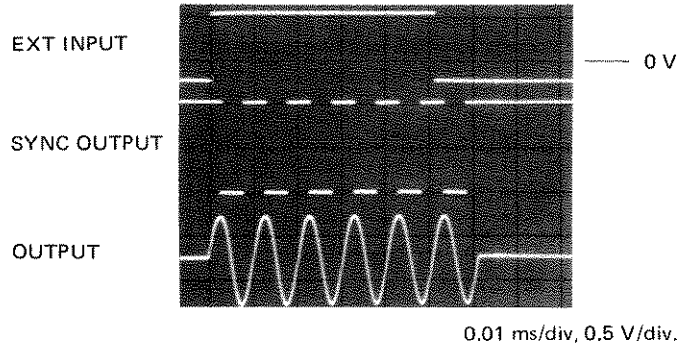

Figure 4-9. Example of correct gate operation

- Set 8165A to TRIG mode. Verify that each trigger pulse generator one complete output cycle (Figure 4-10).

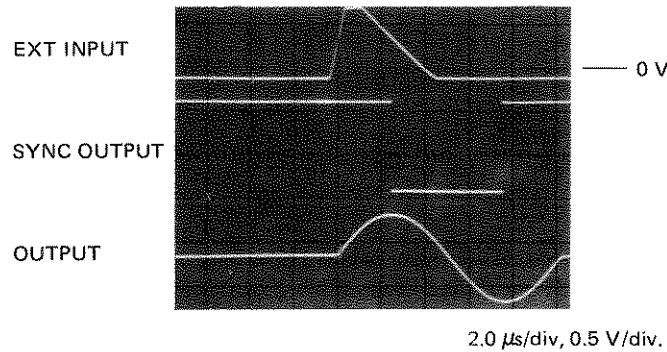

Figure 4-10. Example of correct trigger operation

PERFORMANCE TESTS

4-17 FM.

SPECIFICATION

Output is frequency modulated by an external voltage applied to a rear panel BNC, 0 to ± 1 V modulates 0 to ± 1 % deviation.

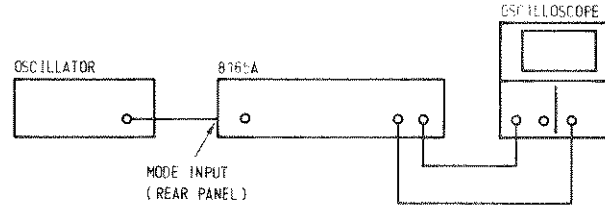

Figure 4-11. Test Setup for FM

EQUIPMENT

- Oscillator
- Oscilloscope
- Cable assembly BNC (3 x 61 cm)

PROCEDURE

1. Connect the equipment as shown in Figure 4-11.
2. Set oscillator to 10 kHz, 2 Vpp
3. Set oscilloscope to 1 μ s/div main timebase, 0.05 μ s/div delayed time base.
4. Set the 8165A as follows:

INPUT MODE	NORM
FUNCTION	SQUARE
DUTY CYCLE	50 %
FM	0 N
FRQ	1 MHz
AMPL	1 V
OFFSET	0 V
OUTPUT MODE	ENABLE
		NORM
		50 Ω

5. Check the delayed sweep for a jitter of 2 div \pm 10 %.
6. Turn FM off, verify that the delayed sweep jitter \leq 0.2 div.

PERFORMANCE TESTS

4-18 SWEEP (OPTION 002 ONLY)

SPECIFICATION

Provides logarithmic up/down sweep up to 3 decades between limits set on the 8165A.
As in VCO mode, 4 bands limited to less than 3 decades Min frequency 1 mHz.

Sweep-rate: 0.01, 0.1, 1, 10, 100, 1000 seconds per decade selectable.

Trigger: one up-down sweep per trigger pulse (upper level $\geq +250$ mV, lower level ≤ 0 V, width > 10 ns).

Accuracy: sweep start frequency: $\pm 15\% \pm 0.5\%$ of max. stop frequency
sweep stop frequency: $\pm 15\%$

Resolution: 2 digits

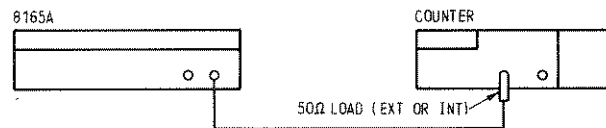

Figure 4-12. Test Setup for Sweep Option 002

EQUIPMENT

Counter
Cable assembly BNC (1 x 61 cm)
Feedthrough termination $50\ \Omega$ (if necessary).

PROCEDURE

1. Connect the equipment as shown in Figure 4-12.

PERFORMANCE TESTS

2. Set the 8165A as follows:

INPUT MODE	SWEEP: INT TRIG
FUNCTION	SINE
DUTY CYCLE	50 %
FM	OFF
FRQ	1 kHz
AMPL	2 V
OFFSET	0 V
OUTPUT MODE	ENABLE
	NORM
	50 Ω
SWEEP START	10 kHz
SWEEP STOP	10 kHz
SWEEP TIME	1 s/decade

3. Verify counter reading for the following settings:

SWEEP START	SWEEP STOP	Counter reading
10 kHz	10 kHz	10 kHz \pm 1.5 kHz
1 MHz	1 MHz	1 MHz \pm 150 kHz
40 MHz	40 MHz	40 MHz \pm 4.2 MHz

PERFORMANCE TESTS

4-19 AMPLITUDE MODULATOR (Option 002 only)

SPECIFICATION

(Option 002 only): 0 to 2.5 V_{pp} modulates 0 to 100 % modulation depth.

Modulating Frequency: dc to 10 MHz (-3 dB).

Input Impedance: 10 kΩ typical.

Pulse Modulation: transition times < 50 ns.

Envelope Distortion: (dc to 250 kHz mod. freq.):

Carrier	Modulation	Distortion
≤ 1 MHz	0 to 90 %	< 1 %
> 1 MHz	0 to 30 %	< 3 %

Carrier Frequency Deviation: < 0.01 %, 0 to 30 % modulation.

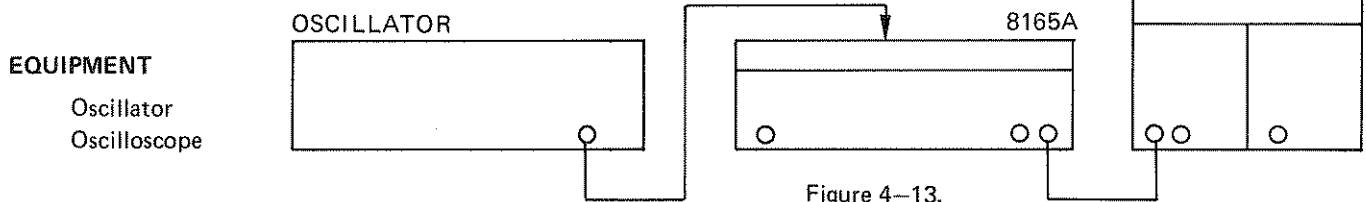

PROCEDURE

1. Connect the equipment as shown in Figure 4-13.
2. Set the 8165A as follows:

INPUT MODE	NORM
FUNCTION	SINE
DUTY CYCLE	50 %
FM	OFF
FRQ	100 kHz
AMPL	
OFFSET	0 V
OUTPUT MODE	ENABLE
		NORM
		50 Ω
SWEEP START	10 kHz
SWEEP STOP	10 kHz
SWEEP TIME	1 s/decade
AM	ON

3. Set oscillator for 1 kHz and 2.5 V_{pp} amplitude.
4. The display should be of a modulation depth of 100 %.

PERFORMANCE TESTS

4-20 STORE/RECALL CAPABILITY

SPECIFICATION

10 addressable store locations plus one for existing operating state. Each location can store a complete set of operating parameters and modes.

Access time: 20 ms each location.

Storage time: internal battery provides memory retention for approx 4 weeks at room temperature.

PROCEDURE

- Set the 8165A as follows:

INPUT MODE	NORM
FUNCTION	TRIANGLE
DUTY CYCLE	20 %
FM	ON
FRQ	11.11 kHz
AMPL	2 V
OFFSET	+ 1 V
OUTPUT MODE	ENABLE
		NORM
		50 Ω

- Press STO and 1.

- Set the 8165A as follows:

INPUT MODE	BURST
FUNCTION	SQUARE
DUTY CYCLE	80 %
FM	OFF
FRQ	19.9 MHz
AMPL	5 V
OFFSET	- 2 V
BURST	99
OUTPUT MODE	DISABLE
		INV
		1 k Ω

- Press STO and 2.
- Press RCL and 1, verify that the settings of step 1 are displayed.
- Press RCL and 2, verify that the settings of step 3 are displayed.

PERFORMANCE TESTS

4-21 HP-IB CAPABILITY

SPECIFICATION

Accuracy: See Frequency Characteristics, Output Characteristics.

Settling times:

Frequency: < 20 ms to $\pm 5\%$ of programmed value. In

Norm mode, and in Trig, Gate, Burst at frequencies

< 1 kHz : < 70 ms to $\pm 2\%$ of programmed value,

< 300 ms to final value.

Other Functions: 20 ms. The following range changes can take up to 200 ms:

Change of duty cycle.

Selection to or from Sweep/VCO.

Changing up to/down from the following decades:

Frequency 1 kHz, 10 kHz, 100 kHz, 1 MHz, 20 MHz.

Amplitude 100 mV, 1 V

Offset 1 V.

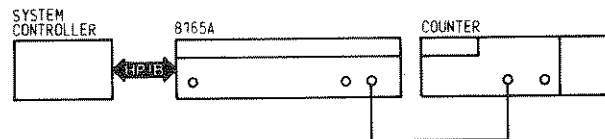

Figure 4-14. Test Setup for HP-IB Operation

EQUIPMENT

System controller

Counter

Cable assembly (1 x 61 cm)

PROCEDURE

1. Connect the equipment as shown in Figure 4-14.
2. Load program presented in Figure 3-16 (modify wait command in step 13 to 10 s — or as desired).
3. Run program and verify functional operation.
4. Verify accuracy of first and last programmed frequencies:

Programmed frequency	Counter reading
440 Hz	440 Hz \pm 4.4 mHz
739.99 Hz	739 Hz \pm 7.4 mHz

PERFORMANCE TESTS

Table 4-4. Performance Test Record (1 of 3)

Hewlett-Packard Company Model 8165A/8165A Option 002 Programmable Signal Source Serial No. _____				Tested By _____ Date _____		
Para. No.	Test Description			Results		
				Actual	Min	Max
4-10	Frequency					
	50.0 MHz			49.9995 MHz	_____	50.0005 MHz
	10.0 MHz			9.9999 MHz	_____	10.0001 MHz
	10.0 kHz			9.9999 kHz	_____	10.0001 kHz
	1.00 kHz			0.9999 kHz	_____	1.00001 kHz
	1.00 Hz			0.99999 s	_____	1.00001 s
	100 mHz			9.99990 s	_____	10.00001 s
4-11	Burst Number of actual output cycles same as set burst length ?				yes/no	
4-12	Amplitude and Offset					
	OUTPUT MODE	AMPL	FUNCTION			
	1 kΩ	20.0 V	sine	0.693 V	_____	0.721 V
			triangle	0.566 V	_____	0.589 V
			square	0.980 V	_____	1.02 V
	50 Ω	10.0 V	sine	0.347 V	_____	0.361 V
			triangle	0.283 V	_____	0.294 V
			square	0.49 V	_____	0.51 V
	50 Ω	5.00 V	sine *	1.73 V	_____	1.80 V
			triangle *	1.41 V	_____	1.47 V
			square *	2.45 V	_____	2.55 V
	50 Ω	3.00 V	sine *	1.039 V	_____	1.082 V
			triangle *	0.849 V	_____	0.883 V
			square *	1.47 V	_____	1.53 V
	50 Ω	1.00 V	sine *	0.347 V	_____	0.361 V
			triangle *	0.283 V	_____	0.294 V
			square *	0.49 V	_____	0.51 V
	50 Ω	100 mV	sine *	34.7 mV	_____	36.1 mV
			triangle *	28.3 mV	_____	29.4 mV
			square *	49 mV	_____	51 mV
	* Remove 20 dB attenuator					

PERFORMANCE TESTS

Table 4-4. Performance Test Record (2 of 3)

Para No.	Test Description	Results		
		Min	Actual	Max
	<p>OUTPUT OFFSET MODE</p> <p>1 kΩ 10.0 V 50 Ω 5.00 V 50 Ω 3.00 V</p> <p>50 Ω 1.00 V 50 Ω 100 mV</p>	<p>9.880 V 4.930 V 2.950 V</p> <p>0.970 V 79 mV</p>	<p>_____</p> <p>_____</p> <p>_____</p> <p>_____</p> <p>_____</p>	<p>10.12 V 5.070 V 3.050 V</p> <p>1.030 V 121 mV</p>
4-13	<p>Sine Characteristics (Harmonic level)</p> <p>FRQ = 1 MHz (2nd harmonic) FRQ = 1 MHz (3rd harmonic) FRQ = 1 MHz (THD) FRQ = 50 MHz (worst harmonic)</p>		<p>_____</p> <p>_____</p> <p>_____</p> <p>_____</p>	<p>-42 dB -47 dB 1 % -30 dB</p>
4-14	<p>Pulse Characteristics</p> <p>Leading edge Trailing edge Preshoot Overshoot and ringing</p>	<p>≤ -5 % ≤ -5 %</p>	<p>_____</p> <p>_____</p> <p>_____</p> <p>_____</p>	<p>≤ 5 ns ≤ 5 ns ≤ +5 % ≤ +5 %</p>
4-15	<p>Ramp Characteristics</p> <p>Leading edge linearity INV/NORM selection o.k. ?</p>	<p>≤ -1 %</p>	<p>_____</p> <p>yes/no</p>	<p>≤ +1 %</p>
4-16	<p>Gate and Trigger</p> <p>Positive gate releases a burst of output cycles, first and last cycles complete ?</p> <p>Positive trigger releases one complete output cycle ?</p>		<p>_____</p> <p>_____</p> <p>yes/no</p> <p>_____</p> <p>yes/no</p>	
4-17	<p>FM Mode</p> <p>Jitter, FM on Jitter, FM off</p>	<p>1.8 div</p>	<p>_____</p> <p>_____</p>	<p>2.2 div 0.2 div</p>

PERFORMANCE TESTS

Table 4-4. Performance Test Record (3 of 3)

Para No.	Test Description	Results		
		Min	Actual	Max
4-18	Sweep Mode (Option 002 only) Sweep start = sweep stop: 10 kHz 1 MHz 40 MHz	8.5 kHz 850 kHz 35.8 MHz	_____ _____ _____	11.5 kHz 1.15 MHz 44.2 MHz
4-19	Amplitude Modular (Option 002 only) Modulation depth 100 %		_____ yes/no	
4-20	Store/Recall Capability Satisfactory ?		_____ yes/no	
4-21	HP-IB Capability Functionally ? Settling accuracy: 440 Hz 739.99 Hz	439.9956 Hz 738.9926 Hz	_____ yes/no _____ _____	440.0044 Hz 739.0074 Hz
8-6	Safety Check Satisfactory ?		_____ yes/no	

SECTION V ADJUSTMENTS

5-1 INTRODUCTION

5-2 This section describes the adjustments which will return the instrument to peak operating condition after repairs are completed. An adjustment location diagram is given on a fold-out page at the end of this section.

5-3 SAFETY CONSIDERATIONS

5-4 Although this instrument has been designed in accordance with international safety standards, this manual contains information, cautions, and warnings which must be followed to ensure safe operation and to retain the instrument in safe condition (see Sections II and III). Service and adjustments should be performed only by qualified service personnel.

WARNING

Any interruption of the protective (grounding) conductor (inside or outside the instrument or disconnection of the protective earth terminal is likely to make the instrument dangerous. Intentional interruption is prohibited.

5-5 Any adjustment, maintenance, and repair of the opened instrument with voltage applied should be avoided as much as possible and, when inevitable, should be carried out only by a skilled person who is aware of the hazard involved.

5-6 Capacitors inside the instrument may still be charged even if the instrument has been disconnected from its source of supply.

5-7 Make sure that only fuses with the required rated current and of the specified type (normal blow, time delay, etc.) are used for replacement. The use of repaired fuses and the shortcircuiting of fuseholders must be avoided.

5-8 Whenever it is likely that the protection offered by fuses has been impaired, the instrument must be made inoperative and secured against any unintended operation.

WARNING

Adjustments described herein are performed with power supplied to the instrument while protective covers are removed. Energy available at many points may, if contacted, result in personal injury.

5-9 EQUIPMENT REQUIRED

5-10 The test equipment required for the adjustment procedures is listed in Table 1-1, Recommended Test Equipment. The critical specifications of substitute test instruments must meet or exceed the standards listed in the table if the instrument is to meet the standards set forth in Table 1-2, Specifications.

5-11 ADJUSTMENT PROCEDURE

- § 5-17 Power Supplies
- § 5-18 VCO
- § 5-19 Output Amplifier and Offset Generator
- § 5-20 High Frequency
- § 5-21 VCO Control
- § 5-22 Reference Loop
- § 5-23 Baseline Centering
- § 5-24 Sweep Generator (option 002)
- § 5-25 Amplitude Modulator (option 002)

When repairs have been made, § 5-17 Power Supplies should always be carried out. Of the remaining paragraphs, only those which the repairs could affect need be done. Execute a paragraph completely and in the order in which it is presented. Only the significant instrument settings are given.

5-13 Allow a 1 hour warm-up time before starting the adjustments. During adjustments, keep the covers in place as far as is possible so that the instrument's temperature remains steady.

5-14 ADJUSTMENT RECORD

5-15 Results of adjustments may be tabulated on the Adjustment Record at the end of the adjustment paragraphs.

- 5 HF RAMP DISTORTION
- 5.1 Set 8165A frequency to 9.999 kHz.
- 5.2 Connect 10:1 Probe from Analyzer to A5TP10.
- 5.3 Set Analyzer:
 - Resolution bandwidth 300 Hz
 - Frequency span/div 5 kHz
 - Sweep time/div 0.2 s
 - Sweep mode repetitive
 - Input sensitivity 0.2 V
- 5.4 Adjust A15R35 for minimum 2nd harmonic (Figure 5-2). Verify level is 50 dB below fundamental or lower.

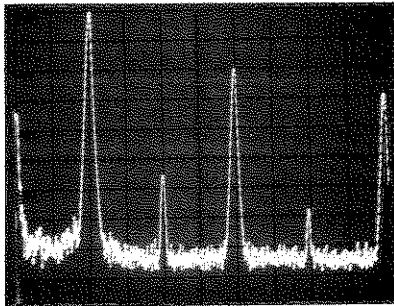

(Figure 5-2. Triangle Distortion Adjustment: LF)

- 6 TRIANGLE DISTORTION : HF
- 6.1 Connect the capacitor (0.47 μ F) between junction A5R50/R60 and ground.
- 6.2 Set 8165A FRQ to 50 MHz.
- 6.3 Adjust A15R37 for minimum 2nd harmonic. (Figure 5-3). Verify level is 50 dB below fundamental or lower.

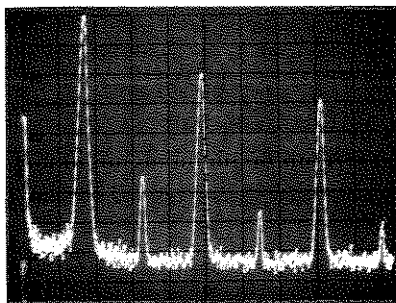

Figure 5-3. Triangle Adjustment: HF

- 6.4 Disconnect spectrum analyzer and capacitor.
- 7 VCO RANGE 1:999

- 7.1 Connect counter to 8165A's SYNC OUTPUT and set counter as follows:

Function Frequency A
 Channel A

- 7.2 Set Set 8165A's INPUT MODE to VCO and FRQ to 999 kHz.

- 7.3 Connect voltage source to 8165A's EXT INPUT and adjust source for 1 kHz reading on counter.

- 7.4 Measure voltage source, value should be 10 mV \pm 30 mV. Leave at setting obtained in 7.3 for the following adjustment. Disconnect counter.

8 VCO DISTORTION

- 8.1 Connect spectrum analyzer to 8165A's OUTPUT and set analyzer as follows:

Resolution bandwidth 300 Hz
 Frequency span/div 1 kHz
 Sweep time/div 0.1 s
 Sweep mode repetitive

- 8.2 Adjust A15R39 for min 2nd harmonic (Figure 5-4). Verify level is 35 dB below fundamental or lower.

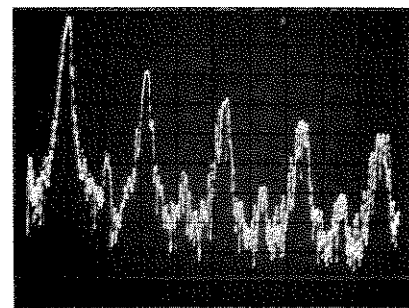

Figure 5-4. VCO Distortion Adjustment

- 8.3 Disconnect voltage source.

9 HF SINE DISTORTION

- 9.1 Connect spectrum analyzer to 8165A's OUTPUT and set as follows:

Resolution bandwidth 300 Hz
 Frequency span/div 5 kHz
 Sweep time/div 0.1 s
 Sweep mode repetitive

9.2 Change the following 8165A settings:

FUNCTION Sine
 INPUT MODE Norm
 and check that FRQ 9.999 kHz

9.3 Adjust A17R340/A16R350 for minimum harmonic (Figure 5-5). Verify that these levels are 42 dB below fundamental or lower.

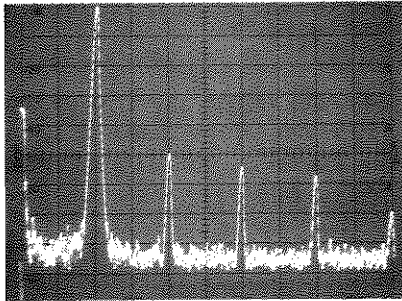

Figure 5-5. Sine Distortion Adjustment: 9.999 kHz

9.4 Set 8165A FRQ to 999 Hz.
 Set spectrum analyzer as follows:

Resolution bandwidth 100 Hz
 Frequency span 0.5 kHz

9.5 Adjust A10R227/206 for minimum harmonic (Figure 5-6). Verify that these levels are 42 dB below fundamental or lower.

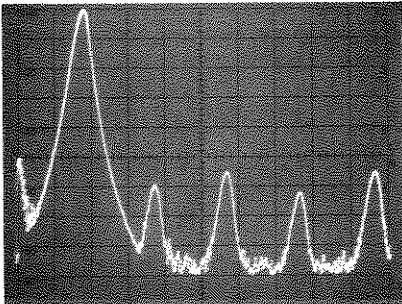

Figure 5-6. Sine Distortion Adjustment: 999 Hz

9.6 Disconnect the spectrum analyzer.

10 TRIANGLE AMPLITUDE

10.1 Connect DVM (ac) to A5TP9 and ground.

10.2 Set 8165A FRQ to 110 Hz and TRIANGLE.

10.3 Adjust A10R241 for 695 mV rms \pm 1 mV.

10.4 Change 8165A frequency to 9.999 kHz.
 Verify DVM reading of 695 mV \pm 2 mV.

10.5 Leave DVM in position.

5-4

11 SINE AND SQUARE AMPLITUDE

11.1 Set 8165A FUNCTION to sine. Adjust A17R360 for 850.7 mV rms \pm 1 mV.

11.2 Change frequency to 110 Hz. Verify DVM reading of 850.7 mV \pm 2 mV rms.

11.3 Set 8165A FUNCTION to square. Frequency to 9.999 kHz. Adjust A17R230 for 1204 mV rms \pm 2 mV.

11.4 Set 8165A frequency to 110 Hz. Verify DVM reading of 1204 mV \pm 3 mV rms.

12 SINE AND SQUARE DC BALANCE

12.1 Connect DVM (dc, floating between A5TP10/TP11).

12.2 Change 8165A's FUNCTION to sine, FRQ to 9.999 kHz.

12.3 Adjust A16R243 for 0 V \pm 1 mV.

12.4 Change 8165A's FUNCTION to square, adjust A16R240 for 0 V \pm 1 mV.

13 TRIANGLE DC BALANCE

13.1 Set 8165A's FUNCTION to triangle, FRQ to 999 Hz, INPUT MODE to TRIG. Leave DVM in its position (step 12.1).

13.2 Adjust A10R235 for 0 V \pm 1 mV.

5-19 Output Amplifier and Offset Generator

Pre-condition for this adjustment is a correctly adjusted VCO(5-18).

EQUIPMENT

Digital voltmeter, with cable and termination:
 total error < 0.5% at 1 kHz.
 Oscilloscope, 1:1 probe

Note: Use shielded cable for all dc-adjustments.

via 50 Ω cable and 50 Ω feedthrough termination. Note: total error DVM/cable/termination must be $< 0.5\%$ at 1 kHz.

8.2 Set 8165A OUTPUT MODE to NORM, SQUARE.

8.3 Adjust the following amplitude settings:

8165A AMPL (p-p)	Adjust	DVM Reading (rms)
1.99 V	A6R912	995 mV rms ± 1 mV
1.00 V	A6R810	500 mV rms ± 0.5 mV
1.50 V	A6R826	750 mV rms ± 0.5 mV

9 X2 AMPLIFIER GAIN

9.1 Leave DVM connected as given in step 8.1.

9.2 Adjust the following amplitude settings:

8165A AMPL	Adjust	DVM Reading
3.99 V	A4R306	1,995 V rms ± 1 mV
5.99 V	A6R920	2,995 V rms ± 2 mV
7.99 V	A6R915	3,995 V rms ± 3 mV

10 OFFSET RANGE

10.1 Set 8165A OFFSET TO +2.56 V, AMPL 10 mV, INPUT MODE to TRIG. FUNCTION to TRIANGLE.

10.2 Connect DVM (dc) to 8165A OUTPUT.

10.3 Adjust A6R614 for + 2.560 V ± 1 mV.

11 OFFSET D/A CONVERTER

11.1 Set 8165A OFFSET to + 2.55 V.

11.2 Adjust A6R601 for + 2.550 V ± 1 mV.

12 OFFSET: LINEARITY

12.1 Set 8165A OFFSET to + 5.00 V, OUTPUT MODE 1 k Ω , AMPL 2 V.

12.2 Adjust A6R610 for + 5.000 V.

12.3 Set 8165A OUTPUT MODE to 50 Ω and verify DVM reads + 5.000 V ± 10 mV.

13 OFFSET: + 999 mV RANGE

13.1 Set 8165A OFFSET to + 999 mV, IMP 50 Ω , AMPL 10 mV.

13.2 Adjust A12R4 for + 999 mV ± 1 mV.

14 OFFSET: - 999 mV RANGE

14.1 Set 8165A OFFSET to - 999 mV.

14.2 Adjust A12R23 for - 999 mV ± 1 mV.

14.3 Set 8165A OFFSET to - 5.00 V and verify that DVM reads - 5.000 V ± 10 mV.

14.4 Disconnect DVM.

5-20 HIGH FREQUENCY ADJUSTMENTS

EQUIPMENT:

Sampling scope
Power attenuator 20 dB

1 SQUARE WAVE RESPONSE

1.1 Connect sampling scope via 20 dB attenuator and feedthrough termination to 8165A OUTPUT. Trigger from SYNC OUTPUT.

1.2 Set 8165A FRQ to 10 MHz, square wave. Adjust for best pulse shape in each of the following ranges:

8165A	Adjust
10.0 V	A4C106/R115/C513/R526
999 mV	A4C512/R525
99 mV	A4C511/R524

Verify that, in all cases, overshoot (Figure 4-9) $\leq \pm 5\%$ of amplitude, transition times ≤ 5 ns.

- 1.3 Set 8165A OUTPUT MODE to 1 kΩ and verify that the transition times at the above amplitude ranges are ≤ 7 ns and pulse perturbation is ≤ ± 10%.
- 2 50 MHz WAVEFORMS
 - 2.1 Set 8165A FRQ to 1 MHz, AMPL 1.99 V, square wave.
 - 2.2 Connect sampling scope to 8165A output. Adjust sampling scope for an exact 10-div. p-p amplitude display as reference.
 - 2.3 Set 8165A FRQ to 50 MHz, waveform to triangle.
 - 2.4 Adjust the triangle offset and amplitude for a signal between 0.5 Div to 9.0 Div via A5R10 and A5R51.
Be sure frequency is 50 MHz as in 5-21 step 3.2.

50 MHz SQUARE

- 3.1 Set 8165A FUNCTION to square.
- 3.2 Adjust A5R235 for 50 % duty cycle.
- 3.3 Set 8165A FUNCTION to sine.
- 3.4 Adjust A5C309 for 9.7 Div. signal.
- 3.5 Remove sampling scope.

5-21 VCO Control

EQUIPMENT

- Digital voltmeter
- Counter
- Voltage source (TTL)

Note: Use shielded cable for all dc-adjustments.

PROCEDURE

1 D/A CONVERTER

1.1 Set 8165A as follows:

```

INPUT MODE ..... GATE
FUNCTION ..... Square
DUTY CYCLE ..... 50 %
FM ..... OFF
FRQ ..... 2.56 kHz
AMPL ..... 1.00 V
OFFSET ..... 0.0 V
OUTPUT MODE ..... ENABLE
                                     NORM
                                     50 Ω
    
```

- 1.2 Connect DVM (dc mode) between A8TP3 and ground. Apply voltage source to EXT INPUT.
- 1.3 Adjust A8R318 for 2.56 V ± 1 mV.
- 1.4 Set 8165A FRQ to 2.55 kHz.
- 1.5 Adjust A8R313 for 2.55 V ± 1 mV. Re-check steps 1.3 to 1.5.

2 RANGE START

- 2.1 Connect counter to SYNC OUTPUT. Set 8165A FRQ to 1.00 kHz, connect DVM (dc, floating) across A8TP4/5. Change polarity of DVM if counter reading drops.
- 2.2 Adjust A9R429 for 0 V ± 0.5 mV.
- 2.3 Remove DVM.

3 RANGE END

3.1 Connect voltage source to EXT INPUT. Verify and, if necessary, adjust the frequency at the following settings:

8165A FRQ	Adjust	Counter Reading
9.999 kHz	A8R405	9.999 kHz ± 1 %
99.9 kHz	A5(*C23)	99.9 kHz ± 2 %
999 kHz	A5(*C23)	999 kHz ± 2 %
9.99 MHz	A8R409	9.99 MHz
1.00 MHz	A8(*R433)	1 MHz ± 3 %

19.9 MHz	A8R412	19.9 MHz
10.0 MHz	A8(*R436)	10.0 MHz \pm 3 %
20.0 MHz	A8R407	20.0 MHz
35.0 MHz	A8R420	35.0 MHz
50.0 MHz	A8R418	50.0 MHz **

* If frequency is out of specification in one of the ranges, change factory selected part.

** If frequency is too high, lower 20 MHz adjust and re-adj 35 MHz and 50 MHz. If necessary find best compromise between step 3.2 and para 5--20 steps 2 to 2.4.

5-22 Reference Loop

EQUIPMENT

- Counter
- Spectrum analyzer
- Pulse generator
- Voltage source
- Oscilloscope
- 10:1 probe
- 1:1 probe

PROCEDURE

- 1 OSCILLATOR FREQUENCY
 - 1.1 Set 8165A as follows:
 INPUT MODE NORM
 FUNCTION Sine
 FM OFF
 - 1.2 Connect counter via 10:1 probe to A9TP1.
 - 1.3 Adjust A9C602 for a frequency of 10.000000 kHz \pm 5 mHz.
 - 1.4 Disconnect counter.
 - 2 SINE SHAPER DISTORTION (PLL)
 - 2.1 Connect scope to A9TP4 via 10:1 probe.
 - 2.2 Set 8165A INPUT MODE to GATE and FRQ to 3 kHz.
 - 2.3 Apply + 1 V from voltage source to 8165A EXT INPUT.
- 5-8

- 2.4 Adjust with A9R313 and A9R310 the signal amplitude and offset for best sine waveform.
- 2.5 Check the signal waveform between 1 kHz and 9.9 kHz.
- 2.6 Re-adjust A9R313, R310, if necessary, for best compromise.
- 3 MIXER BALANCE
 - 3.1 Connect scope via 10:1 probe to A9TP5.
 - 3.2 Set 8165A to 2 kHz.
 - 3.3 Adjust A9R406 for min. pulse amplitude.
 - 3.4 Check the pulse amplitude between 1 kHz and 9.9 kHz for \leq 130 mVp-p.

5-23 BASELINE CENTERING

- 1 EXTERNAL TRIGGER LEVEL
 - 1.1 Set external pulse generator to: frequency 500 Hz, amplitude 150 mV p-p, offset + 25 mV.
 - 1.2 Connect pulse generator to EXT INPUT and oscilloscope to 8165A output.
 - 1.3 Set 8165A INPUT MODE to GATE, FRQ to 1 kHz.
 - 1.4 Adjust A7R4 for a stable gated output signal.
 - 1.5 Check operation with 8165A FRQ 999 Hz.
- 2 GATE BASELINE
 - 2.1 Connect pulse generator output to 8165A's EXT INPUT, pulse generator trigger output to scope ext trigger, 8165A OUTPUT to scope channel A.
 - 2.2 Set pulse generator to square wave, baseline

5-25 Amplitude Modulator (Option 002 only)

EQUIPMENT

Digital Voltmeter. Use shielded cable for all adjustments.
LF Spectrum Analyzer.

PROCEDURE

Set 8165A as follows:

INPUT MODE	NORM
FUNCTION	TRIANGLE
DUTY CYCLE	50 %
FM	OFF
FRQ	9.999 kHz
AMPL	1.99 V
OFFSET	0 V
OUTPUT MODE	NORM, ENABLE 50 Ω
AM	ON

- 1 INPUT BALANCE
 - 1.1 Connect DVM (dc) to MOD INPUT.
 - 1.2 Adjust A13R102 for $0 \text{ V} \pm 1 \text{ mV}$.
(If necessary change R101).
- 2 AMPLITUDE AT 0 % MODULATION
 - 2.1 Set 8165A FUNCTION to SQR.
 - 2.2 Connect DVM (ac) to 8165A output via 50Ω termination. Note: total Error DVM/cable/termination must be $\leq 0.5 \%$.
 - 2.3 Adjust A13R142 for $497.5 \text{ mV} \pm 1 \text{ mV}$.
Remove DVM.
- 3 ENVELOPE DISTORTION
 - 3.1 Set 8165A AMPL 999 mV, FUNCTION SINE.
 - 3.2 Connect LF spectrum analyzer via 50Ω termination to 8165A output.
 - 3.3 Apply a 1 kHz/2.55 V p-p sinewave (THD $\leq 0.1 \%$) to MOD INPUT.

5-10

- 3.4 The display should be of a modulation depth between 6 dB to 7 dB below the fundamental carrier frequency.

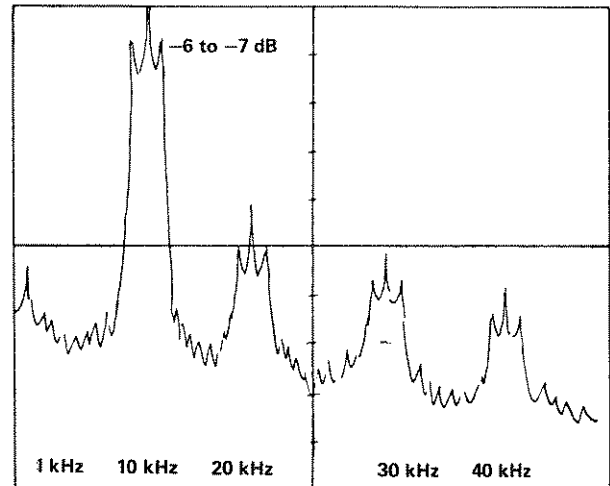

Figure 5-10. Envelope Distortion

- 3.5 Adjust A13R210 for a minimum distortion by the third sideband signal.
- 3.6 Adjust A13R128 for minimum modulating frequency ($\leq -60 \text{ dB}$). Remove spectrum analyzer.
- 4 OUTPUT DC BALANCE
 - 4.1 Set 8165A AMPL 10 V.
 - 4.2 Connect DVM (dc) to 8165A output.
 - 4.3 Adjust A13R123 for $0 \text{ V} \pm 2 \text{ mV}$.
 - 4.4 Set OUTPUT MODE to INV, DVM reading should be $0 \text{ V} \pm 10 \text{ mV}$. Remove DVM.

Table 5-1. Adjustment Record (1 of 6)

Hewlett-Packard Company Model 8165A Programmable Signal Source Serial No. _____				Adjusted by _____ Date _____		
Para No.	Adjustment		Adjust	Results		
	Step	Description		Min	Actual	Max.
5-17	2	Power Supplies				
		TP A5 + 5 V	A6R516	4.990 V dc	_____	5.010 V dc
		TP A5 - 5 V	A6R523	-4.990 V dc	_____	-5.010 V dc
		TP A5 + 20 V	A6R302	19.98 V dc	_____	20.02 V dc
		TP A5 - 20 V	A6R402	-19.98 V dc	_____	-20.02 V dc
		TP A5 + 17 V	-	16.5 V dc	_____	17.5 V dc
		TP A5 - 29 V	-	28.5 V dc	_____	29.5 V dc
5-18		Voltage-Controlled Oscillator (use shielded cables)				
	1	Current Source Balance				
	1.2	A5 TP1/2 A5TP3/4	A5R33	-5 mV dc E	E _____ _____	+5 mV dc E
	2	Triangle Amplitude (VCO)				
	2.1	A5 TP9	A5R71	694 mV rms	_____	695 mV rms
	3	Output Driver Balance				
	3.1	A5 TP10/11	A16R430	-0.5 mV dc	_____	+ 0.5 mV dc
	4	LF D/A Conv. Ramp Dist.				
	4.1	A10 TP1	A10R212		_____	
	5	HF Ramp Distortion				
	5.2	A5 TP10				
	5.3		A15R35		_____	-50 dB
	6	Triangle Distortion				
	6.1	A5 R50/R60				
6.3		A15R37		_____	- 50 dB	
7	VCO Range 1:999 (Ext INPUT dc) (1 kHz output)			_____	40 mV dc	

Table 5-1. Adjustment Record (2 of 6)

Para No.	Adjustment		Adjust	Results		
	Step	Description		Min	Actual	Max.
5-18	8	VCO Distortion				
	8.2		A15R39		_____	- 35 dB
	9	HF Sine Distortion				
	9.3	(9.999 kHz)	A17R340 A16R350		_____	- 42 dB
	9.5	(999 Hz)	A10R227 A10R206		_____	- 42 dB
	10	Triangle Amplitude				
	10.1	A5 TP9 (110 Hz) (9.999 kHz)	A10R241	694 mV rms 693 mV rms	_____ _____	696 mV rms 697 mV rms
	11	Sine and Square Amplitude				
	11.1	A5 TP9 (9.999 kHz) Sine (110 Hz)	A17R360	849.7 mV rms 848.7 mV rms	_____ _____	851 mV rms 852 mV rms
	11.3	A5 TP9 (9.999 kHz) Square (110 Hz)	A17R230	1202 mV rms 1201 mV rms	_____ _____	1206 mV rms 1207 mV rms
	12	Sine and Square DC Balance				
	12.1	A5 TP10/11 Sine Square	A16R243 A16R240	-1 mV dc -1 mV dc	_____ _____	+ 1 mV dc + 1 mV dc
	13	Triangle DC Balance A5 TP10/11	A10R235	- 1 mV dc	_____	+ 1 mV dc
5-19		OUTPUT AMPLIFIER and OFFSET GENERATOR (use shielded cables)				
	1	Voltage Source Pre-Amp Balance				
	1.2	A4 TP3 (NORM) (INV)	A4R161	min. ampl.	_____ _____	≤ 10 mV p-p
	2	Vernier D/A Converter				
2.1	A6 TP1	A6R805	3.997 V dc	_____	4.003 V dc	

Table 5-1. Adjustment Record (3 of 6)

Para No.	Adjustment		Adjust	Results		
	Step	Description		Min	Actual	Max.
5-19	3	OP Amp Balance U3				
	3.2	A12 TP1/2	A12R20	-0.1 mV dc	_____	+ 0.1 mV dc
	3.4	OP Amp Balance U2				
	3.5	A12 TP3/4	A12R12	- 0.1 mV dc	_____	+ 0.1 mV dc
	4	OP Amp Balance U4				
	4.2	A12 TP5/6	A12R31	-0.1 mV dc	_____	+ 0.1 mV dc
	5	Pre-Amp Dc-Balance				
	5.2	Output NORM-INV	A4R111	≤ 5 mV	_____	
	6	X1 Amplifier Balance				
	6.2	Output (NORM) (INV)	A6R1	-1 mV dc -10 mV dc	_____ _____	+ 1 mV dc 10 mV dc
	7	X2 Amplifier Balance				
	7.2	Output (NORM) (INV)	A6R2	-2 mV dc -20 mV dc	_____ _____	+ 2 mV dc + 20 mV dc
	8	X1 Amplifier Gain				
	8.3	Output (1.99 V) (1.00 V) (1.50 V)	A6R912 A6R810 A6R826	994 mV rms 499.5 mV rms 749.5 mV rms	_____ _____ _____	996 mV rms 500.5 mV rms 750.5 mV rms
	9	X2 Amplifier Gain				
	9.2	Output (3.99 V) (5.99 V) (7.99 V)	A4R306 A6R920 A6R915	1.994 V rms 2.993 V rms 3.992 V rms	_____ _____ _____	1.996 V rms 2.997 V rms 3.998 V rms
	10	Offset Range				
	10.3	Output	A6R614	2.559 V dc	_____	2.561 V dc
	11	Offset D/A Converter				
	11.2	Output	A6R601	2.549 V dc	_____	2.551 V dc
12	Offset Linearity					
12.2	Output (1 kΩ) (50 Ω)	A6R610	4.999 V dc 4.990 V dc	_____ _____	5.001 V dc 5.010 V dc	

Table 5-1. Adjustment Record (4 of 6)

Para No.	Adjustment		Adjust	Results		
	Step	Description		Min.	Actual	Max.
5-19	13	Offset +999 mV Range	A12R4	998 mV dc	_____	1.000 V dc
	13.2					
	14	Offset -999 mV Range (-5 V Range)	A12R23	-998 mV dc -4.990 V dc	_____ _____	-1.000 V dc -5.010 V dc
	14.3					
5-20	HIGH FREQUENCY ADJUSTMENTS					
	1	Square Wave Response				
	1.2	Output via 20 dB (10.0 V)	A4R115 A4C513 A4R526	Best response		overshoot $\leq \pm 5\%$ transition
		(999 mV)	A4C512 A4R525	Best response		≤ 5 ns (50 Ω)
		(99 mV)	A4R511 A4R524	Best response		≤ 7 ns (1 k Ω)
	2	50 MHz Waveforms				
	2.4	Triangle offset/amplitude	A5R10 A5R51	0.5 div		9.0 div
	3	50 MHz Square				
	3.2	Output 50% Duty cycle (sine)	A5R235 A5C309	9.7 div		
	5-21	VCO-CONTROL				
1		D/A Converter				
1.2		A6 TP3 (2.56 kHz) (2.55 kHz)	A8R318 A8R318	2.55 V 2.54 V	_____ _____	2.57 V 2.56 V
2		Range Start				
2.1		A8 TP4/5	A9R429	-0.5 mV dc	_____	+0.5 mV dc

Table 5-1. Adjustment Record (5 of 6)

Para No.	Adjustment		Adjust	Results		
	Step	Description		Min	Actual	Max.
5-21	3	Range End				
	3.2	9.99 kHz	A8R405	± 1 %	_____	
		99.9 kHz	A5 (*C23)	± 2 %	_____	
		999 kHz	A5 (*C23)	± 2 %	_____	
		9.99 MHz	A8R409		_____	
		1.00 MHz	A8 (*R433)	± 3 %	_____	
		19.9 MHz	A8R412		_____	
		10.0 MHz	A8 (*R436)	± 3 %	_____	
		20.0 MHz	A8R407		_____	
		35.0 MHz	A8R420		_____	
	50.0 MHz	A8R418		_____		
5-22		REFERENCE LOOP				
	1	Oscillator Frequency				
	1.3	A9 TP1	A9C602	9.999995 kHz	_____	10.000005 kHz
	2	Sine Shaper Distortion				
	2.1	A9 TP4 (Gate Mode 3 kHz) (1 kHz and 9.9 kHz)	A9R313 A9R310	Best sine waveform Best compromise		
	3	Mixer Balance				
3.3	A9 TP5 (2 kHz) (1 kHz and 9.9 kHz)	A9R406	minimum amplitude ≤ 130 mV p-p			
5-23		BASELINE CENTERING				
	1	External Trigger Level				
	1.4	Output	A7R4	stable signal	_____	
	2	Gate baseline				
2.3	Output	A5R115	center baseline	_____		

Table 5-1. Adjustment Record (6 of 6)

Para No.	Adjustment		Adjust	Results		
	Step	Description		Min	Actual	Max.
5-24	SWEEP GENERATOR (OPTION)					
	1	Sweep Voltage				
	1.3	Sweep out or A11 TP2	A11R410	2.995 V	_____	3.005 V
	1.5		A11R404	- 2 mV	_____	+ 2 mV
	2	Sweep Frequency				
	2.1	Sync out (1 kHz)	A11R423	1 kHz	_____	
	2.3	(990 kHz)	A11R428	990 kHz	_____	
	2.5	(100 kHz)	A11R426	100 kHz	_____	
	3	Sweep Time				
	3.3	Sweep out	A11R203	20 ms		
5-25	AMPLITUDE MODULATOR (OPTION)					
	1	Input Balance				
	1.2	Mod. Input	A13R102	- 1 mV	_____	+ 1 mV
	2	0 % Modulation				
	2.3	Output	A13R142	496.5 mV	_____	498.5 mV
	3	Envelope Distortion				
	3.5	Output	A13R210 A13R128	min. dist.	_____	≤ - 60 dB
	4	Output DC Balance				
	4.3	Output (NORM)	A13R123	- 2 mV	_____	+ 2 mV
4.4	(INV)		- 10 mV	_____	+ 10 mV	

Table 6-3. Replaceable Parts

Reference Designation	HP Part Number	C D	Qty	Description	Mfr Code	Mfr Part Number
A1	08165-66501	4		BD AY KEY		
A2	08165-66502	5		BD AY DISPLAY		
A3	08165-66503	6		BD AY PRCR		
A4	08165-66504	7		BD AY OUT AMPL		
A5	08165-66505	8		BD AY TIMING		
A6	08165-66506	9		BD AY PWR CONT		
A7	08165-66507	0		BD AY INP MOD		
A8	08165-66508	1		BD AY VCO CONT		
A9	08165-66509	2		BD AY REF LOOP		
A10	08165-66510	5		BD AY LOW FREQ G		
A12	08165-66512	7		BD AY OFFSET GEN		
A14	08165-66514	5		BD AY HP-IB		
A15	08165-66515	0		BD AY-RAMP ADJ		
A16	08165-66516	1		BD AY-SOURCES AD		
A17	08165-66517	2		BD AY-APTD ADJ		
B1	3160-0209	4	1	FAN-TBAX 32-CFM 105-125V 50/60-HZ	23936	8500C
C1	0160-3731	0	2	CAPACITOR-FXD .01UF +/-20% 1KVDC CER	28480	0160-3731
C2	0160-3731	0		CAPACITOR-FXD .01UF +/-20% 1KVDC CER	28480	0160-3731
C3	0160-4084	8	1	CAPACITOR-FXD .1UF +/-20% 50VDC CER	28480	0160-4084
CR1	1901-0496	1	2	DIODE-PWR RECT 100V 12A DO-4	04713	MR1121
CR2	1901-0496	1		DIODE-PWR RECT 100V 12A DO-4	04713	MR1121
J1	1250-0118	3	A	CONNECTOR-RF BNC FEM 8GL-HOLE=FR 50-OHM	28480	1250-0118
J2	1250-0118	3		CONNECTOR-RF BNC FEM 8GL-HOLE=FR 50-OHM	28480	1250-0118
J3	1250-0118	3		CONNECTOR-RF BNC FEM 8GL-HOLE=FR 50-OHM	28480	1250-0118
J4	1250-0118	3		CONNECTOR-RF BNC FEM 8GL-HOLE=FR 50-OHM	28480	1250-0118
J5	1250-0118	3		CONNECTOR-RF BNC FEM 8GL-HOLE=FR 50-OHM	28480	1250-0118
J7	1250-0118	3		CONNECTOR-RF BNC FEM 8GL-HOLE=FR 50-OHM	28480	1250-0118
J8	1250-0118	3		CONNECTOR-RF BNC FEM 8GL-HOLE=FR 50-OHM	28480	1250-0118
J9	1250-0118	3		CONNECTOR-RF BNC FEM 8GL-HOLE=FR 50-OHM	28480	1250-0118
MP1	01830-23201	3	1	COUPLER, SWITCH 10-24	28480	01830-23201
MP2	0370-0914	0	1	BEZEL-PB KNOB, .490LG, .330W, .165HI, JADE	28480	0370-0914
MP3	0380-0599	8	1	SPACER-HEADED, .125 ID, .438 DIA HO, .237	28480	0380-0599
MP4	0400-0077	1	1	GROMMET-RND, .375-IN-ID, .5-IN-GRV-OD	28480	0400-0077
MP5	0400-0193	2	1	GROMMET-SPCL, .221-IN-ID	28480	0400-0193
MP6	2260-0009	3	1	NUT-HEX-W/LKWR 4-40-THD, .094-IN-THK	00000	ORDER BY DESCRIPTION
MP7	08165-00202	4	1	PANEL, FRONT	28480	08165-00202
MP8	08165-00203	5	1	PANEL, SUB	28480	08165-00203
MP10	08165-01201	5	1	BRACKET, PC BOARD	28480	08165-01201
MP11	08165-01202	6	1	BRACKET, FAN	28480	08165-01202
MP12	08165-01204	8	1	BRACKET, HP-IB BOARD	28480	08165-01204
MP13	08165-21101	6	1	HEAT SINK	28480	08165-21101
MP14	08165-28101	0	1	WINDOW	28480	08165-28101
MP15	08165-60101	8	1	CHASSIS ASSEMBLY	28480	08165-60101
MP16	08165-60201	9	1	PANEL ASSEMBLY, REAR	28480	08165-60201
MP17	1200-0080	3	1	INSULATOR-DIO ALUMINUM HD-ANDZ	28480	1200-0080
MP18	1460-1345	5	1	TYL STAND SST	28480	1460-1345
MP19	5000-8915	9	1	COVER, TRANSFORMER, OLIVE BLACK	28480	5000-8915
MP19	5040-6011	6	2		28480	5040-6011
MP20	5001-0439	8	1	TRIM, FRONT SIDE	28480	5001-0439
MP21	5001-1206	9	1	PLATE, SAFETY POWER	28480	5001-1206
MP22	5001-1207	0	1	INSULATOR, POWER SWITCH	28480	5001-1207
MP24	5020-8803	6	1	FRAME, FRONT	28480	5020-8803
MP25	5020-8804	7	1	FRAME, REAR	28480	5020-8804
MP26	5020-8836	5	1	CORNER STRUT 15	28480	5020-8836
MP27	5040-1124	2	1	KNOB, PUSHBUTTON, POWER	28480	5040-1124
MP28	5040-6010	5	1	KEY CAP, 0	28480	5040-6010
MP29	5040-6011	6	1	KEY CAP, 1	28480	5040-6011
MP30	5040-6012	7	1	KEY CAP, 2	28480	5040-6012
MP31	5040-6013	8	1	KEY CAP, 3	28480	5040-6013

Table 6-3. Replaceable Parts (cont'd)

Reference Designation	HP Part Number	C D	Qty	Description	Mfr Code	Mfr Part Number
MP32	5040-6014	9	1	KEY CAP, 4	28480	5040-6014
MP33	5040-6015	0	1	KEY CAP, 5	28480	5040-6015
MP34	5040-6016	1	1	KEY CAP, 6	28480	5040-6016
MP35	5040-6017	2	1	KEY CAP, 7	28480	5040-6017
MP36	5040-6018	3	1	KEY CAP, 8	28480	5040-6018
MP37	5040-6019	4	1	KEY CAP, 9	28480	5040-6019
MP38	5040-6020	7	1	KEY CAP, 0	28480	5040-6020
MP39	5040-7201	8	1	FOOT (STANDARD)	28480	5040-7201
MP40	5040-7202	9	1	TRIM, TOP	28480	5040-7202
MP41	5040-7219	8	1	STRAP, HANDLE, CAP=FRONT	28480	5040-7219
MP42	5040-7220	1	1	STRAP, HANDLE, CAP=REAR	28480	5040-7220
MP43	5040-7221	2	1		28480	5040-7221
MP44	5040-7756	6	1		28480	5040-7756
MP45	5040-9305	7	1	KEY, LARGE, OLIVE BEIGE	28480	5040-9305
MP46	5040-9306	8	1	KEY, LARGE, OLIVE GREY	28480	5040-9306
MP47	5040-9307	9	1	KEY, LARGE, GOLD	28480	5040-9307
MP48	5041-0309	5	1	KEY CAP, QUARTER	28480	5041-0309
MP49	5041-0318	6	1	LOCK CAP, PLY GREY	28480	5041-0318
MP50	5060-9803	2	1		28480	5060-9803
MP51	5060-9834	9	1	COVER ASSY, TOP	28480	5060-9834
MP52	08170-64111	5	1	COVER ASSY, BOTTOM	28480	08170-64111
MP53	5060-9911	3	1	COVER, SIDE	28480	5060-9911
MP54	5060-9936	2	1	COVER, SIDE 15"	28480	5060-9936
MP55	9222-0608	5	1	COVER, OPERATION CARD	28480	9222-0608
MP56	08165-45201	7	1	HOUSING, LAMP	28480	08165-45201
MP60	5040-0702		6	INSULATING WASHER	28480	5040-0702
Q1	1853-0251	3	3	TRANSISTOR NPN SI PD090W FT=2MHZ	28480	1853-0251
Q2	1854-0433	5	2	TRANSISTOR NPN SI PD090W FT=2MHZ	28480	1854-0433
Q3	1853-0251	3		TRANSISTOR NPN SI PD090W FT=2MHZ	28480	1853-0251
Q4	1854-0433	5		TRANSISTOR NPN SI PD090W FT=2MHZ	28480	1854-0433
Q5	1853-0251	3		TRANSISTOR NPN SI PD090W FT=2MHZ	28480	1853-0251
S1	3101-1720	2	1	SWITCH-PB DPDT 4A 250VAC	28480	3101-1720
T1	08165-61101	0	1	TRANSFORMER, POWER	28480	08165-61101
W1	08165-61602		2	CBL AY INPUT	28480	08165-61602
W2	08165-61602			CBL AY SIGN OUTPUT	28480	08165-61602
W3	08165-61603			CBL AY SINC OUTPUT	28480	08165-61603
W4	08165-61604	8	1	CABLE ASSEMBLY, REFERENCE	28480	08165-61604
W5	08165-61605			CBL AY CONTROL CURRENT	28480	08165-61605
W6	08165-61606	2	1	CABLE, REAR PANEL	28480	08165-61606
W10	08165-61601	5	2	CABLE ASSEMBLY, COAX	28480	08165-61601
W11	08165-61601	5		CABLE ASSEMBLY, COAX	28480	08165-61601
W12	R120-1692	2	1	CABLE ASSY 3-CNDCT MQP-JXT	28480	R120-1692
XF1	2110-0569	3	1	FUSEHOLDER CAP 12A MAX FOR UL	28480	2110-0569
	2110-0565	9	1	FUSEHOLDER-EXTR POST 12A 250 V	28480	2110-0565
	2110-0566	0	1		28480	2110-0566
	1400-0090	9	1	FUSEHOLDER COMPONENT FOR USE ON	28480	1400-0090

Table 6-3. Replaceable Parts (cont'd)

Reference Designation	HP Part Number	C D	Qty	Description	Mfr Code	Mfr Part Number
A1	08165-66501	4	1	BOARD ASSEMBLY, KEY	28480	08165-66501
A1W9	50P1-1962	2	1	CABLE, RIBBON 14C 330MM	28480	5081-1962
A2	08165-66502	5	1	BOARD ASSEMBLY, DISPLAY	28480	08165-66502
A2C1	0160-0174	9	34	CAPACITOR-FXD .47UF +80-20% 25VDC CER	28480	0160-0174
A2C2	0160-0174	9		CAPACITOR-FXD .47UF +80-20% 25VDC CER	28480	0160-0174
A2C3	0180-1704	5	11	CAPACITOR-FXD 47UF+-10% 6VDC TA	56289	150D476X900682
A2C4	0180-1704	5		CAPACITOR-FXD 47UF+-10% 6VDC TA	56289	150D476X900682
A2D51	1990-0487	7	21	LED-VISIBLE LUM-INT=1MCD IF=20MA=MAX	28480	5082-4584
A2D52	1990-0487	7		LED-VISIBLE LUM-INT=1MCD IF=20MA=MAX	28480	5082-4584
A2D53	1990-0487	7		LED-VISIBLE LUM-INT=1MCD IF=20MA=MAX	28480	5082-4584
A2D54	1990-0487	7		LED-VISIBLE LUM-INT=1MCD IF=20MA=MAX	28480	5082-4584
A2D55	1990-0487	7		LED-VISIBLE LUM-INT=1MCD IF=20MA=MAX	28480	5082-4584
A2D56	1990-0487	7		LED-VISIBLE LUM-INT=1MCD IF=20MA=MAX	28480	5082-4584
A2D57	1990-0487	7		LED-VISIBLE LUM-INT=1MCD IF=20MA=MAX	28480	5082-4584
A2D510	1990-0487	7		LED-VISIBLE LUM-INT=1MCD IF=20MA=MAX	28480	5082-4584
A2D511	1990-0487	7		LED-VISIBLE LUM-INT=1MCD IF=20MA=MAX	28480	5082-4584
A2D512	1990-0487	7		LED-VISIBLE LUM-INT=1MCD IF=20MA=MAX	28480	5082-4584
A2D513	1990-0487	7		LED-VISIBLE LUM-INT=1MCD IF=20MA=MAX	28480	5082-4584
A2D514	1990-0487	7		LED-VISIBLE LUM-INT=1MCD IF=20MA=MAX	28480	5082-4584
A2D515	1990-0487	7		LED-VISIBLE LUM-INT=1MCD IF=20MA=MAX	28480	5082-4584
A2D516	1990-0487	7		LED-VISIBLE LUM-INT=1MCD IF=20MA=MAX	28480	5082-4584
A2D517	1990-0487	7		LED-VISIBLE LUM-INT=1MCD IF=20MA=MAX	28480	5082-4584
A2D518	1990-0487	7		LED-VISIBLE LUM-INT=1MCD IF=20MA=MAX	28480	5082-4584
A2D519	1990-0487	7		LED-VISIBLE LUM-INT=1MCD IF=20MA=MAX	28480	5082-4584
A2D520	1990-0487	7		LED-VISIBLE LUM-INT=1MCD IF=20MA=MAX	28480	5082-4584
A2D529	1990-0487	7		LED-VISIBLE LUM-INT=1MCD IF=20MA=MAX	28480	5082-4584
A2D530	1990-0487	7		LED-VISIBLE LUM-INT=1MCD IF=20MA=MAX	28480	5082-4584
A2D531	1990-0487	7		LED-VISIBLE LUM-INT=1MCD IF=20MA=MAX	28480	5082-4584
A2D532	1990-0485	5	1	LED-VISIBLE LUM-INT=800UCD IF=30MA=MAX	28480	5082-4984
A2D533	2140-0016	8	7	LAMP-INCAND 683 5VDC 60MA T=1-BULB	0000J	683
A2D534	2140-0016	8		LAMP-INCAND 683 5VDC 60MA T=1-BULB	0000J	683
A2D535	2140-0016	8		LAMP-INCAND 683 5VDC 60MA T=1-BULB	0000J	683
A2D536	2140-0016	8		LAMP-INCAND 683 5VDC 60MA T=1-BULB	0000J	683
A2D541	2140-0016	8		LAMP-INCAND 683 5VDC 60MA T=1-BULB	0000J	683
A2D542	2140-0016	8		LAMP-INCAND 683 5VDC 60MA T=1-BULB	0000J	683
A2D543	2140-0016	8		LAMP-INCAND 683 5VDC 60MA T=1-BULB	0000J	683
A2D551	1990-0452	6	12	DISPLAY-NUM=SEG 1=CHAR .3=H	28480	5082-7731, CAT C=E
A2D552	1990-0452	6		DISPLAY-NUM=SEG 1=CHAR .3=H	28480	5082-7731, CAT C=E
A2D553	1990-0452	6		DISPLAY-NUM=SEG 1=CHAR .3=H	28480	5082-7731, CAT C=E
A2D554	1990-0452	6		DISPLAY-NUM=SEG 1=CHAR .3=H	28480	5082-7731, CAT C=E
A2D555	1990-0452	6		DISPLAY-NUM=SEG 1=CHAR .3=H	28480	5082-7731, CAT C=E
A2D556	1990-0452	6		DISPLAY-NUM=SEG 1=CHAR .3=H	28480	5082-7731, CAT C=E
A2D557	1990-0452	6		DISPLAY-NUM=SEG 1=CHAR .3=H	28480	5082-7731, CAT C=E
A2D558	1990-0452	6		DISPLAY-NUM=SEG 1=CHAR .3=H	28480	5082-7731, CAT C=E
A2D559	1990-0452	6		DISPLAY-NUM=SEG 1=CHAR .3=H	28480	5082-7731, CAT C=E
A2D560	1990-0452	6		DISPLAY-NUM=SEG 1=CHAR .3=H	28480	5082-7731, CAT C=E
A2D561	1990-0452	6		DISPLAY-NUM=SEG 1=CHAR .3=H	28480	5082-7731, CAT C=E
A2D562	1990-0452	6		DISPLAY-NUM=SEG 1=CHAR .3=H	28480	5082-7731, CAT C=E
A2J4	1200-0589	7	12	SOCKET-IC 14=CONT DIP=8LDR	28480	1200-0589
A2J5	1200-0589	7		SOCKET-IC 14=CONT DIP=8LDR	28480	1200-0589
A2J6	1200-0589	7		SOCKET-IC 14=CONT DIP=8LDR	28480	1200-0589
A2J7	1200-0589	7		SOCKET-IC 14=CONT DIP=8LDR	28480	1200-0589
A2J8	1200-0589	7		SOCKET-IC 14=CONT DIP=8LDR	28480	1200-0589
A2J9	1200-0589	7		SOCKET-IC 14=CONT DIP=8LDR	28480	1200-0589
A2J10	1200-0589	7		SOCKET-IC 14=CONT DIP=8LDR	28480	1200-0589
A2J11	1200-0589	7		SOCKET-IC 14=CONT DIP=8LDR	28480	1200-0589
A2J12	1200-0589	7		SOCKET-IC 14=CONT DIP=8LDR	28480	1200-0589
A2J13	1200-0589	7		SOCKET-IC 14=CONT DIP=8LDR	28480	1200-0589
A2J14	1200-0589	7		SOCKET-IC 14=CONT DIP=8LDR	28480	1200-0589
A2J15	1200-0589	7		SOCKET-IC 14=CONT DIP=8LDR	28480	1200-0589
A2Q1	1854-0215	1	54	TRANSISTOR NPN 8I PD=350MW FT=300MHZ	04713	2N3904
A2Q2	1854-0215	1		TRANSISTOR NPN 8I PD=350MW FT=300MHZ	04713	2N3904
A2Q3	1854-0215	1		TRANSISTOR NPN 8I PD=350MW FT=300MHZ	04713	2N3904
A2Q4	1854-0215	1		TRANSISTOR NPN 8I PD=350MW FT=300MHZ	04713	2N3904
A2Q5	1854-0477	7	11	TRANSISTOR NPN 2N2222A 8I T0-18 PD=500MW	04713	2N2222A
A2Q6	1854-0477	7		TRANSISTOR NPN 2N2222A 8I T0-18 PD=500MW	04713	2N2222A
A2R1	0757-0706	8	9	RESISTOR 51.1 1% .25W F TC=0+-100	24546	C5=1/4=TO=51R1=F
A2R2	0757-0706	8		RESISTOR 51.1 1% .25W F TC=0+-100	24546	C5=1/4=TO=51R1=F
A2R3	0757-0706	8		RESISTOR 51.1 1% .25W F TC=0+-100	24546	C5=1/4=TO=51R1=F
A2R4	0757-0706	8		RESISTOR 51.1 1% .25W F TC=0+-100	24546	C5=1/4=TO=51R1=F
A2R5	0757-0280	3	78	RESISTOR 1K 1% .125W F TC=0+-100	24546	C4=1/8=TO=1001=F

Table 6-3. Replaceable Parts (cont'd)

Reference Designation	HP Part Number	C D	Qty	Description	Mfr Code	Mfr Part Number
A2P6	0757-0280	3		RESISTOR 1K 1% .125W F TC00±100	24546	C4=1/8-T0=1001=F
A2P7	0757-0280	3		RESISTOR 1K 1% .125W F TC00±100	24546	C4=1/8-T0=1001=F
A2P8	0757-0280	3		RESISTOR 1K 1% .125W F TC00±100	24546	C4=1/8-T0=1001=F
A2P9	0757-0280	3		RESISTOR 1K 1% .125W F TC00±100	24546	C4=1/8-T0=1001=F
A2P10	0757-0280	3		RESISTOR 1K 1% .125W F TC00±100	24546	C4=1/8-T0=1001=F
A2P11	0757-0281	4	4	RESISTOR 2.74K 1% .125W F TC00±100	24546	C4=1/8-T0=2741=F
A2P12	0757-0281	4		RESISTOR 2.74K 1% .125W F TC00±100	24546	C4=1/8-T0=2741=F
A2P13	0757-0281	4		RESISTOR 2.74K 1% .125W F TC00±100	24546	C4=1/8-T0=2741=F
A2P14	0757-0281	4		RESISTOR 2.74K 1% .125W F TC00±100	24546	C4=1/8-T0=2741=F
A2P15	069R-3155	1	11	RESISTOR 4.64K 1% .125W F TC00±100	24546	C4=1/8-T0=4641=F
A2P16	069R-3155	1		RESISTOR 4.64K 1% .125W F TC00±100	24546	C4=1/8-T0=4641=F
A2P17	0757-0417	8	4	RESISTOR 562 1% .125W F TC00±100	24546	C4=1/8-T0=562R=F
A2P18	1830-0162	5	1	NETWORK-RES 14=DISP4.7K OHM X 13	11230	760-1WR4.7K
A2P19	A159-0005	0	3	WIRE 22AWG W PVC 1X22 80C	28480	A159-0005
A2P20	A159-0005	0		WIRE 22AWG W PVC 1X22 80C	28480	A159-0005
A2P21	A159-0005	0		WIRE 22AWG W PVC 1X22 80C	28480	A159-0005
A2B1	5060-9436	7	17	PUSHBUTTON SWITCH P.C. MOUNT	28480	5060-9436
A2B2	5060-9436	7		PUSHBUTTON SWITCH P.C. MOUNT	28480	5060-9436
A2B3	5060-9436	7		PUSHBUTTON SWITCH P.C. MOUNT	28480	5060-9436
A2B4	5060-9436	7		PUSHBUTTON SWITCH P.C. MOUNT	28480	5060-9436
A2B5	5060-9436	7		PUSHBUTTON SWITCH P.C. MOUNT	28480	5060-9436
A2B6	5060-9436	7		PUSHBUTTON SWITCH P.C. MOUNT	28480	5060-9436
A2B7	5060-9436	7		PUSHBUTTON SWITCH P.C. MOUNT	28480	5060-9436
A2B8	5060-9436	7		PUSHBUTTON SWITCH P.C. MOUNT	28480	5060-9436
A2B9	5060-9436	7		PUSHBUTTON SWITCH P.C. MOUNT	28480	5060-9436
A2B10	5060-9436	7		PUSHBUTTON SWITCH P.C. MOUNT	28480	5060-9436
A2B11	5060-9436	7		PUSHBUTTON SWITCH P.C. MOUNT	28480	5060-9436
A2B12	5060-9436	7		PUSHBUTTON SWITCH P.C. MOUNT	28480	5060-9436
A2B14	5060-9436	7		PUSHBUTTON SWITCH P.C. MOUNT	28480	5060-9436
A2B15	5060-9436	7		PUSHBUTTON SWITCH P.C. MOUNT	28480	5060-9436
A2B24	5060-9436	7		PUSHBUTTON SWITCH P.C. MOUNT	28480	5060-9436
A2B25	5060-9436	7		PUSHBUTTON SWITCH P.C. MOUNT	28480	5060-9436
A2B26	5060-9436	7		PUSHBUTTON SWITCH P.C. MOUNT	28480	5060-9436
A2U1	1820-1200	5	1	IC INV TTL LS HEX	01295	SN74LS05N
A2U2	1820-0628	9	3	IC TTL 64-BIT RAM 60-NS 0=C	01295	SN7489N
A2U3	1820-0491	4	1	IC DCDP TTL BCD=TC=DEC 4=TO=10=LINE	01295	SN74145N
A2W1	5081-1980	4	2	CABLE, FIBRON ILC 279MM	28480	5081-1980
A2W2	5081-1980	4		CABLE, FIBRON ILC 279MM	28480	5081-1980
A2W3	5081-1981	5	1	CABLE, FIBRON 26C 305MM	28480	5081-1981
A3	08165-66503	6	1	BOARD ASSEMBLY, PROCESSOR	28480	08165-66503
A3B1	1420-0574	6	2	BATTERY 1.2V .15A=HR NI=CD SLDR=TAB	28480	1420-0574
A3B2	1420-0574	6		BATTERY 1.2V .15A=HR NI=CD SLDR=TAB	28480	1420-0574
A3C1	0160-4299	7	2	CAPACITOR-FXD 2200PF ±20% 250VDC CER	56289	C067F251F222MS22=CDH
A3C2	0180-1715	8	2	CAPACITOR-FXD 150UF ±10% 6VDC TA	56289	150D157X900682
A3C3	0160-4212	4	7	CAPACITOR-FXD .068UF ±20% 50VDC POLYE	28480	0160-4212
A3C4	0160-4212	4		CAPACITOR-FXD .068UF ±20% 50VDC POLYE	28480	0160-4212
A3C5	0160-4212	4		CAPACITOR-FXD .068UF ±20% 50VDC POLYE	28480	0160-4212
A3C6	0160-0174	9		CAPACITOR-FXD .47UF ±20% 25VDC CER	28480	0160-0174
A3C7	0180-1714	7	1	CAPACITOR-FXD 330UF ±10% 6VDC TA	56289	150D337X900682
A3C8	0180-1704	5		CAPACITOR-FXD 47UF ±10% 6VDC TA	56289	150D476X900682
A3C9	0180-0228	6	2	CAPACITOR-FXD 22UF ±10% 15VDC TA	56289	150D226X901582
A3C10	0160-0174	9		CAPACITOR-FXD .47UF ±20% 25VDC CER	28480	0160-0174
A3C11	0180-1704	5		CAPACITOR-FXD 47UF ±10% 6VDC TA	56289	150D476X900682
A3C12	0180-0197	8	6	CAPACITOR-FXD 2.2UF ±10% 20VDC TA	56289	150D225X9020A2
A3C13	0160-2150	5	7	CAPACITOR-FXD 33PF ±5% 300VDC MICA	28480	0160-2150
A3C14	0160-2150	5		CAPACITOR-FXD 33PF ±5% 300VDC MICA	28480	0160-2150
A3C15	0160-2150	5		CAPACITOR-FXD 33PF ±5% 300VDC MICA	28480	0160-2150
A3C16	0140-0192	9	3	CAPACITOR-FXD 68PF ±5% 300VDC MICA	72136	DM15E680J0300WV1CR
A3C17	0160-2150	5		CAPACITOR-FXD 33PF ±5% 300VDC MICA	28480	0160-2150
A3C18	0140-0192	9		CAPACITOR-FXD 68PF ±5% 300VDC MICA	72136	DM15E680J0300WV1CR
A3C19	0160-2055	9	10	CAPACITOR-FXD .01UF ±20% 100VDC CER	28480	0160-2055
A3C20	0160-0155	6	1	CAPACITOR-FXD 3300PF ±10% 200VDC POLYE	28480	0160-0155
A3C21	0160-4210	2	9	CAPACITOR-FXD .022UF ±20% 50VDC POLYE	28480	0160-4210
A3C22	0160-3724	1	1	CAPACITOR-FXD .47UF ±10% 40VDC	28480	0160-3724
A3C23	0160-3874	2	1	CAPACITOR-FXD 10PF ±.5PF 200VDC CER	28480	0160-3874
A3CR1	1901-0050	3	20	DIODE-SWITCHING 80V 200MA 2NS DO=35	28480	1901-0050
A3CR2	1901-0050	3		DIODE-SWITCHING 80V 200MA 2NS DO=35	28480	1901-0050
A3CR3	1901-0050	3		DIODE-SWITCHING 80V 200MA 2NS DO=35	28480	1901-0050
A3CR4	1901-0050	3		DIODE-SWITCHING 80V 200MA 2NS DO=35	28480	1901-0050
A3CR5	1901-0050	3		DIODE-SWITCHING 80V 200MA 2NS DO=35	28480	1901-0050

Table 6-3. Replaceable Parts (cont'd)

Reference Designation	HP Part Number	C D	Qty	Description	Mfr Code	Mfr Part Number
A3J1	1251-3024	8	3	CONNECTOR 26-PIN M RECTANGULAR	28480	1251-3024
A3J2	1251-3024	8		CONNECTOR 26-PIN M RECTANGULAR	28480	1251-3024
A3J3	1251-3024	8		CONNECTOR 26-PIN M RECTANGULAR	28480	1251-3024
A3J4	1200-0548	8	1	SOCKET-IC 14-COMT DIP DIP-SLDR	28480	1200-0548
A3J5	1200-0654	2	1	SOCKET-IC 40-COMT DIP-SLDR	28480	1200-0654
A3MP1	08160-02301	3	1	PC BOARD HOLDER	28480	08160-02301
A3MP2	4040-0750	7	2	EXTR-PC BD RED POLYC .062-BD-YHKNS	28480	4040-0750
A3MP3	4040-0750	7		EXTR-PC BD RED POLYC .062-BD-YHKNS	28480	4040-0750
A3MP4	0340-0451	7	1	INSULATOR-XSTR MICA	28480	0340-0451
A3Q1	1854-0330	1	1	TRANSISTOR NPN SI PD=21W FT=10MHZ	28480	1854-0330
A3Q2	1854-0477	7		TRANSISTOR NPN 2N2222A SI TO-18 PD=500MW	04713	2N2222A
A3Q3	1853-0086	2	16	TRANSISTOR PNP SI PD=310MW FT=40MHZ	27014	2N5087
A3Q4	1853-0086	2		TRANSISTOR PNP SI PD=310MW FT=40MHZ	27014	2N5087
A3Q5	1854-0215	1		TRANSISTOR NPN SI PD=350MW FT=300MHZ	04713	2N3904
A3Q6	1853-0036	2	34	TRANSISTOR PNP SI PD=310MW FT=250MHZ	28480	1853-0036
A3Q7	1853-0086	2		TRANSISTOR PNP SI PD=310MW FT=40MHZ	27014	2N5087
A3Q8	1854-0392	5	8	TRANSISTOR NPN SI PD=310MW FT=50MHZ	04713	2N5088
A3Q9	1854-0215	1		TRANSISTOR NPN SI PD=350MW FT=300MHZ	04713	2N3904
A3Q10	1854-0215	1		TRANSISTOR NPN SI PD=350MW FT=300MHZ	04713	2N3904
A3Q11	1854-0215	1		TRANSISTOR NPN SI PD=350MW FT=300MHZ	04713	2N3904
A3Q12	1854-0215	1		TRANSISTOR NPN SI PD=350MW FT=300MHZ	04713	2N3904
A3R1	1810-0055	5	3	NETWORK-RES 9-SIP10.0K OHM X 8	28480	1810-0055
A3R2	0757-0442	9	40	RESISTOR 10K 1% .125W F TC=0+-100	24546	C4=1/8-T0=1002-F
A3R3	0757-0401	0	27	RESISTOR 100 1% .125W F TC=0+-100	24546	C4=1/8-T0=101-F
A3R4	0757-0412	3	1	RESISTOR 365 1% .125W F TC=0+-100	24546	C4=1/8-T0=365R-F
A3R5	0757-0417	8		RESISTOR 562 1% .125W F TC=0+-100	24546	C4=1/8-T0=562R-F
A3R6	0757-0706	8		RESISTOR 51.1 1% .25W F TC=0+-100	24546	C5=1/4-T0=511-F
A3R7	0757-0280	3		RESISTOR 1K 1% .125W F TC=0+-100	24546	C4=1/8-T0=1001-F
A3R8	0757-0438	3	28	RESISTOR 5.11K 1% .125W F TC=0+-100	24546	C4=1/8-T0=5111-F
A3R9	0698-4458	9	3	RESISTOR 590 1% .125W F TC=0+-100	24546	C4=1/8-T0=590R-F
A3R10	0698-3447	4	3	RESISTOR 422 1% .125W F TC=0+-100	24546	C4=1/8-T0=422R-F
A3R11	0757-0438	3		RESISTOR 5.11K 1% .125W F TC=0+-100	24546	C4=1/8-T0=5111-F
A3R12	0757-0439	4	16	RESISTOR 6.81K 1% .125W F TC=0+-100	24546	C4=1/8-T0=6811-F
A3R13	0757-0444	1	27	RESISTOR 12.1K 1% .125W F TC=0+-100	24546	C4=1/8-T0=1212-F
A3R14	0757-0458	7	14	RESISTOR 51.1K 1% .125W F TC=0+-100	24546	C4=1/8-T0=5112-F
A3R15	0698-3260	9	2	RESISTOR 464K 1% .125W F TC=0+-100	28480	0698-3260
A3R16	0757-0123	3	1	RESISTOR 34.8K 1% .125W F TC=0+-100	28480	0757-0123
A3R18	0757-0291	6	1	RESISTOR 24.9 1% .125W F TC=0+-100	19701	MF4C1/8-T0=2492-F
A3R19	0757-0280	3		RESISTOR 1K 1% .125W F TC=0+-100	24546	C4=1/8-T0=1001-F
A3R20	0757-0280	3		RESISTOR 1K 1% .125W F TC=0+-100	24546	C4=1/8-T0=1001-F
A3R21	0757-0401	0		RESISTOR 100 1% .125W F TC=0+-100	24546	C4=1/8-T0=101-F
A3R22	0757-0465	6	6	RESISTOR 100K 1% .125W F TC=0+-100	24546	C4=1/8-T0=1003-F
A3R23	0698-3447	4		RESISTOR 422 1% .125W F TC=0+-100	24546	C4=1/8-T0=422R-F
A3R24	0757-0465	6		RESISTOR 100K 1% .125W F TC=0+-100	24546	C4=1/8-T0=1003-F
A3R25	0698-4486	3	5	RESISTOR 24.9K 1% .125W F TC=0+-100	24546	C4=1/8-T0=2492-F
A3R26	0757-0283	6	11	RESISTOR 2K 1% .125W F TC=0+-100	24546	C4=1/8-T0=2001-F
A3R27	0698-4486	3		RESISTOR 24.9K 1% .125W F TC=0+-100	24546	C4=1/8-T0=2492-F
A3R28	0698-3178	8	8	RESISTOR 487 1% .125W F TC=0+-100	24546	C4=1/8-T0=487R-F
A3R29	0698-4444	3	6	RESISTOR 4.87K 1% .125W F TC=0+-100	24546	C4=1/8-T0=4871-F
A3R30	0757-0280	3		RESISTOR 1K 1% .125W F TC=0+-100	24546	C4=1/8-T0=1001-F
A3R31	0757-0442	9		RESISTOR 10K 1% .125W F TC=0+-100	24546	C4=1/8-T0=1002-F
A3R32	0698-4086	9	5	RESISTOR 22.6 1% .125W F TC=0+-100	03888	PM55=1/8-T0=22R6-F
A3R33	0757-0346	2	20	RESISTOR 10 1% .125W F TC=0+-100	24546	C4=1/8-T0=10R0-F
A3R34	0698-3178	8		RESISTOR 487 1% .125W F TC=0+-100	24546	C4=1/8-T0=487R-F
A3R35	0698-4444	3		RESISTOR 4.87K 1% .125W F TC=0+-100	24546	C4=1/8-T0=4871-F
A3R36	0757-0280	3		RESISTOR 1K 1% .125W F TC=0+-100	24546	C4=1/8-T0=1001-F
A3R37	0757-0442	9		RESISTOR 10K 1% .125W F TC=0+-100	24546	C4=1/8-T0=1002-F
A3R38	0698-4086	9		RESISTOR 22.6 1% .125W F TC=0+-100	03888	PM55=1/8-T0=22R6-F
A3R39	0757-0346	2		RESISTOR 10 1% .125W F TC=0+-100	24546	C4=1/8-T0=10R0-F
A3R41	0757-0349	5	12	RESISTOR 22.6K 1% .125W F TC=0+-100	24546	C4=1/8-T0=2262-F
A3R42	0757-0438	3		RESISTOR 5.11K 1% .125W F TC=0+-100	24546	C4=1/8-T0=5111-F
A3R43	0757-0283	6		RESISTOR 2K 1% .125W F TC=0+-100	24546	C4=1/8-T0=2001-F
A3R44	0757-0283	6		RESISTOR 2K 1% .125W F TC=0+-100	24546	C4=1/8-T0=2001-F
A3R45	1810-0055	5		NETWORK-RES 9-SIP10.0K OHM X 8	28480	1810-0055
A3R46	0757-0442	9		RESISTOR 10K 1% .125W F TC=0+-100	24546	C4=1/8-T0=1002-F
A3R47	0757-0442	9		RESISTOR 10K 1% .125W F TC=0+-100	24546	C4=1/8-T0=1002-F
A3R48	0757-0450	9	1	RESISTOR 22.1K 1% .125W F TC=0+-100	24546	C4=1/8-T0=2212-F
A3R50	0757-0442	9		RESISTOR 10K 1% .125W F TC=0+-100	24546	C4=1/8-T0=1002-F
A3R51	0757-0465	6		RESISTOR 100K 1% .125W F TC=0+-100	24546	C4=1/8-T0=1003-F
A3R52	0698-4460	3	6	RESISTOR 649 1% .125W F TC=0+-100	24546	C4=1/8-T0=649R-F
A3R53	0757-0472	5	1	RESISTOR 200K 1% .125W F TC=0+-100	24546	C4=1/8-T0=2003-F
A3R55	0698-4460	3		RESISTOR 649 1% .125W F TC=0+-100	24546	C4=1/8-T0=649R-F
A3R56	0698-4460	3		RESISTOR 649 1% .125W F TC=0+-100	24546	C4=1/8-T0=649R-F
A3R57	0698-4460	3		RESISTOR 649 1% .125W F TC=0+-100	24546	C4=1/8-T0=649R-F
A3R58	0698-4460	3		RESISTOR 649 1% .125W F TC=0+-100	24546	C4=1/8-T0=649R-F
A3R59	0698-4460	3		RESISTOR 649 1% .125W F TC=0+-100	24546	C4=1/8-T0=649R-F

Table 6-3. Replaceable Parts (cont'd)

Reference Designation	HP Part Number	C D	Qty	Description	Mfr Code	Mfr Part Number
A3R60	1810-0055	5		NETWORK-RES 9-SIP10.0K OHM X R	28480	1810-0055
A3R61	0757-0493	0	8	RESISTOR 15 1% .25W F TC0+/-100	19701	MF52C1/4-T0=15R0-F
A3R62	0757-0493	0		RESISTOR 15 1% .25W F TC0+/-100	19701	MF52C1/4-T0=15R0-F
A3R63	0757-0493	0		RESISTOR 15 1% .25W F TC0+/-100	19701	MF52C1/4-T0=15R0-F
A3R64	0757-0493	0		RESISTOR 15 1% .25W F TC0+/-100	19701	MF52C1/4-T0=15R0-F
A3R65	0757-0493	0		RESISTOR 15 1% .25W F TC0+/-100	19701	MF52C1/4-T0=15R0-F
A3R66	0757-0493	0		RESISTOR 15 1% .25W F TC0+/-100	19701	MF52C1/4-T0=15R0-F
A3R67	0757-0493	0		RESISTOR 15 1% .25W F TC0+/-100	19701	MF52C1/4-T0=15R0-F
A3R68	0757-0493	0		RESISTOR 15 1% .25W F TC0+/-100	19701	MF52C1/4-T0=15R0-F
A3R70	1810-0041	9	3	NETWORK-RES 9-SIP2.7K OHM X B	28480	1810-0041
A3R71	0698-3439	4	13	RESISTOR 178 1% .125W F TC0+/-100	24546	C4-1/8-T0=178R-F
A3R72	0698-3439	4		RESISTOR 178 1% .125W F TC0+/-100	24546	C4-1/8-T0=178R-F
A3R73	0698-3439	4		RESISTOR 178 1% .125W F TC0+/-100	24546	C4-1/8-T0=178R-F
A3R74	0698-3439	4		RESISTOR 178 1% .125W F TC0+/-100	24546	C4-1/8-T0=178R-F
A3R75	0698-3439	4		RESISTOR 178 1% .125W F TC0+/-100	24546	C4-1/8-T0=178R-F
A3R76	0698-3439	4		RESISTOR 178 1% .125W F TC0+/-100	24546	C4-1/8-T0=178R-F
A3R77	0698-3439	4		RESISTOR 178 1% .125W F TC0+/-100	24546	C4-1/8-T0=178R-F
A3R78	0698-3439	4		RESISTOR 178 1% .125W F TC0+/-100	24546	C4-1/8-T0=178R-F
A3R79	1810-0041	9		NETWORK-RES 9-SIP2.7K OHM X B	28480	1810-0041
A3R80	1810-0041	9		NETWORK-RES 9-SIP2.7K OHM X B	28480	1810-0041
A3R81	0698-3439	4		RESISTOR 178 1% .125W F TC0+/-100	24546	C4-1/8-T0=178R-F
A3R82	0698-3439	4		RESISTOR 178 1% .125W F TC0+/-100	24546	C4-1/8-T0=178R-F
A3R83	0698-3439	4		RESISTOR 178 1% .125W F TC0+/-100	24546	C4-1/8-T0=178R-F
A3R84	0698-3439	4		RESISTOR 178 1% .125W F TC0+/-100	24546	C4-1/8-T0=178R-F
A3R87	0757-0442	9		RESISTOR 10K 1% .125W F TC0+/-100	24546	C4-1/8-T0=1002-F
A3R88	0683-5645	7	1	RESISTOR 560K 5% .25W FC TC0+/-900	01121	CB5645
A3R90	0757-0384	8	8	RESISTOR 20 1% .125W F TC0+/-100	19701	MF4C1/8-T0=20R0-F
A3R91	0757-0384	8		RESISTOR 20 1% .125W F TC0+/-100	19701	MF4C1/8-T0=20R0-F
A3R92	0757-0384	8		RESISTOR 20 1% .125W F TC0+/-100	19701	MF4C1/8-T0=20R0-F
A3R93	0757-0384	8		RESISTOR 20 1% .125W F TC0+/-100	19701	MF4C1/8-T0=20R0-F
A3R94	0757-0384	8		RESISTOR 20 1% .125W F TC0+/-100	19701	MF4C1/8-T0=20R0-F
A3R95	0757-0384	8		RESISTOR 20 1% .125W F TC0+/-100	19701	MF4C1/8-T0=20R0-F
A3RT1	0837-0050	5	1	THERMISTOR DISC 1K-OHM TC0=-4.4%/C-DEG	28480	0837-0050
A3U1	1820-1491	6	1	IC BFR TTL LS NON-INV HEX 1-INP	01295	SN74LS367AN
A3U2	1820-1217	4	1	IC MUXR/DATA=SEL TTL LS 8-T0=1-LINE	01295	SN74LS151N
A3U3	1820-1481	4	3	IC NMOS	04713	MC6821L
A3U4	1820-1201	6	2	IC GATE TTL LS AND QUAD 2-INP	01295	SN74LS08N
A3U5	1820-1201	6		IC GATE TTL LS AND QUAD 2-INP	01295	SN74LS08N
A3U6	1820-1445	0	8	IC LCH TTL LS 4-BIT	01295	SN74LS375N
A3U7	1820-1445	0		IC LCH TTL LS 4-BIT	01295	SN74LS375N
A3U8	1820-1445	0		IC LCH TTL LS 4-BIT	01295	SN74LS375N
A3U9	1820-1445	0		IC LCH TTL LS 4-BIT	01295	SN74LS375N
A3U10	1820-1445	0		IC LCH TTL LS 4-BIT	01295	SN74LS375N
A3U11	1820-1423	4	3	IC MV TTL LS MONOSTBL RETRIG DUAL	01295	SN74LS123N
A3U12	1820-1804	5	1	IC BFR NMOS CLOCK DRVR	04713	MP06842
A3U13	1820-1480	3	1	IC MICPROC NMOS 8-BIT	04713	MC6800L
A3U14	1820-1199	1	4	IC INV TTL LS HEX 1-INP	01295	SN74LS04N
A3U15	1820-1281	2	2	IC DCDR TTL LS 2-T0=4-LINE DUAL 2-INP	01295	SN74LS139N
A3U16	1820-1199	1		IC INV TTL LS HEX 1-INP	01295	SN74LS04N
A3U17	1820-1208	3	2	IC GATE TTL LS OR QUAD 2-INP	01295	SN74LS32N
A3U18	1820-1144	6	3	IC GATE TTL LS NOR QUAD 2-INP	01295	SN74LS02N
A3U19	1820-1425	6	1	IC SCHMITT-TRIG TTL LS NAND QUAD 2-INP	01295	SN74LS132N
A3U20	1818-0319	0	3	IC CMOS 1K RAM STAT 650-NS 3-S	34649	P5101L=3
A3U21	1818-0319	0		IC CMOS 1K RAM STAT 650-NS 3-S	34649	P5101L=3
A3U22	1818-0319	0		IC CMOS 1K RAM STAT 650-NS 3-S	34649	P5101L=3
A3U23	1818-0364	5	1	IC NMOS 16384-BIT ROM 550-NS 3-S	04713	MC6832L PROGRAMMED
A3U24	1818-0362	3	1	IC NMOS 16384-BIT ROM 550-NS 3-S	04713	MC6832L PROGRAMMED
A3U25	1818-0363	4	1	IC NMOS 16384-BIT ROM 550-NS 3-S	04713	MC6832L PROGRAMMED
A3U26	1818-0361	2	1	IC NMOS 16384-BIT ROM 550-NS 3-S	04713	MC6832L PROGRAMMED
A3U27	1820-1423	4		IC MV TTL LS MONOSTBL RETRIG DUAL	01295	SN74LS123N
A3U28	1820-1746	4	3	IC BFR CMOS INV HEX	04713	MC14049UBCP
A3U29	1820-1199	1		IC INV TTL LS HEX 1-INP	01295	SN74LS04N
A3U30	1820-1266	3	1	IC BFR CMOS NON-INV HEX	07263	40097PC
A3U31	1820-1144	6		IC GATE TTL LS NOR QUAD 2-INP	01295	SN74LS02N
A3U32	1820-1194	6	1	IC CNTR TTL LS BIN UP/DOWN SYNCHRO	01295	SN74LS193N
A3U33	1820-1418	7	1	IC DCDR TTL LS BCD-T0=DEC 4-T0=10-LINE	01295	SN74LS42N
A3U34	1820-1746	4		IC BFR CMOS INV HEX	04713	MC14049UBCP
A3U35	1820-1197	9	13	IC GATE TTL LS NAND QUAD 2-INP	01295	SN74LS00N
A3U36	1820-0628	9		IC TTL 64-BIT RAM 60-NS 0-C	01295	SN7489N
A3U37	1820-0628	9		IC TTL 64-BIT RAM 60-NS 0-C	01295	SN7489N
A3U38	1820-1644	7	1	IC DCDR TTL LS BCD-T0=7-SEG 4-T0=7-LINE	01295	SN74LS246N
A3U39	1858-0023	1	1	TRANSISTOR ARRAY	01928	CA3081E
A3U40	1820-0445	8	1	IC DCDR TTL 4-T0=16-LINE 4-INP	01295	SN74LS4N

Table 6--3. Replaceable Parts (cont'd)

Reference Designation	HP Part Number	C D	Qty	Description	Mfr Code	Mfr Part Number
A3U41	1858-0014	6	3	TRANSISTOR ARRAY	28480	1858-0014
A3U42	185A-0014	6		TRANSISTOR ARRAY	28480	1858-0014
A3U43	1858-0014	6		TRANSISTOR ARRAY	28480	1858-0014
A3U44	1820-1445	0		IC LCH TTL LS 4-BIT	01295	SN74LS375N
A3U45	1820-1445	0		IC LCH TTL LS 4-BIT	01295	SN74LS375N
A3U46	1820-1445	0		IC LCH TTL LS 4-BIT	01295	SN74LS375N
A3U47	1820-1197	9		IC GATE TTL LS NAND QUAD 2-INP	01295	SN74LS00N
A3U48	1820-1281	2		IC DCDR TTL LS 2-TC-4-LINE DUAL 2-INP	01295	SN74LS139N
A3U49	1820-1451	8	6	IC GATE TTL S NAND QUAD 2-INP	01295	SN74838N
A3U50	1820-1451	8		IC GATE TTL S NAND QUAD 2-INP	01295	SN74838N
A3U51	1820-1197	9		IC GATE TTL LS NAND QUAD 2-INP	01295	SN74LS00N
A3U52	1820-1197	9		IC GATE TTL LS NAND QUAD 2-INP	01295	SN74LS00N
A3U53	1820-1197	9		IC GATE TTL LS NAND QUAD 2-INP	01295	SN74LS00N
A3U54	1820-1451	8		IC GATE TTL S NAND QUAD 2-INP	01295	SN74838N
A3U55	1820-1451	8		IC GATE TTL S NAND QUAD 2-INP	01295	SN74838N
A3U56	1820-1451	8		IC GATE TTL S NAND QUAD 2-INP	01295	SN74838N
A3VR1	1902-3188	6	3	DIODE-ZNR 12.7V 2% DO-7 PD=.4W TC=+.061%	28480	1902-3188
A3VR2	1902-0048	1	3	DIODE-ZNR 6.81V 5% DO-7 PD=.4W TC=+.043%	28480	1902-0048
A4	08165-66504	7	1	BOARD ASSEMBLY, OUTPUT AMPLIFIER	28480	08165-66504
A4C1	0180-2837	7	1	CAPACITOR-FXD .032F+75-10% 20VDC AL	28480	0180-2837
A4C2	0180-2240	6	1	CAPACITOR-FXD 2400UF+75-10% 25VDC AL	56289	3902486025JL6-058
A4C3	0180-0677	9	2	CAPACITOR-FXD 5800UF+75-10% 40VDC AL	28480	0180-0677
A4C4	0180-0677	9		CAPACITOR-FXD 5800UF+75-10% 40VDC AL	28480	0180-0677
A4C5	0160-3731	0	6	CAPACITOR-FXD .01UF +-20% 1KVDC CER	28480	0160-3731
A4C6	0160-3731	0		CAPACITOR-FXD .01UF +-20% 1KVDC CER	28480	0160-3731
A4C7	0160-3731	0		CAPACITOR-FXD .01UF +-20% 1KVDC CER	28480	0160-3731
A4C8	0160-3731	0		CAPACITOR-FXD .01UF +-20% 1KVDC CER	28480	0160-3731
A4C9	0160-3731	0		CAPACITOR-FXD .01UF +-20% 1KVDC CER	28480	0160-3731
A4C10	0160-3731	0		CAPACITOR-FXD .01UF +-20% 1KVDC CER	28480	0160-3731
A4C11	0180-0228	6		CAPACITOR-FXD 22UF+-10% 15VDC TA	56289	150D226X901582
A4C101	0160-3879	7	40	CAPACITOR-FXD .01UF +-20% 100VDC CER	28480	0160-3879
A4C102	0160-3879	7		CAPACITOR-FXD .01UF +-20% 100VDC CER	28480	0160-3879
A4C103	0160-2306	3	1	CAPACITOR-FXD 27PF +-5% 300VDC MICA	28480	0160-2306
A4C104	0160-0573	2	2	CAPACITOR-FXD 4700PF +-20% 100VDC CER	28480	0160-0573
A4C105	0160-0134	1	2	CAPACITOR-FXD 220PF +-5% 300VDC MICA	28480	0160-0134
A4C106	0121-0475	1	4	CAPACITOR-V TRMR-POLYP 2-22PF 100V	02540	222 808 11229
A4C107	0160-0174	9		CAPACITOR-FXD .47UF +80-20% 25VDC CER	28480	0160-0174
A4C109	0160-0570	9	2	CAPACITOR-FXD 220PF +-20% 100VDC CER	20932	5024EM100RD221K
A4C110	0160-0576	5	20	CAPACITOR-FXD .1UF +-20% 50VDC CER	28480	0160-0576
A4C111	0160-0174	9		CAPACITOR-FXD .47UF +80-20% 25VDC CER	28480	0160-0174
A4C112	0160-0174	9		CAPACITOR-FXD .47UF +80-20% 25VDC CER	28480	0160-0174
A4C113	0160-3879	7		CAPACITOR-FXD .01UF +-20% 100VDC CER	28480	0160-3879
A4C114	0160-3879	7		CAPACITOR-FXD .01UF +-20% 100VDC CER	28480	0160-3879
A4C115	0160-0576	5		CAPACITOR-FXD .1UF +-20% 50VDC CER	28480	0160-0576
A4C117	0160-3873	1	4	CAPACITOR-FXD 4.7PF +-5PF 200VDC CER	28480	0160-3873
A4C118	0160-0576	5		CAPACITOR-FXD .1UF +-20% 50VDC CER	28480	0160-0576
A4C119*	0160-3872	0	1	CAPACITOR-FXD 2.2PF +-25PF 200VDC CER	28480	0160-3872
A4C120	0160-3873	1		CAPACITOR-FXD 4.7PF +-5PF 200VDC CER	28480	0160-3873
A4C121	0160-3878	6	9	CAPACITOR-FXD 1000PF +-20% 100VDC CER	28480	0160-3878
A4C122	0160-0571	0	1	CAPACITOR-FXD 470PF +-20% 100VDC CER	28480	0160-0571
A4C123	0160-0127	2	1	CAPACITOR-FXD 1UF +-20% 25VDC CER	28480	0160-0127
A4C124	0160-4386	3	1	CAPACITOR-FXD 33PF +-5% 200VDC CER 0+-30	51642	200-200-NP0-330J
A4C201	0160-0576	5		CAPACITOR-FXD .1UF +-20% 50VDC CER	28480	0160-0576
A4C202	0160-0128	3	4	CAPACITOR-FXD 2.2UF +-20% 50VDC CER	28480	0160-0128
A4C203	0180-1704	5		CAPACITOR-FXD 47UF+-10% 6VDC TA	56289	150D476X900682
A4C204	0160-3879	7		CAPACITOR-FXD .01UF +-20% 100VDC CER	28480	0160-3879
A4C205	0160-3879	7		CAPACITOR-FXD .01UF +-20% 100VDC CER	28480	0160-3879
A4C206	0160-0174	9		CAPACITOR-FXD .47UF +80-20% 25VDC CER	28480	0160-0174
A4C207	0160-3879	7		CAPACITOR-FXD .01UF +-20% 100VDC CER	28480	0160-3879
A4C208	0160-0576	5		CAPACITOR-FXD .1UF +-20% 50VDC CER	28480	0160-0576
A4C209	0160-0128	3		CAPACITOR-FXD 2.2UF +-20% 50VDC CER	28480	0160-0128
A4C210	0180-1704	5		CAPACITOR-FXD 47UF+-10% 6VDC TA	56289	150D476X900682
A4C211	0160-3879	7		CAPACITOR-FXD .01UF +-20% 100VDC CER	28480	0160-3879
A4C212	0160-4210	2		CAPACITOR-FXD .022UF +-20% 50VDC POLYE	28480	0160-4210
A4C213	0160-3879	7		CAPACITOR-FXD .01UF +-20% 100VDC CER	28480	0160-3879
A4C214	0160-0174	9		CAPACITOR-FXD .47UF +80-20% 25VDC CER	28480	0160-0174
A4C301	0160-3879	7		CAPACITOR-FXD .01UF +-20% 100VDC CER	28480	0160-3879
A4C302	0160-0575	4	1	CAPACITOR-FXD .047UF +-20% 50VDC CER	28480	0160-0575
A4C303	0160-3879	7		CAPACITOR-FXD .01UF +-20% 100VDC CER	28480	0160-3879
A4C304	0160-3879	7		CAPACITOR-FXD .01UF +-20% 100VDC CER	28480	0160-3879
A4C305	0160-3879	7		CAPACITOR-FXD .01UF +-20% 100VDC CER	28480	0160-3879
A4C501	0160-0576	5		CAPACITOR-FXD .1UF +-20% 50VDC CER	28480	0160-0576
A4C502	0160-3879	7		CAPACITOR-FXD .01UF +-20% 100VDC CER	28480	0160-3879
A4C503	0160-3879	7		CAPACITOR-FXD .01UF +-20% 100VDC CER	28480	0160-3879

Table 6-3. Replaceable Parts (cont'd)

Reference Designation	HP Part Number	C D	Qty	Description	Mfr Code	Mfr Part Number
A4C504	0180-1743	2	1	CAPACITOR-FXD .1UF+-10% 35VDC TA	56289	150D104X9035A2
A4C505	0180-0197	8		CAPACITOR-FXD 2.2UF+-10% 20VDC TA	56289	150D225X9020A2
A4C506	0160-4209	9	16	CAPACITOR-FXD .01UF +-20% 50VDC POLYE	28480	0160-4209
A4C508	0160-4209	9		CAPACITOR-FXD .01UF +-20% 50VDC POLYE	28480	0160-4209
A4C509	0160-3879	7		CAPACITOR-FXD .01UF +-20% 100VDC CER	28480	0160-3879
A4C510	0160-4209	9		CAPACITOR-FXD .01UF +-20% 50VDC POLYE	28480	0160-4209
A4C511	0121-0475	1		CAPACITOR-V TRMR-POLYP 2-22PF 100V	02540	2222 808 11229
A4C512	0121-0475	1		CAPACITOR-V TRMR-POLYP 2-22PF 100V	02540	2222 808 11229
A4C513	0121-0475	1		CAPACITOR-V TRMR-POLYP 2-22PF 100V	02540	2222 808 11229
A4CR1	1901-0731	7	5	DIODE-PWR RECT 400V 1A	28480	1901-0731
A4CR2	1901-0731	7		DIODE-PWR RECT 400V 1A	28480	1901-0731
A4CR3	1901-0522	4	4	DIODE-GEN PRP 200V 3A 2US	28480	1901-0522
A4CR4	1901-0522	4		DIODE-GEN PRP 200V 3A 2US	28480	1901-0522
A4CR5	1901-0522	4		DIODE-GEN PRP 200V 3A 2US	28480	1901-0522
A4CR6	1901-0522	4		DIODE-GEN PRP 200V 3A 2US	28480	1901-0522
A4CR7	1901-0731	7		DIODE-PWR RECT 400V 1A	28480	1901-0731
A4CR8	1901-0731	7		DIODE-PWR RECT 400V 1A	28480	1901-0731
A4CR101	1901-0460	9	3	DIODE-STABISTOR 30V 150MA DO-7	28480	1901-0460
A4CR201	1901-0050	3		DIODE-SWITCHING 80V 200MA 2NS DO-35	28480	1901-0050
A4CR203	1901-0620	3	2	DIODE-SWITCHING 80V 400MA DO-35	0004G	NDP250
A4CR204	1901-0050	3		DIODE-SWITCHING 80V 200MA 2NS DO-35	28480	1901-0050
A4CR206	1901-0620	3		DIODE-SWITCHING 80V 400MA DO-35	0004G	NDP250
A4CR301	1901-0050	3		DIODE-SWITCHING 80V 200MA 2NS DO-35	28480	1901-0050
A4CR302	1901-0460	9		DIODE-STABISTOR 30V 150MA DO-7	28480	1901-0460
A4CR304	1901-0050	3		DIODE-SWITCHING 80V 200MA 2NS DO-35	28480	1901-0050
A4CR305	1901-0460	9		DIODE-STABISTOR 30V 150MA DO-7	28480	1901-0460
A4CR501	1901-0040	1	5A	DIODE-SWITCHING 30V 50MA 2NS DO-35	28480	1901-0040
A4CR502	1901-0040	1		DIODE-SWITCHING 30V 50MA 2NS DO-35	28480	1901-0040
A4CR503	1901-0040	1		DIODE-SWITCHING 30V 50MA 2NS DO-35	28480	1901-0040
A4CR504	1901-0040	1		DIODE-SWITCHING 30V 50MA 2NS DO-35	28480	1901-0040
A4CR505	1901-0040	1		DIODE-SWITCHING 30V 50MA 2NS DO-35	28480	1901-0040
A4CR506	1901-0040	1		DIODE-SWITCHING 30V 50MA 2NS DO-35	28480	1901-0040
A4J1	1200-0814	1	5	SOCKET-XSTR 3-CONT DIP-SLDR	28480	1200-0814
A4J2	1200-0814	1		SOCKET-XSTR 3-CONT DIP-SLDR	28480	1200-0814
A4J3	1200-0814	1		SOCKET-XSTR 3-CONT DIP-SLDR	28480	1200-0814
A4J4	1200-0814	1		SOCKET-XSTR 3-CONT DIP-SLDR	28480	1200-0814
A4J5	1200-0814	1		SOCKET-XSTR 3-CONT DIP-SLDR	28480	1200-0814
A4J7	1251-3785	8	1	CONNECTOR 20-PIN F METRIC CIS	28480	1251-3785
A4J8	1251-3708	5	1	CONNECTOR 10-PIN F METRIC CIS	28480	1251-3708
A4J9	1251-1365	6	1	CONNECTOR-PC EDGE 22-CONT/ROW 2-ROWS	28480	1251-1365
A4J10	1251-1626	2	1	CONNECTOR-PC EDGE 12-CONT/ROW 2-ROWS	28480	1251-1626
A4J12	1251-0472	4	1	CONNECTOR-PC EDGE 6-CONT/ROW 2-ROWS	28480	1251-0472
A4K101	0490-1034	1	2	RELAY 2C 12VDC-COIL .5A 350VDC	28480	0490-1034
A4K102	0490-1079	4	14	RELAY-REED 1A 500MA 100VDC 5VDC-COIL	28480	0490-1079
A4K401	0490-1079	4		RELAY-REED 1A 500MA 100VDC 5VDC-COIL	28480	0490-1079
A4K402	0490-1079	4		RELAY-REED 1A 500MA 100VDC 5VDC-COIL	28480	0490-1079
A4K403	0490-1079	4		RELAY-REED 1A 500MA 100VDC 5VDC-COIL	28480	0490-1079
A4K404	0490-0617	4	3	RELAY-REED 1C 250MA 28VDC 5VDC-COIL	28480	0490-0617
A4K405	0490-1034	1		RELAY 2C 12VDC-COIL .5A 350VDC	28480	0490-1034
A4L101	5081-1973	5	10	INDUCTANCE, 3-BEAD	28480	5081-1973
A4L102	5081-1973	5		INDUCTANCE, 3-BEAD	28480	5081-1973
A4L103	5081-1973	5		INDUCTANCE, 3-BEAD	28480	5081-1973
A4L104	9170-0029	3	16	CORE-SHIELDING BEAD	28480	9170-0029
A4L201	5081-1973	5		INDUCTANCE, 3-BEAD	28480	5081-1973
A4L202	5081-1973	5		INDUCTANCE, 3-BEAD	28480	5081-1973
A4L203	9170-0029	3		CORE-SHIELDING BEAD	28480	9170-0029
A4L204	9170-0029	3		CORE-SHIELDING BEAD	28480	9170-0029
A4L205	9170-0029	3		CORE-SHIELDING BEAD	28480	9170-0029
A4L206	9170-0029	3		CORE-SHIELDING BEAD	28480	9170-0029
A4L301	5081-1973	5		INDUCTANCE, 3-BEAD	28480	5081-1973
A4L302	5081-1973	5		INDUCTANCE, 3-BEAD	28480	5081-1973
A4MP1	08165-03201	9	1	COUPLER, THERMAL	28480	08165-03201
A4MP2	08165-01101	4	1	HEAT SINK, OUTPUT AMPLIFIER	28480	08165-01101
A4MP3	1205-0236	1	1	HEAT SINK (MISC ITEM)	28480	1205-0236
A4MP4	08165-00602	8	1	SHIELD, ATTENUATOR	28480	08165-00602
A4Q101	1853-0315	0	6	TRANSISTOR PNP SI TO-39 PDIW FT=1GHZ	28480	1853-0315
A4Q102	1853-0315	0		TRANSISTOR PNP SI TO-39 PDIW FT=1GHZ	28480	1853-0315
A4Q103	1854-0477	7		TRANSISTOR NPN 2N2222A SI TO-18 PD=500MW	04713	2N2222A
A4Q104	1854-0477	7		TRANSISTOR NPN 2N2222A SI TO-18 PD=500MW	04713	2N2222A
A4Q105	1854-0477	7		TRANSISTOR NPN 2N2222A SI TO-18 PD=500MW	04713	2N2222A
A4Q106	1853-0086	2		TRANSISTOR PNP SI PD=310MW FT=40MHZ	27014	2N5087
A4Q107	5081-1978	0	2	TRANSISTOR, MATCHES PAIR	28480	5081-1978
A4Q108	5081-1978	0		TRANSISTOR, MATCHES PAIR	28480	5081-1978
A4Q111	1854-0366	5	1	TRANSISTOR NPN 2N5191 SI PD=40W FT=2MHZ	04713	2N5191
A4Q201	1854-0498	2	2	TRANSISTOR NPN SI TO-39 PDIW	28480	1854-0498

Table 6-3. Replaceable Parts (cont'd)

Reference Designation	HP Part Number	C D	Qty	Description	Mfr Code	Mfr Part Number
A4Q202	1853-0314	9	A	TRANSISTOR PNP 2N2905A SI TO-39 PD=600MW	04713	2N2905A
A4Q203	1853-0315	0		TRANSISTOR PNP SI TO-39 PD=1W FT=1GHZ	28480	1853-0315
A4Q204	1853-0315	0		TRANSISTOR PNP SI TO-39 PD=1W FT=1GHZ	28480	1853-0315
A4Q205	1854-0637	1	7	TRANSISTOR NPN 2N2219A SI TO-5 PD=800MW	01295	2N2219A
A4Q206	1854-0332	3	2	TRANSISTOR NPN SI TO-39 PD=1W FT=800MHZ	28480	1854-0332
A4Q207	1853-0281	9	9	TRANSISTOR PNP 2N2907A SI TO-18 PD=400MW	04713	2N2907A
A4Q208	1854-0392	5		TRANSISTOR NPN SI PD=310MW FT=50MHZ	04713	2N5088
A4Q209	1853-0036	2		TRANSISTOR PNP SI PD=310MW FT=250MHZ	28480	1853-0036
A4Q210	1854-0477	7		TRANSISTOR NPN 2N2222A SI TO-18 PD=500MW	04713	2N2222A
A4Q301	1854-0498	2		TRANSISTOR NPN SI TO-39 PD=1W	28480	1854-0498
A4Q302	1853-0314	9		TRANSISTOR PNP 2N2905A SI TO-39 PD=600MW	04713	2N2905A
A4Q303	1853-0315	0		TRANSISTOR PNP SI TO-39 PD=1W FT=1GHZ	28480	1853-0315
A4Q304	1853-0315	0		TRANSISTOR PNP SI TO-39 PD=1W FT=1GHZ	28480	1853-0315
A4Q305	1854-0637	1		TRANSISTOR NPN 2N2219A SI TO-5 PD=800MW	01295	2N2219A
A4Q306	1854-0332	3		TRANSISTOR NPN SI TO-39 PD=1W FT=800MHZ	28480	1854-0332
A4Q307	1853-0314	9		TRANSISTOR PNP 2N2905A SI TO-39 PD=600MW	04713	2N2905A
A4Q308	1854-0392	5		TRANSISTOR NPN SI PD=310MW FT=50MHZ	04713	2N5088
A4Q309	1853-0036	2		TRANSISTOR PNP SI PD=310MW FT=250MHZ	28480	1853-0036
A4Q310	1854-0637	1		TRANSISTOR NPN 2N2219A SI TO-5 PD=800MW	01295	2N2219A
A4Q501	1854-0215	1		TRANSISTOR NPN SI PD=350MW FT=300MHZ	04713	2N3904
A4Q502	1853-0086	2		TRANSISTOR PNP SI PD=310MW FT=40MHZ	27014	2N5087
A4Q503	1854-0392	5		TRANSISTOR NPN SI PD=310MW FT=50MHZ	04713	2N5088
A4Q504	1854-0392	5		TRANSISTOR NPN SI PD=310MW FT=50MHZ	04713	2N5088
A4Q505	1853-0086	2		TRANSISTOR PNP SI PD=310MW FT=40MHZ	27014	2N5087
A4Q506	1853-0086	2		TRANSISTOR PNP SI PD=310MW FT=40MHZ	27014	2N5087
A4Q507	1854-0215	1		TRANSISTOR NPN SI PD=350MW FT=300MHZ	04713	2N3904
A4Q508	1853-0086	2		TRANSISTOR PNP SI PD=310MW FT=40MHZ	27014	2N5087
A4Q509	1854-0215	1		TRANSISTOR NPN SI PD=350MW FT=300MHZ	04713	2N3904
A4Q510	1854-0215	1		TRANSISTOR NPN SI PD=350MW FT=300MHZ	04713	2N3904
A4R1	0757-0706	8		RESISTOR 51.1 1% .25W F TC=0+-100	24546	C5=1/4-T0=51R1=F
A4R2	0811-1827	2	2	RESISTOR 1.1 10% 3W PW TC=0+-90	28480	0811-1827
A4R3	0757-0706	8		RESISTOR 51.1 1% .25W F TC=0+-100	24546	C5=1/4-T0=51R1=F
A4R4	0812-0040	1	1	RESISTOR .27 5% .5W PW TC=0+-300	75042	RN20=1/2-27/100-J
A4R5	0757-0407	6	21	RESISTOR 200 1% .125W F TC=0+-100	24546	C4=1/8-T0=201=F
A4R6	0812-0045	6	2	RESISTOR .15 5% 3W PW TC=0+-90	28480	0812-0045
A4R7	0757-0407	6		RESISTOR 200 1% .125W F TC=0+-100	24546	C4=1/8-T0=201=F
A4R8	0812-0045	6		RESISTOR .15 5% 3W PW TC=0+-90	28480	0812-0045
A4R9	0811-1827	2		RESISTOR 1.1 10% 3W PW TC=0+-90	28480	0811-1827
A4R10	0757-0407	6		RESISTOR 200 1% .125W F TC=0+-100	24546	C4=1/8-T0=201=F
A4R101	0757-0394	0	24	RESISTOR 51.1 1% .125W F TC=0+-100	24546	C4=1/8-T0=51R1=F
A4R102	0757-0346	2		RESISTOR 10 1% .125W F TC=0+-100	24546	C4=1/8-T0=10R0=F
A4R103	0757-0394	0		RESISTOR 51.1 1% .125W F TC=0+-100	24546	C4=1/8-T0=51R1=F
A4R104	0757-0346	2		RESISTOR 10 1% .125W F TC=0+-100	24546	C4=1/8-T0=10R0=F
A4R105	0757-0796	6	2	RESISTOR 82.5 1% .5W F TC=0+-100	28480	0757-0796
A4R106	0757-0796	6		RESISTOR 82.5 1% .5W F TC=0+-100	28480	0757-0796
A4R107	0757-0499	6	1	RESISTOR 27.4 1% .25W F TC=0+-100	19701	MF52C1/4-T0=27R4=F
A4R108	0698-4086	9		RESISTOR 22.6 1% .125W F TC=0+-100	03888	PM55=1/8-T0=22R6=F
A4R109	0698-4086	9		RESISTOR 22.6 1% .125W F TC=0+-100	03888	PM55=1/8-T0=22R6=F
A4R110	0757-0199	3	7	RESISTOR 21.5K 1% .125W F TC=0+-100	24546	C4=1/8-T0=2152=F
A4R111	2100-2030	6	1	RESISTOR-TRMR 20K 10% C TOP-ADJ 1-TRN	73138	82PR20K
A4R112	0757-1094	9	14	RESISTOR 1.47K 1% .125W F TC=0+-100	24546	C4=1/8-T0=1471=F
A4R113	0757-0200	7	3	RESISTOR 5.62K 1% .125W F TC=0+-100	24546	C4=1/8-T0=5621=F
A4R114	0698-3558	8	9	RESISTOR 4.02K 1% .125W F TC=0+-100	24546	C4=1/8-T0=4021=F
A4R115	2100-2061	3	5	RESISTOR-TRMR 200 10% C TOP-ADJ 1-TRN	73138	82PR200
A4R116	0757-0706	8		RESISTOR 51.1 1% .25W F TC=0+-100	24546	C5=1/4-T0=51R1=F
A4R117	0757-0995	7	1	RESISTOR 33.2 1% .5W F TC=0+-100	28480	0757-0995
A4R118	0757-0706	8		RESISTOR 51.1 1% .25W F TC=0+-100	24546	C5=1/4-T0=51R1=F
A4R119	0698-4425	0	7	RESISTOR 1.54K 1% .125W F TC=0+-100	24546	C4=1/8-T0=1541=F
A4R120	0698-4425	0		RESISTOR 1.54K 1% .125W F TC=0+-100	24546	C4=1/8-T0=1541=F
A4R121	0757-0280	3		RESISTOR 1K 1% .125W F TC=0+-100	24546	C4=1/8-T0=1001=F
A4R122	0757-0401	0		RESISTOR 100 1% .125W F TC=0+-100	24546	C4=1/8-T0=101=F
A4R123	0757-0387	1	1	RESISTOR 27.4 1% .125W F TC=0+-100	19701	MF4C1/8-T0=27R4=F
A4R124	0698-5418	3	4	RESISTOR 50 .1% .125W F TC=0+-50	28480	0698-5418
A4R125	0698-5418	3		RESISTOR 50 .1% .125W F TC=0+-50	28480	0698-5418
A4R126	0698-7205	0	6	RESISTOR 51.1 1% .05W F TC=0+-100	24546	C3=1/8-T00=51R1=G
A4R127	0757-0401	0		RESISTOR 100 1% .125W F TC=0+-100	24546	C4=1/8-T0=101=F
A4R128	0757-0180	2	1	RESISTOR 31.6 1% .125W F TC=0+-100	28480	0757-0180
A4R129	0698-5418	3		RESISTOR 50 .1% .125W F TC=0+-50	28480	0698-5418
A4R130	0698-5418	3		RESISTOR 50 .1% .125W F TC=0+-50	28480	0698-5418
A4R131	0698-7205	0		RESISTOR 51.1 1% .05W F TC=0+-100	24546	C3=1/8-T00=51R1=G
A4R132	0757-0401	0		RESISTOR 100 1% .125W F TC=0+-100	24546	C4=1/8-T0=101=F
A4R133	0757-0276	7	1	RESISTOR 61.9 1% .125W F TC=0+-100	24546	C4=1/8-T0=6192=F
A4R134	0698-4343	1	2	RESISTOR 100 .1% .125W F TC=0+-50	28480	0698-4343
A4R135	0698-4343	1		RESISTOR 100 .1% .125W F TC=0+-50	28480	0698-4343

Table 6-3. Replaceable Parts (cont'd)

Reference Designation	HP Part Number	C D	Qty	Description	Mfr Code	Mfr Part Number
A4R136	0698-7205	0		RESISTOR 51.1 1% .05W F TC0+/-100	24546	C4-1/8-T00-51R1-G
A4R138	0757-0273	4	4	RESISTOR 3.01K 1% .125W F TC0+/-100	24546	C4-1/8-T0-3011-F
A4R139	0757-0283	6		RESISTOR 2K 1% .125W F TC0+/-100	24546	C4-1/8-T0-2001-F
A4R140	0757-0418	9	3	RESISTOR 619 1% .125W F TC0+/-100	24546	C4-1/8-T0-619R-F
A4R141	0698-5174	8	2	RESISTOR 200 5% .125W CC TC0=330/+800	01121	RR2015
A4R142	0698-5174	6		RESISTOR 200 5% .125W CC TC0=330/+800	01121	RR2015
A4R144	0698-3113	1	1	RESISTOR 100 5% .125W CC TC0=270/+540	01121	RA1015
A4R151	0757-0199	3		RESISTOR 21.5K 1% .125W F TC0+/-100	24546	C4-1/8-T0-2152-F
A4R152	0757-0199	3		RESISTOR 21.5K 1% .125W F TC0+/-100	24546	C4-1/8-T0-2152-F
A4R153	0698-0084	9	1	RESISTOR 2.15K 1% .125W F TC0+/-100	24546	C4-1/8-T0-2151-F
A4R154	0757-0273	4		RESISTOR 3.01K 1% .125W F TC0+/-100	24546	C4-1/8-T0-3011-F
A4R155	0757-0401	0		RESISTOR 100 1% .125W F TC0+/-100	24546	C4-1/8-T0-101-F
A4R156	0757-1001	8	7	RESISTOR 56.2 1% .5W F TC0+/-100	28480	0757-1001
A4R157	0757-1001	8		RESISTOR 56.2 1% .5W F TC0+/-100	28480	0757-1001
A4R158	0757-0280	3		RESISTOR 1K 1% .125W F TC0+/-100	24546	C4-1/8-T0-1001-F
A4R159	0757-0280	3		RESISTOR 1K 1% .125W F TC0+/-100	24546	C4-1/8-T0-1001-F
A4R160	0698-3442	0	3	RESISTOR 237 1% .125W F TC0+/-100	24546	C4-1/8-T0-237R-F
A4R161	2100-2061	3		RESISTOR-TRMR 200 10% C TOP=ADJ 1-TRM	73138	R2PR200
A4R162	0698-3132	0	4	RESISTOR 261 1% .125W F TC0+/-100	24546	C4-1/8-T0-2610-F
A4R201	0757-0346	2		RESISTOR 10 1% .125W F TC0+/-100	24546	C4-1/8-T0-10R0-F
A4R202	0757-0405	4	3	RESISTOR 162 1% .125W F TC0+/-100	24546	C4-1/8-T0-162R-F
A4R203	0698-4825	4	4	RESISTOR 64.9 1% .5W F TC0+/-100	28480	0698-4825
A4R204	0757-0794	4	5	RESISTOR 68.1 1% .5W F TC0+/-100	28480	0757-0794
A4R205	0757-0394	0		RESISTOR 51.1 1% .125W F TC0+/-100	24546	C4-1/8-T0-51R1-F
A4R206	0698-4425	0		RESISTOR 1.54K 1% .125W F TC0+/-100	24546	C4-1/8-T0-1541-F
A4R207	0698-5022	5	2	RESISTOR 40.2 1% .5W F TC0+/-100	28480	0698-5022
A4R208	0757-0280	3		RESISTOR 1K 1% .125W F TC0+/-100	24546	C4-1/8-T0-1001-F
A4R209	0757-0401	0		RESISTOR 100 1% .125W F TC0+/-100	24546	C4-1/8-T0-101-F
A4R211	0757-0346	2		RESISTOR 10 1% .125W F TC0+/-100	24546	C4-1/8-T0-10R0-F
A4R212	0757-0405	4		RESISTOR 162 1% .125W F TC0+/-100	24546	C4-1/8-T0-162R-F
A4R213	0698-4825	4		RESISTOR 64.9 1% .5W F TC0+/-100	28480	0698-4825
A4R214	0757-0794	4		RESISTOR 68.1 1% .5W F TC0+/-100	28480	0757-0794
A4R215	0757-0394	0		RESISTOR 51.1 1% .125W F TC0+/-100	24546	C4-1/8-T0-51R1-F
A4R216	0698-4425	0		RESISTOR 1.54K 1% .125W F TC0+/-100	24546	C4-1/8-T0-1541-F
A4R217	0698-4367	9	2	RESISTOR 20.5 1% .125W F TC0+/-100	03888	PM55-1/8-T0-20R5-F
A4R218	0757-0702	4	2	RESISTOR 36.5 1% .25W F TC0+/-100	24546	C5-1/4-T0-36R5-F
A4R219	0757-0280	3		RESISTOR 1K 1% .125W F TC0+/-100	24546	C4-1/8-T0-1001-F
A4R220	0757-0401	0		RESISTOR 100 1% .125W F TC0+/-100	24546	C4-1/8-T0-101-F
A4R221	0698-3162	0	6	RESISTOR 46.4K 1% .125W F TC0+/-100	24546	C4-1/8-T0-4642-F
A4R222	0757-0438	3		RESISTOR 5.11K 1% .125W F TC0+/-100	24546	C4-1/8-T0-5111-F
A4R223	0698-3162	0		RESISTOR 46.4K 1% .125W F TC0+/-100	24546	C4-1/8-T0-4642-F
A4R225	0757-0421	4	6	RESISTOR 825 1% .125W F TC0+/-100	24546	C4-1/8-T0-825R-F
A4R226	0757-0394	0		RESISTOR 51.1 1% .125W F TC0+/-100	24546	C4-1/8-T0-51R1-F
A4R227	0757-0421	4		RESISTOR 825 1% .125W F TC0+/-100	24546	C4-1/8-T0-825R-F
A4R228	0757-0421	4		RESISTOR 825 1% .125W F TC0+/-100	24546	C4-1/8-T0-825R-F
A4R229	0757-0394	0		RESISTOR 51.1 1% .125W F TC0+/-100	24546	C4-1/8-T0-51R1-F
A4R230	0757-0421	4		RESISTOR 825 1% .125W F TC0+/-100	24546	C4-1/8-T0-825R-F
A4R301	0757-0346	2		RESISTOR 10 1% .125W F TC0+/-100	24546	C4-1/8-T0-10R0-F
A4R302	0698-4413	6	4	RESISTOR 154 1% .125W F TC0+/-100	24546	C4-1/8-T0-154R-F
A4R303	0698-4825	4		RESISTOR 64.9 1% .5W F TC0+/-100	28480	0698-4825
A4R304	0757-0794	4		RESISTOR 68.1 1% .5W F TC0+/-100	28480	0757-0794
A4R305	0757-0794	4		RESISTOR 68.1 1% .5W F TC0+/-100	28480	0757-0794
A4R306	2100-2060	2	3	RESISTOR-TRMR 50 20% C TOP=ADJ 1-TRM	73138	R2PR50
A4R307	0698-5022	5		RESISTOR 40.2 1% .5W F TC0+/-100	28480	0698-5022
A4R308	0757-0280	3		RESISTOR 1K 1% .125W F TC0+/-100	24546	C4-1/8-T0-1001-F
A4R309	0757-0401	0		RESISTOR 100 1% .125W F TC0+/-100	24546	C4-1/8-T0-101-F
A4R310	0757-0394	0		RESISTOR 51.1 1% .125W F TC0+/-100	24546	C4-1/8-T0-51R1-F
A4R311	0757-0346	2		RESISTOR 10 1% .125W F TC0+/-100	24546	C4-1/8-T0-10R0-F
A4R312	0698-4413	6		RESISTOR 154 1% .125W F TC0+/-100	24546	C4-1/8-T0-154R-F
A4R313	0698-4825	4		RESISTOR 64.9 1% .5W F TC0+/-100	28480	0698-4825
A4R314	0757-0794	4		RESISTOR 68.1 1% .5W F TC0+/-100	28480	0757-0794
A4R315	0757-0394	0		RESISTOR 51.1 1% .125W F TC0+/-100	24546	C4-1/8-T0-51R1-F
A4R317	0698-4367	9		RESISTOR 20.5 1% .125W F TC0+/-100	03888	PM55-1/8-T0-20R5-F
A4R318	0757-0702	4		RESISTOR 36.5 1% .25W F TC0+/-100	24546	C5-1/4-T0-36R5-F
A4R319	0757-0280	3		RESISTOR 1K 1% .125W F TC0+/-100	24546	C4-1/8-T0-1001-F
A4R320	0757-0394	0		RESISTOR 51.1 1% .125W F TC0+/-100	24546	C4-1/8-T0-51R1-F
A4R321	0698-3162	0		RESISTOR 46.4K 1% .125W F TC0+/-100	24546	C4-1/8-T0-4642-F
A4R322	0757-0438	3		RESISTOR 5.11K 1% .125W F TC0+/-100	24546	C4-1/8-T0-5111-F
A4R323	0698-3162	0		RESISTOR 46.4K 1% .125W F TC0+/-100	24546	C4-1/8-T0-4642-F
A4R401	0698-4367	1	2	RESISTOR 247.5 .1% .25W F TC0+/-50	19701	MF52C1/4-T2-247R5-B
A4R402	0698-7984	2	3	RESISTOR 61.1 .1% .5W F TC0+/-50	28480	0698-7984
A4R403	0698-7448	3	2	RESISTOR 100 .1% .25W F TC0+/-25	19701	MF52C1/4-T9-100R-B
A4R404	0698-7448	3		RESISTOR 100 .1% .25W F TC0+/-25	19701	MF52C1/4-T9-100R-B
A4R405	0698-8387	1		RESISTOR 247.5 .1% .25W F TC0+/-50	19701	MF52C1/4-T2-247R5-B
A4R406	0698-7984	2		RESISTOR 61.1 .1% .5W F TC0+/-50	28480	0698-7984

Table 6-3. Replaceable Parts (cont'd)

Reference Designation	HP Part Number	C D	Qty	Description	Mfr Code	Mfr Part Number
A4R407	0698-7984	2		RESISTOR 61.1 1% .5W F TC0+50	28480	069A-7984
A4R408	0698-8884	3	2	RESISTOR 150 1% .5W F TC0+25	28480	0698-8884
A4R409	0698-8884	3		RESISTOR 150 1% .5W F TC0+25	28480	069A-8884
A4R410	0698-3488	3	4	RESISTOR 442 1% .125W F TC0+100	24546	C4-1/8-T0-422R-F
A4R501	0757-0438	3		RESISTOR 5.11K 1% .125W F TC0+100	24546	C4-1/8-T0-5111-F
A4R502	0757-0721	7	1	RESISTOR 274 1% .25W F TC0+100	24546	C5-1/4-T0-274R-F
A4R503	0757-0349	5		RESISTOR 22.6K 1% .125W F TC0+100	24546	C4-1/8-T0-2262-F
A4R504	0757-0447	4	1	RESISTOR 16.2K 1% .125W F TC0+100	24546	C4-1/8-T0-1622-F
A4R505	0757-0349	5		RESISTOR 22.6K 1% .125W F TC0+100	24546	C4-1/8-T0-2262-F
A4R506	0698-3443	0	2	RESISTOR 287 1% .125W F TC0+100	24546	C4-1/8-T0-287R-F
A4R507	0757-0394	0		RESISTOR 51.1 1% .125W F TC0+100	24546	C4-1/8-T0-5111-F
A4R508	0757-0394	0		RESISTOR 51.1 1% .125W F TC0+100	24546	C4-1/8-T0-5111-F
A4R510	0757-0349	5		RESISTOR 22.6K 1% .125W F TC0+100	24546	C4-1/8-T0-2262-F
A4R511	0757-0438	3		RESISTOR 5.11K 1% .125W F TC0+100	24546	C4-1/8-T0-5111-F
A4R512	0757-0416	7	3	RESISTOR 511 1% .125W F TC0+100	24546	C4-1/8-T0-511R-F
A4R513	0698-3457	6	1	RESISTOR 316K 1% .125W F TC0+100	28480	0698-3457
A4R514	0698-4539	7	1	RESISTOR 402K 1% .125W F TC0+100	28480	0698-4539
A4R515	0698-3162	0		RESISTOR 46.4K 1% .125W F TC0+100	24546	C4-1/8-T0-4642-F
A4R516	0757-0349	5		RESISTOR 22.6K 1% .125W F TC0+100	24546	C4-1/8-T0-2262-F
A4R517	0698-3162	0		RESISTOR 46.4K 1% .125W F TC0+100	24546	C4-1/8-T0-4642-F
A4R520	0757-0349	5		RESISTOR 22.6K 1% .125W F TC0+100	24546	C4-1/8-T0-2262-F
A4R521	0757-0438	3		RESISTOR 5.11K 1% .125W F TC0+100	24546	C4-1/8-T0-5111-F
A4R522	0757-0349	5		RESISTOR 22.6K 1% .125W F TC0+100	24546	C4-1/8-T0-2262-F
A4R523	0757-0438	3		RESISTOR 5.11K 1% .125W F TC0+100	24546	C4-1/8-T0-5111-F
A4R524	2100-2061	3		RESISTOR-TRMR 200 10% C TOP-ADJ 1-TRN	73138	82PR200
A4R525	2100-2061	3		RESISTOR-TRMR 200 10% C TOP-ADJ 1-TRN	73138	82PR200
A4R526	2100-2061	3		RESISTOR-TRMR 200 10% C TOP-ADJ 1-TRN	73138	82PR200
A4U101	1826-0389	1	1	IC	28480	1826-0389
A4U102	1826-0315	3	3	IC OP AMP GP QUAD 14-DIP-P	27014	LM348N
A4U201	1826-0043	4	13	IC OP AMP GP TO-99	01928	CA307T
A4U202	1826-0043	4		IC OP AMP GP TO-99	01928	CA307T
A4U501	1A20-1961	5	2	IC GATE CMOS NAND TPL 3-INP	04713	MC14023BCP
A4U502	1A20-1961	5		IC GATE CMOS NAND TPL 3-INP	04713	MC14023BCP
A4U503	1A20-1485	8	1	IC MV CMOS MONOSTBL DUAL	27014	MM74C221N
A4VR101	1902-0935	5	6	DIODE-ZNR 9.1V 5% PD5W IR=100UA	28480	1902-0935
A4VR102	1902-0935	5		DIODE-ZNR 9.1V 5% PD5W IR=100UA	28480	1902-0935
A4VR103	1902-3094	3	5	DIODE-ZNR 5.11V 2% DO-7 PD=.4W TC=-.009%	28480	1902-3094
A4VR104	1902-0534	0	2	DIODE-ZNR 3.74V 2% DO-15 PD=1W TC=-.053%	28480	1902-0534
A4VR105	1902-0534	0		DIODE-ZNR 3.74V 2% DO-15 PD=1W TC=-.053%	28480	1902-0534
A4VR107	1902-3182	0	2	DIODE-ZNR 12.1V 5% DO-7 PD=.4W TC=+.064%	28480	1902-3182
A4VR201	1902-3094	3		DIODE-ZNR 5.11V 2% DO-7 PD=.4W TC=-.009%	28480	1902-3094
A4VR202	1902-3188	6		DIODE-ZNR 12.7V 2% DO-7 PD=.4W TC=+.061%	28480	1902-3188
A4VR203	1902-1285	0	2	DIODE-ZNR 12V 5% PD5W IR=50UA	28480	1902-1285
A4VR204	1902-3094	3		DIODE-ZNR 5.11V 2% DO-7 PD=.4W TC=-.009%	28480	1902-3094
A4VR205	1902-3188	6		DIODE-ZNR 12.7V 2% DO-7 PD=.4W TC=+.061%	28480	1902-3188
A4VR206	1902-1285	0		DIODE-ZNR 12V 5% PD5W IR=50UA	28480	1902-1285
A4VR207	1902-0935	5		DIODE-ZNR 9.1V 5% PD5W IR=100UA	28480	1902-0935
A4VR208	1902-0935	5		DIODE-ZNR 9.1V 5% PD5W IR=100UA	28480	1902-0935
A4VR301	1902-0935	5		DIODE-ZNR 9.1V 5% PD5W IR=100UA	28480	1902-0935
A4VR302	1902-0935	5		DIODE-ZNR 9.1V 5% PD5W IR=100UA	28480	1902-0935
AS	08165-66505	8	1	BOARD ASSEMBLY, TIMING	28480	08165-66505
ASC1	0160-3712	7	1	CAPACITOR-FXD 3300PF +-10% 250VDC	28480	0160-3712
ASC2	0160-0375	4	4	CAPACITOR-FXD 68UF+-10% 20VDC TA	56289	1500686X902082
ASC3	0160-0174	9		CAPACITOR-FXD .47UF +80-20% 25VDC CER	28480	0160-0174
ASC4	0160-0573	2		CAPACITOR-FXD 4700PF +-20% 100VDC CER	28480	0160-0573
ASC5	0160-0576	5		CAPACITOR-FXD .1UF +-20% 50VDC CER	28480	0160-0576
ASC6	0160-0196	3	4	CAPACITOR-FXD 150PF +-5% 300VDC MICA	72136	DM15F151J0300HV1CR
ASC7	0160-3879	7		CAPACITOR-FXD .01UF +-20% 100VDC CER	28480	0160-3879
ASC8	0160-0196	3		CAPACITOR-FXD 150PF +-5% 300VDC MICA	72136	DM15F151J0300HV1CR
ASC9	0160-3878	6		CAPACITOR-FXD 1000PF +-20% 100VDC CER	28480	0160-3878
ASC11	0160-3879	7		CAPACITOR-FXD .01UF +-20% 100VDC CER	28480	0160-3879
ASC12	0160-3694	4	2	CAPACITOR-FXD 330PF +-10% 100VDC CER	28480	0160-3694
ASC14	0160-0174	9		CAPACITOR-FXD .47UF +80-20% 25VDC CER	28480	0160-0174
ASC15	0160-2435	1	1	CAPACITOR-FXD 220UF+50-10% 40VDC AL	28480	0160-2435
ASC16	0160-0149	0	1	CAPACITOR-FXD 65UF+100-10% 60VDC AL	28480	0160-0149
ASC17	0160-3879	7		CAPACITOR-FXD .01UF +-20% 100VDC CER	28480	0160-3879
ASC18	0160-0196	3		CAPACITOR-FXD 150PF +-5% 300VDC MICA	72136	DM15F151J0300HV1CR
ASC19	0160-3879	7		CAPACITOR-FXD .01UF +-20% 100VDC CER	28480	0160-3879
ASC21	0160-0683	5	1	CAPACITOR-FXD .02UF +-2% 50VDC POLYSTY	28480	0160-0683
ASC22	0160-4270	4	1	CAPACITOR-FXD .2UF +-1% 50VDC MET-POLYLC	28480	0160-4270
ASC23	0160-0134	1		CAPACITOR-FXD 220PF +-5% 300VDC MICA	28480	0160-0134

Table 6-3. Replaceable Parts (cont'd)

Reference Designation	HP Part Number	C D	Qty	Description	Mfr Code	Mfr Part Number
A5C24	0160-4040	6	>	CAPACITOR-FXD 1000PF +-5% 100VDC CER	28480	0160-4040
A5C25	0160-4040	6		CAPACITOR-FXD 1000PF +-5% 100VDC CER	28480	0160-4040
A5C27	0160-3879	7		CAPACITOR-FXD .01UF +-20% 100VDC CER	28480	0160-3879
A5C28	0160-3878	6		CAPACITOR-FXD 1000PF +-20% 100VDC CER	28480	0160-3878
A5C29	0160-3879	7		CAPACITOR-FXD .01UF +-20% 100VDC CER	28480	0160-3879
A5C31	0160-3878	6		CAPACITOR-FXD 1000PF +-20% 100VDC CER	28480	0160-3878
A5C32	0160-3873	1		CAPACITOR-FXD 4.7PF +- .5PF 200VDC CER	28480	0160-3873
A5C33	0180-0229	7	>	CAPACITOR-FXD 33UF+-10% 10VDC TA	56289	1500336X901082
A5C34	0160-3879	7		CAPACITOR-FXD .01UF +-20% 100VDC CER	28480	0160-3879
A5C35	0160-3879	7		CAPACITOR-FXD .01UF +-20% 100VDC CER	28480	0160-3879
A5C36	0160-3878	6		CAPACITOR-FXD 1000PF +-20% 100VDC CER	28480	0160-3878
A5C37	0160-0174	9		CAPACITOR-FXD .47UF +80-20% 25VDC CER	28480	0160-0174
A5C38	0160-0570	9		CAPACITOR-FXD 220PF +-20% 100VDC CER	20932	5024EM100R0221M
A5C39	0160-0576	5		CAPACITOR-FXD .1UF +-20% 50VDC CER	28480	0160-0576
A5C40	0160-0174	9		CAPACITOR-FXD .47UF +80-20% 25VDC CER	28480	0160-0174
A5C41	0160-0576	5		CAPACITOR-FXD .1UF +-20% 50VDC CER	28480	0160-0576
A5C101	0160-3877	5	2	CAPACITOR-FXD 100PF +-20% 200VDC CER	28480	0160-3877
A5C102	0160-0576	5		CAPACITOR-FXD .1UF +-20% 50VDC CER	28480	0160-0576
A5C103	0160-3877	5		CAPACITOR-FXD 100PF +-20% 200VDC CER	28480	0160-3877
A5C104	0160-3879	7		CAPACITOR-FXD .01UF +-20% 100VDC CER	28480	0160-3879
A5C105	0160-3879	7		CAPACITOR-FXD .01UF +-20% 100VDC CER	28480	0160-3879
A5C106	0180-0197	8		CAPACITOR-FXD 2.2UF+-10% 20VDC TA	56289	1500225X9020A2
A5C107	0160-0576	5		CAPACITOR-FXD .1UF +-20% 50VDC CER	28480	0160-0576
A5C201	0160-3879	7		CAPACITOR-FXD .01UF +-20% 100VDC CER	28480	0160-3879
A5C202	0160-0576	5		CAPACITOR-FXD .1UF +-20% 50VDC CER	28480	0160-0576
A5C203	0160-3879	7		CAPACITOR-FXD .01UF +-20% 100VDC CER	28480	0160-3879
A5C204	0160-0174	9		CAPACITOR-FXD .47UF +80-20% 25VDC CER	28480	0160-0174
A5C205	0160-3879	7		CAPACITOR-FXD .01UF +-20% 100VDC CER	28480	0160-3879
A5C206	0180-1974	1	1	CAPACITOR-FXD 10UF+-10% 35VDC TA	56289	1500106X9035R2
A5C207	0160-3879	7		CAPACITOR-FXD .01UF +-20% 100VDC CER	28480	0160-3879
A5C208	0160-3878	6		CAPACITOR-FXD 1000PF +-20% 100VDC CER	28480	0160-3878
A5C210	0160-0576	5		CAPACITOR-FXD .1UF +-20% 50VDC CER	28480	0160-0576
A5C211	0160-0128	3		CAPACITOR-FXD 2.2UF +-20% 50VDC CER	28480	0160-0128
A5C212	0160-0576	5		CAPACITOR-FXD .1UF +-20% 50VDC CER	28480	0160-0576
A5C301	0160-3878	6		CAPACITOR-FXD 1000PF +-20% 100VDC CER	28480	0160-3878
A5C302	0160-0576	5		CAPACITOR-FXD .1UF +-20% 50VDC CER	28480	0160-0576
A5C303	0160-0576	5		CAPACITOR-FXD .1UF +-20% 50VDC CER	28480	0160-0576
A5C304	0160-3879	7		CAPACITOR-FXD .01UF +-20% 100VDC CER	28480	0160-3879
A5C305	0160-3694	4		CAPACITOR-FXD 330PF +-10% 100VDC CER	28480	0160-3694
A5C306	0160-0576	5		CAPACITOR-FXD .1UF +-20% 50VDC CER	28480	0160-0576
A5C307	0160-3879	7		CAPACITOR-FXD .01UF +-20% 100VDC CER	28480	0160-3879
A5C308	0160-3879	7		CAPACITOR-FXD .01UF +-20% 100VDC CER	28480	0160-3879
A5C309	0121-0467	1	1	CAPACITOR-V TRMR-CER 2.5-9PF 100V PC-MTG	28480	0121-0467
A5C310	0160-3878	6		CAPACITOR-FXD 1000PF +-20% 100VDC CER	28480	0160-3878
A5C311	0160-3875	3	2	CAPACITOR-FXD 22PF +-5% 200VDC CER 0+-30	28480	0160-3875
A5C312	0160-3873	1		CAPACITOR-FXD 4.7PF +- .5PF 200VDC CER	28480	0160-3873
A5C401	0160-3879	7		CAPACITOR-FXD .01UF +-20% 100VDC CER	28480	0160-3879
A5C402	0160-3879	7		CAPACITOR-FXD .01UF +-20% 100VDC CER	28480	0160-3879
A5C403	0160-3879	7		CAPACITOR-FXD .01UF +-20% 100VDC CER	28480	0160-3879
A5C404	0160-3879	7		CAPACITOR-FXD .01UF +-20% 100VDC CER	28480	0160-3879
A5C405	0160-0174	9		CAPACITOR-FXD .47UF +80-20% 25VDC CER	28480	0160-0174
A5C501	0160-3878	6		CAPACITOR-FXD 1000PF +-20% 100VDC CER	28480	0160-3878
A5C502	0160-0576	5		CAPACITOR-FXD .1UF +-20% 50VDC CER	28480	0160-0576
A5C503	0180-2207	5	1	CAPACITOR-FXD 100UF+-10% 10VDC TA	56289	1500107X9010R2
A5C504	0160-3879	7		CAPACITOR-FXD .01UF +-20% 100VDC CER	28480	0160-3879
A5C505	0160-3879	7		CAPACITOR-FXD .01UF +-20% 100VDC CER	28480	0160-3879
A5C506	0180-2208	6	1	CAPACITOR-FXD 220UF+-10% 10VDC TA	56289	1500227X901082
A5CR1	1901-0363	1	1	DIODE-FW BRDG 100V 1A	28480	1901-0363
A5CR2	1901-0050	3		DIODE-SWITCHING 80V 200MA 2NS DO-35	28480	1901-0050
A5CR101	1901-1068	5	9	DIODE-SCHOTTKY	28480	1901-1068
A5CR102	1901-1068	5		DIODE-SCHOTTKY	28480	1901-1068
A5CR103	1901-0533	7	2	DIODE-SCHOTTKY	28480	1901-0533
A5CR104	1901-0533	7		DIODE-SCHOTTKY	28480	1901-0533
A5CR201	1901-1068	5		DIODE-SCHOTTKY	28480	1901-1068
A5CR202	1901-1068	5		DIODE-SCHOTTKY	28480	1901-1068
A5CR203	1901-1068	5		DIODE-SCHOTTKY	28480	1901-1068
A5CR204	1901-1068	5		DIODE-SCHOTTKY	28480	1901-1068
A5CR205	1901-1068	5		DIODE-SCHOTTKY	28480	1901-1068
A5CR301	1901-1068	5		DIODE-SCHOTTKY	28480	1901-1068
A5CR401	1901-1068	5		DIODE-SCHOTTKY	28480	1901-1068
A5CR501	1901-0040	1		DIODE-SWITCHING 30V 50MA 2NS DO-35	28480	1901-0040
A5CR502	1901-0040	1		DIODE-SWITCHING 30V 50MA 2NS DO-35	28480	1901-0040
A5CR503	1901-0040	1		DIODE-SWITCHING 30V 50MA 2NS DO-35	28480	1901-0040
A5CR504	1901-0040	1		DIODE-SWITCHING 30V 50MA 2NS DO-35	28480	1901-0040
A5CR505	1901-0040	1		DIODE-SWITCHING 30V 50MA 2NS DO-35	28480	1901-0040
A5CR506	1901-0040	1		DIODE-SWITCHING 30V 50MA 2NS DO-35	28480	1901-0040
A5CR507	1901-0040	1		DIODE-SWITCHING 30V 50MA 2NS DO-35	28480	1901-0040

Table 6-3. Replaceable Parts (cont'd)

Reference Designation	HP Part Number	C D	Qty	Description	Mfr Code	Mfr Part Number
45CR50A	1901-0040	1	2	DIODE=SWITCHING 30V 50MA 2V8 DD=35	28480	1901-0040
45CR50B	1901-0047	8		DIODE=SWITCHING 20V 75MA 1V8S	28480	1901-0047
45CR510	1901-0047	8		DIODE=SWITCHING 20V 75MA 1V8S	28480	1901-0047
45CR512	1901-0040	1		DIODE=SWITCHING 30V 50MA 2V8 DD=35	28460	1901-0040
45CR513	1901-0040	1		DIODE=SWITCHING 30V 50MA 2V8 DD=35	28480	1901-0040
45CR514	1901-0040	1	DIODE=SWITCHING 30V 50MA 2V8 DD=35	28480	1901-0040	
45CR601	1901-0040	1	DIODE=SWITCHING 30V 50MA 2V8 DD=35	28480	1901-0040	
45CR701	1901-0731	7	DIODE=PNP RECT 400V 1A	28480	1901-0731	
45J1	1251-2026	8	4	CONNECTOR=PC EDGE 18=CONT/ROW 2=ROWS	28480	1251-2026
45J2	1251-2026	8		CONNECTOR=PC EDGE 18=CONT/ROW 2=ROWS	28480	1251-2026
45J3	1251-2026	8		CONNECTOR=PC EDGE 18=CONT/ROW 2=ROWS	28480	1251-2026
45J4	1251-2582	1		CONNECTOR=PC EDGE 24=CONT/ROW 2=ROWS	28480	1251-2582
45J5	1251-2026	8		CONNECTOR=PC EDGE 18=CONT/ROW 2=ROWS	28480	1251-2026
45J6	1251-2582	1	CONNECTOR=PC EDGE 24=CONT/ROW 2=ROWS	28480	1251-2582	
45J7	1251-4504	1	2	CONNECTOR 10=PIN M POST TYPE	28480	1251-4504
45J8	1251-4504	1		CONNECTOR 10=PIN M POST TYPE	28480	1251-4504
45J11	1251-3119	2		CONNECTOR 20=PIN M RECTANGULAR	28480	1251-3119
45K1	0490-1079	4		RELAY-REED 1A 500MA 100VDC 5VDC-COIL	28480	0490-1079
45K2	0490-1079	4	RELAY-REED 1A 500MA 100VDC 5VDC-COIL	28480	0490-1079	
45K3	0490-1079	4	RELAY-REED 1A 500MA 100VDC 5VDC-COIL	28480	0490-1079	
45K4	0490-1079	4	RELAY-REED 1A 500MA 100VDC 5VDC-COIL	28480	0490-1079	
45K5	0490-1079	4	RELAY-REED 1A 500MA 100VDC 5VDC-COIL	28480	0490-1079	
45K301	0490-0617	4	4	RELAY-REED 1C 250MA 28VDC 5VDC-COIL	28480	0490-0617
45K302	0490-1079	4		RELAY-REED 1A 500MA 100VDC 5VDC-COIL	28480	0490-1079
45K401	0490-0617	4		RELAY-REED 1C 250MA 28VDC 5VDC-COIL	28480	0490-0617
45L1	9100-1647	6	2	COIL-MLD 470UH 5% Q#65 .19DX.44LG=NOM	28480	9100-1647
45L2	5081-1973	5		INDUCTANCE, 3-BEAD	28480	5081-1973
45L3	5081-1973	5		INDUCTANCE, 3-BEAD	28480	5081-1973
45L5	9170-0029	3		CORE=SHIELDING BEAD	28480	9170-0029
45L6	9170-0029	3		CORE=SHIELDING BEAD	28480	9170-0029
45L7	9170-0029	3	3	CORE=SHIELDING BEAD	28480	9170-0029
45L8	9170-0029	3		CORE=SHIELDING BEAD	28480	9170-0029
45L9	9170-0029	3		CORE=SHIELDING BEAD	28480	9170-0029
45L10	9100-2251	0		COIL-MLD 220NH 10% Q#32 .095DX.25LG=NOM	28480	9100-2251
45L11	9100-2252	1		COIL-MLD 270NH 10% Q#30 .095DX.25LG=NOM	28480	9100-2252
45L12	9170-0029	3	3	CORE=SHIELDING BEAD	28480	9170-0029
45L201	9170-0029	3		CORE=SHIELDING BEAD	28480	9170-0029
45L301	9170-0029	3		CORE=SHIELDING BEAD	28480	9170-0029
45L302	9100-2247	4		COIL-MLD 160NH 10% Q#34 .095DX.25LG=NOM	28480	9100-2247
45L303	9170-0029	3		CORE=SHIELDING BEAD	28480	9170-0029
45L401	9170-0029	3	3	CORE=SHIELDING BEAD	28480	9170-0029
45L402	9100-1647	6		COIL-MLD 470UH 5% Q#65 .19DX.44LG=NOM	28480	9100-1647
45L403	5081-1973	5		INDUCTANCE, 3-BEAD	28480	5081-1973
45L405	9100-0346	0		COIL-MLD 50NH 20% Q#40 .095DX.25LG=NOM	28480	9100-0346
45L406	9170-0029	3		CORE=SHIELDING BEAD	28480	9170-0029
45L501	9140-0210	1	1	COIL-MLD 100UH 5% Q#50 .155DX.375LG=NOM	28480	9140-0210
45MP1	1205-0011	0	2	HEAT SINK TO=5/TO=39-CS	28480	1205-0011
45MP2	01801-22301	7		HEAT SINK	28480	01801-22301
45MP3	1205-0204	3		HEAT SINK TO=18-CS	28480	1205-0204
45MP4	1205-0037	0		HEAT SINK TO=18-CS	28480	1205-0037
45MP5	08165-03202	0		1	COUPLER, THERMAL	28480
45MP6	1205-0037	0	0	HEAT SINK TO=18-CS	28480	1205-0037
45MP7	1205-0037	0		HEAT SINK TO=18-CS	28480	1205-0037
45MP201	1205-0037	0		HEAT SINK TO=18-CS	28480	1205-0037
45MP202	1205-0037	0		HEAT SINK TO=18-CS	28480	1205-0037
45MP301	1205-0011	0		HEAT SINK TO=5/TO=39-CS	28480	1205-0011
45MP302	1205-0037	0	0	HEAT SINK TO=18-CS	28480	1205-0037
45MP401	1205-0037	0		HEAT SINK TO=18-CS	28480	1205-0037
45Q1	1854-0477	7	5	TRANSISTOR NPN 2N2222A SI TO=18 PD=500MW	04713	2N2222A
45Q2	1854-0472	2		TRANSISTOR NPN SI DARL PD=500MW	04713	MP8-A14
45Q3	1853-0086	2		TRANSISTOR PNP SI PD=310MW FT=40MHZ	27014	2N5087
45Q4	1853-0281	9		TRANSISTOR PNP 2N2907A SI TO=18 PD=400MW	04713	2N2907A
45Q5	1853-0086	2		TRANSISTOR PNP SI PD=310MW FT=40MHZ	27014	2N5087
45Q6	1853-0086	2	2	TRANSISTOR PNP SI PD=310MW FT=40MHZ	27014	2N5087
45Q7	1854-0075	9		TRANSISTOR-DUAL PNP PD=400MW	28480	1853-0075
45Q8	1853-0314	9		TRANSISTOR PNP 2N2905A SI TO=39 PD=600MW	04713	2N2905A
45Q9	1854-0472	2		TRANSISTOR NPN SI DARL PD=500MW	04713	MP8-A14
45Q10	1855-0215	3		3	TRANSISTOR MOSFET N-CHAN E-MODE TO=72 SI	28480
45Q12	5081-1977	9	7	FET, SELECTED	28480	5081-1977
45Q13	1854-0485	7		TRANSISTOR NPN SI TO=104 PD=175MW	28480	1854-0485
45Q14	1854-0354	9		TRANSISTOR NPN SI TO=52 PD=360MW	28480	1854-0354
45Q16	1854-0485	7		TRANSISTOR NPN SI TO=104 PD=175MW	28480	1854-0485
45Q17	1854-0485	7		TRANSISTOR NPN SI TO=104 PD=175MW	28480	1854-0485

Table 6-3. Replaceable Parts (cont'd)

Reference Designation	HP Part Number	C D	Qty	Description	Mfr Code	Mfr Part Number
A5Q18	1854-0305	0	2	TRANSISTOR NPN SI TO-18 PD=400MW	28480	1854-0305
A5Q19	1854-0305	0		TRANSISTOR NPN SI TO-18 PD=400MW	28480	1854-0305
A5Q20	1855-0215	3		TRANSISTOR MOSFET N-CHAN E-MODE TO-72 SI	28480	1855-0215
A5Q21	1854-0472	2		TRANSISTOR NPN SI DARL PD=500MW	04713	MP8-A14
A5Q22	1854-0485	7		TRANSISTOR NPN SI TO-104 PD=175MW	28480	1854-0485
A5Q23	1854-0354	9		TRANSISTOR NPN SI TO-52 PD=360MW	28480	1854-0354
A5Q24	1854-0215	1		TRANSISTOR NPN SI PD=350W FT=300MHZ	04713	2N3904
A5Q25	1853-0357	0	A	TRANSISTOR PNP SI TO-18 PD=360MW	28480	1853-0357
A5Q101	1853-0357	0		TRANSISTOR PNP SI TO-18 PD=360MW	28480	1853-0357
A5Q102	1853-0357	0		TRANSISTOR PNP SI TO-18 PD=360MW	28480	1853-0357
A5Q103	1853-0357	0		TRANSISTOR PNP SI TO-18 PD=360MW	28480	1853-0357
A5Q104	1853-0314	9		TRANSISTOR PNP 2N2905A SI TO-39 PD=600MW	04713	2N2905A
A5Q105	1854-0472	2		TRANSISTOR NPN SI DARL PD=500MW	04713	MP8-A14
A5Q106	1854-0354	9		TRANSISTOR NPN SI TO-52 PD=360MW	28480	1854-0354
A5Q107	1854-0637	1		TRANSISTOR NPN 2N2219A SI TO-5 PD=800MW	01295	2N2219A
A5Q108	1855-0215	2		TRANSISTOR MOSFET N-CHAN E-MODE TO-72 SI	28480	1855-0215
A5Q109	1853-0036	3		TRANSISTOR PNP SI PD=310W FT=250MHZ	28480	1853-0036
A5Q201	1854-0354	9		TRANSISTOR NPN SI TO-52 PD=360MW	28480	1854-0354
A5Q202	1854-0215	1		TRANSISTOR NPN SI PD=350W FT=300MHZ	04713	2N3904
A5Q203	1853-0357	0		TRANSISTOR PNP SI TO-18 PD=360MW	28480	1853-0357
A5Q204	1853-0357	0		TRANSISTOR PNP SI TO-18 PD=360MW	28480	1853-0357
A5Q205	1854-0215	1		TRANSISTOR NPN SI PD=350W FT=300MHZ	04713	2N3904
A5Q206	1853-0357	0		TRANSISTOR PNP SI TO-18 PD=360MW	28480	1853-0357
A5Q207	1853-0281	9		TRANSISTOR PNP 2N2907A SI TO-18 PD=400MW	04713	2N2907A
A5Q208	1853-0357	0		TRANSISTOR PNP SI TO-18 PD=360MW	28480	1853-0357
A5Q209	1853-0036	2		TRANSISTOR PNP SI PD=310W FT=250MHZ	28480	1853-0036
A5Q210	1853-0036	2		TRANSISTOR PNP SI PD=310W FT=250MHZ	28480	1853-0036
A5Q211	1854-0215	1		TRANSISTOR NPN SI PD=350W FT=300MHZ	04713	2N3904
A5Q212	1853-0314	9		TRANSISTOR PNP 2N2905A SI TO-39 PD=600MW	04713	2N2905A
A5Q301	1854-0354	9		TRANSISTOR NPN SI TO-52 PD=360MW	28480	1854-0354
A5Q302	1853-0281	9		TRANSISTOR PNP 2N2907A SI TO-18 PD=400MW	04713	2N2907A
A5Q303	1853-0075	9		TRANSISTOR-DUAL PNP PD=400MW	28480	1853-0075
A5Q304	1853-0036	2		TRANSISTOR PNP SI PD=310W FT=250MHZ	28480	1853-0036
A5Q401	1854-0354	9		TRANSISTOR NPN SI TO-52 PD=360MW	28480	1854-0354
A5Q402	1854-0477	7		TRANSISTOR NPN 2N2222A SI TO-18 PD=500MW	04713	2N2222A
A5Q403	1853-0036	2		TRANSISTOR PNP SI PD=310W FT=250MHZ	28480	1853-0036
A5Q404	1854-0354	9		TRANSISTOR NPN SI TO-52 PD=360MW	28480	1854-0354
A5Q501	1854-0215	1		TRANSISTOR NPN SI PD=350W FT=300MHZ	04713	2N3904
A5Q502	1854-0215	1		TRANSISTOR NPN SI PD=350W FT=300MHZ	04713	2N3904
A5Q503	1854-0215	1		TRANSISTOR NPN SI PD=350W FT=300MHZ	04713	2N3904
A5Q504	1854-0215	1		TRANSISTOR NPN SI PD=350W FT=300MHZ	04713	2N3904
A5Q505	1854-0215	1		TRANSISTOR NPN SI PD=350W FT=300MHZ	04713	2N3904
A5Q506	1854-0215	1		TRANSISTOR NPN SI PD=350W FT=300MHZ	04713	2N3904
A5Q507	1854-0215	1		TRANSISTOR NPN SI PD=350W FT=300MHZ	04713	2N3904
A5Q508	1854-0215	1		TRANSISTOR NPN SI PD=350W FT=300MHZ	04713	2N3904
A5Q509	1853-0036	2		TRANSISTOR PNP SI PD=310W FT=250MHZ	28480	1853-0036
A5Q510	1853-0036	2		TRANSISTOR PNP SI PD=310W FT=250MHZ	28480	1853-0036
A5Q511	1854-0215	1		TRANSISTOR NPN SI PD=350W FT=300MHZ	04713	2N3904
A5Q512	1854-0215	1		TRANSISTOR NPN SI PD=350W FT=300MHZ	04713	2N3904
A5Q513	1854-0583	6	6	TRANSISTOR NPN SI TO-92 PD=310MW	04713	MP8-A18
A5Q514	1854-0215	1		TRANSISTOR NPN SI PD=350W FT=300MHZ	04713	2N3904
A5Q515	1854-0215	1		TRANSISTOR NPN SI PD=350W FT=300MHZ	04713	2N3904
A5Q516	1854-0215	1		TRANSISTOR NPN SI PD=350W FT=300MHZ	04713	2N3904
A5Q517	1853-0036	2		TRANSISTOR PNP SI PD=310W FT=250MHZ	28480	1853-0036
A5Q518	1854-0215	1		TRANSISTOR NPN SI PD=350W FT=300MHZ	04713	2N3904
A5Q601	1854-0215	1		TRANSISTOR NPN SI PD=350W FT=300MHZ	04713	2N3904
ASR1	0757-0280	3		RESISTOR 1K 1% .125W F TC=0+-100	24546	C4=1/8-T0=1001-F
ASR2	0757-0449	6	7	RESISTOR 20K 1% .125W F TC=0+-100	24546	C4=1/8-T0=2002-F
ASR3	0698-0428	3	5	RESISTOR 1.69K 1% .125W F TC=0+-100	24546	C4=1/8-T0=1691-F
ASR4	0757-0401	0		RESISTOR 100 1% .125W F TC=0+-100	24546	C4=1/8-T0=101-F
ASR5	0757-0465	6		RESISTOR 100K 1% .125W F TC=0+-100	24546	C4=1/8-T0=1003-F
ASR6	0698-6615	4	1	RESISTOR 3.75K .1% .125W F TC=0+-25	28480	0698-6615
ASR7	0757-0453	2	1	RESISTOR 30.1K 1% .125W F TC=0+-100	24546	C4=1/8-T0=3012-F
ASR8	0698-6624	5	1	RESISTOR 2K .1% .125W F TC=0+-25	28480	0698-6624
ASR9	0757-0407	6		RESISTOR 200 1% .125W F TC=0+-100	24546	C4=1/8-T0=201-F
ASR10	2100-3210	6	1	RESISTOR-TRMR 10K 10% C TOP=ADJ 1-TRN	28480	2100-3210
ASR11	0698-3558	8		RESISTOR 4.02K 1% .125W F TC=0+-100	24546	C4=1/8-T0=4021-F
ASR12	0757-0200	7		RESISTOR 5.62K 1% .125W F TC=0+-100	24546	C4=1/8-T0=5621-F
ASR13	0698-5453	6	2	RESISTOR 900 .1% .125W F TC=0+-50	03888	PME55 T=2-900R-R
ASR14	0698-5453	6		RESISTOR 900 .1% .125W F TC=0+-50	03888	PME55 T=2-900R-R
ASR15	0698-4086	9		RESISTOR 22.6 1% .125W F TC=0+-100	03888	PME55=1/8-T0=22R6-F
ASR16	0698-6616	5	1	RESISTOR 750 .1% .125W F TC=0+-25	28480	0698-6616
ASR17	0698-4424	9	1	RESISTOR 1.4K 1% .125W F TC=0+-100	24546	C4=1/8-T0=1401-F
ASR18	0757-0280	3	5	RESISTOR 1K 1% .125W F TC=0+-100	24546	C4=1/8-T0=1001-F
ASR19	0698-4435	2	5	RESISTOR 2.49K 1% .125W F TC=0+-100	24546	C4=1/8-T0=2491-F
ASR20	0698-3499	6	2	RESISTOR 40.2K 1% .125W F TC=0+-100	24546	C4=1/8-T0=4022-F

Table 6-3. Replaceable Parts (cont'd)

Reference Designation	HP Part Number	C D	Qty	Description	Mfr Code	Mfr Part Number
ASR21	0698-3178	8		RESISTOR 487 1% .125W F TC=0+-100	24546	C4-1/8-T0=487R-F
ASR22	0698-5824	1	1	RESISTOR 562K 1% .125W F TC=0+-100	24546	0698-5824
ASR23	0698-7209	4	1	RESISTOR 75 1% .05W F TC=0+-100	24546	C3-1/8-T00=75R0-G
ASR24	0698-3152	8	3	RESISTOR 3.48K 1% .125W F TC=0+-100	24546	C4-1/8-T0=3481-F
ASR25	0698-7188	8	4	RESISTOR 10 1% .05W F TC=0+-100	24546	C3-1/8-T00=10R-G
ASR26	0698-4444	3		RESISTOR 4.47K 1% .125W F TC=0+-100	24546	C4-1/8-T0=4471-F
ASR27	0757-0449	6		RESISTOR 20K 1% .125W F TC=0+-100	24546	C4-1/8-T0=2002-F
ASR28	0698-3223	4	2	RESISTOR 1.24K 1% .125W F TC=0+-100	24546	C4-1/8-T0=1241-F
ASR29	0757-0401	0		RESISTOR 100 1% .125W F TC=0+-100	24546	C4-1/8-T0=101-F
ASR31	0757-0407	6		RESISTOR 200 1% .125W F TC=0+-100	24546	C4-1/8-T0=201-F
ASR32	0698-3223	4		RESISTOR 1.24K 1% .125W F TC=0+-100	24546	C4-1/8-T0=1241-F
ASR34	0698-5094	1	3	RESISTOR 5.1M 5% .25W FC TC=900/+1100	01121	CR5155
ASR36	0698-3557	7	1	RESISTOR 806 1% .125W F TC=0+-100	24546	C4-1/8-T0=806R-F
ASR38	0698-4456	7	1	RESISTOR 549 1% .125W F TC=0+-100	24546	C4-1/8-T0=549R-F
ASR40	0757-0476	9	1	RESISTOR 301K 1% .125W F TC=0+-100	24546	C4-1/8-T0=3013-F
ASR41	0757-0346	2		RESISTOR 10 1% .125W F TC=0+-100	24546	C4-1/8-T0=10R0-F
ASR42	0757-0283	6		RESISTOR 2K 1% .125W F TC=0+-100	24546	C4-1/8-T0=2001-F
ASR43	0698-4435	2		RESISTOR 2.49K 1% .125W F TC=0+-100	24546	C4-1/8-T0=2491-F
ASR45	0757-0394	0		RESISTOR 51.1 1% .125W F TC=0+-100	24546	C4-1/8-T0=51R1-F
ASR50	0698-3437	2	4	RESISTOR 133 1% .125W F TC=0+-100	24546	C4-1/8-T0=133R-F
ASR51	2100-2080	2		RESISTOR-TRMR 50 20% C TOP-ADJ 1-TRN	73138	A2PR50
ASR52	0757-0346	2		RESISTOR 10 1% .125W F TC=0+-100	24546	C4-1/8-T0=10R0-F
ASR53	0757-0407	6		RESISTOR 200 1% .125W F TC=0+-100	24546	C4-1/8-T0=201-F
ASR54	0698-4456	6	2	RESISTOR 536 1% .125W F TC=0+-100	24546	C4-1/8-T0=536R-F
ASR55	0698-7221	0	1	RESISTOR 237 1% .05W F TC=0+-100	24546	C3-1/8-T0=237R-G
ASR56	0757-0394	0		RESISTOR 51.1 1% .125W F TC=0+-100	24546	C4-1/8-T0=51R1-F
ASR57	0757-0274	5	10	RESISTOR 1.21K 1% .125W F TC=0+-100	24546	C4-1/8-T0=1213-F
ASR58	0757-0388	2	6	RESISTOR 30.1 1% .125W F TC=0+-100	24546	C4-1/8-T0=30R1-F
ASR60	0757-0346	2		RESISTOR 10 1% .125W F TC=0+-100	24546	C4-1/8-T0=10R0-F
ASR61	0698-4422	7	3	RESISTOR 1.27K 1% .125W F TC=0+-100	24546	C4-1/8-T0=1271-F
ASR62	0757-0407	6		RESISTOR 200 1% .125W F TC=0+-100	24546	C4-1/8-T0=201-F
ASR63	0698-4455	6		RESISTOR 536 1% .125W F TC=0+-100	24546	C4-1/8-T0=536R-F
ASR64	0698-3111	9	A	RESISTOR 30 5% .125W CC TC=270/+540	01121	BB3005
ASR65	0698-7205	0		RESISTOR 51.1 1% .05W F TC=0+-100	24546	C3-1/8-T00=51R1-G
ASR66	0698-4424	9		RESISTOR 1.4K 1% .125W F TC=0+-100	24546	C4-1/8-T0=1401-F
ASR67	0757-0438	3		RESISTOR 5.11K 1% .125W F TC=0+-100	24546	C4-1/8-T0=5111-F
ASR68	0757-0290	5	4	RESISTOR 6.19K 1% .125W F TC=0+-100	19701	MF4C1/8-T0=6191-F
ASR69	0757-0407	6		RESISTOR 200 1% .125W F TC=0+-100	24546	C4-1/8-T0=201-F
ASR70	0757-0405	4		RESISTOR 162 1% .125W F TC=0+-100	24546	C4-1/8-T0=162R-F
ASR71	2100-3288	8	1	RESISTOR-TRMR 50 20% C TOP-ADJ 17-TRN	28480	2100-3288
ASR73	0698-4424	9		RESISTOR 1.4K 1% .125W F TC=0+-100	24546	C4-1/8-T0=1401-F
ASR74	0757-0388	2		RESISTOR 30.1 1% .125W F TC=0+-100	24546	C4-1/8-T0=30R1-F
ASR76	0698-3439	4		RESISTOR 178 1% .125W F TC=0+-100	24546	C4-1/8-T0=178R-F
ASR77	0757-0384	8		RESISTOR 20 1% .125W F TC=0+-100	19701	MF4C1/8-T0=20R0-F
ASR78	0698-3442	9		RESISTOR 237 1% .125W F TC=0+-100	24546	C4-1/8-T0=237R-F
ASR80	0757-1094	9		RESISTOR 1.47K 1% .125W F TC=0+-100	24546	C4-1/8-T0=1471-F
ASR81	0757-0433	8	5	RESISTOR 3.32K 1% .125W F TC=0+-100	24546	C4-1/8-T0=3321-F
ASR82	0698-4435	2		RESISTOR 2.49K 1% .125W F TC=0+-100	24546	C4-1/8-T0=2491-F
ASR83	0757-0816	1	1	RESISTOR 681 1% .5W F TC=0+-100	28480	0757-0816
ASR84	0698-4379	3	1	RESISTOR 44.2 1% .125W F TC=0+-100	24546	C4-1/8-T0=44R2-F
ASR85	0757-0398	4	1	RESISTOR 75 1% .125W F TC=0+-100	24546	C4-1/8-T0=75R0-F
ASR86	0757-0407	6		RESISTOR 200 1% .125W F TC=0+-100	24546	C4-1/8-T0=201-F
ASR87	0757-0428	1	2	RESISTOR 1.62K 1% .125W F TC=0+-100	24546	C4-1/8-T0=1621-F
ASR88	0757-0388	2		RESISTOR 30.1 1% .125W F TC=0+-100	24546	C4-1/8-T0=30R1-F
ASR101	0757-0401	0		RESISTOR 100 1% .125W F TC=0+-100	24546	C4-1/8-T0=101-F
ASR102	0757-0402	1	4	RESISTOR 110 1% .125W F TC=0+-100	24546	C4-1/8-T0=111-F
ASR103	0698-4453	4	10	RESISTOR 402 1% .125W F TC=0+-100	24546	C4-1/8-T0=402R-F
ASR105	0757-0416	7		RESISTOR 511 1% .125W F TC=0+-100	24546	C4-1/8-T0=511R-F
ASR106	0757-0416	7		RESISTOR 511 1% .125W F TC=0+-100	24546	C4-1/8-T0=511R-F
ASR107	0757-0725	1	1	RESISTOR 475 1% .25W F TC=0+-100	24546	C5-1/4-T0=475R-F
ASR108	0757-0410	1	4	RESISTOR 301 1% .125W F TC=0+-100	24546	C4-1/8-T0=301R-F
ASR109	0757-0410	1		RESISTOR 301 1% .125W F TC=0+-100	24546	C4-1/8-T0=301R-F
ASR110	0757-0401	0		RESISTOR 100 1% .125W F TC=0+-100	24546	C4-1/8-T0=101-F
ASR111	0698-7188	8		RESISTOR 10 1% .05W F TC=0+-100	24546	C3-1/8-T00=10R-G
ASR112	0757-0438	3		RESISTOR 5.11K 1% .125W F TC=0+-100	24546	C4-1/8-T0=5111-F
ASR115	2100-0567	0	1	RESISTOR-TRMR 2K 10% C TOP-ADJ 1-TRN	28480	2100-0567
ASR116	0698-3154	0	4	RESISTOR 4.22K 1% .125W F TC=0+-100	24546	C4-1/8-T0=4221-F
ASR117	0698-3450	9	3	RESISTOR 42.2K 1% .125W F TC=0+-100	24546	C4-1/8-T0=4222-F
ASR118	0757-0273	4		RESISTOR 3.01K 1% .125W F TC=0+-100	24546	C4-1/8-T0=3011-F
ASR119	0698-0085	0	3	RESISTOR 2.61K 1% .125W F TC=0+-100	24546	C4-1/8-T0=2611-F
ASR120	0757-0407	6		RESISTOR 200 1% .125W F TC=0+-100	24546	C4-1/8-T0=201-F
ASR121	0757-0805	8	2	RESISTOR 221 1% .5W F TC=0+-100	28480	0757-0805
ASR122	0698-3495	2	2	RESISTOR 866 1% .125W F TC=0+-100	24546	C4-1/8-T0=866R-F
ASR123	0757-0410	1		RESISTOR 301 1% .125W F TC=0+-100	24546	C4-1/8-T0=301R-F
ASR124	0757-0442	9		RESISTOR 10K 1% .125W F TC=0+-100	24546	C4-1/8-T0=1002-F

Table 6-3. Replaceable Parts (cont'd)

Reference Designation	HP Part Number	C D	Qty	Description	Mfr Code	Mfr Part Number
A5R125	0757-0449	6		RESISTOR 20K 1% .125W F TC0+100	24546	C4-1/8-T0=2002-F
A5R126	0757-0438	3		RESISTOR 5.11K 1% .125W F TC0+100	24546	C4-1/8-T0=5111-F
A5R201	0757-0384	8		RESISTOR 20 1% .125W F TC0+100	19701	MF4C1/8-T0=20A0-F
A5R202	0698-3178	8		RESISTOR 487 1% .125W F TC0+100	24546	C4-1/8-T0=487P-F
A5R203	0757-0280	3		RESISTOR 1K 1% .125W F TC0+100	24546	C4-1/8-T0=1001-F
A5R204	0757-0401	0		RESISTOR 100 1% .125W F TC0+100	24546	C4-1/8-T0=101-F
A5R205	0757-0394	0		RESISTOR 51.1 1% .125W F TC0+100	24546	C4-1/8-T0=5111-F
A5R207	0757-0410	1		RESISTOR 301 1% .125W F TC0+100	24546	C4-1/8-T0=301R-F
A5R208	0757-0401	0		RESISTOR 100 1% .125W F TC0+100	24546	C4-1/8-T0=101-F
A5R209	0698-3178	8		RESISTOR 487 1% .125W F TC0+100	24546	C4-1/8-T0=487R-F
A5R210	0757-0280	3		RESISTOR 1K 1% .125W F TC0+100	24546	C4-1/8-T0=1001-F
A5R211	0757-0419	0	11	RESISTOR 681 1% .125W F TC0+100	24546	C4-1/8-T0=681R-F
A5R212	0757-0419	0		RESISTOR 681 1% .125W F TC0+100	24546	C4-1/8-T0=681R-F
A5R213	0757-0407	6		RESISTOR 200 1% .125W F TC0+100	24546	C4-1/8-T0=201-F
A5R214	0698-4473	8	2	RESISTOR 1.37K 1% .125W F TC0+100	24546	C4-1/8-T0=1371-F
A5R215	0757-0346	2		RESISTOR 10 1% .125W F TC0+100	24546	C4-1/8-T0=10R0-F
A5R216	0757-0805	5		RESISTOR 221 1% .5W F TC0+100	24880	0757-0805
A5R217	0698-3258	8	2	RESISTOR 5.36K 1% .125W F TC0+100	24546	C4-1/8-T0=5361-F
A5R218	0698-4473	8		RESISTOR 1.37K 1% .125W F TC0+100	24546	C4-1/8-T0=1371-F
A5R219	0757-0407	6		RESISTOR 200 1% .125W F TC0+100	24546	C4-1/8-T0=201-F
A5R220	0757-0346	2		RESISTOR 10 1% .125W F TC0+100	24546	C4-1/8-T0=10R0-F
A5R221	0757-0394	0		RESISTOR 51.1 1% .125W F TC0+100	24546	C4-1/8-T0=5111-F
A5R223	0757-0394	0		RESISTOR 51.1 1% .125W F TC0+100	24546	C4-1/8-T0=5111-F
A5R224	0757-0394	0		RESISTOR 51.1 1% .125W F TC0+100	24546	C4-1/8-T0=5111-F
A5R225	0757-0438	3		RESISTOR 5.11K 1% .125W F TC0+100	24546	C4-1/8-T0=5111-F
A5R228	0757-0407	6		RESISTOR 200 1% .125W F TC0+100	24546	C4-1/8-T0=201-F
A5R229	0757-0280	3		RESISTOR 1K 1% .125W F TC0+100	24546	C4-1/8-T0=1001-F
A5R231	0698-3447	4		RESISTOR 422 1% .125W F TC0+100	24546	C4-1/8-T0=422R-F
A5R232	0757-0407	6		RESISTOR 200 1% .125W F TC0+100	24546	C4-1/8-T0=201-F
A5R233	0757-0424	7	3	RESISTOR 1.1K 1% .125W F TC0+100	24546	C4-1/8-T0=1101-F
A5R234	0757-0395	1	1	RESISTOR 56.2 1% .125W F TC0+100	24546	C4-1/8-T0=562R-F
A5R235	2100-2060	2		RESISTOR-TRMR 50 20% C TOP-ADJ 1-TRN	73138	R2PR50
A5R236	0757-0401	0		RESISTOR 100 1% .125W F TC0+100	24546	C4-1/8-T0=101-F
A5R237	0698-3159	5	3	RESISTOR 26.1K 1% .125W F TC0+100	24546	C4-1/8-T0=2612-F
A5R238	0757-0438	3		RESISTOR 5.11K 1% .125W F TC0+100	24546	C4-1/8-T0=5111-F
A5R239	0757-0454	3	7	RESISTOR 33.2K 1% .125W F TC0+100	24546	C4-1/8-T0=3322-F
A5R241	0757-0449	6		RESISTOR 20K 1% .125W F TC0+100	24546	C4-1/8-T0=2002-F
A5R242	0757-0290	5		RESISTOR 6.19K 1% .125W F TC0+100	19701	MF4C1/8-T0=6191-F
A5R244	0698-4424	9		RESISTOR 1.4K 1% .125W F TC0+100	24546	C4-1/8-T0=1401-F
A5R245	0757-0283	6		RESISTOR 2K 1% .125W F TC0+100	24546	C4-1/8-T0=2001-F
A5R246	0757-0407	6		RESISTOR 200 1% .125W F TC0+100	24546	C4-1/8-T0=201-F
A5R247	0757-0801	4	1	RESISTOR 150 1% .5W F TC0+100	24880	0757-0801
A5R248	0698-4408	9	1	RESISTOR 124 1% .125W F TC0+100	24546	C4-1/8-T0=124R-F
A5R301	0698-3374	6	2	RESISTOR 20 5% .125W CC TC=270/+540	01121	BB2005
A5R302	0757-0458	7		RESISTOR 51.1K 1% .125W F TC0+100	24546	C4-1/8-T0=5112-F
A5R303	0698-7212	9	6	RESISTOR 100 1% .05W F TC0+100	24546	C3-1/8-T0=100R-G
A5R304	0698-4413	6		RESISTOR 154 1% .125W F TC0+100	24546	C4-1/8-T0=154R-F
A5R305	0698-4413	6		RESISTOR 154 1% .125W F TC0+100	24546	C4-1/8-T0=154R-F
A5R306	0698-3111	9		RESISTOR 30 5% .125W CC TC=270/+540	01121	BB3005
A5R307	0698-7223	2	10	RESISTOR 287 1% .05W F TC0+100	24546	C3-1/8-T0=287R-G
A5R308	0698-7223	2		RESISTOR 287 1% .05W F TC0+100	24546	C3-1/8-T0=287R-G
A5R309	0698-4429	4	2	RESISTOR 1.87K 1% .125W F TC0+100	24546	C4-1/8-T0=1871-F
A5R310	0698-7212	9		RESISTOR 100 1% .05W F TC0+100	24546	C3-1/8-T0=100R-G
A5R311	0698-4409	0	3	RESISTOR 127 1% .125W F TC0+100	24546	C4-1/8-T0=127R-F
A5R312	0698-4409	0		RESISTOR 127 1% .125W F TC0+100	24546	C4-1/8-T0=127R-F
A5R313	0698-3111	9		RESISTOR 30 5% .125W CC TC=270/+540	01121	BB3005
A5R314	0698-7223	2		RESISTOR 287 1% .05W F TC0+100	24546	C3-1/8-T0=287R-G
A5R315	0698-7223	2		RESISTOR 287 1% .05W F TC0+100	24546	C3-1/8-T0=287R-G
A5R316	0757-0421	4		RESISTOR 825 1% .125W F TC0+100	24546	C4-1/8-T0=825R-F
A5R317	0698-7212	9		RESISTOR 100 1% .05W F TC0+100	24546	C3-1/8-T0=100R-G
A5R318	0698-4406	7	2	RESISTOR 115 1% .125W F TC0+100	24546	C4-1/8-T0=115R-F
A5R319	0698-4406	7		RESISTOR 115 1% .125W F TC0+100	24546	C4-1/8-T0=115R-F
A5R320	0698-3111	9		RESISTOR 30 5% .125W CC TC=270/+540	01121	BB3005
A5R321	0698-7223	2		RESISTOR 287 1% .05W F TC0+100	24546	C3-1/8-T0=287R-G
A5R322	0698-7223	2		RESISTOR 287 1% .05W F TC0+100	24546	C3-1/8-T0=287R-G
A5R323	0757-0418	9		RESISTOR 619 1% .125W F TC0+100	24546	C4-1/8-T0=619R-F
A5R324	0698-7212	9		RESISTOR 100 1% .05W F TC0+100	24546	C3-1/8-T0=100R-G
A5R325	0698-3132	4		RESISTOR 261 1% .125W F TC0+100	24546	C4-1/8-T0=2610-F
A5R326	0698-3132	4		RESISTOR 261 1% .125W F TC0+100	24546	C4-1/8-T0=2610-F
A5R327	0698-3111	9		RESISTOR 30 5% .125W CC TC=270/+540	01121	BB3005
A5R328	0698-7223	2		RESISTOR 287 1% .05W F TC0+100	24546	C3-1/8-T0=287R-G
A5R329	0698-7223	2		RESISTOR 287 1% .05W F TC0+100	24546	C3-1/8-T0=287R-G
A5R330	0698-3518	0	1	RESISTOR 7.32K 1% .125W F TC0+100	24546	C4-1/8-T0=7321-F
A5R331	0698-7212	9		RESISTOR 100 1% .05W F TC0+100	24546	C3-1/8-T0=100R-G
A5R332	0698-4411	4	3	RESISTOR 140 1% .125W F TC0+100	24546	C4-1/8-T0=140R-F

Table 6-3. Replaceable Parts (cont'd)

Reference Designation	HP Part Number	C D	Qty	Description	Mfr Code	Mfr Part Number
A5R333	0698-3411	4		RESISTOR 140 1X .125W F TC0+100	24546	C4=1/8-T0=140H-F
A5R334	0698-3111	0		RESISTOR 30 5X .125W CC TC=-270/+540	01121	RB3005
A5R335	0698-7223	2		RESISTOR 287 1X .05W F TC0+100	24546	C3=1/8-T0=287F-G
A5R336	0698-7223	2		RESISTOR 287 1X .05W F TC0+100	24546	C3=1/8-T0=287R-G
A5R337	0698-4468	1	1	RESISTOR 1.13K 1X .125W F TC0+100	24546	C4=1/8-T0=1131-F
A5R338	0698-4422	7		RESISTOR 1.27K 1X .125W F TC0+100	24546	C4=1/8-T0=1271-F
A5R339	0757-0273	4		RESISTOR 3.01K 1X .125W F TC0+100	24546	C4=1/8-T0=3011-F
A5R341	0757-0438	3		RESISTOR 5.11K 1X .125W F TC0+100	24546	C4=1/8-T0=5111-F
A5R342	0698-7238	9	1	RESISTOR 1.21K 1X .05W F TC0+100	24546	C3=1/8-T0=1211-G
A5R343	0698-7212	9		RESISTOR 100 1X .05W F TC0+100	24546	C3=1/8-T0=100R-G
A5R344	0757-0402	1		RESISTOR 110 1X .125W F TC0+100	24546	C4=1/8-T0=1111-F
A5R345	0698-3202	9	1	RESISTOR 1.74K 1X .125W F TC0+100	24546	C4=1/8-T0=1741-F
A5R346	0757-0394	0		RESISTOR 51.1 1X .125W F TC0+100	24546	C4=1/8-T0=51R1-F
A5R347	0757-0274	5		RESISTOR 1.21K 1X .125W F TC0+100	24546	C4=1/8-T0=1213-F
A5R348	0757-0407	6		RESISTOR 200 1X .125W F TC0+100	24546	C4=1/8-T0=2011-F
A5R349	0698-4428	3		RESISTOR 1.69K 1X .125W F TC0+100	24546	C4=1/8-T0=1691-F
A5R351	0698-4425	0		RESISTOR 1.54K 1X .125W F TC0+100	24546	C4=1/8-T0=1541-F
A5R352	0757-0280	3		RESISTOR 1K 1X .125W F TC0+100	24546	C4=1/8-T0=1001-F
A5R353	0698-3178	8		RESISTOR 487 1X .125W F TC0+100	24546	C4=1/8-T0=487R-F
A5R354	0698-3178	8		RESISTOR 487 1X .125W F TC0+100	24546	C4=1/8-T0=487R-F
A5R355	0757-0407	6		RESISTOR 200 1X .125W F TC0+100	24546	C4=1/8-T0=2011-F
A5R356	0698-3437	2		RESISTOR 133 1X .125W F TC0+100	24546	C4=1/8-T0=133R-F
A5R357	0698-4386	2	2	RESISTOR 59 1X .125W F TC0+100	24546	C4=1/8-T0=59R0-F
A5R358	0698-4386	2		RESISTOR 59 1X .125W F TC0+100	24546	C4=1/8-T0=59R0-F
A5R359	0698-7229	8	2	RESISTOR 511 1X .05W F TC0+100	24546	C3=1/8-T0=511R-G
A5R361	0698-7229	8		RESISTOR 511 1X .05W F TC0+100	24546	C3=1/8-T0=511R-G
A5R362	0757-0401	0		RESISTOR 100 1X .125W F TC0+100	24546	C4=1/8-T0=1011-F
A5R363	0757-0346	2		RESISTOR 10 1X .125W F TC0+100	24546	C4=1/8-T0=10R0-F
A5R364	0757-0401	0		RESISTOR 100 1X .125W F TC0+100	24546	C4=1/8-T0=1011-F
A5R365	0757-0401	0		RESISTOR 100 1X .125W F TC0+100	24546	C4=1/8-T0=1011-F
A5R366	0757-0438	3		RESISTOR 5.11K 1X .125W F TC0+100	24546	C4=1/8-T0=5111-F
A5R367	0698-3442	9		RESISTOR 237 1X .125W F TC0+100	24546	C4=1/8-T0=237R-F
A5R401	0698-3111	9		RESISTOR 30 5X .125W CC TC=-270/+540	01121	RB3005
A5R402	0757-0274	5		RESISTOR 1.21K 1X .125W F TC0+100	24546	C4=1/8-T0=1213-F
A5R403	0698-3111	9		RESISTOR 30 5X .125W CC TC=-270/+540	01121	RB3005
A5R404	0698-3374	6		RESISTOR 20 5X .125W CC TC=-270/+540	01121	RB2005
A5R405	0757-1094	9		RESISTOR 1.47K 1X .125W F TC0+100	24546	C4=1/8-T0=1471-F
A5R406	0757-0402	1		RESISTOR 110 1X .125W F TC0+100	24546	C4=1/8-T0=1111-F
A5R407	0757-0402	1		RESISTOR 110 1X .125W F TC0+100	24546	C4=1/8-T0=1111-F
A5R408	0698-4422	7		RESISTOR 1.27K 1X .125W F TC0+100	24546	C4=1/8-T0=1271-F
A5R409	0757-0401	0		RESISTOR 100 1X .125W F TC0+100	24546	C4=1/8-T0=1011-F
A5R410	0757-0401	0		RESISTOR 100 1X .125W F TC0+100	24546	C4=1/8-T0=1011-F
A5R411	0698-4037	0	6	RESISTOR 46.4 1X .125W F TC0+100	24546	C4=1/8-T0=46R4-F
A5R412	0698-4037	0		RESISTOR 46.4 1X .125W F TC0+100	24546	C4=1/8-T0=46R4-F
A5R413	0698-7205	0		RESISTOR 51.1 1X .05W F TC0+100	24546	C3=1/8-T0=51R1-G
A5R414	0698-7205	0		RESISTOR 51.1 1X .05W F TC0+100	24546	C3=1/8-T0=51R1-G
A5R415	0698-4037	0		RESISTOR 46.4 1X .125W F TC0+100	24546	C4=1/8-T0=46R4-F
A5R416	0698-4037	0		RESISTOR 46.4 1X .125W F TC0+100	24546	C4=1/8-T0=46R4-F
A5R417	0757-0388	2		RESISTOR 30.1 1X .125W F TC0+100	24546	C4=1/8-T0=30R1-F
A5R418	0757-0394	0		RESISTOR 51.1 1X .125W F TC0+100	24546	C4=1/8-T0=51R1-F
A5R419	0698-4383	9	2	RESISTOR 53.6 1X .125W F TC0+100	24546	C4=1/8-T0=53R6-F
A5R420	0698-4383	9		RESISTOR 53.6 1X .125W F TC0+100	24546	C4=1/8-T0=53R6-F
A5R421	0698-0271	7	1	RESISTOR 2.7 10X .25W FC TC=400/+500	01121	CB27G1
A5R425	0698-4428	3		RESISTOR 1.69K 1X .125W F TC0+100	24546	C4=1/8-T0=1691-F
A5R426	0698-4458	9		RESISTOR 590 1X .125W F TC0+100	24546	C4=1/8-T0=590R-F
A5R427	0698-3258	5		RESISTOR 5.36K 1X .125W F TC0+100	24546	C4=1/8-T0=5361-F
A5R428	0757-0407	6		RESISTOR 200 1X .125W F TC0+100	24546	C4=1/8-T0=2011-F
A5R429	0698-4428	3		RESISTOR 1.69K 1X .125W F TC0+100	24546	C4=1/8-T0=1691-F
A5R431	0757-0274	5		RESISTOR 1.21K 1X .125W F TC0+100	24546	C4=1/8-T0=1213-F
A5R432	0757-0394	0		RESISTOR 51.1 1X .125W F TC0+100	24546	C4=1/8-T0=51R1-F
A5R501	0757-0449	6		RESISTOR 20K 1X .125W F TC0+100	24546	C4=1/8-T0=2002-F
A5R502	0757-0449	6		RESISTOR 20K 1X .125W F TC0+100	24546	C4=1/8-T0=2002-F
A5R503	0757-0449	6		RESISTOR 20K 1X .125W F TC0+100	24546	C4=1/8-T0=2002-F
A5R504	0757-0438	3		RESISTOR 5.11K 1X .125W F TC0+100	24546	C4=1/8-T0=5111-F
A5R505	0757-0438	3		RESISTOR 5.11K 1X .125W F TC0+100	24546	C4=1/8-T0=5111-F
A5R506	0757-0442	9		RESISTOR 10K 1X .125W F TC0+100	24546	C4=1/8-T0=1002-F
A5R507	0757-0442	9		RESISTOR 10K 1X .125W F TC0+100	24546	C4=1/8-T0=1002-F
A5R508	0757-0442	9		RESISTOR 10K 1X .125W F TC0+100	24546	C4=1/8-T0=1002-F
A5R509	0698-4428	3		RESISTOR 1.69K 1X .125W F TC0+100	24546	C4=1/8-T0=1691-F
A5R510	0698-3136	8	9	RESISTOR 17.8K 1X .125W F TC0+100	24546	C4=1/8-T0=17R2-F
A5R511	0757-0283	6		RESISTOR 2K 1X .125W F TC0+100	24546	C4=1/8-T0=2001-F
A5R512	0757-0421	4		RESISTOR 825 1X .125W F TC0+100	24546	C4=1/8-T0=825R-F
A5R513	0757-0442	9		RESISTOR 10K 1X .125W F TC0+100	24546	C4=1/8-T0=1002-F
A5R514	0698-3499	6		RESISTOR 40.2K 1X .125W F TC0+100	24546	C4=1/8-T0=4022-F
A5R515	0757-0442	9		RESISTOR 10K 1X .125W F TC0+100	24546	C4=1/8-T0=1002-F

Table 6-3. Replaceable Parts (cont'd)

Reference Designation	HP Part Number	C D	Qty	Description	Mfr Code	Mfr Part Number	
A5R516	0698-4453	4	3	RESISTOR 402 1% .125W F TC=0+-100	24546	C4=1/8-T0=402R-F	
A5R517	0757-0280	3		RESISTOR 1K 1% .125W F TC=0+-100	24546	C4=1/8-T0=1001-F	
A5R51A	06R3-1065	7		RESISTOR 10M 5% .25W FC TC=900/+1100	01121	C81065	
A5R520	069A-71A8	8		RESISTOR 10 1% .05W F TC=0+-100	24546	C3=1/8-T00=10R=G	
A5R521	0757-0280	3		RESISTOR 1K 1% .125W F TC=0+-100	24546	C4=1/8-T0=1001-F	
A5R523	069A-71A8	8	RESISTOR 10 1% .05W F TC=0+-100	24546	C3=1/8-T00=10R=G		
A5R524	0757-0280	3	RESISTOR 1K 1% .125W F TC=0+-100	24546	C4=1/8-T0=1001-F		
A5R525	0757-0438	3	RESISTOR 5.11K 1% .125W F TC=0+-100	24546	C4=1/8-T0=5111-F		
A5R526	0757-0438	3	RESISTOR 5.11K 1% .125W F TC=0+-100	24546	C4=1/8-T0=5111-F		
A5R527	0757-0442	9	RESISTOR 10K 1% .125W F TC=0+-100	24546	C4=1/8-T0=1002-F		
A5R528	0757-0442	9	RESISTOR 10K 1% .125W F TC=0+-100	24546	C4=1/8-T0=1002-F		
A5R529	0757-0442	9	RESISTOR 10K 1% .125W F TC=0+-100	24546	C4=1/8-T0=1002-F		
A5R601	0757-0442	9	RESISTOR 10K 1% .125W F TC=0+-100	24546	C4=1/8-T0=1002-F		
A5R602	0757-0280	3	RESISTOR 1K 1% .125W F TC=0+-100	24546	C4=1/8-T0=1001-F		
A5R603	0757-0280	3	RESISTOR 1K 1% .125W F TC=0+-100	24546	C4=1/8-T0=1001-F		
A5R701	1810-0049	7	2	NETWORK-RES 12-SIP6.8K OHM X 10	28480	1810-0049	
A5R702	1810-0049	7		NETWORK-RES 12-SIP6.8K OHM X 10	28480	1810-0049	
A5R71	0637-0085	6	1	THERMISTOR ROD 680-OHM TC=+.7%/C-DEG	28480	0637-0085	
A5U1	1826-0059	2	9	IC OP AMP GP T0=99	01295	LW201AL	
A5U2	1826-0059	2		IC OP AMP GP T0=99	01295	LW201AL	
A5U3	1826-0059	2		IC OP AMP GP T0=99	01295	LW201AL	
A5U4	1826-0147	9		1	IC 7812 V RGLTR T0=220	04713	MC7812CP
A5U5	1826-0315	3		IC OP AMP GP GUAD 14=DIP-P	27014	LM348N	
A5U6	1826-0043	4	6	IC OP AMP GP T0=99	01928	CA307T	
A5U101	1820-0802	1		IC GATE ECL NOR GUAD 2=INP	04713	MC10102P	
A5U201	1820-0751	9		1	IC CNTR TTL DECD NEG-EDGE=TRIG PRESET	01295	8N74196N
A5U202	1820-0802	1		IC GATE ECL NOR GUAD 2=INP	04713	MC10102P	
A5U301	1858-0040	8		3	TRANSISTOR ARRAY	01928	CA3127E
A5U302	1858-0040	8	11	TRANSISTOR ARRAY	01928	CA3127E	
A5U303	1858-0040	8		TRANSISTOR ARRAY	01928	CA3127E	
A5U304	1826-0043	4		IC OP AMP GP T0=99	01928	CA307T	
A5U305	1826-0043	4		IC OP AMP GP T0=99	01928	CA307T	
A5U306	1826-0111	7		IC OP AMP GP DUAL T0=99	04713	MC1458G	
A5U401	1858-0030	6	1	TRANSISTOR ARRAY 16-PIN CER DIP	28480	1858-0030	
A5U402	1826-0111	7	0	IC OP AMP GP DUAL T0=99	04713	MC1458G	
A5U601	1826-0081	7		1	IC OP AMP WB T0=99	27014	LM318M
A5VR1	1902-3024	9	2	DIODE-ZNR 2.87V 5% DO-7 PDM.4W TC=-.07%	28480	1902-3024	
A5VR2	1902-0032	3		DIODE-ZNR 5.49V 5% DO-7 PDM.4W TC=+.009%	28480	1902-0032	
A5VR3	1902-0032	3		DIODE-ZNR 5.49V 5% DO-7 PDM.4W TC=+.009%	28480	1902-0032	
A5VR4	1902-0032	3		DIODE-ZNR 5.49V 5% DO-7 PDM.4W TC=+.009%	28480	1902-0032	
A5VR5	1902-3024	9		DIODE-ZNR 2.87V 5% DO-7 PDM.4W TC=-.07%	28480	1902-3024	
A5VR6	1902-3094	3	1	DIODE-ZNR 5.11V 2% DO-7 PDM.4W TC=-.009%	28480	1902-3094	
A5VR7	1902-0692	1		DIODE-ZNR 6.3V 1% DO-7 PDM.4W TC=+.001%	28480	1902-0692	
A5VR8	1902-3002	3		DIODE-ZNR 2.37V 5% DO-7 PDM.4W TC=-.074%	28480	1902-3002	
A5VR9	1902-0685	2		1	DIODE-ZNR 9V 2% DO-7 PDM.5W TC=+.001%	28480	1902-0685
A5VR101	1902-0048	1		DIODE-ZNR 6.81V 5% DO-7 PDM.4W TC=+.043%	28480	1902-0048	
A5VR102	1902-0041	4	6	DIODE-ZNR 5.11V 5% DO-7 PDM.4W TC=-.009%	28480	1902-0041	
A5VR103	1902-3149	9		DIODE-ZNR 9.09V 5% DO-7 PDM.4W TC=+.057%	28480	1902-3149	
A5VR104	1902-0126	6		3	DIODE-ZNR 2.61V 5% DO-7 PDM.4W TC=-.072%	28480	1902-0126
A5VR201	1902-0126	6		DIODE-ZNR 2.61V 5% DO-7 PDM.4W TC=-.072%	28480	1902-0126	
A5VR202	1902-0126	6		DIODE-ZNR 2.61V 5% DO-7 PDM.4W TC=-.072%	28480	1902-0126	
A5VR203	1902-0786	4	7	DIODE-ZNR 1N937 9V 5% DO-7 PDM.5W	24046	1N937	
A5VR301	1902-0786	4		DIODE-ZNR 1N937 9V 5% DO-7 PDM.5W	24046	1N937	
A5VR302	1902-0786	4		DIODE-ZNR 1N937 9V 5% DO-7 PDM.5W	24046	1N937	
A5VR401	1902-3094	3		DIODE-ZNR 5.11V 2% DO-7 PDM.4W TC=-.009%	28480	1902-3094	
A5VR402	1902-0777	3		2	DIODE-ZNR 1N825 6.2V 5% DO-7 PDM.4W	04713	1N825
A6	08165-66506	9	1	BOARD ASSEMBLY, POWER CONTROL	28480	08165-66506	
A6C101	0160-3650	2	1	CAPACITOR-FXD .018UF +-10% 50VDC CER	28480	0160-3650	
A6C102	0160-0174	9		CAPACITOR-FXD .47UF +80-20% 25VDC CER	28480	0160-0174	
A6C103	0160-2265	3		1	CAPACITOR-FXD 22PF +-5% 500VDC CER 0+-30	28480	0160-2265
A6C104	0160-3879	7		CAPACITOR-FXD .01UF +-20% 100VDC CER	28480	0160-3879	
A6C105	0180-1704	5		CAPACITOR-FXD 47UF+-10% 6VDC TA	56289	150D476X900682	
A6C201	0160-0174	9	5	CAPACITOR-FXD .47UF +80-20% 25VDC CER	28480	0160-0174	
A6C202	0160-1704	5		CAPACITOR-FXD 47UF+-10% 6VDC TA	56289	150D476X900682	
A6C301	0160-0174	9		CAPACITOR-FXD .47UF +80-20% 25VDC CER	28480	0160-0174	
A6C302	0160-2257	3		3	CAPACITOR-FXD 10PF +-5% 500VDC CER 0+-60	28480	0160-2257
A6C303	0180-0116	1		5	CAPACITOR-FXD 6.8UF+-10% 35VDC TA	56289	150D685X903582
A6C401	0160-0174	9	3	CAPACITOR-FXD .47UF +80-20% 25VDC CER	28480	0160-0174	
A6C402	0160-2257	3		CAPACITOR-FXD 10PF +-5% 500VDC CER 0+-60	28480	0160-2257	
A6C403	0180-0116	1		CAPACITOR-FXD 6.8UF+-10% 35VDC TA	56289	150D685X903582	
A6C501	0160-2055	9		CAPACITOR-FXD .01UF +80-20% 100VDC CER	28480	0160-2055	
A6C502	0180-0291	3		1	CAPACITOR-FXD 1UF+-10% 35VDC TA	56289	150D105X9035A2

Table 6-3. Replaceable Parts (cont'd)

Reference Designation	HP Part Number	C D	Qty	Description	Mfr Code	Mfr Part Number
A6C503	0160-0229	7		CAPACITOR-FXD 33UF +-10% 10VDC TA	56289	150D336X901082
A6C505	0160-0174	9		CAPACITOR-FXD .47UF +80-20% 25VDC CER	28480	0160-0174
A6C506	0160-0174	9		CAPACITOR-FXD .47UF +80-20% 25VDC CER	28480	0160-0174
A6C601	0160-0174	9		CAPACITOR-FXD .47UF +80-20% 25VDC CER	28480	0160-0174
A6C602	0160-2150	5		CAPACITOR-FXD 33PF +-5% 300VDC MICA	28480	0160-2150
A6C803	0160-4212	4		CAPACITOR-FXD .068UF +-20% 50VDC POLYE	28480	0160-4212
A6C801	0160-0196	3		CAPACITOR-FXD 150PF +-5% 300VDC MICA	72136	DM15F151J0300RV1CR
A6CR101	1901-0040	1		DIODE-SWITCHING 30V 50MA 2NS DO-35	28480	1901-0040
A6CR201	1901-0040	1		DIODE-SWITCHING 30V 50MA 2NS DO-35	28480	1901-0040
A6CR301	1901-0040	1		DIODE-SWITCHING 30V 50MA 2NS DO-35	28480	1901-0040
A6CR401	1901-0040	1		DIODE-SWITCHING 30V 50MA 2NS DO-35	28480	1901-0040
A6CR501	1901-0044	5	23	DIODE-SWITCHING 50V 50MA 6NS	28480	1901-0044
A6CR502	1901-0044	5		DIODE-SWITCHING 50V 50MA 6NS	28480	1901-0044
A6CR503	1901-0044	5		DIODE-SWITCHING 50V 50MA 6NS	28480	1901-0044
A6CR504	1901-0044	5		DIODE-SWITCHING 50V 50MA 6NS	28480	1901-0044
A6CR505	1901-0044	5		DIODE-SWITCHING 50V 50MA 6NS	28480	1901-0044
A6CR506	1901-0050	3		DIODE-SWITCHING 80V 200MA 2NS DO-35	28480	1901-0050
A6CR507	1901-0050	3		DIODE-SWITCHING 80V 200MA 2NS DO-35	28480	1901-0050
A6CR601	1901-0044	5		DIODE-SWITCHING 50V 50MA 6NS	28480	1901-0044
A6CR602	1901-0044	5		DIODE-SWITCHING 50V 50MA 6NS	28480	1901-0044
A6CR603	1901-0044	5		DIODE-SWITCHING 50V 50MA 6NS	28480	1901-0044
A6CR604	1901-0044	5		DIODE-SWITCHING 50V 50MA 6NS	28480	1901-0044
A6CR801	1901-0040	1		DIODE-SWITCHING 30V 50MA 2NS DO-35	28480	1901-0040
A6CR802	1901-0040	1		DIODE-SWITCHING 30V 50MA 2NS DO-35	28480	1901-0040
A6CR803	1901-0040	1		DIODE-SWITCHING 30V 50MA 2NS DO-35	28480	1901-0040
A6CR804	1901-0040	1		DIODE-SWITCHING 30V 50MA 2NS DO-35	28480	1901-0040
A6CR805	1901-0040	1		DIODE-SWITCHING 30V 50MA 2NS DO-35	28480	1901-0040
A6MP1	1205-0264	9	1	HEAT SINK PLSTC-PWR-CB	28480	1205-0264
A6MP2	4040-0753	0	1	EXTR-PC BD GRN POLYC .062-80-THKNS	28480	4040-0753
A6Q101	1853-0212	6	1	TRANSISTOR PNP 2N5194 SI PD=40W FT=2MHZ	04713	2N5194
A6Q102	1854-0477	9		TRANSISTOR NPN 2N2222A SI TO-18 PD=500MW	04713	2N2222A
A6Q201	1853-0281	9		TRANSISTOR PNP 2N2907A SI TO-18 PD=400MW	04713	2N2907A
A6Q301	1854-0637	1		TRANSISTOR NPN 2N2219A SI TO-5 PD=800MW	01295	2N2219A
A6Q401	1853-0314	9		TRANSISTOR PNP 2N2905A SI TO-39 PD=600MW	04713	2N2905A
A6Q501	1854-0637	1		TRANSISTOR NPN 2N2219A SI TO-5 PD=800MW	01295	2N2219A
A6Q502	1853-0314	9		TRANSISTOR PNP 2N2905A SI TO-39 PD=600MW	04713	2N2905A
A6Q503	1854-0477	7		TRANSISTOR NPN 2N2222A SI TO-18 PD=500MW	04713	2N2222A
A6Q504	1853-0281	9		TRANSISTOR PNP 2N2907A SI TO-18 PD=400MW	04713	2N2907A
A6Q601	1853-0036	2		TRANSISTOR PNP SI PD=310MW FT=250MHZ	28480	1853-0036
A6Q602	1853-0036	2		TRANSISTOR PNP SI PD=310MW FT=250MHZ	28480	1853-0036
A6Q603	1853-0036	2		TRANSISTOR PNP SI PD=310MW FT=250MHZ	28480	1853-0036
A6Q604	1855-0081	1	7	TRANSISTOR J-FET N-CHAN D-MODE SI	01295	2N5245
A6Q605	1855-0081	1		TRANSISTOR J-FET N-CHAN D-MODE SI	01295	2N5245
A6Q606	1855-0081	1		TRANSISTOR J-FET N-CHAN D-MODE SI	01295	2N5245
A6Q607	1854-0472	2		TRANSISTOR NPN SI DARL PD=500MW	04713	MP8-A14
A6Q801	1853-0400	4		TRANSISTOR PNP SI DARL TO-92 PD=500MW	28480	1853-0400
A6Q802	1853-0036	2	6	TRANSISTOR PNP SI PD=310MW FT=250MHZ	28480	1853-0036
A6Q803	1853-0036	2		TRANSISTOR PNP SI PD=310MW FT=250MHZ	28480	1853-0036
A6Q804	1854-0215	1		TRANSISTOR NPN SI PD=350MW FT=300MHZ	04713	2N3904
A6Q906	1853-0400	4		TRANSISTOR PNP SI DARL TO-92 PD=500MW	28480	1853-0400
A6Q907	1853-0400	4		TRANSISTOR PNP SI DARL TO-92 PD=500MW	28480	1853-0400
A6Q908	1853-0086	2		TRANSISTOR PNP SI PD=310MW FT=400MHZ	27014	2N5087
A6Q909	1853-0281	9		TRANSISTOR PNP 2N2907A SI TO-18 PD=400MW	04713	2N2907A
A6Q910	1853-0400	4		TRANSISTOR PNP SI DARL TO-92 PD=500MW	28480	1853-0400
A6Q911	1853-0086	2		TRANSISTOR PNP SI PD=310MW FT=400MHZ	27014	2N5087
A6Q912	1854-0637	1		TRANSISTOR NPN 2N2219A SI TO-5 PD=800MW	01295	2N2219A
A6Q913	1853-0281	9		TRANSISTOR PNP 2N2907A SI TO-18 PD=400MW	04713	2N2907A
A6R1	2100-3053	5	2	RESISTOR-TRMR 20 20% C SIDE-ADJ 17-TRN	02111	43P200
A6R2	2100-3053	5		RESISTOR-TRMR 20 20% C SIDE-ADJ 17-TRN	02111	43P200
A6R101	0757-0280	3		RESISTOR 1K 1% .125W F TC=0+-100	24546	C4=1/8-T0=1001-F
A6R102	0757-0280	3		RESISTOR 1K 1% .125W F TC=0+-100	24546	C4=1/8-T0=1001-F
A6R103	0757-0280	3		RESISTOR 1K 1% .125W F TC=0+-100	24546	C4=1/8-T0=1001-F
A6R104	0698-3444	1	3	RESISTOR 316 1% .125W F TC=0+-100	24546	C4=1/8-T0=316R-F
A6R105	0698-4389	5		RESISTOR 64.9 1% .125W F TC=0+-100	24546	C4=1/8-T0=64.9R-F
A6R106	0698-3445	2	1	RESISTOR 348 1% .125W F TC=0+-100	24546	C4=1/8-T0=348R-F
A6R107	0757-0346	2		RESISTOR 10 1% .125W F TC=0+-100	24546	C4=1/8-T0=10R0-F
A6R108	0757-0984	4	1	RESISTOR 10 1% .5W F TC=0+-100	28480	0757-0984
A6R109	0757-0280	3		RESISTOR 1K 1% .125W F TC=0+-100	24546	C4=1/8-T0=1001-F
A6R110	0757-0280	3		RESISTOR 1K 1% .125W F TC=0+-100	24546	C4=1/8-T0=1001-F
A6R111	0698-3159	5		RESISTOR 20.1K 1% .125W F TC=0+-100	24546	C4=1/8-T0=20.1K-F
A6R112	0698-3159	5		RESISTOR 20.1K 1% .125W F TC=0+-100	24546	C4=1/8-T0=20.1K-F
A6R201	0757-0280	3		RESISTOR 1K 1% .125W F TC=0+-100	24546	C4=1/8-T0=1001-F
A6R202	0757-0280	3		RESISTOR 1K 1% .125W F TC=0+-100	24546	C4=1/8-T0=1001-F
A6R203	0757-0280	3		RESISTOR 1K 1% .125W F TC=0+-100	24546	C4=1/8-T0=1001-F
A6R204	0757-0401	0		RESISTOR 100 1% .125W F TC=0+-100	24546	C4=1/8-T0=101-F
A6R205	0757-0280	3		RESISTOR 1K 1% .125W F TC=0+-100	24546	C4=1/8-T0=1001-F
A6R206	0757-0280	3		RESISTOR 1K 1% .125W F TC=0+-100	24546	C4=1/8-T0=1001-F

Table 6-3. Replaceable Parts (cont'd)

Reference Designation	HP Part Number	C D	Qty	Description	Mfr Code	Mfr Part Number
A6R207	0698-4486	3		RESISTOR 24.9K 1% .125W F TC0+100	24546	C4=1/B=TO=2492=F
A6R208	0698-4486	3		RESISTOR 24.9K 1% .125W F TC0+100	24546	C4=1/B=TO=2492=F
A6R301	0698-4471	6	4	RESISTOR 7.15K 1% .125W F TC0+100	24546	C4=1/B=TO=7151=F
A6R302	2100-3351	6	4	RESISTOR-TMR 500 10% C SIDE-ADJ 1-TRN	26480	2100-3351
A6R303	0698-4433	6	10	RESISTOR 2.26K 1% .125W F TC0+100	24546	C4=1/B=TO=2261=F
A6R304	0698-4433	0		RESISTOR 2.26K 1% .125W F TC0+100	24546	C4=1/B=TO=2261=F
A6R305	0698-4442	1	4	RESISTOR 4.42K 1% .125W F TC0+100	24546	C4=1/B=TO=4421=F
A6R306	0757-3260	3		RESISTOR 1K 1% .125W F TC0+100	24546	C4=1/B=TO=1001=F
A6R307	0757-0718	2	4	RESISTOR 200 1% .25W F TC0+100	24546	C5=1/4=TO=201=F
A6R308	0757-0280	3		RESISTOR 1K 1% .125W F TC0+100	24546	C4=1/B=TO=1001=F
A6R309	0757-0280	3		RESISTOR 1K 1% .125W F TC0+100	24546	C4=1/B=TO=1001=F
A6R310	0698-3158	4	5	RESISTOR 23.7K 1% .125W F TC0+100	24546	C4=1/B=TO=2372=F
A6R311	0698-3158	4		RESISTOR 23.7K 1% .125W F TC0+100	24546	C4=1/B=TO=2372=F
A6R312	0757-0718	2		RESISTOR 200 1% .25W F TC0+100	24546	C5=1/4=TO=201=F
A6R401	0698-4471	6		RESISTOR 7.15K 1% .125W F TC0+100	24546	C4=1/B=TO=7151=F
A6R402	2100-3351	6		RESISTOR-TMR 500 10% C SIDE-ADJ 1-TRN	26480	2100-3351
A6R403	0698-4433	6		RESISTOR 2.26K 1% .125W F TC0+100	24546	C4=1/B=TO=2261=F
A6R404	0698-4433	0		RESISTOR 2.26K 1% .125W F TC0+100	24546	C4=1/B=TO=2261=F
A6R405	0698-4442	1		RESISTOR 4.42K 1% .125W F TC0+100	24546	C4=1/B=TO=4421=F
A6R406	0757-0280	3		RESISTOR 1K 1% .125W F TC0+100	24546	C4=1/B=TO=1001=F
A6R407	0757-0718	2		RESISTOR 200 1% .25W F TC0+100	24546	C5=1/4=TO=201=F
A6R408	0698-5449	0	5	RESISTOR 5K .1% .125W F TC0+50	19701	MF4C1/B=T2=5001-B
A6R409	0698-5449	0		RESISTOR 5K .1% .125W F TC0+50	19701	MF4C1/B=T2=5001-B
A6R410	0698-6943	1	1	RESISTOR 20K .1% .125W F TC0+50	26480	0698-6943
A6R411	0698-3451	0	4	RESISTOR 133K 1% .125W F TC0+100	24546	C4=1/B=TO=1333=F
A6R412	0698-6608	5	2	RESISTOR 23.5K .1% .125W F TC0+25	26480	0698-6608
A6R413	0757-0718	2		RESISTOR 200 1% .25W F TC0+100	24546	C5=1/4=TO=201=F
A6R501	0698-3226	7	2	RESISTOR 6.49K 1% .125W F TC0+100	24546	C4=1/B=TO=6491=F
A6R502	0698-4453	4		RESISTOR 402 1% .125W F TC0+100	24546	C4=1/B=TO=402R=F
A6R503	0698-3226	7		RESISTOR 6.49K 1% .125W F TC0+100	24546	C4=1/B=TO=6491=F
A6R504	0698-4453	4		RESISTOR 402 1% .125W F TC0+100	24546	C4=1/B=TO=402R=F
A6R505	0757-0271	2	1	RESISTOR 124K 1% .125W F TC0+100	24546	C4=1/B=TO=1243=F
A6R506	0757-0444	1		RESISTOR 12.1K 1% .125W F TC0+100	24546	C4=1/B=TO=1212=F
A6R507	0757-0442	1		RESISTOR 10K 1% .125W F TC0+100	24546	C4=1/B=TO=1002=F
A6R508	0698-3449	6	1	RESISTOR 28.7K 1% .125W F TC0+100	24546	C4=1/B=TO=2872=F
A6R509	0698-4521	7	2	RESISTOR 154K 1% .125W F TC0+100	24546	C4=1/B=TO=1543=F
A6R510	0757-0280	3		RESISTOR 1K 1% .125W F TC0+100	24546	C4=1/B=TO=1001=F
A6R511	0757-0280	3		RESISTOR 1K 1% .125W F TC0+100	24546	C4=1/B=TO=1001=F
A6R512	0757-0346	2		RESISTOR 10 1% .125W F TC0+100	24546	C4=1/B=TO=100R=F
A6R513	0757-0419	0		RESISTOR 661 1% .125W F TC0+100	24546	C4=1/B=TO=661R=F
A6R514	0698-0085	0		RESISTOR 2.61K 1% .125W F TC0+100	24546	C4=1/B=TO=2611=F
A6R515	0698-0083	8	3	RESISTOR 1.46K 1% .125W F TC0+100	24546	C4=1/B=TO=1461=F
A6R516	2100-3351	6		RESISTOR-TMR 500 10% C SIDE-ADJ 1-TRN	26480	2100-3351
A6R517	0698-3259	6	2	RESISTOR 7.67K 1% .125W F TC0+100	24546	C4=1/B=TO=7671=F
A6R518	0698-4429	4		RESISTOR 1.67K 1% .125W F TC0+100	24546	C4=1/B=TO=1671=F
A6R519	0757-0288	1	2	RESISTOR 9.09K 1% .125W F TC0+100	19701	MF4C1/B=TO=9091=F
A6R520	0757-0439	4		RESISTOR 6.81K 1% .125W F TC0+100	24546	C4=1/B=TO=6811=F
A6R521	0698-4442	1		RESISTOR 4.42K 1% .125W F TC0+100	24546	C4=1/B=TO=4421=F
A6R522	0757-0458	7		RESISTOR 51.1K 1% .125W F TC0+100	24546	C4=1/B=TO=5112=F
A6R523	2100-3351	6		RESISTOR-TMR 500 10% C SIDE-ADJ 1-TRN	26480	2100-3351
A6R601	2100-3350	5	3	RESISTOR-TMR 200 10% C SIDE-ADJ 1-TRN	26480	2100-3350
A6R602	0757-0422	5	3	RESISTOR 909 1% .125W F TC0+100	24546	C4=1/B=TO=909R=F
A6R603	0757-0280	3		RESISTOR 1K 1% .125W F TC0+100	24546	C4=1/B=TO=1001=F
A6R604	0757-0454	3		RESISTOR 33.2K 1% .125W F TC0+100	24546	C4=1/B=TO=3322=F
A6R605	0757-0458	7		RESISTOR 51.1K 1% .125W F TC0+100	24546	C4=1/B=TO=5112=F
A6R606	0757-0454	3		RESISTOR 33.2K 1% .125W F TC0+100	24546	C4=1/B=TO=3322=F
A6R607	0757-0458	7		RESISTOR 51.1K 1% .125W F TC0+100	24546	C4=1/B=TO=5112=F
A6R609	0757-0442	9		RESISTOR 10K 1% .125W F TC0+100	24546	C4=1/B=TO=1002=F
A6R610	2100-3356	1	1	RESISTOR-TMR 200K 10% C SIDE-ADJ 1-TRN	26480	2100-3356
A6R611	0698-4521	7		RESISTOR 154K 1% .125W F TC0+100	24546	C4=1/B=TO=1543=F
A6R612	0698-4444	3		RESISTOR 4.87K 1% .125W F TC0+100	24546	C4=1/B=TO=4871=F
A6R613	0698-4442	1		RESISTOR 4.42K 1% .125W F TC0+100	24546	C4=1/B=TO=4421=F
A6R614	2100-3352	7	2	RESISTOR-TMR 1K 10% C SIDE-ADJ 1-TRN	26480	2100-3352
A6R615	0757-0274	5		RESISTOR 1.21K 1% .125W F TC0+100	24546	C4=1/B=TO=1213=F
A6R616	0757-0438	3		RESISTOR 5.11K 1% .125W F TC0+100	24546	C4=1/B=TO=5111=F
A6R617	0698-5049	0		RESISTOR 5K .1% .125W F TC0+50	19701	MF4C1/B=T2=5001-B
A6R618	0698-3158	4		RESISTOR 23.7K 1% .125W F TC0+100	24546	C4=1/B=TO=2372=F
A6R618	0698-5449	0		RESISTOR 5K .1% .125W F TC0+50	19701	MF4C1/B=T2=5001-B
A6R619	0698-5449	0		RESISTOR 5K .1% .125W F TC0+50	19701	MF4C1/B=T2=5001-B
A6R601	0698-3152	8		RESISTOR 3.48K 1% .125W F TC0+100	24546	C4=1/B=TO=3481=F
A6R602	0698-3152	8		RESISTOR 3.48K 1% .125W F TC0+100	24546	C4=1/B=TO=3481=F
A6R603	0757-1094	9		RESISTOR 1.47K 1% .125W F TC0+100	24546	C4=1/B=TO=1471=F
A6R604	0698-4425	0		RESISTOR 1.54K 1% .125W F TC0+100	24546	C4=1/B=TO=1541=F
A6R605	2100-3154	7	4	RESISTOR-TMR 1K 10% C SIDE-ADJ 1-TRN	02111	43P102
A6R607	0757-0280	3		RESISTOR 1K 1% .125W F TC0+100	24546	C4=1/B=TO=1001=F

Table 6-3. Replaceable Parts (cont'd)

Reference Designation	HP Part Number	C D	Qty	Description	Mfr Code	Mfr Part Number
A6R808	0698-4409	0		RESISTOR 127 1X .125W F TC0+100	24546	C4-1/8-T0-127R-F
A6R809	0698-3495	2		RESISTOR 866 1X .125W F TC0+100	24546	C4-1/8-T0-866R-F
A6R810	2100-3103	6	6	RESISTOR-TRMR 10K 10X C SIDE=ADJ 17-TRN	02111	43P103
A6R811	0698-4470	5	1	RESISTOR 6.98K 1X .125W F TC0+100	24546	C4-1/8-T0-6981-F
A6R812	0698-3156	2	6	RESISTOR 14.7K 1X .125W F TC0+100	24546	C4-1/8-T0-1472-F
A6R813	0757-0411	2	6	RESISTOR 332 1X .125W F TC0+100	24546	C4-1/8-T0-332R-F
A6R814	0757-0280	3		RESISTOR 1K 1X .125W F TC0+100	24546	C4-1/8-T0-1001-F
A6R815	0757-0442	9		RESISTOR 10K 1X .125W F TC0+100	24546	C4-1/8-T0-1002-F
A6R816	0698-3150	6	3	RESISTOR 2.37K 1X .125W F TC0+100	24546	C4-1/8-T0-2371-F
A6R817	0698-4458	9		RESISTOR 590 1X .125W F TC0+100	24546	C4-1/8-T0-590R-F
A6R818	0698-4467	0	1	RESISTOR 1.05K 1X .125W F TC0+100	24546	C4-1/8-T0-1051-F
A6R819	0698-3446	3	1	RESISTOR 383 1X .125W F TC0+100	24546	C4-1/8-T0-383R-F
A6R820	0698-3440	7	1	RESISTOR 196 1X .125W F TC0+100	24546	C4-1/8-T0-196R-F
A6R821	0757-0401	0		RESISTOR 100 1X .125W F TC0+100	24546	C4-1/8-T0-101-F
A6R822	0698-3150	6		RESISTOR 2.37K 1X .125W F TC0+100	24546	C4-1/8-T0-2371-F
A6R823	0757-0424	7		RESISTOR 1.1K 1X .125W F TC0+100	24546	C4-1/8-T0-1101-F
A6R824	0757-0438	3		RESISTOR 5.11K 1X .125W F TC0+100	24546	C4-1/8-T0-5111-F
A6R825	0757-0283	6		RESISTOR 2K 1X .125W F TC0+100	24546	C4-1/8-T0-2001-F
A6R826	2100-3207	1	5	RESISTOR-TRMR 5K 10X C 8IDE=ADJ 1-TRN	28480	2100-3207
A6R909	0698-3259	6		RESISTOR 7.87K 1X .125W F TC0+100	24546	C4-1/8-T0-7871-F
A6R910	0698-3154	0		RESISTOR 4.22K 1X .125W F TC0+100	24546	C4-1/8-T0-4221-F
A6R911	0757-0280	3		RESISTOR 1K 1X .125W F TC0+100	24546	C4-1/8-T0-1001-F
A6R912	2100-3056	8	2	RESISTOR-TRMR 5K 10X C 8IDE=ADJ 17-TRN	02111	43P502
A6R913	0757-0280	3		RESISTOR 1K 1X .125W F TC0+100	24546	C4-1/8-T0-1001-F
A6R914	0757-0280	3		RESISTOR 1K 1X .125W F TC0+100	24546	C4-1/8-T0-1001-F
A6R915	2100-3056	8		RESISTOR-TRMR 5K 10X C 8IDE=ADJ 17-TRN	02111	43P502
A6R916	0757-0280	3		RESISTOR 1K 1X .125W F TC0+100	24546	C4-1/8-T0-1001-F
A6R917	0757-0439	4		RESISTOR 6.81K 1X .125W F TC0+100	24546	C4-1/8-T0-6811-F
A6R918	0757-0442	9		RESISTOR 10K 1X .125W F TC0+100	24546	C4-1/8-T0-1002-F
A6R919	0757-0442	9		RESISTOR 10K 1X .125W F TC0+100	24546	C4-1/8-T0-1002-F
A6R920	2100-3103	6		RESISTOR-TRMR 10K 10X C SIDE=ADJ 17-TRN	02111	43P103
A6R921	0698-0083	8		RESISTOR 1.99K 1X .125W F TC0+100	24546	C4-1/8-T0-1961-F
A6R922	0757-0280	3		RESISTOR 1K 1X .125W F TC0+100	24546	C4-1/8-T0-1001-F
A6R923	0757-0439	4		RESISTOR 6.81K 1X .125W F TC0+100	24546	C4-1/8-T0-6811-F
A6R924	0757-0442	9		RESISTOR 10K 1X .125W F TC0+100	24546	C4-1/8-T0-1002-F
A6R925	0757-0442	9		RESISTOR 10K 1X .125W F TC0+100	24546	C4-1/8-T0-1002-F
A6R926	0757-0705	7	1	RESISTOR 47.5 1X .25W F TC0+100	28480	0757-0705
A6R927	0757-0346	2		RESISTOR 10 1X .125W F TC0+100	24546	C4-1/8-T0-10R0-F
A6U101	1826-0111	7		IC OP AMP GP DUAL T0-99	04713	MC1458G
A6U201	1826-0111	7		IC OP AMP GP DUAL T0-99	04713	MC1458G
A6U301	1826-0043	4		IC OP AMP GP T0-99	0192B	CA307T
A6U302	1826-0059	2		IC OP AMP GP T0-99	01295	LM201AL
A6U401	1826-0043	4		IC OP AMP GP T0-99	0192B	CA307T
A6U402	1826-0059	2		IC OP AMP GP T0-99	01295	LM201AL
A6U501	1826-0043	4		IC OP AMP GP T0-99	0192B	CA307T
A6U502	1826-0180	0	1	IC TIMER TTL MONO/ASTBL	04713	MC1455P1
A6U503	1826-0111	7		IC OP AMP GP DUAL T0-99	04713	MC1458G
A6U601	1826-0188	8	4	IC CONV 8-8-D/A 16-DIP-C	04713	MC1408L-8
A6U602	1826-0161	7	4	IC OP AMP GP QUAD 14-DIP-P	04713	MLM324P
A6U701	1820-1745	3	10	IC GATE CMOS NOR QUAD 2-INP	04713	MC14001BCP
A6U702	1820-1963	7	9	IC FF CMOS D-TYPE POS-EDGE-TRIG DUAL	0192B	CD40138AE
A6U703	1820-1956	8	20	IC LCH CMOS COM CLOCK QUAD	0192B	CD4042BE
A6U704	1820-1956	8		IC LCH CMOS COM CLOCK QUAD	0192B	CD4042BE
A6U705	1820-1956	8		IC LCH CMOS COM CLOCK QUAD	0192B	CD4042BE
A6U706	1820-1956	8		IC LCH CMOS COM CLOCK QUAD	0192B	CD4042BE
A6U707	1820-1976	2	6	IC BFR CMOS NON-INV HEX	0192B	CD4050BE
A6U708	1820-1976	2		IC BFR CMOS NON-INV HEX	0192B	CD4050BE
A6U710	1820-1745	3		IC GATE CMOS NOR QUAD 2-INP	04713	MC14001BCP
A6U711	1820-1956	6		IC LCH CMOS COM CLOCK QUAD	0192B	CD4042BE
A6U712	1820-1956	6		IC LCH CMOS COM CLOCK QUAD	0192B	CD4042BE
A6U713	1820-1956	8		IC LCH CMOS COM CLOCK QUAD	0192B	CD4042BE
A6U714	1820-1976	2		IC BFR CMOS NON-INV HEX	0192B	CD4050BE
A6U715	1820-1976	2		IC BFR CMOS NON-INV HEX	0192B	CD4050BE
A6U801	1826-0188	8		IC CONV 8-8-D/A 16-DIP-C	04713	MC1408L-8
A6U802	1826-0161	7		IC OP AMP GP QUAD 14-DIP-P	04713	MLM324P
A6U901	1826-0161	7		IC OP AMP GP QUAD 14-DIP-P	04713	MLM324P
A6VRS01	1902-3171	7	2	DIODE-ZNR 11V 5% DO-7 PDS .4W TC+ .062X	28480	1902-3171
A6VRS02	1902-3171	7		DIODE-ZNR 11V 5% DO-7 PDS .4W TC+ .062X	28480	1902-3171
A6VRS03	1902-0041	4		DIODE-ZNR 5.11V 5% DO-7 PDS .4W TC+ .009X	28480	1902-0041
A6VRS04	1902-0777	3		DIODE-ZNR 1N825 6.2V 5% DO-7 PDS .4W	04713	1N825
A6VRS05	1902-0041	4		DIODE-ZNR 5.11V 5% DO-7 PDS .4W TC+ .009X	28480	1902-0041
A6VRS02	1902-0786	4		DIODE-ZNR 1N937 9V 5% DO-7 PDS .5W	24046	1N937
A6VRS01	1902-0049	2	1	DIODE-ZNR 6.19V 5% DO-7 PDS .4W TC+ .022X	28480	1902-0049
A6VRS02	1902-0786	4		DIODE-ZNR 1N937 9V 5% DO-7 PDS .5W	24046	1N937
A6VRS03	1902-0025	4	0	DIODE-ZNR 10V 5% DO-7 PDS .4W TC+ .06X	28480	1902-0025
A6VRS04	1902-0025	4		DIODE-ZNR 10V 5% DO-7 PDS .4W TC+ .06X	28480	1902-0025

Table 6-3. Replaceable Parts (cont'd)

Reference Designation	HP Part Number	C D	Qty	Description	Mfr Code	Mfr Part Number
A7	0A165-66507	0	1	BOARD ASSEMBLY, INPUT MODULATOR	28480	0A165-66507
A7C1	0160-2241	5	1	CAPACITOR-FXD 2.2PF +-25PF 500VDC CER	28480	0160-2241
A7C2	0160-0574	3	2	CAPACITOR-FXD .022UF +-20% 100VDC CER	28480	0160-0574
A7C3	0160-0574	3		CAPACITOR-FXD .022UF +-20% 100VDC CER	28480	0160-0574
A7C4	0160-4213	5	3	CAPACITOR-FXD .1UF +-20% 50VDC POLYE	28480	0160-4213
A7C5	0160-0576	5		CAPACITOR-FXD .1UF +-20% 50VDC CER	28480	0160-0576
A7C6	0160-4210	2		CAPACITOR-FXD .022UF +-20% 50VDC POLYE	28480	0160-4210
A7C7	0160-2150	5		CAPACITOR-FXD 33PF +-5% 300VDC MICA	28480	0160-2150
A7C8	0160-3875	3		CAPACITOR-FXD 22PF +-5% 200VDC CER 0+-30	28480	0160-3875
A7C11	0160-2055	6		CAPACITOR-FXD .01UF +-20% 100VDC CER	28480	0160-2055
A7C12	0160-2999	7		CAPACITOR-FXD 2200PF +-20% 250VDC CER	56289	C067F251F222MS22=CDH
A7C14	0160-4210	2		CAPACITOR-FXD .022UF +-20% 50VDC POLYE	28480	0160-4210
A7C15	0160-0196	3		CAPACITOR-FXD 150PF +-5% 300VDC MICA	72136	DM15F151J0300WV1CR
A7C16	0160-4210	2		CAPACITOR-FXD .022UF +-20% 50VDC POLYE	28480	0160-4210
A7C21	0160-0374	3	4	CAPACITOR-FXD 10UF+-10% 20VDC 1A	56289	1500106X9020B2
A7C22	0160-0374	3		CAPACITOR-FXD 10UF+-10% 20VDC 1A	56289	1500106X9020B2
A7C101	0160-4210	2		CAPACITOR-FXD .022UF +-20% 50VDC POLYE	28480	0160-4210
A7C102	0160-4210	2		CAPACITOR-FXD .022UF +-20% 50VDC POLYE	28480	0160-4210
A7CR1	1901-0050	3		DIODE-SWITCHING 80V 200MA 2NS DO-35	28480	1901-0050
A7CR2	1901-0050	3		DIODE-SWITCHING 80V 200MA 2NS DO-35	28480	1901-0050
A7CR3	1901-0050	3		DIODE-SWITCHING 80V 200MA 2NS DO-35	28480	1901-0050
A7CR4	1901-0050	3		DIODE-SWITCHING 80V 200MA 2NS DO-35	28480	1901-0050
A7CR5	1901-0050	3		DIODE-SWITCHING 80V 200MA 2NS DO-35	28480	1901-0050
A7CR6	1901-0050	3		DIODE-SWITCHING 80V 200MA 2NS DO-35	28480	1901-0050
A7CR7	1901-0050	3		DIODE-SWITCHING 80V 200MA 2NS DO-35	28480	1901-0050
A7CR8	1901-0050	3		DIODE-SWITCHING 80V 200MA 2NS DO-35	28480	1901-0050
A7CR9	1901-0535	9	1	DIODE-SWITCHING 80V 200MA 2NS DO-35	28480	1901-0535
A7MP1	4040-0752	9	1	EXTR=PC BD YEL POLYC .062=BD=THKNS	28480	4040-0752
A7Q1	1853-0215	1		TRANSISTOR NPN SI PD=350MW FT=300MHZ	04713	2N3904
A7Q2	1853-0036	2		TRANSISTOR PNP SI PD=310MW FT=250MHZ	28480	1853-0036
A7Q3	1853-0036	2		TRANSISTOR PNP SI PD=310MW FT=250MHZ	28480	1853-0036
A7Q5	1853-0218	2	2	TRANSISTOR PNP SI TO-18 PD=360MW	28480	1853-0218
A7Q6	1853-0036	2		TRANSISTOR PNP SI PD=310MW FT=250MHZ	28480	1853-0036
A7Q8	1853-0218	2		TRANSISTOR PNP SI TO-18 PD=360MW	28480	1853-0218
A7Q101	1853-0215	1		TRANSISTOR NPN SI PD=350MW FT=300MHZ	04713	2N3904
A7R1	0698-4444	3		RESISTOR 4.87K 1% .125W F TC0+-100	24546	C4=1/B=TO=4871=F
A7R2	0698-3153	9	1	RESISTOR 3.43K 1% .125W F TC0+-100	24546	C4=1/B=TO=3831=F
A7R3	0757-0317	7	1	RESISTOR 1.33K 1% .125W F TC0+-100	24546	C4=1/B=TO=1331=F
A7R4	2100-3274	2	1	RESISTOR-TMR 10K 10% C SIDE-ADJ 1-TRN	28480	2100-3274
A7R5	0757-0442	9		RESISTOR 10K 1% .125W F TC0+-100	24546	C4=1/B=TO=1002=F
A7R6	0757-0407	6		RESISTOR 200 1% .125W F TC0+-100	24546	C4=1/B=TO=201=F
A7R7	0698-4453	4		RESISTOR 402 1% .125W F TC0+-100	24546	C4=1/B=TO=402R=F
A7R8	0698-4453	4		RESISTOR 402 1% .125W F TC0+-100	24546	C4=1/B=TO=402R=F
A7R9	0757-0280	3		RESISTOR 1K 1% .125W F TC0+-100	24546	C4=1/B=TO=1001=F
A7R10	0757-0280	3		RESISTOR 1K 1% .125W F TC0+-100	24546	C4=1/B=TO=1001=F
A7R11	0757-0280	3		RESISTOR 1K 1% .125W F TC0+-100	24546	C4=1/B=TO=1001=F
A7R12	0757-0458	7		RESISTOR 51.1K 1% .125W F TC0+-100	24546	C4=1/B=TO=5112=F
A7R13	0757-0349	5		RESISTOR 22.6K 1% .125W F TC0+-100	24546	C4=1/B=TO=2262=F
A7R14	0757-0465	6		RESISTOR 100K 1% .125W F TC0+-100	24546	C4=1/B=TO=1003=F
A7R15	0757-0280	3		RESISTOR 1K 1% .125W F TC0+-100	24546	C4=1/B=TO=1001=F
A7R16	0698-4435	2		RESISTOR 2.49K 1% .125W F TC0+-100	24546	C4=1/B=TO=2491=F
A7R17	0757-0394	0		RESISTOR 51.1 1% .125W F TC0+-100	24546	C4=1/B=TO=511R=F
A7R18	0757-0283	6		RESISTOR 2K 1% .125W F TC0+-100	24546	C4=1/B=TO=2001=F
A7R19	0757-0411	2		RESISTOR 332 1% .125W F TC0+-100	24546	C4=1/B=TO=332R=F
A7R20	0757-0280	3		RESISTOR 1K 1% .125W F TC0+-100	24546	C4=1/B=TO=1001=F
A7R21	0757-0283	6		RESISTOR 2K 1% .125W F TC0+-100	24546	C4=1/B=TO=2001=F
A7R22	0757-0411	2		RESISTOR 332 1% .125W F TC0+-100	24546	C4=1/B=TO=332R=F
A7R23	0757-0418	9		RESISTOR 619 1% .125W F TC0+-100	24546	C4=1/B=TO=619R=F
A7R24	0757-0433	8		RESISTOR 3.32K 1% .125W F TC0+-100	24546	C4=1/B=TO=3321=F
A7R25	0757-0419	0		RESISTOR 681 1% .125W F TC0+-100	24546	C4=1/B=TO=681R=F
A7R26	0698-3155	1		RESISTOR 4.64K 1% .125W F TC0+-100	24546	C4=1/B=TO=4641=F
A7R27	0757-0419	0		RESISTOR 681 1% .125W F TC0+-100	24546	C4=1/B=TO=681R=F
A7R28	0757-0419	0		RESISTOR 681 1% .125W F TC0+-100	24546	C4=1/B=TO=681R=F
A7R29	0757-0280	3		RESISTOR 1K 1% .125W F TC0+-100	24546	C4=1/B=TO=1001=F
A7R30	0757-0419	0		RESISTOR 681 1% .125W F TC0+-100	24546	C4=1/B=TO=681R=F
A7R31	0698-3433	8	1	RESISTOR 28.7 1% .125W F TC0+-100	03888	PME55=1/B=TO=287R=F
A7R32	0698-3488	3		RESISTOR 442 1% .125W F TC0+-100	24546	C4=1/B=TO=422R=F
A7R33	0757-0401	0		RESISTOR 100 1% .125W F TC0+-100	24546	C4=1/B=TO=101=F
A7R35	0757-0390	6	1	RESISTOR 36.5 1% .125W F TC0+-100	24546	C4=1/B=TO=365R=F
A7R36	0757-0419	0		RESISTOR 681 1% .125W F TC0+-100	24546	C4=1/B=TO=681R=F
A7R37	0757-0280	3		RESISTOR 1K 1% .125W F TC0+-100	24546	C4=1/B=TO=1001=F
A7R38	0757-0280	3		RESISTOR 1K 1% .125W F TC0+-100	24546	C4=1/B=TO=1001=F
A7R39	0698-3488	3		RESISTOR 442 1% .125W F TC0+-100	24546	C4=1/B=TO=422R=F
A7R40	0757-0280	3		RESISTOR 1K 1% .125W F TC0+-100	24546	C4=1/B=TO=1001=F
A7R43	0698-3488	3		RESISTOR 442 1% .125W F TC0+-100	24546	C4=1/B=TO=422R=F

Table 6-3. Replaceable Parts (cont'd)

Reference Designation	HP Part Number	C D	Qty	Description	Mfr Code	Mfr Part Number
A7R44	0698-4392	0	1	RESISTOR 71.5 1% .125W F TC0+100	24546	C4=1/8-T0=71R5=F
A7R45	0698-4469	2	1	RESISTOR 1.15K 1% .125W F TC0+100	24546	C4=1/8-T0=1151=F
A7R46	0698-4420	5	2	RESISTOR 226 1% .125W F TC0+100	24546	C4=1/8-T0=226R=F
A7R50	0698-3488	3		RESISTOR 442 1% .125W F TC0+100	24546	C4=1/8-T0=442R=F
A7R51	0698-3155	1		RESISTOR 4.64K 1% .125W F TC0+100	24546	C4=1/8-T0=4641=F
A7R52	0698-3155	1		RESISTOR 4.64K 1% .125W F TC0+100	24546	C4=1/8-T0=4641=F
A7R53	0698-3155	1		RESISTOR 4.64K 1% .125W F TC0+100	24546	C4=1/8-T0=4641=F
A7R54	0698-3155	1		RESISTOR 4.64K 1% .125W F TC0+100	24546	C4=1/8-T0=4641=F
A7R55	0757-0419	0		RESISTOR 681 1% .125W F TC0+100	24546	C4=1/8-T0=681R=F
A7R56	0757-0400	9	1	RESISTOR 90.9 1% .125W F TC0+100	24546	C4=1/8-T0=90R9=F
A7R57	0698-3150	6		RESISTOR 2.37K 1% .125W F TC0+100	24546	C4=1/8-T0=2371=F
A7R58	0698-3443	0		RESISTOR 287 1% .125W F TC0+100	24546	C4=1/8-T0=287R=F
A7R59	0757-0419	0		RESISTOR 681 1% .125W F TC0+100	24546	C4=1/8-T0=681R=F
A7R60	0757-0280	3		RESISTOR 1K 1% .125W F TC0+100	24546	C4=1/8-T0=1001=F
A7R61	0757-0409	8	1	RESISTOR 274 1% .125W F TC0+100	24546	C4=1/8-T0=274R=F
A7R62	0698-4452	3	1	RESISTOR 374 1% .125W F TC0+100	24546	C4=1/8-T0=374R=F
A7R63	0698-3488	3		RESISTOR 442 1% .125W F TC0+100	24546	C4=1/8-T0=442R=F
A7R101	0757-0349	5		RESISTOR 22.6K 1% .125W F TC0+100	24546	C4=1/8-T0=2262=F
A7R102	0757-0349	5		RESISTOR 22.6K 1% .125W F TC0+100	24546	C4=1/8-T0=2262=F
A7U1	1820-0810	1	1	IC RCVP ECL LINE RCVR TPL 2-INP	04713	MC10116P
A7U2	1820-1400	7	2	IC GATE ECL AND QUAD 2-INP	04713	MC10104P
A7U3	1820-0802	1		IC GATE ECL NOR QUAD 2-INP	04713	MC10102P
A7U4	1820-0817	8	1	IC FF ECL D-M/S DUAL	04713	MC10131P
A7U5	1820-0802	1		IC GATE ECL NOR QUAD 2-INP	04713	MC10102P
A7U6	1820-1400	7		IC GATE ECL AND QUAD 2-INP	04713	MC10104P
A7U7	1820-0804	3	1	IC GATE ECL NOR TPL	04713	MC10106P
A7U8	1820-0802	1		IC GATE ECL NOR QUAD 2-INP	04713	MC10102P
A7U9	1820-0820	3	1	IC FF ECL J-BAR K-BAR COM CLOCK DUAL	04713	MC10135L
A7U10	1820-1193	5	3	IC CNTR TTL LS BIN ASYNCHRO	01295	SN74LS197N
A7U11	1820-1193	5		IC CNTR TTL LS BIN ASYNCHRO	01295	SN74LS197N
A7U12	1820-1193	5		IC CNTR TTL LS BIN ASYNCHRO	01295	SN74LS197N
A7U13	1820-1130	0	1	IC GATE TTL 3 NAND 13-INP	01295	SN748133N
A7U14	1820-1746	4		IC BFP CMOS INV HEX	04713	MC14049UBCP
A7U101	1820-1745	3		IC GATE CMOS NOR QUAD 2-INP	04713	MC14001BCP
A7U102	1820-1963	7		IC FF CMOS D-TYPE POS-EDGE-TRIG DUAL	01928	CD40138AE
A7U103	1820-1745	3		IC GATE CMOS NOR QUAD 2-INP	04713	MC14001BCP
A7U104	1820-1956	8		IC LCH CMOS COM CLOCK QUAD	01928	CD4042BE
A7U105	1820-1956	8		IC LCH CMOS COM CLOCK QUAD	01928	CD4042BE
A7U106	1820-1956	8		IC LCH CMOS COM CLOCK QUAD	01928	CD4042BE
A7U107	1820-1956	8		IC LCH CMOS COM CLOCK QUAD	01928	CD4042BE
A7U108	1820-1956	8		IC LCH CMOS COM CLOCK QUAD	01928	CD4042BE
AB	08165-66508	1	1	BOARD ASSEMBLY, VCO CONTROL	28480	08165-66508
ABC101	0160-3048	2	6	CAPACITOR=FXD 8000PF +/-1% 100VDC MICA	28480	0160-3048
ABC102	0160-3048	2		CAPACITOR=FXD 8000PF +/-1% 100VDC MICA	28480	0160-3048
ABC103	0160-3048	2		CAPACITOR=FXD 8000PF +/-1% 100VDC MICA	28480	0160-3048
ABC104	0160-3048	2		CAPACITOR=FXD 8000PF +/-1% 100VDC MICA	28480	0160-3048
ABC105	0160-3048	2		CAPACITOR=FXD 8000PF +/-1% 100VDC MICA	28480	0160-3048
ABC106	0160-3048	2		CAPACITOR=FXD 8000PF +/-1% 100VDC MICA	28480	0160-3048
ABC107	0160-4209	9		CAPACITOR=FXD .01UF +/-20% 50VDC POLYE	28480	0160-4209
ABC108	0160-0174	9		CAPACITOR=FXD .47UF +/-80-20% 25VDC CER	28480	0160-0174
ABC109	0160-4209	9		CAPACITOR=FXD .01UF +/-20% 50VDC POLYE	28480	0160-4209
ABC110	0160-1704	5		CAPACITOR=FXD .47UF +/-10% 6VDC TA	56289	1500476X900682
ABC111	0160-0375	4		CAPACITOR=FXD 68UF +/-10% 20VDC TA	56289	1500686X902082
ABC112	0160-0375	4		CAPACITOR=FXD 68UF +/-10% 20VDC TA	56289	1500686X902082
ABC113	0160-1704	5		CAPACITOR=FXD .47UF +/-10% 6VDC TA	56289	1500476X900682
ABC201	0160-0128	3		CAPACITOR=FXD 2.2UF +/-20% 50VDC CER	28480	0160-0128
ABC202	0160-4211	3	1	CAPACITOR=FXD .047UF +/-20% 50VDC POLYE	28480	0160-4211
ABC203	0160-4213	5		CAPACITOR=FXD .1UF +/-20% 50VDC POLYE	28480	0160-4213
ABC301	0140-0193	0	4	CAPACITOR=FXD 82PF +/-5% 300VDC MICA	72136	DM15E20J0300WVICR
ABC302	0160-0174	9		CAPACITOR=FXD .47UF +/-80-20% 25VDC CER	28480	0160-0174
ABC402	0160-2150	5		CAPACITOR=FXD 33PF +/-5% 300VDC MICA	28480	0160-2150
ABC501	0140-0196	3		CAPACITOR=FXD 150PF +/-5% 300VDC MICA	72136	DM15F15J0300WVICR
ABC502	0140-0196	3		CAPACITOR=FXD 150PF +/-5% 300VDC MICA	72136	DM15F15J0300WVICR
ABCR201	1901-0040	1		DIODE-SWITCHING 30V 50MA 2NS DO-35	28480	1901-0040
ABCR202	1901-0040	1		DIODE-SWITCHING 30V 50MA 2NS DO-35	28480	1901-0040
ABCR301	1901-0044	5		DIODE-SWITCHING 50V 50MA 6NS	28480	1901-0044
ABCR302	1901-0044	5		DIODE-SWITCHING 50V 50MA 6NS	28480	1901-0044
ABCR303	1901-0044	5		DIODE-SWITCHING 50V 50MA 6NS	28480	1901-0044
ABCR304	1901-0044	5		DIODE-SWITCHING 50V 50MA 6NS	28480	1901-0044
ABCR401	1901-0040	1		DIODE-SWITCHING 30V 50MA 2NS DO-35	28480	1901-0040
ABCR402	1901-0040	1		DIODE-SWITCHING 30V 50MA 2NS DO-35	28480	1901-0040
ABCR403	1901-0044	5		DIODE-SWITCHING 50V 50MA 6NS	28480	1901-0044
ABCR404	1901-0044	5		DIODE-SWITCHING 50V 50MA 6NS	28480	1901-0044

Table 6--3. Replaceable Parts (cont'd)

Reference Designation	HP Part Number	C D	Qty	Description	Mfr Code	Mfr Part Number
ARC405	1901-0044	5		DIODE-SWITCHING 50V 50MA 6NS	28484	1901-0044
ARC406	1901-0044	5		DIODE-SWITCHING 50V 50MA 6NS	28480	1901-0044
ARC501	1901-0040	1		DIODE-SWITCHING 30V 50MA 2NS 00-35	28480	1901-0040
ARC502	1901-0040	1		DIODE-SWITCHING 30V 50MA 2NS 00-35	28480	1901-0040
ARK401	0490-1079	4		RELAY-PEED 1A 500MA 100VDC 5VDC-COIL	28480	0490-1079
ARK402	0490-1079	4		RELAY-PEED 1A 500MA 100VDC 5VDC-COIL	28481	0490-1079
ARMF1	08165-00601	7	1	SHIELD	28480	08165-00601
ARMF2	0040-0751	8	1	EXTR-PC BD ORN POLYC .062-8D-TURNS	28480	0040-0751
ARQ101	1854-0215	1		TRANSISTOR NPN SI PDB350MW FT8300MHZ	04713	2N3904
ARQ102	1854-0215	1		TRANSISTOR NPN SI PDB350MW FT8300MHZ	04713	2N3904
ARQ201	1853-0036	2		TRANSISTOR PNP SI PDB310MW FT8250MHZ	28480	1853-0036
ARQ202	1853-0036	2		TRANSISTOR PNP SI PDB310MW FT8250MHZ	28480	1853-0036
ARQ203	1854-0215	1		TRANSISTOR NPN SI PDB350MW FT8300MHZ	04713	2N3904
ARQ301	1855-0081	1		TRANSISTOR J-FET N-CHAN D-MODE SI	01295	2N5245
ARQ302	1855-0081	1		TRANSISTOR J-FET N-CHAN D-MODE SI	01295	2N5245
ARQ303	1855-0081	1		TRANSISTOR J-FET N-CHAN D-MODE SI	01295	2N5245
ARQ304	1853-0036	2		TRANSISTOR PNP SI PDB310MW FT8250MHZ	28480	1853-0036
ARQ305	1853-0036	2		TRANSISTOR PNP SI PDB310MW FT8250MHZ	28480	1853-0036
ARQ401	1854-0215	1		TRANSISTOR NPN SI PDB350MW FT8300MHZ	04713	2N3904
ARQ402	1854-0215	1		TRANSISTOR NPN SI PDB350MW FT8300MHZ	04713	2N3904
ARQ403	1853-0086	2		TRANSISTOR PNP SI PDB310MW FT840MHZ	27014	2N5087
ARQ404	1854-0215	1		TRANSISTOR NPN SI PDB350MW FT8300MHZ	04713	2N3904
ARQ405	1853-0086	2		TRANSISTOR PNP SI PDB310MW FT840MHZ	27014	2N5087
ARQ406	1854-0215	1		TRANSISTOR NPN SI PDB350MW FT8300MHZ	04713	2N3904
ARQ407	1854-0215	1		TRANSISTOR NPN SI PDB350MW FT8300MHZ	04713	2N3904
ARQ408	1855-0386	9	1	TRANSISTOR J-FET 2N4392 N-CHAN D-MODE	04713	2N4392
ARQ409	1854-0392	5		TRANSISTOR NPN SI PDB310MW FT850MHZ	04713	2N5088
ARQ410	1854-0392	5		TRANSISTOR NPN SI PDB310MW FT850MHZ	04713	2N5088
ARQ411	1854-0583	6		TRANSISTOR NPN SI T0-92 PDB310MW	04713	MP8-A18
ARQ412	1854-0583	6		TRANSISTOR NPN SI T0-92 PDB310MW	04713	MP8-A18
ARQ413	1854-0215	1		TRANSISTOR NPN SI PDB350MW FT8300MHZ	04713	2N3904
ARQ501	1854-0215	1		TRANSISTOR NPN SI PDB350MW FT8300MHZ	04713	2N3904
ARQ502	1853-0036	2		TRANSISTOR PNP SI PDB310MW FT8250MHZ	28480	1853-0036
ARR101	0698-3158	4		RESISTOR 23.7K 1% .125W F TC80+-100	24546	C4=1/8-T0=2372-F
ARR102	0698-3158	4		RESISTOR 23.7K 1% .125W F TC80+-100	24546	C4=1/8-T0=2372-F
ARR103	0698-4482	9	1	RESISTOR 17.4K 1% .125W F TC80+-100	03688	FME55=1/8-T0=1742-F
ARR104	0757-0444	1		RESISTOR 12.1K 1% .125W F TC80+-100	24546	C4=1/8-T0=1212-F
ARR105	0698-3450	9		RESISTOR 42.2K 1% .125W F TC80+-100	24546	C4=1/8-T0=4222-F
ARR106	0698-3450	9		RESISTOR 42.2K 1% .125W F TC80+-100	24546	C4=1/8-T0=4222-F
ARR107	0698-3540	8	2	RESISTOR 15.4K 1% .125W F TC80+-100	24546	C4=1/8-T0=1542-F
ARR108	0757-0444	1		RESISTOR 12.1K 1% .125W F TC80+-100	24546	C4=1/8-T0=1212-F
ARR109	0757-0199	3		RESISTOR 21.5K 1% .125W F TC80+-100	24546	C4=1/8-T0=2152-F
ARR110	0757-0199	3		RESISTOR 21.5K 1% .125W F TC80+-100	24546	C4=1/8-T0=2152-F
ARR111	0757-0199	3		RESISTOR 21.5K 1% .125W F TC80+-100	24546	C4=1/8-T0=2152-F
ARR112	0757-0444	1		RESISTOR 12.1K 1% .125W F TC80+-100	24546	C4=1/8-T0=1212-F
ARR113	0757-0288	1		RESISTOR 9.09K 1% .125W F TC80+-100	19701	MF4C1/8-T0=9091-F
ARR115	0757-0200	7		RESISTOR 5.62K 1% .125W F TC80+-100	24546	C4=1/8-T0=5621-F
ARR116	0757-1094	9		RESISTOR 1.47K 1% .125W F TC80+-100	24546	C4=1/8-T0=1471-F
ARR117	0757-0346	2		RESISTOR 10 1% .125W F TC80+-100	24546	C4=1/8-T0=10R0-F
ARR119	0698-3441	8	1	RESISTOR 215 1% .125W F TC80+-100	24546	C4=1/8-T0=215R-F
ARR120	0757-0441	8	2	RESISTOR 8.25K 1% .125W F TC80+-100	24546	C4=1/8-T0=8251-F
ARR121	0757-0417	8		RESISTOR 562 1% .125W F TC80+-100	24546	C4=1/8-T0=562R-F
ARR201	0757-0442	9		RESISTOR 10K 1% .125W F TC80+-100	24546	C4=1/8-T0=1002-F
ARR202	0698-3155	1		RESISTOR 4.64K 1% .125W F TC80+-100	24546	C4=1/8-T0=4641-F
ARR203	0757-0452	1	3	RESISTOR 27.4K 1% .125W F TC80+-100	24546	C4=1/8-T0=2742-F
ARR204	0698-3245	0	3	RESISTOR 20.5K 1% .125W F TC80+-100	24546	C4=1/8-T0=2052-F
ARR205	0757-0459	8	2	RESISTOR 56.2K 1% .125W F TC80+-100	24546	C4=1/8-T0=5622-F
ARR206	0757-0439	4		RESISTOR 6.81K 1% .125W F TC80+-100	24546	C4=1/8-T0=6811-F
ARR207	0757-0439	4		RESISTOR 6.81K 1% .125W F TC80+-100	24546	C4=1/8-T0=6811-F
ARR208	0757-0444	1		RESISTOR 12.1K 1% .125W F TC80+-100	24546	C4=1/8-T0=1212-F
ARR209	0757-0442	9		RESISTOR 10K 1% .125W F TC80+-100	24546	C4=1/8-T0=1002-F
ARR210	0698-3155	1		RESISTOR 4.64K 1% .125W F TC80+-100	24546	C4=1/8-T0=4641-F
ARR211	0698-0082	7	6	RESISTOR 464 1% .125W F TC80+-100	24546	C4=1/8-T0=4640-F
ARR212	0757-0452	1		RESISTOR 27.4K 1% .125W F TC80+-100	24546	C4=1/8-T0=2742-F
ARR301	0757-1094	9		RESISTOR 1.47K 1% .125W F TC80+-100	24546	C4=1/8-T0=1471-F
ARR302	0698-4483	0	1	RESISTOR 16.7K 1% .125W F TC80+-100	24546	C4=1/8-T0=1672-F
ARR303	0698-3268	7	1	RESISTOR 11.5K 1% .125W F TC80+-100	24546	C4=1/8-T0=1152-F
ARR304	0698-3558	8		RESISTOR 4.02K 1% .125W F TC80+-100	24546	C4=1/8-T0=4021-F
ARR305	0698-6320	8	4	RESISTOR 5K 1% .125W F TC80+-25	03688	FME55=1/8-T0=5001-B
ARR306	0757-0280	3		RESISTOR 1K 1% .125W F TC80+-100	24546	C4=1/8-T0=1001-F
ARR307	0698-6320	8		RESISTOR 5K 1% .125W F TC80+-25	03688	FME55=1/8-T0=5001-B
ARR308	0757-0439	4		RESISTOR 6.81K 1% .125W F TC80+-100	24546	C4=1/8-T0=6811-F
ARR309	0698-3136	8		RESISTOR 17.8K 1% .125W F TC80+-100	24546	C4=1/8-T0=1782-F

Table 6-3. Replaceable Parts (cont'd)

Reference Designation	HP Part Number	C D	Qty	Description	Mfr Code	Mfr Part Number
ARR310	0757-0439	4		RESISTOR 6.81K 1% .125W F TC0+/-100	24546	C4=1/8-T0=6811-F
ARR311	0698-3136	8		RESISTOR 17.8K 1% .125W F TC0+/-100	24546	C4=1/8-T0=1782-F
ARR312	0757-0422	5		RESISTOR 909 1% .125W F TC0+/-100	24546	C4=1/8-T0=909H-F
ARR313	2100-3350	5		RESISTOR-TRMR 200 10% C SIDE=ADJ 1-TRN	28480	2100-3350
ARR314	0698-6320	8		RESISTOR 5K .1% .125W F TC0+/-25	0388A	PME55=1/8-T9=5001-R
ARR315	0698-6320	8		RESISTOR 5K .1% .125W F TC0+/-25	0388A	PME55=1/8-T9=5001-R
ARR317	0757-0280	3		RESISTOR 1K 1% .125W F TC0+/-100	24546	C4=1/8-T0=1001-F
ARR318	2100-3350	5		RESISTOR-TRMR 200 10% C SIDE=ADJ 1-TRN	28480	2100-3350
ARR319	0698-6348	0	2	RESISTOR 3K .1% .125W F TC0+/-25	28480	0698-6348
ARR320	0698-6348	0		RESISTOR 3K .1% .125W F TC0+/-25	28480	0698-6348
ARR401	0757-0439	4		RESISTOR 6.81K 1% .125W F TC0+/-100	24546	C4=1/8-T0=6811-F
ARR402	0757-0439	4		RESISTOR 6.81K 1% .125W F TC0+/-100	24546	C4=1/8-T0=6811-F
ARR403	0698-3245	0		RESISTOR 20.5K 1% .125W F TC0+/-100	24546	C4=1/8-T0=2052-F
ARR404	0698-3156	2		RESISTOR 14.7K 1% .125W F TC0+/-100	24546	C4=1/8-T0=1472-F
ARR405	2100-3207	1		RESISTOR-TRMR 5K 10% C SIDE=ADJ 1-TRN	28480	2100-3207
ARR406	0757-0458	7		RESISTOR 51.1K 1% .125W F TC0+/-100	24546	C4=1/8-T0=5112-F
ARR407	2100-3354	0	2	RESISTOR-TRMR 50K 10% C SIDE=ADJ 1-TRN	28480	2100-3354
ARR408	0698-3245	0		RESISTOR 20.5K 1% .125W F TC0+/-100	24546	C4=1/8-T0=2052-F
ARR409	2100-3352	7		RESISTOR-TRMR 1K 10% C SIDE=ADJ 1-TRN	28480	2100-3352
ARR410	0698-0444	3		RESISTOR 4.87K 1% .125W F TC0+/-100	24546	C4=1/8-T0=4871-F
ARR411	0757-0459	8		RESISTOR 56.2K 1% .125W F TC0+/-100	24546	C4=1/8-T0=5622-F
ARR412	2100-3355	0	1	RESISTOR-TRMR 100K 10% C SIDE=ADJ 1-TRN	28480	2100-3355
ARR413	0757-0199	3		RESISTOR 21.5K 1% .125W F TC0+/-100	24546	C4=1/8-T0=2152-F
ARR414	0698-3178	8		RESISTOR 487 1% .125W F TC0+/-100	24546	C4=1/8-T0=487R-F
ARR415	0757-0444	1		RESISTOR 12.1K 1% .125W F TC0+/-100	24546	C4=1/8-T0=1212-F
ARR416	0757-0444	1		RESISTOR 12.1K 1% .125W F TC0+/-100	24546	C4=1/8-T0=1212-F
ARR417	0757-0417	8		RESISTOR 562 1% .125W F TC0+/-100	24546	C4=1/8-T0=562R-F
ARR418	2100-3207	1		RESISTOR-TRMR 5K 10% C SIDE=ADJ 1-TRN	28480	2100-3207
ARR419	0757-1094	9		RESISTOR 1.47K 1% .125W F TC0+/-100	24546	C4=1/8-T0=1471-F
ARR420	2100-3207	1		RESISTOR-TRMR 5K 10% C SIDE=ADJ 1-TRN	28480	2100-3207
ARR421	0757-0433	8		RESISTOR 3.32K 1% .125W F TC0+/-100	24546	C4=1/8-T0=3321-F
ARR422	0757-0439	4		RESISTOR 6.81K 1% .125W F TC0+/-100	24546	C4=1/8-T0=6811-F
ARR423	0698-3156	2		RESISTOR 14.7K 1% .125W F TC0+/-100	24546	C4=1/8-T0=1472-F
ARR424	0757-0290	5		RESISTOR 6.19K 1% .125W F TC0+/-100	19701	MF4C1/8-T0=6191-F
ARR425	0698-3156	2		RESISTOR 14.7K 1% .125W F TC0+/-100	24546	C4=1/8-T0=1472-F
ARR426	0757-0290	5		RESISTOR 6.19K 1% .125W F TC0+/-100	19701	MF4C1/8-T0=6191-F
ARR427	0698-0083	8		RESISTOR 1.96K 1% .125W F TC0+/-100	24546	C4=1/8-T0=1961-F
ARR428	0698-0442	1		RESISTOR 4.42K 1% .125W F TC0+/-100	24546	C4=1/8-T0=4421-F
ARR429	2100-3358	3	3	RESISTOR-TRMR 1M 20% C SIDE=ADJ 1-TRN	28480	2100-3358
ARR430	0698-5094	1		RESISTOR 5.1M 5% .25W FC TC=900/+1100	01121	CB9155
ARR431	0757-0467	8	3	RESISTOR 121K 1% .125W F TC0+/-100	24546	C4=1/8-T0=1213-F
ARR432	0757-0454	3		RESISTOR 33.2K 1% .125W F TC0+/-100	24546	C4=1/8-T0=3322-F
ARR433	0683-6855	3	1	RESISTOR 6.8M 5% .25W FC TC=900/+1100	01121	CB8855
ARR434	0757-0467	8		RESISTOR 121K 1% .125W F TC0+/-100	24546	C4=1/8-T0=1213-F
ARR435	0757-0454	3		RESISTOR 33.2K 1% .125W F TC0+/-100	24546	C4=1/8-T0=3322-F
ARR436	0683-1065	7		RESISTOR 10M 5% .25W FC TC=900/+1100	01121	CB1065
ARR437	0757-0444	1		RESISTOR 12.1K 1% .125W F TC0+/-100	24546	C4=1/8-T0=1212-F
ARR438	0757-0439	4		RESISTOR 6.81K 1% .125W F TC0+/-100	24546	C4=1/8-T0=6811-F
ARR439	0757-0444	1		RESISTOR 12.1K 1% .125W F TC0+/-100	24546	C4=1/8-T0=1212-F
ARR440	0757-0444	1		RESISTOR 12.1K 1% .125W F TC0+/-100	24546	C4=1/8-T0=1212-F
ARR501	0757-0442	9		RESISTOR 10K 1% .125W F TC0+/-100	24546	C4=1/8-T0=1002-F
ARR502	0757-0442	9		RESISTOR 10K 1% .125W F TC0+/-100	24546	C4=1/8-T0=1002-F
ARR503	0757-0439	4		RESISTOR 6.81K 1% .125W F TC0+/-100	24546	C4=1/8-T0=6811-F
ARR504	0757-0439	4		RESISTOR 6.81K 1% .125W F TC0+/-100	24546	C4=1/8-T0=6811-F
ARR505	0757-0444	1		RESISTOR 12.1K 1% .125W F TC0+/-100	24546	C4=1/8-T0=1212-F
ARR506	0757-0452	1		RESISTOR 27.4K 1% .125W F TC0+/-100	24546	C4=1/8-T0=2742-F
ARR507	0757-0274	5		RESISTOR 1.21K 1% .125W F TC0+/-100	24546	C4=1/8-T0=1213-F
ARU101	1826-0315	3		IC OP AMP GP QUAD 14-DIP-P	27014	LM348N
ARU201	1820-1188	6	2	IC PL LOOP 16-DIP-P	0192B	CD4046AF
ARU202	1826-0043	4		IC OP AMP GP TO-99	0192B	CA307T
ARU301	1826-0043	4		IC OP AMP GP TO-99	0192B	CA307T
ARU302	1826-0188	8		IC CONV 8-B/D/A 16-DIP-C	04713	MC1408L-8
ARU303	1826-0161	7		IC OP AMP GP QUAD 14-DIP-P	04713	MLM324P
ARU401	1826-0059	2		IC OP AMP GP TO-99	01295	LM201AL
ARU402	1826-0415	4	1	IC SWITCH ANLG QUAD 16-DIP-P	18324	SD5000B
ARU501	1826-0111	7		IC OP AMP GP DUAL TO-99	04713	MC1458G
ARU601	1820-1956	8		IC LCH CMOS COM CLOCK QUAD	0192B	CD4042BE
ARU602	1820-1956	8		IC LCH CMOS COM CLOCK QUAD	0192B	CD4042BE
ARU603	1820-1956	8		IC LCH CMOS COM CLOCK QUAD	0192B	CD4042BE
ARU604	1820-1976	2		IC BFR CMOS NON-INV HEX	0192B	CD4050BE
ARU605	1820-1976	2		IC BFR CMOS NON-INV HEX	0192B	CD4050BE
ARU606	1820-1956	6		IC LCH CMOS COM CLOCK QUAD	0192B	CD4042BE
ARU701	1820-1745	3		IC GATE CMOS NOR QUAD 2-INV	04713	MC14001BCP
ARU702	1820-1963	7		IC FF CMOS D-TYPE POS-EDGE-TRIG DUAL	0192B	CD4013BAE
ARU703	1820-1745	3		IC GATE CMOS NOR QUAD 2-INV	04713	MC14001BCP
ARU704	1820-1956	8		IC LCH CMOS COM CLOCK QUAD	0192B	CD4042BE
ARU705	1820-1956	8		IC LCH CMOS COM CLOCK QUAD	0192B	CD4042BE

Table 6-3. Replaceable Parts (cont'd)

Reference Designation	HP Part Number	C D	Qty	Description	Mfr Code	Mfr Part Number
ARU707	1820-1956	A		IC LCM CMOS COM CLOCK QUAD	0192B	CD4042BE
ARU708	1820-1956	B		IC LCM CMOS COM CLOCK QUAD	0192B	CD4042BE
ARU709	1820-1956	B		IC LCM CMOS COM CLOCK QUAD	0192B	CD4042BE
ABVR201	1902-0025	4		DIODE-ZNR 10V 5% DO-7 PDR,4W TC=+.06X	28480	1902-0025
ABVR202	1902-0025	4		DIODE-ZNR 10V 5% DO-7 PDR,4W TC=+.06X	28480	1902-0025
ABVR301	1902-3105	7	1	DIODE-ZNR 5.62V 2% DO-7 PDR,4W TC=+.016X	28480	1902-3105
ABVR302	1902-0041	4		DIODE-ZNR 5.11V 5% DO-7 PDR,4W TC=+.009X	28480	1902-0041
ABVR303	1902-0041	4		DIODE-ZNR 5.11V 5% DO-7 PDR,4W TC=+.009X	28480	1902-0041
A9	08165-66509	2	1	BOARD ASSEMBLY, REFERENCE LOOP	28480	08165-66509
A9C201	0160-4209	9		CAPACITOR-FXD .01UF +-20% 50VDC POLYE	28480	0160-4209
A9C202	0160-0374	3		CAPACITOR-FXD 10UF+-10% 20VDC TA	56289	150D106X9020B2
A9C203	0160-0174	9		CAPACITOR-FXD .47UF +80-20% 25VDC CER	28480	0160-0174
A9C204	0160-4209	9		CAPACITOR-FXD .01UF +-20% 50VDC POLYE	28480	0160-4209
A9C205	0160-0196	3		CAPACITOR-FXD 150PF +-5% 300VDC MICA	72136	DM15P151J0300V1CR
A9C302	0160-3220	2	1	CAPACITOR-FXD 6800PF +-5% 250VDC	28480	0160-3220
A9C303	0160-0197	8		CAPACITOR-FXD 2.2UF+-10% 20VDC TA	56289	150D225X9020A2
A9C304	0160-0197	8		CAPACITOR-FXD 2.2UF+-10% 20VDC TA	56289	150D225X9020A2
A9C401	0160-0116	1		CAPACITOR-FXD 6.8UF+-10% 35VDC TA	56289	150D685X9035B2
A9C402	0160-0174	9		CAPACITOR-FXD .47UF +80-20% 25VDC CER	28480	0160-0174
A9C403	0160-4212	4		CAPACITOR-FXD .068UF +-20% 50VDC POLYE	28480	0160-4212
A9C404	0160-0174	9		CAPACITOR-FXD .47UF +80-20% 25VDC CER	28480	0160-0174
A9C405	0160-1704	5		CAPACITOR-FXD .47UF+-10% 6VDC TA	56289	150D476X9006B2
A9C501	0160-0174	9		CAPACITOR-FXD .47UF +80-20% 25VDC CER	28480	0160-0174
A9C502	0160-0174	9		CAPACITOR-FXD .47UF +80-20% 25VDC CER	28480	0160-0174
A9C503	0160-0576	5		CAPACITOR-FXD .1UF +-20% 50VDC CER	28480	0160-0576
A9C602	0121-0165	6	1	CAPACITOR-V TRMP-CER 7-25PF 350V PC-MTG	52763	304324 7/25PF N300
A9C603	0160-0174	9		CAPACITOR-FXD .47UF +80-20% 25VDC CER	28480	0160-0174
A9C604	0160-4209	9		CAPACITOR-FXD .01UF +-20% 50VDC POLYE	28480	0160-4209
A9C701	0160-2055	9		CAPACITOR-FXD .01UF +80-20% 100VDC CER	28480	0160-2055
A9C702	0160-2055	9		CAPACITOR-FXD .01UF +80-20% 100VDC CER	28480	0160-2055
A9C703	0160-4210	2		CAPACITOR-FXD .022UF +-20% 50VDC POLYE	28480	0160-4210
A9C704	0160-0190	7	1	CAPACITOR-FXD 39PF +-5% 300VDC MICA	72136	DM15E390J0300V1CR
A9C705	0160-0174	9		CAPACITOR-FXD .47UF +80-20% 25VDC CER	28480	0160-0174
A9C706	0160-4213	5		CAPACITOR-FXD .1UF +-20% 50VDC POLYE	28480	0160-4213
A9CR201	1901-0040	1		DIODE-SWITCHING 30V 50MA 2NS DO-35	28480	1901-0040
A9CR202	1901-0040	1		DIODE-SWITCHING 30V 50MA 2NS DO-35	28480	1901-0040
A9CR301	1901-0040	1		DIODE-SWITCHING 30V 50MA 2NS DO-35	28480	1901-0040
A9CR302	1901-0040	1		DIODE-SWITCHING 30V 50MA 2NS DO-35	28480	1901-0040
A9CR303	1901-0040	1		DIODE-SWITCHING 30V 50MA 2NS DO-35	28480	1901-0040
A9CR304	1901-0040	1		DIODE-SWITCHING 30V 50MA 2NS DO-35	28480	1901-0040
A9CR501	1901-0040	1		DIODE-SWITCHING 30V 50MA 2NS DO-35	28480	1901-0040
A9CR502	1901-0040	1		DIODE-SWITCHING 30V 50MA 2NS DO-35	28480	1901-0040
A9CR503	1901-0040	1		DIODE-SWITCHING 30V 50MA 2NS DO-35	28480	1901-0040
A9CR504	1901-0040	1		DIODE-SWITCHING 30V 50MA 2NS DO-35	28480	1901-0040
A9CR505	1901-0040	1		DIODE-SWITCHING 30V 50MA 2NS DO-35	28480	1901-0040
A9CR506	1901-0040	1		DIODE-SWITCHING 30V 50MA 2NS DO-35	28480	1901-0040
A9CR507	1901-0040	1		DIODE-SWITCHING 30V 50MA 2NS DO-35	28480	1901-0040
A9CR508	1901-0040	1		DIODE-SWITCHING 30V 50MA 2NS DO-35	28480	1901-0040
A9CR509	1901-0040	1		DIODE-SWITCHING 30V 50MA 2NS DO-35	28480	1901-0040
A9CR510	1901-0040	1		DIODE-SWITCHING 30V 50MA 2NS DO-35	28480	1901-0040
A9CR511	1901-0040	1		DIODE-SWITCHING 30V 50MA 2NS DO-35	28480	1901-0040
A9CR512	1901-0040	1		DIODE-SWITCHING 30V 50MA 2NS DO-35	28480	1901-0040
A9CR601	1901-0040	1		DIODE-SWITCHING 30V 50MA 2NS DO-35	28480	1901-0040
A9CR701	1901-0040	1		DIODE-SWITCHING 30V 50MA 2NS DO-35	28480	1901-0040
A9CR702	1901-0040	1		DIODE-SWITCHING 30V 50MA 2NS DO-35	28480	1901-0040
A9CR703	1901-0040	1		DIODE-SWITCHING 30V 50MA 2NS DO-35	28480	1901-0040
A9CR704	1901-0040	1		DIODE-SWITCHING 30V 50MA 2NS DO-35	28480	1901-0040
A9J1	1251-4047	7	1	CONNECTOR 3-PIN M POST TYPE	28480	1251-4047
A9Q201	1854-0215	1		TRANSISTOR NPN SI PD=350MW FT=300MHZ	04713	2N3904
A9Q202	1854-0215	1		TRANSISTOR NPN SI PD=350MW FT=300MHZ	04713	2N3904
A9Q301	1853-0400	4		TRANSISTOR PNP SI DARL TC=92 PD=500MW	28480	1853-0400
A9Q302	1853-0086	2		TRANSISTOR PNP SI PD=310MW FT=40MHZ	27014	2N5087
A9Q303	1854-0392	5		TRANSISTOR NPN SI PD=310MW FT=50MHZ	04713	2N5088
A9Q304	1853-0036	2		TRANSISTOR PNP SI PD=310MW FT=250MHZ	28480	1853-0036
A9Q305	1854-0215	1		TRANSISTOR NPN SI PD=350MW FT=300MHZ	04713	2N3904
A9Q306	1853-0036	2		TRANSISTOR PNP SI PD=310MW FT=250MHZ	28480	1853-0036
A9Q501	1854-0215	1		TRANSISTOR NPN SI PD=350MW FT=300MHZ	04713	2N3904
A9Q502	1854-0215	1		TRANSISTOR NPN SI PD=350MW FT=300MHZ	04713	2N3904
A9Q503	1853-0036	2		TRANSISTOR PNP SI PD=310MW FT=250MHZ	28480	1853-0036
A9Q504	1853-0036	2		TRANSISTOR PNP SI PD=310MW FT=250MHZ	28480	1853-0036
A9Q601	1853-0036	2		TRANSISTOR PNP SI PD=310MW FT=250MHZ	28480	1853-0036
A9Q701	1855-0062	8	1	TRANSISTOR J-FET N-CHAN D-MODE SI	28480	1855-0062

Table 6-3. Replaceable Parts (cont'd)

Reference Designation	HP Part Number	C D	Qty	Description	Mfr Code	Mfr Part Number
A9R101	0698-3155	1		RESISTOR 4.64K 1% .125W F TC0+-100	24546	C4-1/8-T0-4641-F
A9R201	0698-4433	0		RESISTOR 2.26K 1% .125W F TC0+-100	24546	C4-1/8-T0-2261-F
A9R202	0698-4433	0		RESISTOR 2.26K 1% .125W F TC0+-100	24546	C4-1/8-T0-2261-F
A9R203	0757-0444	1		RESISTOR 12.1K 1% .125W F TC0+-100	24546	C4-1/8-T0-1212-F
A9R204	0757-0444	1		RESISTOR 12.1K 1% .125W F TC0+-100	24546	C4-1/8-T0-1212-F
A9R205	0757-0274	5		RESISTOR 1.21K 1% .125W F TC0+-100	24546	C4-1/8-T0-1213-F
A9R206	0757-0444	1		RESISTOR 12.1K 1% .125W F TC0+-100	24546	C4-1/8-T0-1212-F
A9R207	0757-0439	4		RESISTOR 6.81K 1% .125W F TC0+-100	24546	C4-1/8-T0-6811-F
A9R208	0698-4433	0		RESISTOR 2.26K 1% .125W F TC0+-100	24546	C4-1/8-T0-2261-F
A9R209	0757-0444	1		RESISTOR 12.1K 1% .125W F TC0+-100	24546	C4-1/8-T0-1212-F
A9R210	0698-3260	9		RESISTOR 464K 1% .125W F TC0+-100	26480	0698-3260
A9R211	0757-0442	9		RESISTOR 10K 1% .125W F TC0+-100	24546	C4-1/8-T0-1002-F
A9R212	0757-0444	1		RESISTOR 12.1K 1% .125W F TC0+-100	24546	C4-1/8-T0-1212-F
A9R213	0698-3558	0		RESISTOR 4.02K 1% .125W F TC0+-100	24546	C4-1/8-T0-4021-F
A9R214	0698-4433	A		RESISTOR 2.26K 1% .125W F TC0+-100	24546	C4-1/8-T0-2261-F
A9R301	0698-6942	0	3	RESISTOR 25K .1% .125W F TC0+-50	26480	0698-6942
A9R302	0698-6942	0		RESISTOR 25K .1% .125W F TC0+-50	26480	0698-6942
A9R303	0698-6608	0	5	RESISTOR 23.5K .1% .125W F TC0+-25	26480	0698-6608
A9R304	0698-6942	0	3	RESISTOR 25K .1% .125W F TC0+-50	26480	0698-6942
A9R306	0757-0280	0	3	RESISTOR 1K 1% .125W F TC0+-100	24546	C4-1/8-T0-1001-F
A9R307	0757-0280	3		RESISTOR 1K 1% .125W F TC0+-100	24546	C4-1/8-T0-1001-F
A9R308	0698-3558	8		RESISTOR 4.02K 1% .125W F TC0+-100	24546	C4-1/8-T0-4021-F
A9R309	0698-3558	8		RESISTOR 4.02K 1% .125W F TC0+-100	24546	C4-1/8-T0-4021-F
A9R310	2100-3207	1		RESISTOR-TMR 5K 10% C SIDE-ADJ 1-TRN	26480	2100-3207
A9R311	0757-0444	1		RESISTOR 12.1K 1% .125W F TC0+-100	24546	C4-1/8-T0-1212-F
A9R312	0757-0274	5		RESISTOR 1.21K 1% .125W F TC0+-100	24546	C4-1/8-T0-1213-F
A9R313	2100-3353	8	1	RESISTOR-TMR 20K 10% C SIDE-ADJ 1-TRN	32997	3366xY46-203
A9R314	0757-0407	6		RESISTOR 200 1% .125W F TC0+-100	24546	C4-1/8-T0-201-F
A9R315	0698-3136	8		RESISTOR 17.8K 1% .125W F TC0+-100	24546	C4-1/8-T0-1782-F
A9R316	0698-3155	1		RESISTOR 4.64K 1% .125W F TC0+-100	24546	C4-1/8-T0-4641-F
A9R401	0698-3156	2		RESISTOR 14.7K 1% .125W F TC0+-100	24546	C4-1/8-T0-1472-F
A9R402	0757-0394	0		RESISTOR 51.1 1% .125W F TC0+-100	24546	C4-1/8-T0-51R1-F
A9R403	0757-0394	0		RESISTOR 51.1 1% .125W F TC0+-100	24546	C4-1/8-T0-51R1-F
A9R404	0757-0442	9		RESISTOR 10K 1% .125W F TC0+-100	24546	C4-1/8-T0-1002-F
A9R405	0757-0442	9		RESISTOR 10K 1% .125W F TC0+-100	24546	C4-1/8-T0-1002-F
A9R406	2100-3103	6		RESISTOR-TMR 10K 10% C SIDE-ADJ 17-TRN	02111	43P103
A9R407	0698-0082	7		RESISTOR 464 1% .125W F TC0+-100	24546	C4-1/8-T0-4640-F
A9R408	0757-0394	0		RESISTOR 51.1 1% .125W F TC0+-100	24546	C4-1/8-T0-51R1-F
A9R409	0757-0280	3		RESISTOR 1K 1% .125W F TC0+-100	24546	C4-1/8-T0-1001-F
A9R410	0757-0280	3		RESISTOR 1K 1% .125W F TC0+-100	24546	C4-1/8-T0-1001-F
A9R411	0757-0439	4		RESISTOR 6.81K 1% .125W F TC0+-100	24546	C4-1/8-T0-6811-F
A9R412	0698-3154	0		RESISTOR 4.22K 1% .125W F TC0+-100	24546	C4-1/8-T0-4221-F
A9R413	0698-3154	0		RESISTOR 4.22K 1% .125W F TC0+-100	24546	C4-1/8-T0-4221-F
A9R414	0757-0280	3		RESISTOR 1K 1% .125W F TC0+-100	24546	C4-1/8-T0-1001-F
A9R501	0757-0283	6		RESISTOR 2K 1% .125W F TC0+-100	24546	C4-1/8-T0-2001-F
A9R502	0698-3437	2		RESISTOR 133 1% .125W F TC0+-100	24546	C4-1/8-T0-133R-F
A9R503	0757-0280	3		RESISTOR 1K 1% .125W F TC0+-100	24546	C4-1/8-T0-1001-F
A9R504	0698-3437	2		RESISTOR 133 1% .125W F TC0+-100	24546	C4-1/8-T0-133R-F
A9R505	0757-0399	5	2	RESISTOR 82.5 1% .125W F TC0+-100	24546	C4-1/8-T0-82R5-F
A9R506	0698-0082	7		RESISTOR 464 1% .125W F TC0+-100	24546	C4-1/8-T0-4640-F
A9R507	0757-0399	5		RESISTOR 82.5 1% .125W F TC0+-100	24546	C4-1/8-T0-82R5-F
A9R508	0698-4037	0		RESISTOR 46.4 1% .125W F TC0+-100	24546	C4-1/8-T0-46R4-F
A9R509	0757-0411	2		RESISTOR 332 1% .125W F TC0+-100	24546	C4-1/8-T0-332R-F
A9R510	0698-4037	0		RESISTOR 46.4 1% .125W F TC0+-100	24546	C4-1/8-T0-46R4-F
A9R511	0757-0388	2		RESISTOR 30.1 1% .125W F TC0+-100	24546	C4-1/8-T0-30R1-F
A9R512	0757-0403	2	1	RESISTOR 121 1% .125W F TC0+-100	24546	C4-1/8-T0-121R-F
A9R513	0757-0388	2		RESISTOR 30.1 1% .125W F TC0+-100	24546	C4-1/8-T0-30R1-F
A9R514	0698-3435	0	3	RESISTOR 38.3 1% .125W F TC0+-100	24546	C4-1/8-T0-38R3-F
A9R515	0698-3435	0		RESISTOR 38.3 1% .125W F TC0+-100	24546	C4-1/8-T0-38R3-F
A9R516	0757-0444	1		RESISTOR 12.1K 1% .125W F TC0+-100	24546	C4-1/8-T0-1212-F
A9R517	0698-3136	8		RESISTOR 17.8K 1% .125W F TC0+-100	24546	C4-1/8-T0-1782-F
A9R518	0757-0433	8		RESISTOR 3.32K 1% .125W F TC0+-100	24546	C4-1/8-T0-3321-F
A9R519	0757-1094	9		RESISTOR 1.47K 1% .125W F TC0+-100	24546	C4-1/8-T0-1471-F
A9R520	0757-1094	9		RESISTOR 1.47K 1% .125W F TC0+-100	24546	C4-1/8-T0-1471-F
A9R521	0757-0433	8		RESISTOR 3.32K 1% .125W F TC0+-100	24546	C4-1/8-T0-3321-F
A9R522	0757-0444	1		RESISTOR 12.1K 1% .125W F TC0+-100	24546	C4-1/8-T0-1212-F
A9R523	0698-3136	8		RESISTOR 17.8K 1% .125W F TC0+-100	24546	C4-1/8-T0-1782-F
A9R601	0698-0082	7		RESISTOR 464 1% .125W F TC0+-100	24546	C4-1/8-T0-4640-F
A9R602	0757-0424	7		RESISTOR 1.1K 1% .125W F TC0+-100	24546	C4-1/8-T0-1101-F
A9R603	0757-1094	7		RESISTOR 1.47K 1% .125W F TC0+-100	24546	C4-1/8-T0-1471-F
A9R604	0757-1094	9		RESISTOR 1.47K 1% .125W F TC0+-100	24546	C4-1/8-T0-1471-F
A9R605	0757-1094	9		RESISTOR 1.47K 1% .125W F TC0+-100	24546	C4-1/8-T0-1471-F
A9R606	0757-1094	9		RESISTOR 1.47K 1% .125W F TC0+-100	24546	C4-1/8-T0-1471-F
A9R607	0698-3435	0		RESISTOR 38.3 1% .125W F TC0+-100	24546	C4-1/8-T0-38R3-F
A9R608	0698-4420	5		RESISTOR 226 1% .125W F TC0+-100	24546	C4-1/8-T0-226R-F

Table 6-3. Replaceable Parts (cont'd)

Reference Designation	HP Part Number	C D	Qty	Description	Mfr Code	Mfr Part Number
A9R609	0757-0422	5		RESISTOR 909 1% .125W F TC0+100	24546	C4=1/B=TO=909F-F
A9R610	0757-1094	9		RESISTOR 1.47K 1% .125W F TC0+100	24546	C4=1/B=TO=1471-F
A9R611	0757-0419	0		RESISTOR 681 1% .125W F TC0+100	24546	C4=1/B=TO=681R-F
A9R612	0757-0274	5		RESISTOR 1.21K 1% .125W F TC0+100	24546	C4=1/B=TO=1213-F
A9R701	0757-0454	3		RESISTOR 33.2K 1% .125W F TC0+100	24546	C4=1/B=TO=3322-F
A9R702	0698-3136	6		RESISTOR 17.6K 1% .125W F TC0+100	24546	C4=1/B=TO=1762-F
A9R703	0757-0454	3		RESISTOR 33.2K 1% .125W F TC0+100	24546	C4=1/B=TO=3322-F
A9R704	0698-3136	6		RESISTOR 17.6K 1% .125W F TC0+100	24546	C4=1/B=TO=1762-F
A9R705	0757-0467	8		RESISTOR 121K 1% .125W F TC0+100	24546	C4=1/B=TO=1213-F
A9R706	0698-3136	6		RESISTOR 17.6K 1% .125W F TC0+100	24546	C4=1/B=TO=1762-F
A9R707	0698-0085	0		RESISTOR 2.61K 1% .125W F TC0+100	24546	C4=1/B=TO=2611-F
A9R708	0757-0280	3		RESISTOR 1K 1% .125W F TC0+100	24546	C4=1/B=TO=1001-F
A9R709	0757-0274	5		RESISTOR 1.21K 1% .125W F TC0+100	24546	C4=1/B=TO=1213-F
A9U101	1820-1963	7		IC FF CMOS D-TYPE POS-EDGE-TRIG DUAL	0192B	CD40138AE
A9U102	1820-1963	7		IC FF CMOS D-TYPE POS-EDGE-TRIG DUAL	0192B	CD40138AE
A9U103	1820-1747	5	2	IC GATE CMOS NAND GUAD 2-INP	04713	MC14011BCF
A9U104	1820-1745	3		IC GATE CMOS NOR GUAD 2-INP	04713	MC14001BCF
A9U105	1820-1956	8		IC LCM CMOS COM CLOCK GUAD	0192B	CD4042BE
A9U106	1820-1963	7		IC FF CMOS D-TYPE POS-EDGE-TRIG DUAL	0192B	CD40138AE
A9U107	1820-1956	8		IC LCM CMOS COM CLOCK GUAD	0192B	CD4042BE
A9U108	1820-1956	8		IC LCM CMOS COM CLOCK GUAD	0192B	CD4042BE
A9U109	1820-1956	8		IC LCM CMOS COM CLOCK GUAD	0192B	CD4042BE
A9U110	1820-1956	8		IC LCM CMOS COM CLOCK GUAD	0192B	CD4042BE
A9U111	1820-1747	5		IC GATE CMOS NAND GUAD 2-INP	04713	MC14011BCF
A9U112	1820-1442	7	10	IC CNTR TTL LS DECD ASYNCHRO	01295	SN74LS290N
A9U113	1820-1442	7		IC CNTR TTL LS DECD ASYNCHRO	01295	SN74LS290N
A9U114	1820-1198	0	1	IC GATE TTL LS NAND GUAD 2-INP	01295	SN74LS03N
A9U115	1820-1442	7		IC CNTR TTL LS DECD ASYNCHRO	01295	SN74LS290N
A9U201	1820-1279	6	5	IC CNTR TTL LS DECD UP/DOWN SYNCHRO	01295	SN74LS190N
A9U202	1820-1279	6		IC CNTR TTL LS DECD UP/DOWN SYNCHRO	01295	SN74LS190N
A9U203	1820-1112	8	1	IC FF TTL LS D-TYPE POS-EDGE-TRIG	01295	SN74LS74N
A9U204	1820-1202	7	2	IC GATE TTL LS NAND TPL 3-INP	01295	SN74LS10N
A9U205	1820-1197	9		IC GATE TTL LS NAND GUAD 2-INP	01295	SN74LS00N
A9U206	1820-1963	7		IC FF CMOS D-TYPE POS-EDGE-TRIG DUAL	0192B	CD40138AE
A9U207	1826-0043	4		IC OP AMP GP TO-99	0192B	CA307T
A9U208	1820-1188	8		IC PL LOOP 16-DIP-P	0192B	CD4046AF
A9U209	1820-1442	7		IC CNTR TTL LS DECD ASYNCHRO	01295	SN74LS290N
A9U210	1820-1442	7		IC CNTR TTL LS DECD ASYNCHRO	01295	SN74LS290N
A9U301	1826-0111	7		IC OP AMP GP DUAL TO-99	04713	MC1458G
A9U302	1826-0043	4		IC OP AMP GP TO-99	0192B	CA307T
A9U303	1826-0043	4		IC OP AMP GP TO-99	0192B	EA307T
A9U304	1826-0111	7		IC OP AMP GP DUAL TO-99	04713	MC1458G
A9U401	1820-0427	6	1	IC MODULATOR TO-100	04713	MC1496G
A9U601	1820-0802	1		IC GATE ECL NOR GUAD 2-INP	04713	MC10102P
A9U602	1820-1442	7		IC CNTR TTL LS DECD ASYNCHRO	01295	SN74LS290N
A9U603	1820-1122	0	2	IC CNTR CMOS BCD SYNCHRO DUAL	04713	MC14516BCF
A9U701	1820-1279	6		IC CNTR TTL LS DECD UP/DOWN SYNCHRO	01295	SN74LS190N
A9U702	1820-1279	6		IC CNTR TTL LS DECD UP/DOWN SYNCHRO	01295	SN74LS190N
A9U703	1820-1279	6		IC CNTR TTL LS DECD UP/DOWN SYNCHRO	01295	SN74LS190N
A9U704	1820-0629	0	2	IC FF TTL S J-K NEG-EDGE-TRIG	01295	SN74LS112N
A9U705	1820-1197	9		IC GATE TTL LS NAND GUAD 2-INP	01295	SN74LS00N
A9U706	1820-1202	7		IC GATE TTL LS NAND TPL 3-INP	01295	SN74LS10N
A9U707	1820-1963	7		IC FF CMOS D-TYPE POS-EDGE-TRIG DUAL	0192B	CD40138AE
A9U708	1820-0567	5	1	IC MV TTL DUAL	04713	MC4024P
A9U709	1820-1442	7		IC CNTR TTL LS DECD ASYNCHRO	01295	SN74LS290N
A9U710	1820-1442	7		IC CNTR TTL LS DECD ASYNCHRO	01295	SN74LS290N
A9U711	1820-1122	0		IC CNTR CMOS BCD SYNCHRO DUAL	04713	MC14516BCF
A9VR201	1902-0048	1		DIODE-ZNR 6.81V 5% DO-7 PDS.4W TC+0.43%	28480	1902-0048
A9VR301	1902-3036	3	2	DIODE-ZNR 3.16V 5% DO-7 PDS.4W TC+0.64%	28480	1902-3036
A9VR302	1902-3036	3		DIODE-ZNR 3.16V 5% DO-7 PDS.4W TC+0.64%	28480	1902-3036
A9VR601	1902-3139	7	1	DIODE-ZNR 6.25V 5% DO-7 PDS.4W TC+0.53%	28480	1902-3139
A9VR501	1902-0025	4		DIODE-ZNR 10V 5% DO-7 PDS.4W TC+0.06%	28480	1902-0025
A9VR502	1902-0025	4		DIODE-ZNR 10V 5% DO-7 PDS.4W TC+0.06%	28480	1902-0025
A9VR701	1902-3182	0		DIODE-ZNR 12.1V 5% DO-7 PDS.4W TC+0.64%	28480	1902-3182
A9Y601	0410-0423	2	1	CRYSTAL=QUARTZ (MISC ITEM)	28480	0410-0423
A10	08165-66510	5	1	BOARD ASSEMBLY, LOW FREQUENCY G	28480	08165-66510
A10C1	0160-2257	3		CAPACITOR=FXD 10PF +5% 50VDC CER 0+60	28480	0160-2257
A10C2	0160-0116	1		CAPACITOR=FXD 6.8UF+10% 35VDC TA	56289	1500685X035B2
A10C3	0160-4209	9		CAPACITOR=FXD .01UF +20% 50VDC POLYE	28480	0160-4209
A10C4	0160-4209	9		CAPACITOR=FXD .01UF +20% 50VDC POLYE	28480	0160-4209
A10C5	0160-4209	9		CAPACITOR=FXD .01UF +20% 50VDC POLYE	28480	0160-4209

Table 6--3. Replaceable Parts (cont'd)

Reference Designation	HP Part Number	C D	Qty	Description	Mfr Code	Mfr Part Number
A10C6	0160-2208	4	1	CAPACITOR-FXD 330PF +-5% 300VDC MICA	28480	0160-2208
A10C7	0160-4209	9		CAPACITOR-FXD .01UF +-20% 50VDC POLYE	28480	0160-4209
A10C201	0180-0116	1		CAPACITOR-FXD 6.8UF+-10% 35VDC TA	56289	150D685X9035B2
A10C202	0180-0197	8		CAPACITOR-FXD 2.2UF+-10% 20VDC TA	56289	150D225X9020A2
A10C203	0180-0374	3		CAPACITOR-FXD 10UF+-10% 20VDC TA	56289	150D106X9020B2
A10C204	0160-0174	9		CAPACITOR-FXD .47UF +80-20% 25VDC CER	28480	0160-0174
A10C205	0140-0193	0		CAPACITOR-FXD 82PF +-5% 300VDC MICA	72136	DM15E20J0300WV1CR
A10C206	0140-0192	9		CAPACITOR-FXD 68PF +-5% 300VDC MICA	72136	DM15E60J0300WV1CR
A10C207	0160-2055	9		CAPACITOR-FXD .01UF +80-20% 100VDC CER	28480	0160-2055
A10C208	0160-4210	2		CAPACITOR-FXD .022UF +-20% 50VDC POLYE	28480	0160-4210
A10C209	0160-2055	9		CAPACITOR-FXD .01UF +80-20% 100VDC CER	28480	0160-2055
A10CR201	1901-0040	1		DIODE-SWITCHING 30V 50MA 2NS DO-35	28480	1901-0040
A10CR202	1901-0040	1		DIODE-SWITCHING 30V 50MA 2NS DO-35	28480	1901-0040
A10MP1	4040-0749	4	1	EXTR-PC BD BRN POLYC .062-RO-TMKNS	28480	4040-0749
	5000-8991	1	1	TERMINAL, TEST POINT	28480	5000-8991
A10Q201	1854-0583	6		TRANSISTOR NPN 8I TO-92 PD=310MW	04713	MP8-A18
A10Q202	1854-0583	6		TRANSISTOR NPN 8I TO-92 PD=310MW	04713	MP8-A18
A10Q203	1854-0583	6		TRANSISTOR NPN 8I TO-92 PD=310MW	04713	MP8-A18
A10Q204	1853-0221	9		TRANSISTOR PNP 2N2907A 8I TO-18 PD=400MW	04713	2N2907A
A10Q205	1853-0036	2		TRANSISTOR PNP 8I PD=310MW FT=250MHZ	28480	1853-0036
A10Q206	1854-0215	1		TRANSISTOR NPN 8I PD=350MW FT=300MHZ	04713	2N3904
A10R1	0698-4471	6		RESISTOR 7.15K 1% .125W F TC=0+-100	24546	C4=1/8-T0-7151-F
A10R201	0698-3540	8		RESISTOR 15.4K 1% .125W F TC=0+-100	24546	C4=1/8-T0-1542-F
A10R202	0698-4442	1		RESISTOR 4.42K 1% .125W F TC=0+-100	24546	C4=1/8-T0-4421-F
A10R203	0698-3558	8		RESISTOR 4.02K 1% .125W F TC=0+-100	24546	C4=1/8-T0-4021-F
A10R204	0698-4453	4		RESISTOR 402 1% .125W F TC=0+-100	24546	C4=1/8-T0-402R-F
A10R205	0757-0280	3		RESISTOR 1K 1% .125W F TC=0+-100	24546	C4=1/8-T0-1001-F
A10R206	2100-3154	7		RESISTOR-TRMR 1K 10% C 8IDE-ADJ 17-TRN	02111	43P102
A10R207	0698-3558	8		RESISTOR 4.02K 1% .125W F TC=0+-100	24546	C4=1/8-T0-4021-F
A10R208	0757-0428	1		RESISTOR 1.62K 1% .125W F TC=0+-100	24546	C4=1/8-T0-1621-F
A10R209	0698-3484	9	1	RESISTOR 6.65K 1% .125W F TC=0+-100	24546	C4=1/8-T0-6651-F
A10R210	0757-0441	8		RESISTOR 8.25K 1% .125W F TC=0+-100	24546	C4=1/8-T0-8251-F
A10R211	0757-0401	0		RESISTOR 100 1% .125W F TC=0+-100	24546	C4=1/8-T0-101-F
A10R212	2100-3154	7		RESISTOR-TRMR 1K 10% C 8IDE-ADJ 17-TRN	02111	43P102
A10R213	0698-3558	8		RESISTOR 4.02K 1% .125W F TC=0+-100	24546	C4=1/8-T0-4021-F
A10R214	0757-0280	3		RESISTOR 1K 1% .125W F TC=0+-100	24546	C4=1/8-T0-1001-F
A10R215	0698-4425	0		RESISTOR 1.54K 1% .125W F TC=0+-100	24546	C4=1/8-T0-1541-F
A10R216	0698-4477	2	1	RESISTOR 10.5K 1% .125W F TC=0+-100	24546	C4=1/8-T0-1052-F
A10R217	0698-3156	2		RESISTOR 14.7K 1% .125W F TC=0+-100	24546	C4=1/8-T0-1472-F
A10R218	0757-0458	7		RESISTOR 51.1K 1% .125W F TC=0+-100	24546	C4=1/8-T0-5112-F
A10R219	0698-4435	2		RESISTOR 2.49K 1% .125W F TC=0+-100	24546	C4=1/8-T0-2491-F
A10R220	0698-3451	0		RESISTOR 133K 1% .125W F TC=0+-100	24546	C4=1/8-T0-1333-F
A10R221	0757-0465	6		RESISTOR 100K 1% .125W F TC=0+-100	24546	C4=1/8-T0-1003-F
A10R222	0698-3451	0		RESISTOR 133K 1% .125W F TC=0+-100	24546	C4=1/8-T0-1333-F
A10R223	0698-3451	0		RESISTOR 133K 1% .125W F TC=0+-100	24546	C4=1/8-T0-1333-F
A10R224	0698-4207	6	1	RESISTOR 44.2K 1% .125W F TC=0+-100	24546	C4=1/8-T0-4422-F
A10R225	0757-0442	9		RESISTOR 10K 1% .125W F TC=0+-100	24546	C4=1/8-T0-1002-F
A10R226	0698-4471	6		RESISTOR 7.15K 1% .125W F TC=0+-100	24546	C4=1/8-T0-7151-F
A10R227	2100-3109	7	2	RESISTOR-TRMR 2K 10% C 8IDE-ADJ 17-TRN	02111	43P202
A10R230	0757-0458	2		RESISTOR 51.1K 1% .125W F TC=0+-100	24546	C4=1/8-T0-5112-F
A10R231	0757-0349	5		RESISTOR 22.6K 1% .125W F TC=0+-100	24546	C4=1/8-T0-2262-F
A10R232	0757-0349	5		RESISTOR 22.6K 1% .125W F TC=0+-100	24546	C4=1/8-T0-2262-F
A10R233	0757-0458	7		RESISTOR 51.1K 1% .125W F TC=0+-100	24546	C4=1/8-T0-5112-F
A10R234	0757-0280	3		RESISTOR 1K 1% .125W F TC=0+-100	24546	C4=1/8-T0-1001-F
A10R235	2100-3123	0	1	RESISTOR-TRMR 500 10% C 8IDE-ADJ 17-TRN	02111	43P501
A10R236	0698-4014	3	1	RESISTOR 787 1% .125W F TC=0+-100	24546	C4=1/8-T0-787R-F
A10R237	0757-0458	7		RESISTOR 51.1K 1% .125W F TC=0+-100	24546	C4=1/8-T0-5112-F
A10R238	0757-0458	7		RESISTOR 51.1K 1% .125W F TC=0+-100	24546	C4=1/8-T0-5112-F
A10R239	0757-0458	7		RESISTOR 51.1K 1% .125W F TC=0+-100	24546	C4=1/8-T0-5112-F
A10R240	0698-0082	7		RESISTOR 464 1% .125W F TC=0+-100	24546	C4=1/8-T0-4640-F
A10R241	2100-3122	9	2	RESISTOR-TRMR 100 10% C 8IDE-ADJ 17-TRN	02111	43P101
A10R242	0757-0442	9		RESISTOR 10K 1% .125W F TC=0+-100	24546	C4=1/8-T0-1002-F
A10R243	0698-4486	3		RESISTOR 24.9K 1% .125W F TC=0+-100	24546	C4=1/8-T0-2492-F
A10R244	0757-0458	7		RESISTOR 51.1K 1% .125W F TC=0+-100	24546	C4=1/8-T0-5112-F
A10R245	0698-0082	7		RESISTOR 464 1% .125W F TC=0+-100	24546	C4=1/8-T0-4640-F
A10R246	0698-3132	4		RESISTOR 261 1% .125W F TC=0+-100	24546	C4=1/8-T0-2610-F
A10U1	1820-1199	1		IC INV TTL LS HEX 1-INP	01295	SN74LS04N
A10U2	1820-1423	4		IC MV TTL LS MONOSTBL RETRIG DUAL	01295	SN74LS123N
A10U3	1820-1442	7		IC CNTR TTL LS DECD ASYNCHRO	01295	SN74LS290N
A10U4	1820-1442	7		IC CNTR TTL LS DECD ASYNCHRO	01295	SN74LS290N
A10U5	1820-1244	7	1	IC MUX/DATA=SEL TTL LS 4-T0=1=LINE DUAL	01295	SN74LS153N
A10U6	1820-0629	0		IC FF TTL S J-K NEG-EDGE-TRIG	01295	SN74LS112N
A10U7	1820-1197	9		IC GATE TTL LS NAND QUAD 2-INP	01295	SN74LS00N
A10U8	1820-1212	9	1	IC FF TTL LS J-K NEG-EDGE-TRIG	01295	SN74LS112N
A10U9	1820-1197	9		IC GATE TTL LS NAND QUAD 2-INP	01295	SN74LS00N
A10U10	1820-1262	9	1	IC CNTR TTL DECD ASYNCHRO NEG-EDGE-TRIG	01295	SN74LS90N

Table 6--3. Replaceable Parts (cont'd)

Reference Designation	HP Part Number	C D	Qty	Description	Mfr Code	Mfr Part Number
A10U11	1820-1443	8	1	IC CNTR TTL LS BIN ASYNCRD	01295	8N74LS293N
A10U12	1820-1197	9		IC GATE TTL LS NAND QUAD 2-INP	01295	8N74LS00N
A10U13	1820-1144	6		IC GATE TTL LS NOR QUAD 2-INP	01295	8N74LS02N
A10U14	1820-1197	9		IC GATE TTL LS NAND QUAD 2-INP	01295	8N74LS00N
A10U15	1820-1211	8	1	IC GATE TTL LS EXCL-OR QUAD 2-INP	01295	8N74LS66N
A10U16	1820-1278	7	1	IC CNTR TTL LS BIN UP/DOWN SYNCRD	01295	8N74LS191N
A10U17	1820-1278	7		IC CNTR TTL LS BIN UP/DOWN SYNCRD	01295	8N74LS191N
A10U18	1820-1278	7		IC CNTR TTL LS BIN UP/DOWN SYNCRD	01295	8N74LS191N
A10U19	1820-1284	5	1	IC GATE TTL LS AND-OR-INV 4-INP	01295	8N74LS55N
A10U20	1820-1207	2	2	IC GATE TTL LS NAND 8-INP	01295	8N74LS30N
A10U21	1820-1207	2		IC GATE TTL LS NAND 8-INP	01295	8N74LS30N
A10U101	1820-1745	3		IC GATE CMOS NOR QUAD 2-INP	04713	MC140018CP
A10U102	1820-1745	3		IC GATE CMOS NOR QUAD 2-INP	04713	MC140018CP
A10U103	1820-1963	7		IC FF CMOS D-TYPE POS-EDGE-TRIG DUAL	01928	CD40138AE
A10U104	1820-1956	8		IC LCH CMOS COM CLOCK QUAD	01928	CD40428E
A10U105	1820-1956	8		IC LCH CMOS COM CLOCK QUAD	01928	CD40428E
A10U106	1820-1956	8		IC LCH CMOS COM CLOCK QUAD	01928	CD40428E
A10U201	1826-0188	8		IC CONV 8-B-D/A 16-DIP-C	04713	MC1408L-8
A10U202	1826-0111	7		IC OP AMP GP DUAL TO-99	04713	MC1458G
A10U203	1826-0111	7		IC OP AMP GP DUAL TO-99	04713	MC1458G
A10U204	1826-0111	7		IC OP AMP GP DUAL TO-99	04713	MC1458G
A10VR201	1902-0025	4		DIODE-ZNR 10V 5% DO-7 PDB,4W TC=+.06%	28480	1902-0025
A10VR202	1902-0041	4		DIODE-ZNR 5.11V 5% DO-7 PDB,4W TC=+.009%	28480	1902-0041
A10VR203	1902-0786	4		DIODE-ZNR 1N937 9V 5% DO-7 PDB,5W	24046	1N937
A10VR204	1902-0786	4		DIODE-ZNR 1N937 9V 5% DO-7 PDB,5W	24046	1N937
A10VR205	1902-0025	4		DIODE-ZNR 10V 5% DO-7 PDB,4W TC=+.06%	28480	1902-0025
A12	08165-66512	7	1	BOARD ASSEMBLY, OFFSET GENERATOR	28480	08165-66512
A12C1	0160-0174	9		CAPACITOR-FXD .47UF +80-20% 25VDC CER	28480	0160-0174
A12C2	0140-0193	0		CAPACITOR-FXD 82PF +-5% 300VDC MICA	72136	DM15E820J0300WV1CR
A12C3	0160-4209	9		CAPACITOR-FXD .01UF +-20% 50VDC POLYE	28480	0160-4209
A12C4	0160-4209	9		CAPACITOR-FXD .01UF +-20% 50VDC POLYE	28480	0160-4209
A12C5	0140-0191	8	1	CAPACITOR-FXD 56PF +-5% 300VDC MICA	72136	DM15E560J0300WV1CR
A12C6	0140-0193	0		CAPACITOR-FXD 82PF +-5% 300VDC MICA	72136	DM15E820J0300WV1CR
A12C7	0160-4209	9		CAPACITOR-FXD .01UF +-20% 50VDC POLYE	28480	0160-4209
A12C8	0160-4209	9		CAPACITOR-FXD .01UF +-20% 50VDC POLYE	28480	0160-4209
A12C9	0160-2205	1		CAPACITOR-FXD 120PF +-5% 100VDC MICA	28480	0160-2205
A12C10	0180-0375	4		CAPACITOR-FXD 68UF+-10% 20VDC TA	56289	150D686X902082
A12C11	0160-4212	4		CAPACITOR-FXD .068UF +-20% 50VDC POLYE	28480	0160-4212
A12C12	0180-0375	4		CAPACITOR-FXD 68UF+-10% 20VDC TA	56289	150D686X902082
A12C13	0160-4212	4		CAPACITOR-FXD .068UF +-20% 50VDC POLYE	28480	0160-4212
A12CR1	1901-0044	5		DIODE-SWITCHING 50V 50MA 6NS	28480	1901-0044
A12CR2	1901-0044	5		DIODE-SWITCHING 50V 50MA 6NS	28480	1901-0044
A12CR3	1901-0044	5		DIODE-SWITCHING 50V 50MA 6NS	28480	1901-0044
A12CR4	1901-0044	5		DIODE-SWITCHING 50V 50MA 6NS	28480	1901-0044
A12CR5	1901-0044	5		DIODE-SWITCHING 50V 50MA 6NS	28480	1901-0044
A12CR6	1901-0044	5		DIODE-SWITCHING 50V 50MA 6NS	28480	1901-0044
A12F1	2110-0538	6	1	FUSE .5A 125V FAgT-BLO .281X.093	75915	276.500
A12K1	0490-1079	4		RELAY-REED 1A 500MA 100VDC 5VDC-COIL	28480	0490-1079
A12K2	0490-1079	4		RELAY-REED 1A 500MA 100VDC 5VDC-COIL	28480	0490-1079
A12L1	9140-0138	2	1	COIL-MLD 180UH 5% QW65 .155DX.375LG-NOM	28480	9140-0138
A12MP1	1205-0033	6	2	HEAT SINK TO-5/TO-39-CS	28480	1205-0033
A12MP2	1205-0033	6		HEAT SINK TO-5/TO-39-CS	28480	1205-0033
A12Q1	1853-0036	2		TRANSISTOR PNP SI PD=310MW FT=250MHZ	28480	1853-0036
A12Q2	1854-0215	1		TRANSISTOR NPN SI PD=350MW FT=300MHZ	04713	2N3904
A12Q3	1855-0081	1		TRANSISTOR J-FET N-CHAN D-MODE SI	01295	2N5245
A12Q4	1853-0036	2		TRANSISTOR PNP SI PD=310MW FT=250MHZ	28480	1853-0036
A12Q5	1853-0036	2		TRANSISTOR PNP SI PD=310MW FT=250MHZ	28480	1853-0036
A12Q6	1854-0585	8	1	TRANSISTOR NPN SI PD=12.5W FT=50MHZ	04713	MJE182
A12Q7	1853-0400	4		TRANSISTOR PNP SI DARL TO-92 PD=500MW	28480	1853-0400
A12Q8	1853-0036	2		TRANSISTOR PNP SI PD=310MW FT=250MHZ	28480	1853-0036
A12Q9	1854-0215	1		TRANSISTOR NPN SI PD=350MW FT=300MHZ	04713	2N3904
A12Q10	1854-0215	1		TRANSISTOR NPN SI PD=350MW FT=300MHZ	04713	2N3904
A12Q11	1853-0341	2	1	TRANSISTOR PNP SI PD=12.5W FT=50MHZ	04713	MJE172
A12Q12	1854-0039	7	1	TRANSISTOR NPN 2N30538 SI TO-39 PD=1W	01928	2N30538
A12Q13	1853-0045	3	1	TRANSISTOR PNP SI TO-39 PD=5W FT=60MHZ	01928	2N4036
A12R1	0698-4125	7	2	RESISTOR 953 1% .125W F TC=0+-100	24546	C4=1/8-T0=953R-F
A12R2	0698-4411	4		RESISTOR 140 1% .125W F TC=0+-100	24546	C4=1/8-T0=140R-F
A12R3	0698-4453	4		RESISTOR 402 1% .125W F TC=0+-100	24546	C4=1/8-T0=402R-F
A12R4	2100-3349	2	1	RESISTOR-TRMR 100 10% C 8TDE-ADJ 1-TRN	28480	2100-3349
A12R5	0757-0444	1		RESISTOR 12.1K 1% .125W F TC=0+-100	24546	C4=1/8-T0=1212-F

Table 6-3. Replaceable Parts (cont'd)

Reference Designation	HP Part Number	C D	Qty	Description	Mfr Code	Mfr Part Number
A12R6	0757-0444	1		RESISTOR 12.1K 1% .125W F TC0+/-100	24546	C4=1/8-T0=1212-F
A12R7	0757-0444	1		RESISTOR 12.1K 1% .125W F TC0+/-100	24546	C4=1/8-T0=1212-F
A12R8	0757-0444	1		RESISTOR 12.1K 1% .125W F TC0+/-100	24546	C4=1/8-T0=1212-F
A12R9	0698-4541	1	1	RESISTOR 442K 1% .125W F TC0+/-100	26480	0698-4541
A12R10	0683-3055	9	1	RESISTOR 3M 5% .25W FC TC=900/+1100	01121	C83055
A12R11	0698-4497	6	2	RESISTOR 48.7K 1% .125W F TC0+/-100	24546	C4=1/8-T0=4872-F
A12R12	2100-3358	3		RESISTOR-TRMR 1M 20% C SIDE-ADJ 1-TRN	26480	2100-3358
A12R13	0683-3355	2	2	RESISTOR 3.3M 5% .25W FC TC=900/+1100	01121	C83355
A12R14	0757-0401	0		RESISTOR 100 1% .125W F TC0+/-100	24546	C4=1/8-T0=101-F
A12R15	0698-4453	4		RESISTOR 402 1% .125W F TC0+/-100	24546	C4=1/8-T0=402R-F
A12R16	0757-0346	2		RESISTOR 10 1% .125W F TC0+/-100	24546	C4=1/8-T0=10R0-F
A12R17	0757-0988	8	2	RESISTOR 15 1% .5W F TC0+/-100	26480	0757-0988
A12R18	0757-0411	2		RESISTOR 332 1% .125W F TC0+/-100	24546	C4=1/8-T0=332R-F
A12R20	2100-3354	9		RESISTOR-TRMR 50K 10% C SIDE-ADJ 1-TRN	26480	2100-3354
A12R21	0698-5094	1		RESISTOR 5.1M 5% .25W FC TC=900/+1100	01121	C80555
A12R22	0683-1065	7		RESISTOR 10M 5% .25W FC TC=900/+1100	01121	C81065
A12R23	2100-3122	9		RESISTOR-TRMR 100 10% C SIDE-ADJ 17-TRN	02111	43P101
A12R24	0698-4125	7		RESISTOR 953 1% .125W F TC0+/-100	24546	C4=1/8-T0=953R-F
A12R25	0757-0444	1		RESISTOR 12.1K 1% .125W F TC0+/-100	24546	C4=1/8-T0=1212-F
A12R26	0757-0444	1		RESISTOR 12.1K 1% .125W F TC0+/-100	24546	C4=1/8-T0=1212-F
A12R27	0757-0444	1		RESISTOR 12.1K 1% .125W F TC0+/-100	24546	C4=1/8-T0=1212-F
A12R28	0698-4497	1		RESISTOR 48.7K 1% .125W F TC0+/-100	24546	C4=1/8-T0=4872-F
A12R29	0757-0280	3		RESISTOR 1K 1% .125W F TC0+/-100	24546	C4=1/8-T0=1001-F
A12R30	0683-3355	2		RESISTOR 3.3M 5% .25W FC TC=900/+1100	01121	C83355
A12R31	2100-3358	3		RESISTOR-TRMR 1M 20% C SIDE-ADJ 1-TRN	26480	2100-3358
A12R32	0757-0401	0		RESISTOR 100 1% .125W F TC0+/-100	24546	C4=1/8-T0=101-F
A12R33	0698-4453	4		RESISTOR 402 1% .125W F TC0+/-100	24546	C4=1/8-T0=402R-F
A12R34	0757-0346	2		RESISTOR 10 1% .125W F TC0+/-100	24546	C4=1/8-T0=10R0-F
A12R35	0757-0988	8		RESISTOR 15 1% .5W F TC0+/-100	26480	0757-0988
A12R36	0757-0411	2		RESISTOR 332 1% .125W F TC0+/-100	24546	C4=1/8-T0=332R-F
A12R37	0757-0280	3		RESISTOR 1K 1% .125W F TC0+/-100	24546	C4=1/8-T0=1001-F
A12R38	0757-0280	3		RESISTOR 1K 1% .125W F TC0+/-100	24546	C4=1/8-T0=1001-F
A12R40	0698-3444	1		RESISTOR 316 1% .125W F TC0+/-100	24546	C4=1/8-T0=316R-F
A12R41	0698-4433	0		RESISTOR 2.26K 1% .125W F TC0+/-100	24546	C4=1/8-T0=2261-F
A12R43	0698-3444	1		RESISTOR 316 1% .125W F TC0+/-100	24546	C4=1/8-T0=316R-F
A12R43	0698-4433	0		RESISTOR 2.26K 1% .125W F TC0+/-100	24546	C4=1/8-T0=2261-F
A12U1	1820-1745	3		IC GATE CMOS NOR QUAD 2-INP	04713	MC14001BCP
A12U2	1826-0059	2		IC OP AMP GP T0=99	01295	LM201AL
A12U3	1826-0059	2		IC OP AMP GP T0=99	01295	LM201AL
A12U4	1826-0059	2		IC OP AMP GP T0=99	01295	LM201AL
A12VR1	1902-0025	4		DIODE-ZNR 10V 5% DO-7 PDS .4W TC+ .06%	26480	1902-0025
A12VR2	1902-3224	1	2	DIODE-ZNR 17.8V 5% DO-7 PDS .4W TC+ .067%	26480	1902-3224
A12VR3	1902-3224	1		DIODE-ZNR 17.8V 5% DO-7 PDS .4W TC+ .067%	26480	1902-3224
A14	08165-66514	9	1	BOARD ASSEMBLY, HP-IB	26480	08165-66514
A14C1	0160-1715	8		CAPACITOR-FXD 150UF+/-10% 6VDC TA	56289	150D157X9006R2
A14C2	0160-0174	9		CAPACITOR-FXD .47UF +80-20% 25VDC CER	26480	0160-0174
A14C3	0160-2055	9		CAPACITOR-FXD .01UF +80-20% 100VDC CER	26480	0160-2055
A14C4	0160-2055	9		CAPACITOR-FXD .01UF +80-20% 100VDC CER	26480	0160-2055
A14C5	0160-2055	9		CAPACITOR-FXD .01UF +80-20% 100VDC CER	26480	0160-2055
A14C6	0160-3455	5	1	CAPACITOR-FXD 470PF +/-10% 1KVDC CER	26480	0160-3455
A14J1	1251-3283	1	1	CONNECTOR 24-PIN F MICROPIB80N	26480	1251-3283
A14J3	1200-0485	2	1	SOCKET-IC 14-CONT DIP DIP-SLDR	26480	1200-0485
A14MP1	0380-0643	3	1	STANDOFF-HEX .255-IN-LG 6-32TMD	00000	ORDER BY DESCRIPTION
A14MP2	08165-00205	7	1	PANEL, HIDDEN	26480	08165-00205
A14R1	1810-0136	3	2	NETWORK-RES 10-81P MULTI-VALUE	26480	1810-0136
A14R2	1810-0136	3		NETWORK-RES 10-81P MULTI-VALUE	26480	1810-0136
A14R3	0757-0442	9		RESISTOR 10K 1% .125W F TC0+/-100	24546	C4=1/8-T0=1002-F
A14R4	0757-0442	9		RESISTOR 10K 1% .125W F TC0+/-100	24546	C4=1/8-T0=1002-F
A14R5	0757-0442	9		RESISTOR 10K 1% .125W F TC0+/-100	24546	C4=1/8-T0=1002-F
A14R6	0757-0442	9		RESISTOR 10K 1% .125W F TC0+/-100	24546	C4=1/8-T0=1002-F
A14R7	0757-0442	9		RESISTOR 10K 1% .125W F TC0+/-100	24546	C4=1/8-T0=1002-F
A14R8	0757-0442	9		RESISTOR 10K 1% .125W F TC0+/-100	24546	C4=1/8-T0=1002-F
A14R9	0757-0407	6		RESISTOR 200 1% .125W F TC0+/-100	24546	C4=1/8-T0=201-F
A14S1	3101-1860	1	1	SWITCH-SL 5-1A DIP-SLIDE-ASSY .1A 50VDC	26480	3101-1860
A14U1	1820-1481	4		IC NMOS	04713	MC6821L
A14U2	1820-1481	4		IC NMOS	04713	MC6821L
A14U3	1820-1824	7	1	IC BFR TTL 8 OCYCL 1-INP	01295	SN748241N
A14U4	1820-1451	8		IC GATE TTL 5 NAND QUAD 2-INP	01295	SN74838N
A14U5	1820-1197	9		IC GATE TTL L8 NAND QUAD 2-INP	01295	SN74LS00N
A14U6	1820-1416	5	2	IC SCHMITT-TRIG TTL L8 INV HEX 1-INP	01295	SN74LS14N
A14U7	1820-1197	9		IC GATE TTL L8 NAND QUAD 2-INP	01295	SN74LS00N
A14U8	1820-1208	3		IC GATE TTL L8 OR QUAD 2-INP	01295	SN74LS32N
A14U9	1820-1416	5		IC SCHMITT-TRIG TTL L8 INV HEX 1-INP	01295	SN74LS14N

Table 6-3. Replaceable Parts (cont'd)

Reference Designation	HP Part Number	C D	Qty	Description	Mfr Code	Mfr Part Number
A10K1	5081-1979	1	1	CABLE, RIBBON 279MM	28480	5081-1979
A15	08165-66515	0	1	BOARD ASSEMBLY, RAMP ADJUST	28480	08165-66515
A15R33	2100-3162	7	2	RESISTOR-TRMR 200K 10% C SIDE-ADJ 17-TRN	02111	43P204
A15R35	2100-3052	4	3	RESISTOR-TRMR 50 10% C SIDE-ADJ 17-TRN	02111	43P500
A15R37	2100-3052	4		RESISTOR-TRMR 50 10% C SIDE-ADJ 17-TRN	02111	43P500
A15R39	2100-3162	7		RESISTOR-TRMR 200K 10% C SIDE-ADJ 17-TRN	02111	43P204
A16	08165-66516	1	1	BOARD ASSEMBLY, SOURCES AD	28480	08165-66516
A16R240	2100-3161	6	1	RESISTOR-TRMR 20K 10% C SIDE-ADJ 17-TRN	02111	43P203
A16R243	2100-3103	6		RESISTOR-TRMR 10K 10% C SIDE-ADJ 17-TRN	02111	43P103
A16R250	2100-3103	6		RESISTOR-TRMR 10K 10% C SIDE-ADJ 17-TRN	02111	43P103
A16R430	2100-3103	6		RESISTOR-TRMR 10K 10% C SIDE-ADJ 17-TRN	02111	43P103
A17R230	2100-3052	4		RESISTOR-TRMR 50 10% C SIDE-ADJ 17-TRN	02111	43P500
A17R340	2100-3154	7		RESISTOR-TRMR 1K 10% C SIDE-ADJ 17-TRN	02111	43P102
A17R360	2100-3109	2		RESISTOR-TRMR 2K 10% C SIDE-ADJ 17-TRN	02111	43P202

Table 6-3. Replaceable Parts (cont'd)

Reference Designation	HP Part Number	C D	Qty	Description	Mfr Code	Mfr Part Number
A2	08165-66519	4	1	BOARD ASSEMBLY, DISPLAY	28480	08165-66519
A8	08165-66520		1	BD AY VCO CONTROL	28480	08165-66520
A11	08165-66511	6	1	BOARD ASSEMBLY, SWEEP GENERATOR	28480	08165-66511
A13	08165-66513	8	1	BOARD ASSEMBLY, AMPLITUDE MODULATION	28480	08165-66513
J6	1250-0118	3	1	CONNECTOR-RF BNC FEM SGL-HOLE-FR 50-OHM	28480	1250-0118
MP7	08165-00206	8	1	PANEL, FRONT (FOR OPT 002 ONLY)	28480	08165-00206
MP14	08165-28102	1	1	WINDOW	28480	08165-28102
W10	08165-61610	6	2	CABLE ASSEMBLY, AM OUTPUT	28480	08165-61610
W11	08165-61610	6	6	CABLE ASSEMBLY, AM OUTPUT	28480	08165-61610
CR4 (A8)	1901-0040	1	3	DIODE-SWITCHING 30 V 50 MA 2 NS DO-35	28480	1901-0040
CR407 (A8)	1901-0040	1	1	DIODE-SWITCHING 30 V 50 MA 2 NS DO-35	28480	1901-0040
K403 (A8)	0490-1079	4	2	RELAY-REED 1 A 50 MA 100 VDC 5 VDC-COIL	28480	0490-1079
Q414 (A8)	1854-0215	1	2	TRANSISTOR NPN SI PD = 350 MW FT = 300 MHZ	04713	2N3904
R441 (A8)	0757-0439	4	2	RESISTOR 6.81K 1% .125 W F TC = 0 + - 100	24546	C4-1/8-TO-6811-F
R501 (A8)	0757-0442	9	2	RESISTOR 10 K 1% .125 W F TC = 0 + - 100	24546	C4-1/8-TO-1002-F
U607 (A8)	1820-1747	5	2	IC GATE CMOS NAND QUAD 2-INP	04713	MC14011BCP

Table 6-3. Replaceable Parts (cont'd)

Reference Designation	HP Part Number	C D	Qty	Description	Mfr Code	Mfr Part Number
A2	08165-66519	4	1	BOARD ASSEMBLY, DISPLAY	28480	08165-66519
A2C1	0160-0174	9	2	CAPACITOR-FXD .47UF +80-20% 25VDC CER	28480	0160-0174
A2C2	0160-0174	9		CAPACITOR-FXD .47UF +80-20% 25VDC CER	28480	0160-0174
A2C3	0180-1704	5	2	CAPACITOR-FXD 47UF+10% 6VDC TA	56289	1500476x900682
A2C4	0180-1704	5		CAPACITOR-FXD 47UF+10% 6VDC TA	56289	1500476x900682
A2D81	1990-0487	7	31	LED-VISIBLE LUM-INT:IMCD IF=20MA-MAX	28480	5082-4584
A2D82	1990-0487	7		LED-VISIBLE LUM-INT:IMCD IF=20MA-MAX	28480	5082-4584
A2D83	1990-0487	7		LED-VISIBLE LUM-INT:IMCD IF=20MA-MAX	28480	5082-4584
A2D84	1990-0487	7		LED-VISIBLE LUM-INT:IMCD IF=20MA-MAX	28480	5082-4584
A2D85	1990-0487	7		LED-VISIBLE LUM-INT:IMCD IF=20MA-MAX	28480	5082-4584
A2D86	1990-0487	7		LED-VISIBLE LUM-INT:IMCD IF=20MA-MAX	28480	5082-4584
A2D87	1990-0487	7		LED-VISIBLE LUM-INT:IMCD IF=20MA-MAX	28480	5082-4584
A2D88	1990-0487	7		LED-VISIBLE LUM-INT:IMCD IF=20MA-MAX	28480	5082-4584
A2D89	1990-0487	7		LED-VISIBLE LUM-INT:IMCD IF=20MA-MAX	28480	5082-4584
A2D810	1990-0487	7		LED-VISIBLE LUM-INT:IMCD IF=20MA-MAX	28480	5082-4584
A2D811	1990-0487	7		LED-VISIBLE LUM-INT:IMCD IF=20MA-MAX	28480	5082-4584
A2D812	1990-0487	7		LED-VISIBLE LUM-INT:IMCD IF=20MA-MAX	28480	5082-4584
A2D813	1990-0487	7		LED-VISIBLE LUM-INT:IMCD IF=20MA-MAX	28480	5082-4584
A2D814	1990-0487	7		LED-VISIBLE LUM-INT:IMCD IF=20MA-MAX	28480	5082-4584
A2D815	1990-0487	7		LED-VISIBLE LUM-INT:IMCD IF=20MA-MAX	28480	5082-4584
A2D816	1990-0487	7		LED-VISIBLE LUM-INT:IMCD IF=20MA-MAX	28480	5082-4584
A2D817	1990-0487	7		LED-VISIBLE LUM-INT:IMCD IF=20MA-MAX	28480	5082-4584
A2D818	1990-0487	7		LED-VISIBLE LUM-INT:IMCD IF=20MA-MAX	28480	5082-4584
A2D819	1990-0487	7		LED-VISIBLE LUM-INT:IMCD IF=20MA-MAX	28480	5082-4584
A2D820	1990-0487	7		LED-VISIBLE LUM-INT:IMCD IF=20MA-MAX	28480	5082-4584
A2D821	1990-0487	7		LED-VISIBLE LUM-INT:IMCD IF=20MA-MAX	28480	5082-4584
A2D822	1990-0487	7		LED-VISIBLE LUM-INT:IMCD IF=20MA-MAX	28480	5082-4584
A2D823	1990-0487	7		LED-VISIBLE LUM-INT:IMCD IF=20MA-MAX	28480	5082-4584
A2D824	1990-0487	7		LED-VISIBLE LUM-INT:IMCD IF=20MA-MAX	28480	5082-4584
A2D825	1990-0487	7		LED-VISIBLE LUM-INT:IMCD IF=20MA-MAX	28480	5082-4584
A2D826	1990-0487	7		LED-VISIBLE LUM-INT:IMCD IF=20MA-MAX	28480	5082-4584
A2D827	1990-0487	7		LED-VISIBLE LUM-INT:IMCD IF=20MA-MAX	28480	5082-4584
A2D828	1990-0487	7		LED-VISIBLE LUM-INT:IMCD IF=20MA-MAX	28480	5082-4584
A2D829	1990-0487	7		LED-VISIBLE LUM-INT:IMCD IF=20MA-MAX	28480	5082-4584
A2D830	1990-0487	7		LED-VISIBLE LUM-INT:IMCD IF=20MA-MAX	28480	5082-4584
A2D831	1990-0487	7		LED-VISIBLE LUM-INT:IMCD IF=20MA-MAX	28480	5082-4584
A2D832	1990-0485	5	1	LED-VISIBLE LUM-INT:IMCD IF=30MA-MAX	28480	5082-4984
A2D833	2140-0016	8	11	LAMP-INCAND 683 5VDC 60MA T=1-BULB	0000J	683
A2D834	2140-0016	8		LAMP-INCAND 683 5VDC 60MA T=1-BULB	0000J	683
A2D835	2140-0016	8		LAMP-INCAND 683 5VDC 60MA T=1-BULB	0000J	683
A2D836	2140-0016	8		LAMP-INCAND 683 5VDC 60MA T=1-BULB	0000J	683
A2D837	2140-0016	8		LAMP-INCAND 683 5VDC 60MA T=1-BULB	0000J	683
A2D838	2140-0016	8		LAMP-INCAND 683 5VDC 60MA T=1-BULB	0000J	683
A2D839	2140-0016	8		LAMP-INCAND 683 5VDC 60MA T=1-BULB	0000J	683
A2D840	2140-0016	8		LAMP-INCAND 683 5VDC 60MA T=1-BULB	0000J	683
A2D841	2140-0016	8		LAMP-INCAND 683 5VDC 60MA T=1-BULB	0000J	683
A2D842	2140-0016	8		LAMP-INCAND 683 5VDC 60MA T=1-BULB	0000J	683
A2D843	2140-0016	8		LAMP-INCAND 683 5VDC 60MA T=1-BULB	0000J	683
A2D851	1990-0452	6	12	DISPLAY-NUM=SEG 1=CHAR .3=H	28480	5082-7731, CAT C-E
A2D852	1990-0452	6		DISPLAY-NUM=SEG 1=CHAR .3=H	28480	5082-7731, CAT C-E
A2D853	1990-0452	6		DISPLAY-NUM=SEG 1=CHAR .3=H	28480	5082-7731, CAT C-E
A2D854	1990-0452	6		DISPLAY-NUM=SEG 1=CHAR .3=H	28480	5082-7731, CAT C-E
A2D855	1990-0452	6		DISPLAY-NUM=SEG 1=CHAR .3=H	28480	5082-7731, CAT C-E
A2D856	1990-0452	6		DISPLAY-NUM=SEG 1=CHAR .3=H	28480	5082-7731, CAT C-E
A2D857	1990-0452	6		DISPLAY-NUM=SEG 1=CHAR .3=H	28480	5082-7731, CAT C-E
A2D858	1990-0452	6		DISPLAY-NUM=SEG 1=CHAR .3=H	28480	5082-7731, CAT C-E
A2D859	1990-0452	6		DISPLAY-NUM=SEG 1=CHAR .3=H	28480	5082-7731, CAT C-E
A2D860	1990-0452	6		DISPLAY-NUM=SEG 1=CHAR .3=H	28480	5082-7731, CAT C-E
A2D861	1990-0452	6		DISPLAY-NUM=SEG 1=CHAR .3=H	28480	5082-7731, CAT C-E
A2D862	1990-0452	6		DISPLAY-NUM=SEG 1=CHAR .3=H	28480	5082-7731, CAT C-E
A2J4	1200-0589	7	12	SOCKET-IC 14=CONT DIP=8LDR	28480	1200-0589
A2J5	1200-0589	7		SOCKET-IC 14=CONT DIP=8LDR	28480	1200-0589
A2J6	1200-0589	7		SOCKET-IC 14=CONT DIP=8LDR	28480	1200-0589
A2J7	1200-0589	7		SOCKET-IC 14=CONT DIP=8LDR	28480	1200-0589
A2J8	1200-0589	7		SOCKET-IC 14=CONT DIP=8LDR	28480	1200-0589
A2J9	1200-0589	7		SOCKET-IC 14=CONT DIP=8LDR	28480	1200-0589
A2J10	1200-0589	7		SOCKET-IC 14=CONT DIP=8LDR	28480	1200-0589
A2J11	1200-0589	7		SOCKET-IC 14=CONT DIP=8LDR	28480	1200-0589
A2J12	1200-0589	7		SOCKET-IC 14=CONT DIP=8LDR	28480	1200-0589
A2J13	1200-0589	7		SOCKET-IC 14=CONT DIP=8LDR	28480	1200-0589
A2J14	1200-0589	7		SOCKET-IC 14=CONT DIP=8LDR	28480	1200-0589
A2J15	1200-0589	7		SOCKET-IC 14=CONT DIP=8LDR	28480	1200-0589

Table 6-3. Replaceable Parts (cont'd)

Reference Designation	HP Part Number	C D	Qty	Description	Mfr Code	Mfr Part Number
A2Q1	1A54-0215	1	4	TRANSISTOR NPN SI PDB350MW FTE300MHZ	04713	2N3904
A2Q2	1A54-0215	1		TRANSISTOR NPN SI PDB350MW FTE300MHZ	04713	2N3904
A2Q3	1A54-0215	1		TRANSISTOR NPN SI PDB350MW FTE300MHZ	04713	2N3904
A2Q4	1A54-0215	1		TRANSISTOR NPN SI PDB350MW FTE300MHZ	04713	2N3904
A2Q5	1A54-0477	7	2	TRANSISTOR NPN 2N2222A SI TO-18 PDB500MW	04713	2N2222A
A2Q6	1A54-0477	7		TRANSISTOR NPN 2N2222A SI TO-18 PDB500MW	04713	2N2222A
A2R1	0757-0706	8	4	RESISTOR 51.1 1% .25W F TC0+100	24546	C5=1/4-T0=51R1-F
A2R2	0757-0706	8		RESISTOR 51.1 1% .25W F TC0+100	24546	C5=1/4-T0=51R1-F
A2R3	0757-0706	8		RESISTOR 51.1 1% .25W F TC0+100	24546	C5=1/4-T0=51R1-F
A2R4	0757-0706	8		RESISTOR 51.1 1% .25W F TC0+100	24546	C5=1/4-T0=51R1-F
A2R5	0757-0280	3	6	RESISTOR 1K 1% .125W F TC0+100	24546	C4=1/8-T0=1001-F
A2R6	0757-0280	3		RESISTOR 1K 1% .125W F TC0+100	24546	C4=1/8-T0=1001-F
A2R7	0757-0280	3		RESISTOR 1K 1% .125W F TC0+100	24546	C4=1/8-T0=1001-F
A2R8	0757-0280	3		RESISTOR 1K 1% .125W F TC0+100	24546	C4=1/8-T0=1001-F
A2R9	0757-0280	3		RESISTOR 1K 1% .125W F TC0+100	24546	C4=1/8-T0=1001-F
A2R10	0757-0280	3		RESISTOR 1K 1% .125W F TC0+100	24546	C4=1/8-T0=1001-F
A2R11	0757-0281	4	4	RESISTOR 2.74K 1% .125W F TC0+100	24546	C4=1/8-T0=2741-F
A2R12	0757-0281	4		RESISTOR 2.74K 1% .125W F TC0+100	24546	C4=1/8-T0=2741-F
A2R13	0757-0281	4		RESISTOR 2.74K 1% .125W F TC0+100	24546	C4=1/8-T0=2741-F
A2R14	0757-0281	4		RESISTOR 2.74K 1% .125W F TC0+100	24546	C4=1/8-T0=2741-F
A2R15	0698-3155	1	2	RESISTOR 4.64K 1% .125W F TC0+100	24546	C4=1/8-T0=4641-F
A2R16	0698-3155	1		RESISTOR 4.64K 1% .125W F TC0+100	24546	C4=1/8-T0=4641-F
A2R17	0757-0417	8	1	RESISTOR 562 1% .125W F TC0+100	24546	C4=1/8-T0=562R-F
A2R18	1810-0162	5	1	NETWORK-RES 14-DIP4.7K OHM X 13	11235	7601-R4.7K
A2R19	8159-0005	0	3	WIRE 22AWG W PVC 1X22 80C	28480	8159-0005
A2R20	8159-0005	0		WIRE 22AWG W PVC 1X22 80C	28480	8159-0005
A2R21	8159-0005	0		WIRE 22AWG W PVC 1X22 80C	28480	8159-0005
A281	5060-9436	7	26	PUSHBUTTON SWITCH P.C. MOUNT	28480	5060-9436
A282	5060-9436	7		PUSHBUTTON SWITCH P.C. MOUNT	28480	5060-9436
A283	5060-9436	7		PUSHBUTTON SWITCH P.C. MOUNT	28480	5060-9436
A284	5060-9436	7		PUSHBUTTON SWITCH P.C. MOUNT	28480	5060-9436
A285	5060-9436	7		PUSHBUTTON SWITCH P.C. MOUNT	28480	5060-9436
A286	5060-9436	7		PUSHBUTTON SWITCH P.C. MOUNT	28480	5060-9436
A287	5060-9436	7		PUSHBUTTON SWITCH P.C. MOUNT	28480	5060-9436
A288	5060-9436	7		PUSHBUTTON SWITCH P.C. MOUNT	28480	5060-9436
A289	5060-9436	7		PUSHBUTTON SWITCH P.C. MOUNT	28480	5060-9436
A2810	5060-9436	7		PUSHBUTTON SWITCH P.C. MOUNT	28480	5060-9436
A2811	5060-9436	7		PUSHBUTTON SWITCH P.C. MOUNT	28480	5060-9436
A2812	5060-9436	7		PUSHBUTTON SWITCH P.C. MOUNT	28480	5060-9436
A2813	5060-9436	7		PUSHBUTTON SWITCH P.C. MOUNT	28480	5060-9436
A2814	5060-9436	7		PUSHBUTTON SWITCH P.C. MOUNT	28480	5060-9436
A2815	5060-9436	7		PUSHBUTTON SWITCH P.C. MOUNT	28480	5060-9436
A2816	5060-9436	7		PUSHBUTTON SWITCH P.C. MOUNT	28480	5060-9436
A2817	5060-9436	7		PUSHBUTTON SWITCH P.C. MOUNT	28480	5060-9436
A2818	5060-9436	7		PUSHBUTTON SWITCH P.C. MOUNT	28480	5060-9436
A2819	5060-9436	7		PUSHBUTTON SWITCH P.C. MOUNT	28480	5060-9436
A2820	5060-9436	7		PUSHBUTTON SWITCH P.C. MOUNT	28480	5060-9436
A2821	5060-9436	7		PUSHBUTTON SWITCH P.C. MOUNT	28480	5060-9436
A2822	5060-9436	7		PUSHBUTTON SWITCH P.C. MOUNT	28480	5060-9436
A2823	5060-9436	7		PUSHBUTTON SWITCH P.C. MOUNT	28480	5060-9436
A2824	5060-9436	7		PUSHBUTTON SWITCH P.C. MOUNT	28480	5060-9436
A2825	5060-9436	7		PUSHBUTTON SWITCH P.C. MOUNT	28480	5060-9436
A2826	5060-9436	7		PUSHBUTTON SWITCH P.C. MOUNT	28480	5060-9436
A2U1	1820-1200	5	1	IC INV TTL LS HEX	01295	SN74LS05N
A2U2	1820-0628	9	1	IC TTL 64-BIT RAM 60-NS 0-C	01295	SN7489N
A2U3	1820-0491	4	1	IC DCDR TTL 8CD-T0=DEC 4-T0=10-LINE	01295	SN74145N
A2W1	5081-1980	4	2	CABLE, RIBBON 279MM	28480	5081-1980
A2W2	5081-1980	4		CABLE, RIBBON 279MM	28480	5081-1980
A2W3	5081-1981	5	1	CABLE, RIBBON 26C 305MM	28480	5081-1981

Table 6-3. Replaceable Parts (cont'd)

Reference Designation	HP Part Number	C D	Qty	Description	Mfr Code	Mfr Part Number
A11	08165-66511	6	1	BOARD ASSEMBLY, SWEEP GENERATOR	28480	08165-66511
A11C101	0160-4211	3	5	CAPACITOR-FXD .047UF +/-20% 50VDC POLYE	28480	0160-4211
A11C201	0160-4209	9	2	CAPACITOR-FXD .01UF +/-20% 50VDC POLYE	28480	0160-4209
A11C202	0160-0598	1	1	CAPACITOR-FXD 2200PF +/-10% 250VDC	28480	0160-0598
A11C203	0160-4211	3	3	CAPACITOR-FXD .047UF +/-20% 50VDC POLYE	28480	0160-4211
A11C401	0180-0116	1	2	CAPACITOR-FXD 6.8UF +/-10% 35VDC TA	56289	150D685X9035B2
A11C402	0160-0116	1	3	CAPACITOR-FXD 6.8UF +/-10% 35VDC TA	56289	150D685X9035B2
A11C403	0160-4211	3	3	CAPACITOR-FXD .047UF +/-20% 50VDC POLYE	28480	0160-4211
A11C404	0160-4211	3	3	CAPACITOR-FXD .047UF +/-20% 50VDC POLYE	28480	0160-4211
A11C405	0180-1704	5	1	CAPACITOR-FXD 47UF +/-10% 6VDC TA	56289	150D476X9006B2
A11C406	0160-4298	6	1	CAPACITOR-FXD 4700PF +/-20% 250VDC CER	56289	C067F251M472M922-CDH
A11C407	0160-0134	1	1	CAPACITOR-FXD 220PF +/-5% 300VDC MICA	28480	0160-0134
A11C408	0160-4211	3	3	CAPACITOR-FXD .047UF +/-20% 50VDC POLYE	28480	0160-4211
A11C409	0140-0193	0	1	CAPACITOR-FXD 82PF +/-5% 300VDC MICA	72136	DM15E820J0300HV1CR
A11C410	0160-4209	9	9	CAPACITOR-FXD .01UF +/-20% 50VDC POLYE	28480	0160-4209
A11CR401	1901-0044	5	2	DIODE-SWITCHING 50V 50MA 6NS	28480	1901-0044
A11CR402	1901-0044	5	2	DIODE-SWITCHING 50V 50MA 6NS	28480	1901-0044
A11CR403	1901-0460	9	2	DIODE-STABISTOR 30V 150MA DO-7	28480	1901-0460
A11CR404	1901-0460	9	2	DIODE-STABISTOR 30V 150MA DO-7	28480	1901-0460
A11Q101	1854-0215	1	3	TRANSISTOR NPN SI PD=350MW FT=300MHZ	04713	2N3904
A11Q102	1854-0215	1	1	TRANSISTOR NPN SI PD=350MW FT=300MHZ	04713	2N3904
A11Q401	1854-0215	1	1	TRANSISTOR NPN SI PD=350MW FT=300MHZ	04713	2N3904
A11Q402	1853-0036	2	2	TRANSISTOR PNP SI PD=310MW FT=250MHZ	28480	1853-0036
A11Q403	1853-0036	2	2	TRANSISTOR PNP SI PD=310MW FT=250MHZ	28480	1853-0036
A11R101	0757-0442	9	3	RESISTOR 10K 1% .125W F TC=0+/-100	24546	C4=1/8-T0=1002=F
A11R102	0698-4444	3	3	RESISTOR 4.87K 1% .125W F TC=0+/-100	24546	C4=1/8-T0=4871=F
A11R103	0757-0349	5	1	RESISTOR 22.6K 1% .125W F TC=0+/-100	24546	C4=1/8-T0=2262=F
A11R201	0757-0280	3	4	RESISTOR 1K 1% .125W F TC=0+/-100	24546	C4=1/8-T0=1001=F
A11R202	0757-0440	7	1	RESISTOR 7.5K 1% .125W F TC=0+/-100	24546	C4=1/8-T0=7501=F
A11R203	2100-3273	1	1	RESISTOR-TRMP 2K 10% C SIDE=ADJ 1=TRN	28480	2100-3273
A11R401	0698-4435	2	2	RESISTOR 2.49K 1% .125W F TC=0+/-100	24546	C4=1/8-T0=2491=F
A11R402	0698-4435	2	2	RESISTOR 2.49K 1% .125W F TC=0+/-100	24546	C4=1/8-T0=2491=F
A11R403	0698-3700	2	1	RESISTOR 715 1% .125W F TC=0+/-100	24546	C4=1/8-T0=715R=F
A11R404	2100-3122	9	1	RESISTOR-TRMR 100 10% C SIDE=ADJ 17=TRN	02111	43P101
A11R405	0757-0442	9	1	RESISTOR 10K 1% .125W F TC=0+/-100	24546	C4=1/8-T0=1002=F
A11R406	0757-0442	9	1	RESISTOR 10K 1% .125W F TC=0+/-100	24546	C4=1/8-T0=1002=F
A11R407	0757-0280	3	3	RESISTOR 1K 1% .125W F TC=0+/-100	24546	C4=1/8-T0=1001=F
A11R408	0757-0419	0	3	RESISTOR 681 1% .125W F TC=0+/-100	24546	C4=1/8-T0=681R=F
A11R409	0757-0438	3	1	RESISTOR 5.11K 1% .125W F TC=0+/-100	24546	C4=1/8-T0=5111=F
A11R410	2100-3351	6	1	RESISTOR-TRMR 500 10% C SIDE=ADJ 1=TRN	28480	2100-3351
A11R411	0698-0083	8	1	RESISTOR 1.96K 1% .125W F TC=0+/-100	24546	C4=1/8-T0=1961=F
A11R420	0757-0419	0	1	RESISTOR 681 1% .125W F TC=0+/-100	24546	C4=1/8-T0=681R=F
A11R421	0698-4479	4	1	RESISTOR 14K 1% .125W F TC=0+/-100	24546	C4=1/8-T0=1402=F
A11R422	0683-1055	5	1	RESISTOR 1M 5% .25W FC TC=800/+900	01121	CB1055
A11R423	2100-3109	2	1	RESISTOR-TRMR 2K 10% C SIDE=ADJ 17=TRN	02111	43P202
A11R424	0698-3449	6	1	RESISTOR 26.7K 1% .125W F TC=0+/-100	24546	C4=1/8-T0=2672=F
A11R425	0757-0419	0	1	RESISTOR 681 1% .125W F TC=0+/-100	24546	C4=1/8-T0=681R=F
A11R426	2100-3154	7	1	RESISTOR-TRMR 1K 10% C SIDE=ADJ 17=TRN	02111	43P102
A11R427	0757-0465	6	1	RESISTOR 100K 1% .125W F TC=0+/-100	24546	C4=1/8-T0=1003=F
A11R428	2100-3123	0	1	RESISTOR-TRMR 500 10% C SIDE=ADJ 17=TRN	02111	43P501
A11R429	0698-3178	8	2	RESISTOR 487 1% .125W F TC=0+/-100	24546	C4=1/8-T0=487R=F
A11R430	0698-4444	3	3	RESISTOR 4.87K 1% .125W F TC=0+/-100	24546	C4=1/8-T0=4871=F
A11R431	0698-3178	3	3	RESISTOR 487 1% .125W F TC=0+/-100	24546	C4=1/8-T0=487R=F
A11R432	0698-4444	3	3	RESISTOR 4.87K 1% .125W F TC=0+/-100	24546	C4=1/8-T0=4871=F
A11R440	0757-0280	3	3	RESISTOR 1K 1% .125W F TC=0+/-100	24546	C4=1/8-T0=1001=F
A11R441	0757-0280	3	3	RESISTOR 1K 1% .125W F TC=0+/-100	24546	C4=1/8-T0=1001=F
A11U101	1820-1956	8	5	IC LCH CMOS COM CLOCK QUAD	0192B	CD4042BE
A11U102	1820-1956	8	5	IC LCH CMOS COM CLOCK QUAD	0192B	CD4042BE
A11U103	1820-1956	8	5	IC LCH CMOS COM CLOCK QUAD	0192B	CD4042BE
A11U104	1820-1956	8	5	IC LCH CMOS COM CLOCK QUAD	0192B	CD4042BE
A11U105	1820-1956	8	5	IC LCH CMOS COM CLOCK QUAD	0192B	CD4042BE
A11U106	1820-1963	7	3	IC FF CMOS D-TYPE POS-EDGE-TRIG DUAL	0192B	CD4013BAE
A11U107	1820-1963	7	3	IC FF CMOS D-TYPE POS-EDGE-TRIG DUAL	0192B	CD4013BAE
A11U108	1820-1963	7	3	IC FF CMOS D-TYPE POS-EDGE-TRIG DUAL	0192B	CD4013BAE
A11U109	1820-1965	9	1	IC GATE CMOS NOR TPL 3=INP	04713	MC14025BCP
A11U110	1820-1970	6	1	IC GATE CMOS OR QUAD 2=INP	04713	MC14071BCP
A11U111	1820-0629	0	1	IC FF TTL S J=K NEG-EDGE=TRIG	01295	SN748112N
A11U112	1820-1964	8	2	IC FF CMOS J=K POS-EDGE=TRIG DUAL	0192B	CD4027BE
A11U113	1820-1961	5	1	IC GATE CMOS NAND TPL 3=INP	04713	MC14023BCP
A11U114	1820-1747	5	1	IC GATE CMOS NAND QUAD 2=INP	04713	MC14011BCP
A11U201	1826-0180	0	1	IC TIMER TTL MONO/ASTBL	04713	MC1455P1

Table 6-3. Replaceable Parts (cont'd)

Reference Designation	HP Part Number	C D	Qty	Description	Mfr Code	Mfr Part Number
A11U202	1820-1241	4	1	IC MUXR/DATA=8EL CMOS 8=TO=1=LINE 8=INP	04713	MC14512CP
A11U203	1820-1122	0	3	IC CNTR CMOS BCD SYNCHRO DUAL	04713	MC14518BCP
A11U204	1820-1122	0		IC CNTR CMOS BCD SYNCHRO DUAL	04713	MC14518BCP
A11U205	1820-1122	0		IC CNTR CMOS BCD SYNCHRO DUAL	04713	MC14518BCP
A11U301	1820-1964	8		IC FF CMOS J=K POS=EDGE=TRIG DUAL	01928	CD4027BE
A11U302	1820-1114	0	2	IC CNTR CMOS BIN SYNCHRO POS=EDGE=TRIG	04713	MC14516CP
A11U303	1820-1114	0		IC CNTR CMOS BIN SYNCHRO POS=EDGE=TRIG	04713	MC14516CP
A11U304	1820-1340	4	4	IC COMPTR CMOS MAGTD 4=BIT	04713	MC14585BCP
A11U305	1820-1340	4		IC COMPTR CMOS MAGTD 4=BIT	04713	MC14585BCP
A11U306	1820-1340	4		IC COMPTR CMOS MAGTD 4=BIT	04713	MC14585BCP
A11U307	1820-1340	4		IC COMPTR CMOS MAGTD 4=BIT	04713	MC14585BCP
A11U308	1820-2015	2	1	IC GATE CMOS EXCL=OR QUAD	04713	MC14070BCP
A11U309	1820-2037	8	1	IC GATE CMOS AND QUAD 2=INP	04713	MC14081BCP
A11U401	1826-0462	1	1	IC CONV 10=8=D/A 16=DIP=C	04713	MC3410CL
A11U402	1826-0111	7	1	IC OP AMP GP DUAL TC=99	04713	MC1458G
A11U403	1826-0432	5	1	IC 16=DIP=P	32293	ICL 8049 CC PE
A11VR401	1902-0184	6	2	DIODE=ZNR 16.2V 5% DO=7 PDR,4W TC=+.066%	28480	1902-0184
A11VR402	1902-0184	6		DIODE=ZNR 16.2V 5% DO=7 PDR,4W TC=+.066%	28480	1902-0184
A11VR403	1902-0041	4	2	DIODE=ZNR 5.11V 5% DO=7 PDR,4W TC=+.009%	28480	1902-0041
A11VR404	1902-0041	4		DIODE=ZNR 5.11V 5% DO=7 PDR,4W TC=+.009%	28480	1902-0041

Table 6-3. Replaceable Parts (cont'd)

Reference Designation	HP Part Number	C D	Qty	Description	Mfr Code	Mfr Part Number
A13	08165-66513 08165-26513	8 4	1 1	BOARD ASSEMBLY, AMPLITUDE MODULATION PC BOARD, BLANK	28480 28480	08165-66513 08165-26513
A13C1	0160-1746	5	2	CAPACITOR-FXD 15UF+-10% 20VDC TA	56289	150D156X902082
A13C2	0160-1746	5	2	CAPACITOR-FXD 15UF+-10% 20VDC TA	56289	150D156X902082
A13C3	0160-0174	9	5	CAPACITOR-FXD .47UF +80-20% 25VDC CER	28480	0160-0174
A13C4	0160-0174	9	9	CAPACITOR-FXD .47UF +80-20% 25VDC CER	28480	0160-0174
A13C5	0160-0174	9	9	CAPACITOR-FXD .47UF +80-20% 25VDC CER	28480	0160-0174
A13C6	0160-0174	9	9	CAPACITOR-FXD .47UF +80-20% 25VDC CER	28480	0160-0174
A13C7	0160-3879	7	5	CAPACITOR-FXD .01UF +-20% 100VDC CER	28480	0160-3879
A13C8	0160-3879	7	7	CAPACITOR-FXD .01UF +-20% 100VDC CER	28480	0160-3879
A13C100	0160-4209	9	1	CAPACITOR-FXD .01UF +-20% 50VDC POLYE	28480	0160-4209
A13C300	0160-0174	9	9	CAPACITOR-FXD .47UF +80-20% 25VDC CER	28480	0160-0174
A13C301	0160-3879	7	7	CAPACITOR-FXD .01UF +-20% 100VDC CER	28480	0160-3879
A13C302	0160-0576	5	1	CAPACITOR-FXD .1UF +-20% 50VDC CER	28480	0160-0576
A13C303	0160-3879	7	7	CAPACITOR-FXD .01UF +-20% 100VDC CER	28480	0160-3879
A13C304	0160-3879	7	7	CAPACITOR-FXD .01UF +-20% 100VDC CER	28480	0160-3879
A13CR1	1901-0040	1	5	DIODE-SWITCHING 30V 50MA 2NS DO-35	28480	1901-0040
A13CR2	1901-0050	3	2	DIODE-SWITCHING 80V 200MA 2NS DO-35	28480	1901-0050
A13CR100	1901-0460	9	2	DIODE-STABISTOR 30V 150MA DO-7	28480	1901-0460
A13CR101	1901-0040	1	9	DIODE-SWITCHING 30V 50MA 2NS DO-35	28480	1901-0040
A13CR102	1901-0460	9	1	DIODE-STABISTOR 30V 150MA DO-7	28480	1901-0460
A13CR103	1901-0040	1	1	DIODE-SWITCHING 30V 50MA 2NS DO-35	28480	1901-0040
A13CR104	1901-0040	1	3	DIODE-SWITCHING 30V 50MA 2NS DO-35	28480	1901-0040
A13CR105	1901-0050	3	3	DIODE-SWITCHING 80V 200MA 2NS DO-35	28480	1901-0050
A13CR106	1901-0040	1	1	DIODE-SWITCHING 30V 50MA 2NS DO-35	28480	1901-0040
A13K1	0490-1034	1	2	RELAY 2C 12VDC-COIL .5A 350VDC	28480	0490-1034
A13K2	0490-1034	1	4	RELAY 2C 12VDC-COIL .5A 350VDC	28480	0490-1034
A13K3	0490-1079	4	1	RELAY-REED 1A 500MA 100VDC 5VDC-COIL	28480	0490-1079
A13MP1	01801-22301	7	1	HEAT SINK	28480	01801-22301
A13Q1	1854-0215	1	7	TRANSISTOR NPN SI PD=350MW FT=300MHZ	04713	2N3904
A13Q2	1853-0036	2	3	TRANSISTOR PNP SI PD=310MW FT=250MHZ	28480	1853-0036
A13Q3	1854-0215	1	1	TRANSISTOR NPN SI PD=350MW FT=300MHZ	04713	2N3904
A13Q4	1854-0215	1	1	TRANSISTOR NPN SI PD=350MW FT=300MHZ	04713	2N3904
A13Q5	1853-0086	2	3	TRANSISTOR PNP SI PD=310MW FT=40MHZ	27014	2N5087
A13Q6	1853-0036	2	2	TRANSISTOR PNP SI PD=310MW FT=250MHZ	28480	1853-0036
A13Q7	1853-0036	2	2	TRANSISTOR PNP SI PD=310MW FT=250MHZ	28480	1853-0036
A13Q100	1854-0392	5	2	TRANSISTOR NPN SI PD=310MW FT=50MHZ	04713	2N5088
A13Q101	1854-0392	5	5	TRANSISTOR NPN SI PD=310MW FT=50MHZ	04713	2N5088
A13Q102	1854-0215	1	1	TRANSISTOR NPN SI PD=350MW FT=300MHZ	04713	2N3904
A13Q103	1854-0215	1	1	TRANSISTOR NPN SI PD=350MW FT=300MHZ	04713	2N3904
A13Q104	1854-0215	1	2	TRANSISTOR NPN SI PD=350MW FT=300MHZ	04713	2N3904
A13Q105	1853-0086	2	2	TRANSISTOR PNP SI PD=310MW FT=40MHZ	27014	2N5087
A13Q106	1853-0086	2	2	TRANSISTOR PNP SI PD=310MW FT=40MHZ	27014	2N5087
A13Q200	1854-0215	1	1	TRANSISTOR NPN SI PD=350MW FT=300MHZ	04713	2N3904
A13Q301	1853-0218	2	2	TRANSISTOR PNP SI TC=18 PD=360MW	28480	1853-0218
A13Q302	1853-0218	2	2	TRANSISTOR PNP SI TC=18 PD=360MW	28480	1853-0218
A13Q303	1854-0354	9	2	TRANSISTOR NPN SI TC=52 PD=360MW	28480	1854-0354
A13Q304	1854-0354	9	2	TRANSISTOR NPN SI TC=52 PD=360MW	28480	1854-0354
A13Q305	1854-0637	1	1	TRANSISTOR NPN 2N2219A SI TC=5 PD=800MW	01295	2N2219A
A13R1	0757-0438	3	1	RESISTOR 5.11K 1% .125W F TC=0+-100	24546	C4-1/8-T0-5111-F
A13R2	0757-0349	5	4	RESISTOR 22.6K 1% .125W F TC=0+-100	24546	C4-1/8-T0-2262-F
A13R3	0757-0280	3	5	RESISTOR 1K 1% .125W F TC=0+-100	24546	C4-1/8-T0-1001-F
A13R4	0757-0349	5	5	RESISTOR 22.6K 1% .125W F TC=0+-100	24546	C4-1/8-T0-2262-F
A13R5	0757-0349	5	5	RESISTOR 22.6K 1% .125W F TC=0+-100	24546	C4-1/8-T0-2262-F
A13R6	0757-0349	5	5	RESISTOR 22.6K 1% .125W F TC=0+-100	24546	C4-1/8-T0-2262-F
A13R7	0698-4425	0	5	RESISTOR 1.54K 1% .125W F TC=0+-100	24546	C4-1/8-T0-1541-F
A13R8	0757-0123	3	1	RESISTOR 34.8K 1% .125W F TC=0+-100	28480	0757-0123
A13R10	0757-0433	8	1	RESISTOR 3.32K 1% .125W F TC=0+-100	24546	C4-1/8-T0-3321-F
A13R11	0698-4425	0	0	RESISTOR 1.54K 1% .125W F TC=0+-100	24546	C4-1/8-T0-1541-F
A13R12	0757-0401	0	9	RESISTOR 100 1% .125W F TC=0+-100	24546	C4-1/8-T0-101-F
A13R13	0698-4421	6	3	RESISTOR 249 1% .125W F TC=0+-100	24546	C4-1/8-T0-249R-F
A13R14	0757-0401	0	0	RESISTOR 100 1% .125W F TC=0+-100	24546	C4-1/8-T0-101-F
A13R15	0757-0422	5	2	RESISTOR 909 1% .125W F TC=0+-100	24546	C4-1/8-T0-909R-F
A13R100	0757-0338	2	1	RESISTOR 1K 1% .25W F TC=0+-100	24546	C5-1/4-T0-1001-F
A13R101	0698-1055	5	1	RESISTOR 1M 5% .25W FC TC=800/+900	01121	C101055
A13R102	2100-3358	3	1	RESISTOR-TRMR 1M 20% C SIOE-ADJ 1-TRN	28480	2100-3358
A13R103	0757-0442	9	2	RESISTOR 10K 1% .125W F TC=0+-100	24546	C4-1/8-T0-1002-F
A13R104	0698-4421	6	9	RESISTOR 249 1% .125W F TC=0+-100	24546	C4-1/8-T0-249R-F
A13R105	0698-4421	6	6	RESISTOR 249 1% .125W F TC=0+-100	24546	C4-1/8-T0-249R-F
A13R106	0698-0082	7	2	RESISTOR 464 1% .125W F TC=0+-100	24546	C4-1/8-T0-4640-F
A13R107	0698-0082	7	2	RESISTOR 464 1% .125W F TC=0+-100	24546	C4-1/8-T0-4640-F
A13R108	0698-4435	2	6	RESISTOR 2.49K 1% .125W F TC=0+-100	24546	C4-1/8-T0-2491-F
A13R109	0698-4435	2	6	RESISTOR 2.49K 1% .125W F TC=0+-100	24546	C4-1/8-T0-2491-F
A13R110	0757-0416	7	2	RESISTOR 511 1% .125W F TC=0+-100	24546	C4-1/8-T0-511R-F

Table 6-3. Replaceable Parts (cont'd)

Reference Designation	HP Part Number	C D	Qty	Description	Mfr Code	Mfr Part Number
A13R111	0698-8469	2	1	RESISTOR 1.15K 1% .125W F TC0+100	24546	C4=1/8-T0=1151-F
A13R112	0757-0442	9		RESISTOR 10K 1% .125W F TC0+100	24546	C4=1/8-T0=1002-F
A13R120	0757-0407	6	4	RESISTOR 200 1% .125W F TC0+100	24546	C4=1/8-T0=201-F
A13R121	0757-0407	6		RESISTOR 200 1% .125W F TC0+100	24546	C4=1/8-T0=201-F
A13R122	0757-0317	7	1	RESISTOR 1.33K 1% .125W F TC0+100	24546	C4=1/8-T0=1331-F
A13R123	2100-3351	6	1	RESISTOR-TRMR 500 10% C SIDE-ADJ 1-TRN	28480	2100-3351
A13R124	0698-4425	0		RESISTOR 1.54K 1% .125W F TC0+100	24546	C4=1/8-T0=1541-F
A13R125	0757-0401	0		RESISTOR 100 1% .125W F TC0+100	24546	C4=1/8-T0=101-F
A13R126	0757-0401	0		RESISTOR 100 1% .125W F TC0+100	24546	C4=1/8-T0=101-F
A13R127	0757-0417	8	4	RESISTOR 562 1% .125W F TC0+100	24546	C4=1/8-T0=562R-F
A13R128	2100-3095	5	1	RESISTOR-TRMR 200 10% C SIDE-ADJ 17-TRN	02111	43P201
A13R129	0757-0417	8		RESISTOR 562 1% .125W F TC0+100	24546	C4=1/8-T0=562R-F
A13R130	0757-0401	0		RESISTOR 100 1% .125W F TC0+100	24546	C4=1/8-T0=101-F
A13R131	0757-0401	0		RESISTOR 100 1% .125W F TC0+100	24546	C4=1/8-T0=101-F
A13R140	0757-0401	0		RESISTOR 100 1% .125W F TC0+100	24546	C4=1/8-T0=101-F
A13R141	0757-0422	5		RESISTOR 909 1% .125W F TC0+100	24546	C4=1/8-T0=909R-F
A13R142	2100-3350	5	1	RESISTOR-TRMR 200 10% C SIDE-ADJ 1-TRN	28480	2100-3350
A13R143	0757-0407	6		RESISTOR 200 1% .125W F TC0+100	24546	C4=1/8-T0=201-F
A13R144	0757-0407	6		RESISTOR 200 1% .125W F TC0+100	24546	C4=1/8-T0=201-F
A13R200	0757-0394	0	8	RESISTOR 51.1 1% .125W F TC0+100	24546	C4=1/8-T0=511R-F
A13R201	0757-0394	0		RESISTOR 51.1 1% .125W F TC0+100	24546	C4=1/8-T0=511R-F
A13R202	0757-0346	2	2	RESISTOR 10 1% .125W F TC0+100	24546	C4=1/8-T0=10R0-F
A13R203	0757-0346	2		RESISTOR 10 1% .125W F TC0+100	24546	C4=1/8-T0=10R0-F
A13R204	0757-0280	3		RESISTOR 1K 1% .125W F TC0+100	24546	C4=1/8-T0=1001-F
A13R205	0757-0280	3		RESISTOR 1K 1% .125W F TC0+100	24546	C4=1/8-T0=1001-F
A13R206	0757-0280	3		RESISTOR 1K 1% .125W F TC0+100	24546	C4=1/8-T0=1001-F
A13R207	0757-0280	3		RESISTOR 1K 1% .125W F TC0+100	24546	C4=1/8-T0=1001-F
A13R208	0698-4444	3	2	RESISTOR 4.67K 1% .125W F TC0+100	24546	C4=1/8-T0=4671-F
A13R209	0698-4444	3		RESISTOR 4.67K 1% .125W F TC0+100	24546	C4=1/8-T0=4671-F
A13R210	2100-3123	0	1	RESISTOR-TRMR 500 10% C SIDE-ADJ 17-TRN	02111	43P501
A13R211	0698-4435	2		RESISTOR 2.49K 1% .125W F TC0+100	24546	C4=1/8-T0=2491-F
A13R212	0698-4425	0		RESISTOR 1.54K 1% .125W F TC0+100	24546	C4=1/8-T0=1541-F
A13R230	0698-4425	0		RESISTOR 1.54K 1% .125W F TC0+100	24546	C4=1/8-T0=1541-F
A13R231	0757-0401	0		RESISTOR 100 1% .125W F TC0+100	24546	C4=1/8-T0=101-F
A13R232	0757-0416	7		RESISTOR 511 1% .125W F TC0+100	24546	C4=1/8-T0=511R-F
A13R300	0698-4435	2		RESISTOR 2.49K 1% .125W F TC0+100	24546	C4=1/8-T0=2491-F
A13R301	0757-0394	0		RESISTOR 51.1 1% .125W F TC0+100	24546	C4=1/8-T0=511R-F
A13R302	0757-0394	0		RESISTOR 51.1 1% .125W F TC0+100	24546	C4=1/8-T0=511R-F
A13R303	0757-0417	6		RESISTOR 562 1% .125W F TC0+100	24546	C4=1/8-T0=562R-F
A13R304	0757-0417	8		RESISTOR 562 1% .125W F TC0+100	24546	C4=1/8-T0=562R-F
A13R305	0698-4037	0	6	RESISTOR 46.4 1% .125W F TC0+100	24546	C4=1/8-T0=464R-F
A13R306	0698-4435	2		RESISTOR 2.49K 1% .125W F TC0+100	24546	C4=1/8-T0=2491-F
A13R307	0698-4037	0		RESISTOR 46.4 1% .125W F TC0+100	24546	C4=1/8-T0=464R-F
A13R308	0698-4435	2		RESISTOR 2.49K 1% .125W F TC0+100	24546	C4=1/8-T0=2491-F
A13R310	0757-0384	8	2	RESISTOR 20 1% .125W F TC0+100	19701	MF4C1/8-T0=20R0-F
A13R311	0757-0384	8		RESISTOR 20 1% .125W F TC0+100	19701	MF4C1/8-T0=20R0-F
A13R312	0698-4037	0		RESISTOR 46.4 1% .125W F TC0+100	24546	C4=1/8-T0=464R-F
A13R313	0698-4037	0		RESISTOR 46.4 1% .125W F TC0+100	24546	C4=1/8-T0=464R-F
A13R314	0757-0394	0		RESISTOR 51.1 1% .125W F TC0+100	24546	C4=1/8-T0=511R-F
A13R315	0757-0394	0		RESISTOR 51.1 1% .125W F TC0+100	24546	C4=1/8-T0=511R-F
A13R316	0698-4037	0		RESISTOR 46.4 1% .125W F TC0+100	24546	C4=1/8-T0=464R-F
A13R317	0698-4037	0		RESISTOR 46.4 1% .125W F TC0+100	24546	C4=1/8-T0=464R-F
A13R318	0698-3437	2	4	RESISTOR 133 1% .125W F TC0+100	24546	C4=1/8-T0=133R-F
A13R319	0698-3437	2		RESISTOR 133 1% .125W F TC0+100	24546	C4=1/8-T0=133R-F
A13R320	0757-0401	0		RESISTOR 100 1% .125W F TC0+100	24546	C4=1/8-T0=101-F
A13R321	0698-3437	2		RESISTOR 133 1% .125W F TC0+100	24546	C4=1/8-T0=133R-F
A13R322	0698-3437	2		RESISTOR 133 1% .125W F TC0+100	24546	C4=1/8-T0=133R-F
A13R323	0757-0394	0		RESISTOR 51.1 1% .125W F TC0+100	24546	C4=1/8-T0=511R-F
A13R324	0757-0394	0		RESISTOR 51.1 1% .125W F TC0+100	24546	C4=1/8-T0=511R-F
A13U1	1826-0111	7	2	IC OP AMP GP DUAL T0=99	04713	MC1458G
A13U2	1826-0111	7		IC OP AMP GP DUAL T0=99	04713	MC1458G
A13U3	1826-0389	1	1	IC	28480	1826-0389
A13U4	1858-0030	6	1	TRANSISTOR ARRAY 16-PIN CER DIP	28480	1858-0030
A13VR1	1902-0041	4	1	DIODE-ZNR 5.11V 5% DO-7 PDS.4W TC=+.009%	28480	1902-0041
A13VR100	1902-0048	1	1	DIODE-ZNR 6.81V 5% DO-7 PDS.4W TC=+.043%	28480	1902-0048
A13VR200	1902-3048	7	2	DIODE-ZNR 3.48V 5% DO-7 PDS.4W TC=+.058%	28480	1902-3048
A13VR300	1902-3048	7		DIODE-ZNR 3.48V 5% DO-7 PDS.4W TC=+.058%	28480	1902-3048
A13VR301	1902-3203	6	1	DIODE-ZNR 14.7V 5% DO-7 PDS.4W TC=+.057%	28480	1902-3203
A13W1	08165-01609	3	2	CABLE ASSEMBLY, VCO/AM	28480	08165-01609
A13W2	08165-01609	3		CABLE ASSEMBLY, VCO/AM	28480	08165-01609

Free Manuals Download Website

<http://myh66.com>

<http://usermanuals.us>

<http://www.somanuals.com>

<http://www.4manuals.cc>

<http://www.manual-lib.com>

<http://www.404manual.com>

<http://www.luxmanual.com>

<http://aubethermostatmanual.com>

Golf course search by state

<http://golfingnear.com>

Email search by domain

<http://emailbydomain.com>

Auto manuals search

<http://auto.somanuals.com>

TV manuals search

<http://tv.somanuals.com>