

## Replacement Instructions

# hp StorageWorks MSA SAN Switch 2/8

*These instructions apply to the MSA1000 product family. The part may also be used in other HP products. Please refer to documentation for your specific product for detailed replacement instructions.*



If the product in which this part is being replaced is still under HP warranty, then the replacement part(s) referred to in these Replacement Instructions is provided under the terms and conditions of the Hewlett-Packard Company Limited Warranty for that product. A copy of this Limited Warranty may be viewed at:

<http://h18006.www1.hp.com/products/storageworks/warranty.html>

If this is a trade sale part (product out of warranty), then the replacement part(s) referred to in these Replacement Instructions is provided under HP's express limited warranty statement, which may be viewed at:

[http://customerops.corp.hp.com/1sw/pdm\\_om/warranty\\_support/policies/2330100.doc](http://customerops.corp.hp.com/1sw/pdm_om/warranty_support/policies/2330100.doc)

The replacement part takes on either the Limited Warranty Period of the part being replaced or a ninety-day period that begins upon installation of the replacement part, whichever is greater.

The information contained on these replacement instructions is subject to change without notice. The only warranty for this replacement product is as noted above. Nothing in these replacement instructions should be construed as constituting an additional warranty. The information provided in these replacement instructions is provided "AS IS" and HP is not liable for technical or editorial errors or omissions contained herein.

© Copyright 2004 Hewlett-Packard Development Company, L.P.

Please note that this document is protected by federal copyright law and that no part of this document may be copied, reproduced or translated without the prior written consent of Hewlett-Packard Development Company, L.P.

Printed in the USA.

MSA SAN Switch 2/8 Replacement Instructions  
First Edition (April 2004)  
Part Number: 358185-001



358185-001

## About this document

This document details the procedures for replacing a failed MSA SAN Switch 2/8 in HP StorageWorks Modular Smart Array (MSA) storage systems.

## Verifying component failure

Before replacing the switch use the following methods to verify the component failure.

- If the service indicator LED flashes amber, it indicates a failure.
- Check the controller LCD for one of the error messages listed in [Table 1](#).

**Table 1: LCD Error Messages**

No.	Message
514	FIBRE SWITCH HARDWARE FAILURE
515	FIBRE DEVICE HARDWARE FAILURE
516	FIBRE SUBSYSTEM FAILURE

## Before you begin

Read the following cautions and information before beginning removal and replacement procedures.



**WARNING:** To reduce the risk of injury from laser radiation or damage to the equipment, observe the following precautions:

- Do not open any panels, operate controls, make adjustments, or perform procedures to a laser device other than those specified herein.
- Do not stare into the laser beam when panels are open.



**Caution:** Be sure the replacement part is available before removing the failed component. Removing a component impacts cooling within the enclosure.



**Caution:** Parts can be damaged by electrostatic discharge. Use proper anti-static protection. Refer to the documentation that shipped with your system for additional information.



**Caution:** It is important to follow these instructions when replacing components in the MSA. If the procedure is done improperly, it is possible to lose data or damage equipment.

**Note:** Before replacing the MSA SAN Switch 2/8 it is important to stop all system access (for example, application, system I/O, or RAW device file path/s) to the device.

## Step 1: Removing the SFP transceiver



**WARNING:** To reduce the risk of injury from laser radiation or damage to the equipment, observe the following precautions:

- Do not open any panels, operate controls, make adjustments, or perform procedures to a laser device other than those specified herein.
- Do not stare into the laser beam when panels are open.

1. Press the release clip on the bottom of the cable connector ❶ to remove the Fibre Channel cable.
2. Pull the transceiver out of the device by pulling up and out on the plastic tab ❷.

**Note:** Be sure to label each cable with the port it is being removed from.

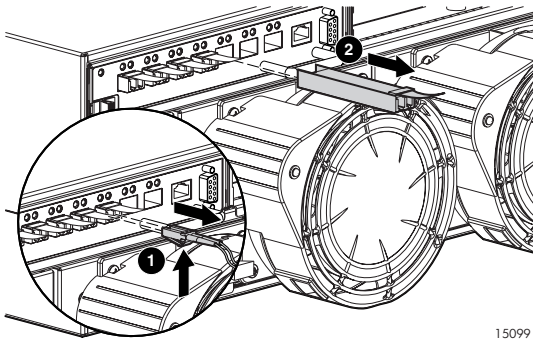

15099

Figure 1: Removing the SFP transceiver



**Caution:** Touching the end of a fibre cable damages the cable. Whenever a fibre cable is not connected, replace the protective covers on the ends of the cables.

## Step 2: Removing the switch

To remove the switch:

1. Slide the port-colored release latch ❶ to the right.
2. Slide the switch ❷ straight out.

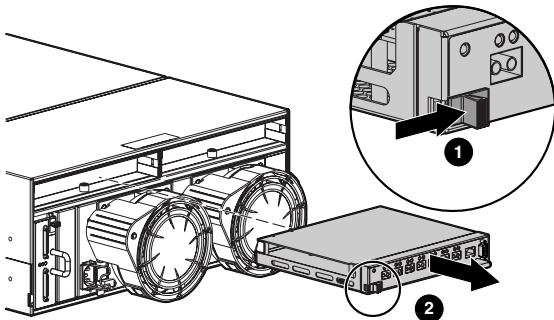

15069

Figure 2: Removing the switch

## Step 3: Installing the switch

To install the new switch:

1. Slide the switch straight in. The release latch should automatically close.
2. Make sure the release latch has closed and is secure.

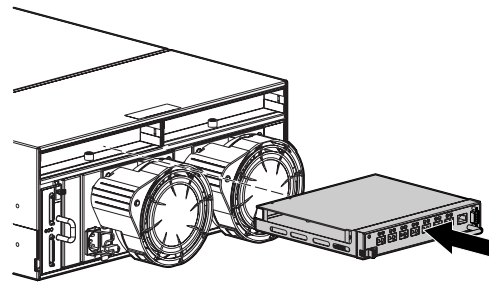

15070

Figure 3: Installing the switch

## Step 4: Installing the SFP transceiver

Insert the SFP transceiver(s) into the new switch and replace the Fibre Channel cable.



**Caution:** To reduce the risk of damage to the equipment, do not use excessive force when inserting the transceiver.

## Step 5: Configuring the switch

Do not connect the switch to a configured SAN without first configuring the switch. Also verify that the replacement switch is working properly.

Refer to chapters 3 and 4 in the *HP StorageWorks MSA SAN Switch 2/8 Installation Guide* for detailed instructions.

**Note:** All switches in the fabric must be running the same version of firmware. Refer to "Upgrading or Restoring the Switch Firmware," in the *HP StorageWorks MSA SAN Switch 2/8 Installation Guide* for detailed instructions.

## Verifying the replacement

After replacing the failed switch be sure that:

- The service indicator LED is solid green. Unread error log messages may cause the LED to remain flashing. Be sure all error messages that have been responded to are deleted.
- No new error messages are displayed on the LCD.

## Returning the failed component

Please follow the return instructions provided in the new component package.

## Additional information

For additional information, refer to the MSA technical documents web site at <http://www.hp.com/go/msa1000>.

## Free Manuals Download Website

<http://myh66.com>

<http://usermanuals.us>

<http://www.somanuals.com>

<http://www.4manuals.cc>

<http://www.manual-lib.com>

<http://www.404manual.com>

<http://www.luxmanual.com>

<http://aubethermostatmanual.com>

Golf course search by state

<http://golfingnear.com>

Email search by domain

<http://emailbydomain.com>

Auto manuals search

<http://auto.somanuals.com>

TV manuals search

<http://tv.somanuals.com>