

Model 89780

! SAFETY INSTRUCTIONS !

FAILURE TO FOLLOW THESE SAFETY INSTRUCTIONS MAY RESULT IN SERIOUS INJURY, PROPERTY DAMAGE AND WILL VOID WARRANTY.

This unit is intended for display purposes only and should not be used for play.

To ensure safety, do not attempt to assemble this system without following the instructions carefully. Check entire box and inside all packing material for parts. Before beginning assembly, read the instructions and identify parts in this document. Proper and complete assembly, use and supervision is essential for proper operation and to reduce the risk of accident or injury. A high probability of serious injury exists if this system is not installed, maintained, and operated properly.

- During assembly, if using a ladder use extreme caution. Two people are recommended for this operation.
- If technical assistance is required, contact Huffy Sports' Sample and Display Technician.
- Serious injury could occur if teeth/face come in contact with backboard, net or rim.
- Display recommended for 3" (7.6 cm) or 3-1/2" (9 cm) Round or 4" (10 cm) Square poles only.
- All instructions and warnings MUST accompany any display item that is sold.

Most injuries are caused by misuse and/or not following instructions.

Use caution when installing this unit.

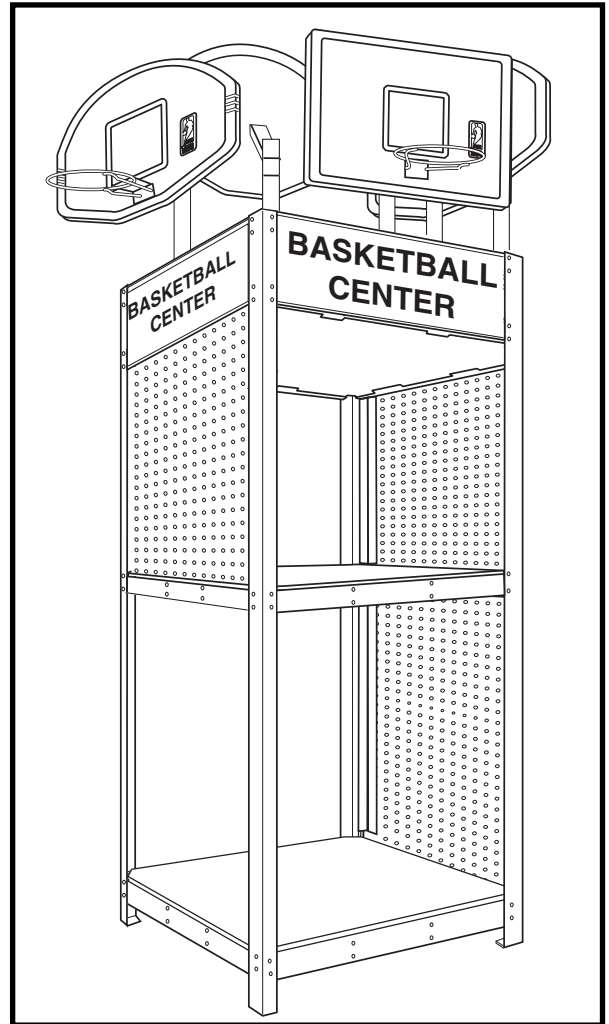

REQUIRED TOOLS AND MATERIALS:

- Wrenches: (Two each) 7/16", 1/2", 9/16", and 3/4" or Pliers
- 3/16" Allen Wrench
- Step Ladder, 8 ft. (2.4 m)

IMPORTANT!

To ensure prompt and correct handling of any problems, or to answer any questions, please contact the Sample and Display Technician at 1-800-558-5234.

Internet Address: <http://www.huffysports.com>

PARTS LIST

<u>Item</u>	<u>Qty.</u>	<u>Part No.</u>	<u>Description</u>
1	2	203257	Zip Tie
2	4	207103	Pole Cap for 3.5" Pole Section
3	26	203100	Nut, Hex Flange 5/16-18*
4	6	204872	Height, Decal
5	8	201611	Bolt, Hex Flange, 5/16-18 x 3"
6	16	203218	Washer, Flat, 5/16*
7	8	200516	Bolt Cover, Vinyl*
8	4	200863	POP Header Cards
9	6	200892	Plastic Push Clips
10	4	900013	3.5" Pole Section
11	1	200862	POP Insert

* YOU MAY HAVE EXTRA HARDWARE



Move display to location on sales floor and remove 2 X 4 runners under feet.

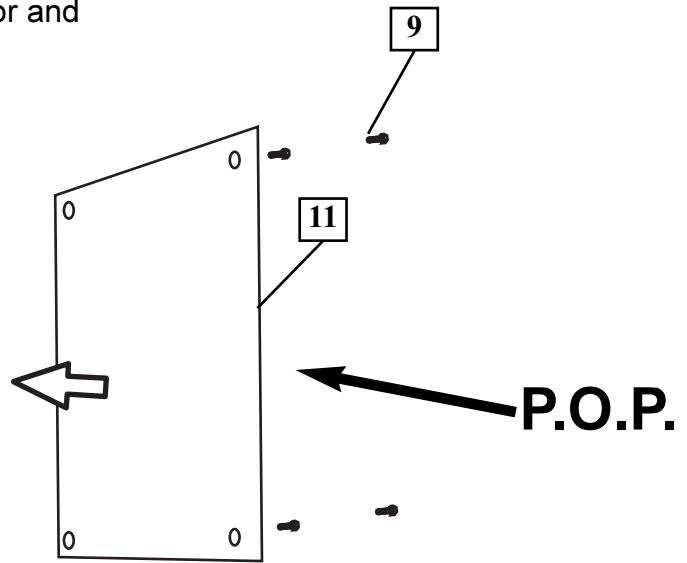
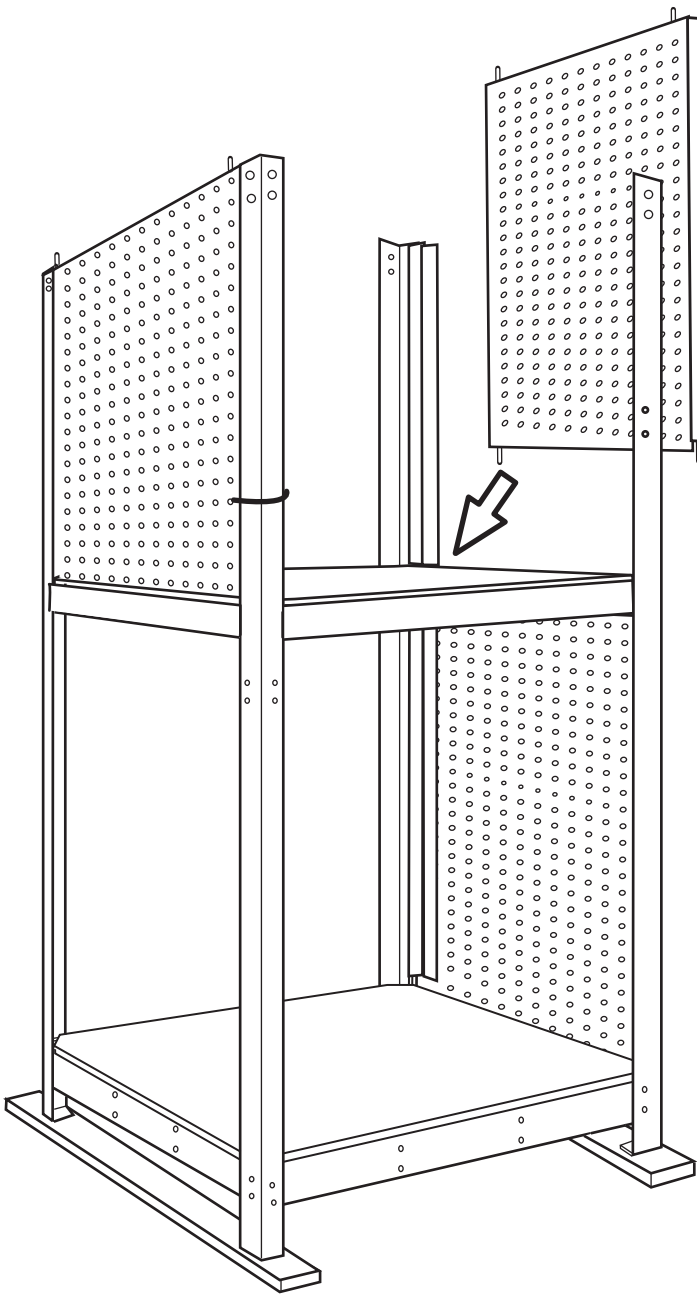

Install pegboard panels onto corresponding side support railings. Secure with zip tie to temporarily hold panel in place. Remove zip ties after assembly is complete. Attach P.O.P. sign (11) with plastic push clips (9) so that it faces aisle as shown.

FRONT





Install support railings, as shown. Insert particle board as shown and rest on second support railing.

⚠️ WARNING

**TWO PERSON MINIMUM
REQUIRED FOR THIS
PROCEDURE. NOT
FOLLOWING
RECOMMENDATION MAY
RESULT IN BODILY INJURY.**

**IMPORTANT:
Top Support Railing Must
Be Inserted In The Positions
Shown. POP Cards Will
Later Be Inserted Into Rail
Slots.**

**NOTE:
Top shelf has
square
corners.**

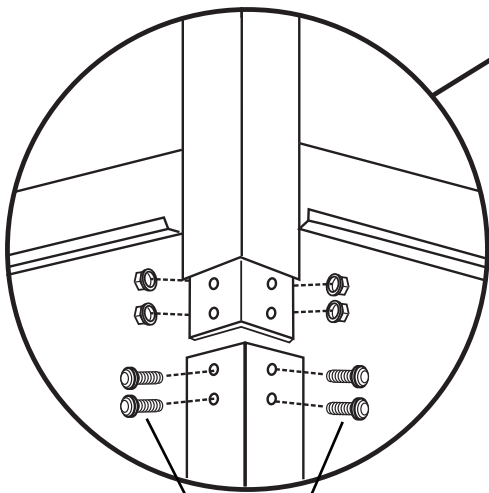
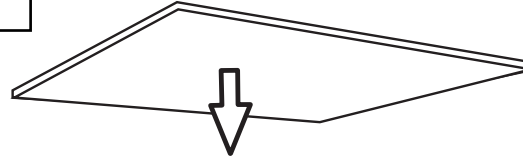

**NOTE:
Use shorter
bolts to
assemble.**

**NOTE:
Location of
tab on lower
panel.**

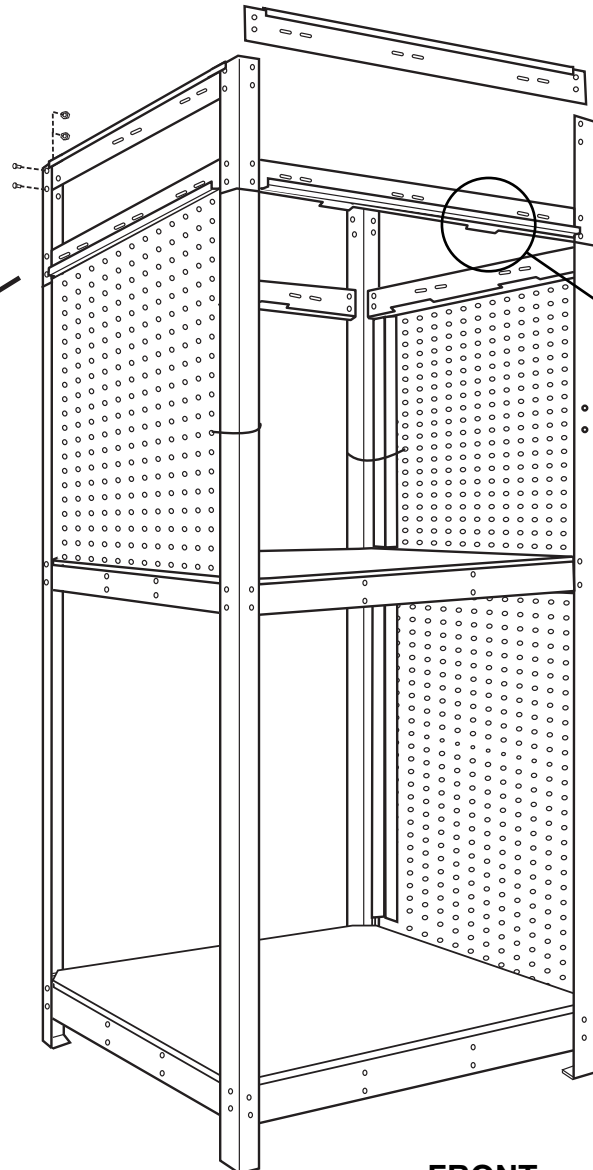

FRONT



Install enclosed pole mounting hardware and pole for each assembly.

⚠ WARNING

TWO PEOPLE ARE NECESSARY TO MOUNT THE ELEVATOR ASSEMBLY TO THE POLE. ONE PERSON SHOULD NOT ATTEMPT TO DO THIS ALONE.

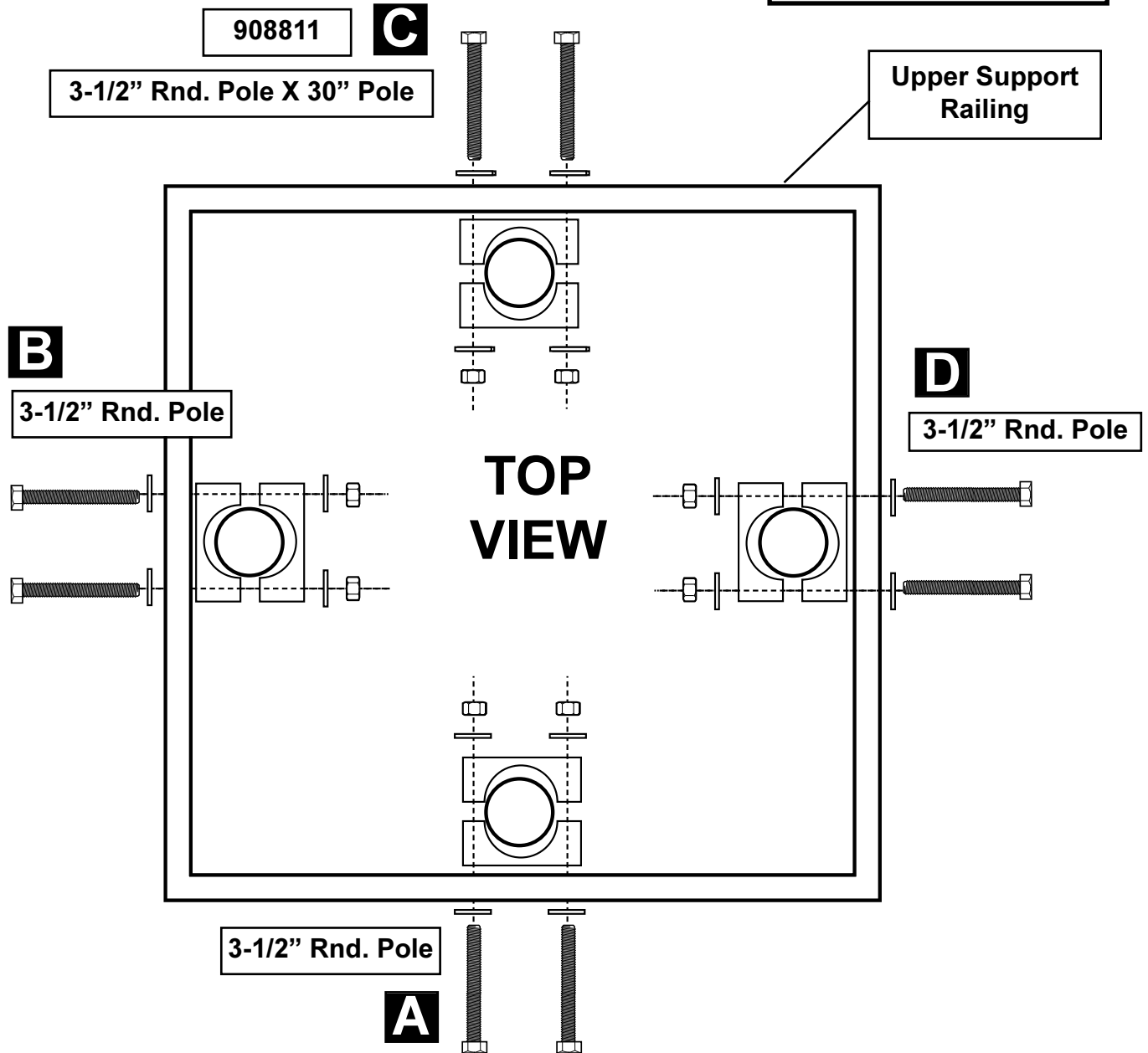

NOTE:
Enclosed One Set
Of Hardware For
(Each) Pole Installation

5

Assemble display products per diagram below and procedures on following pages for each model. Then mount to corresponding backboard hardware.

⚠ WARNING
TWO PERSON MINIMUM
REQUIRED FOR THIS
PROCEDURE. NOT
FOLLOWING
RECOMMENDATION MAY
RESULT IN BODILY INJURY.

⚠ WARNING
MOUNTING THE ELEVATOR
ASSEMBLY TO THE POLE IS
PERFORMED AT AN
ELEVATED HEIGHT. USE
PROPER PRECAUTION.

81410
48" Fan Backboard
w/Slam Jam Rim

C HUFFY TUFF

LINE-UP

73092
44" Fan
Backboard
w/Slam Jam Rim

B

89036 44" SFA
w/Slam Jam Rim
Steel Framed Acrylic

D

CLEAR SLAM

**INSTALLATION
DIAGRAM**

A

**FREE
STYLE**

80550
44" Fan
w/Standard Rim

FRONT

Pole Locations **A B C D**

Refer To Combo For
Goal Assembly
Instructions

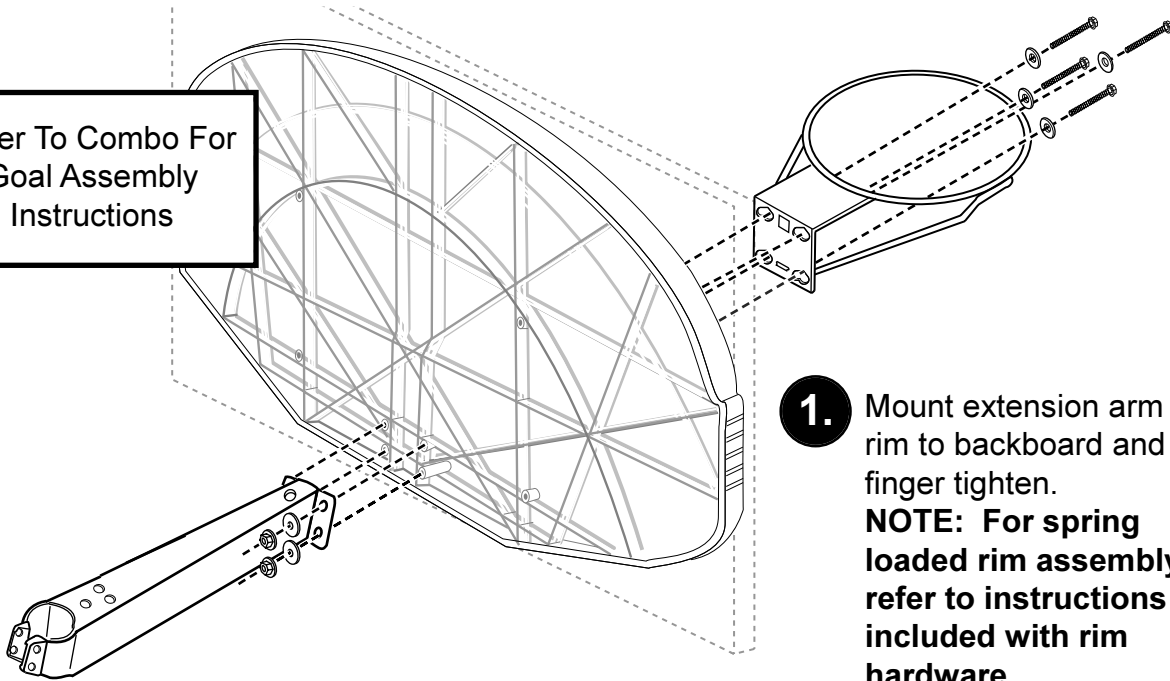

- 1.** Mount extension arm and rim to backboard and finger tighten.
NOTE: For spring loaded rim assembly, refer to instructions included with rim hardware.

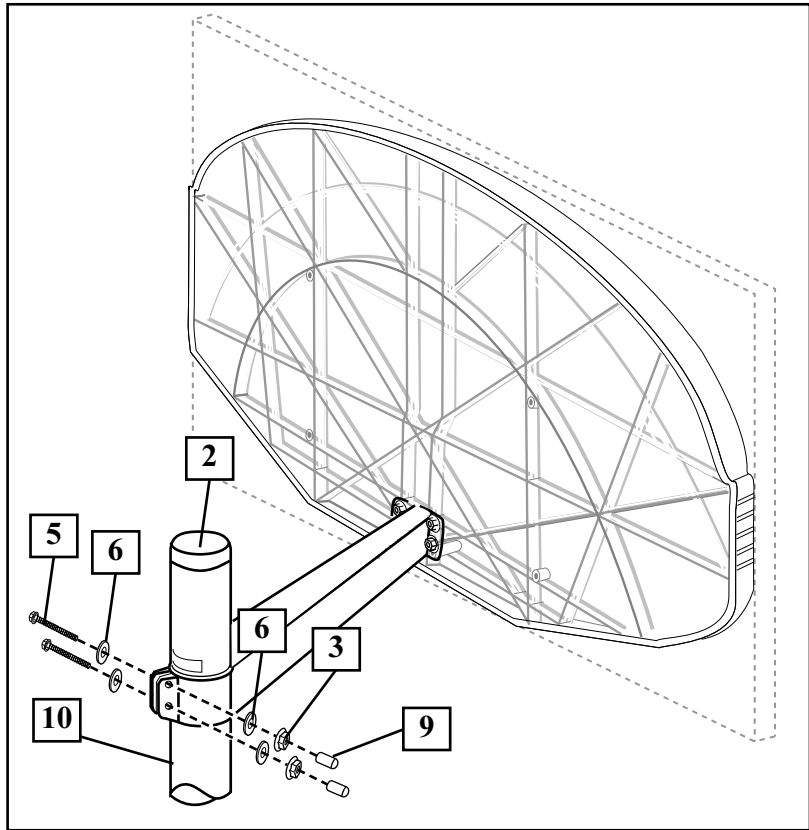

- 2.** Secure hardware to extension arm as shown and tighten completely. install pole cap (2)



Insert header cards (8) into place as shown.

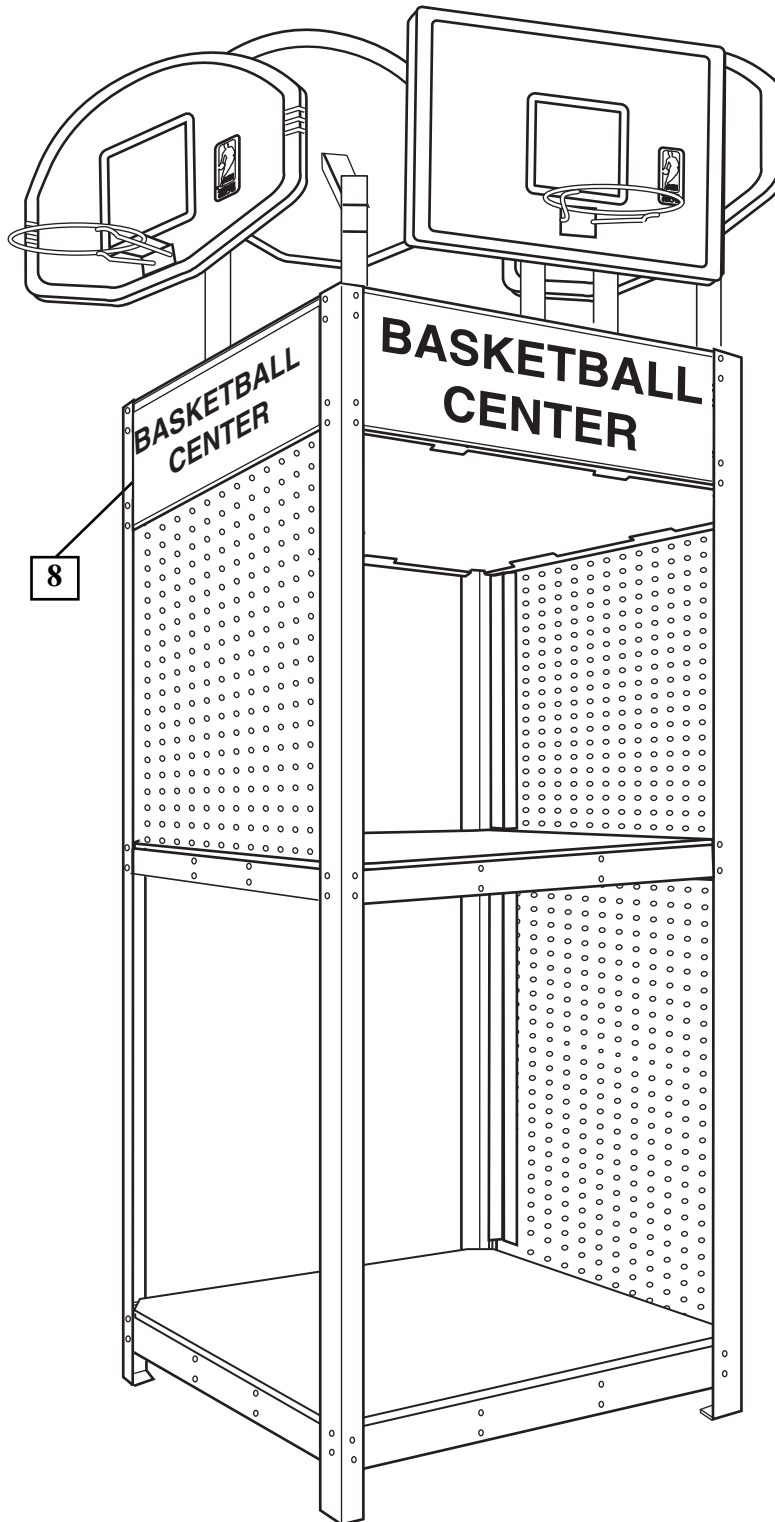

Free Manuals Download Website

<http://myh66.com>

<http://usermanuals.us>

<http://www.somanuals.com>

<http://www.4manuals.cc>

<http://www.manual-lib.com>

<http://www.404manual.com>

<http://www.luxmanual.com>

<http://aubethermostatmanual.com>

Golf course search by state

<http://golfingnear.com>

Email search by domain

<http://emailbydomain.com>

Auto manuals search

<http://auto.somanuals.com>

TV manuals search

<http://tv.somanuals.com>