

# HUFFY<sup>®</sup>SPORTS

A DIVISION OF RUSSELL CORPORATION

## Pool System Owners Manual

Customer Service Center

• N53 W24700 South Corporate Circle • Sussex, WI 53089 • U.S.A.

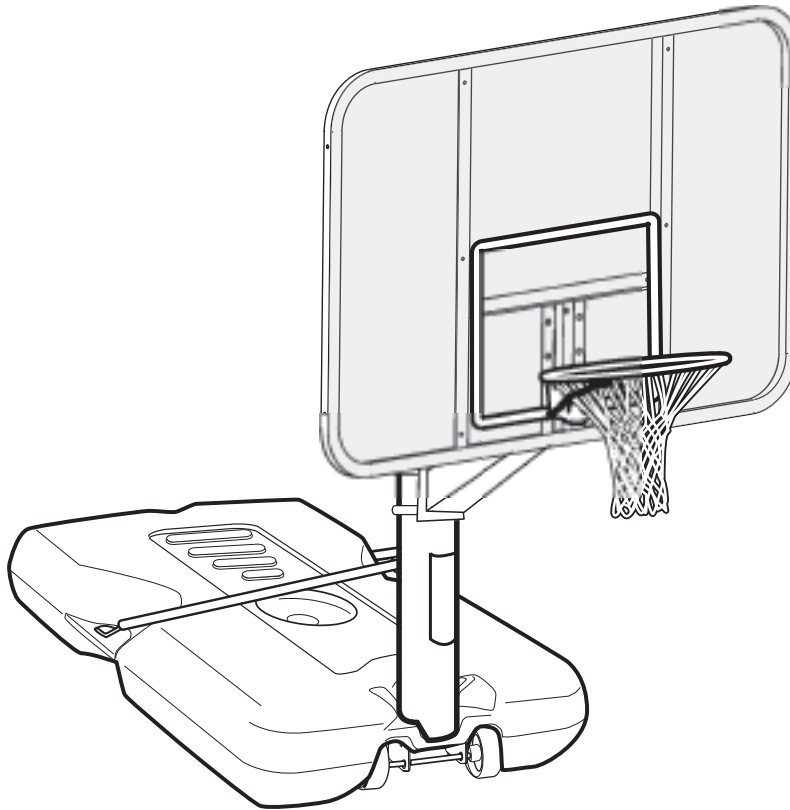

### REQUIRED TOOLS AND MATERIALS:

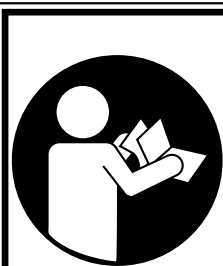

#### **! WARNING!**

READ AND UNDERSTAND  
OPERATOR'S MANUAL  
BEFORE USING THIS UNIT.

FAILURE TO FOLLOW  
OPERATING  
INSTRUCTIONS COULD  
RESULT IN INJURY OR  
DAMAGE TO PROPERTY.



• 2 People

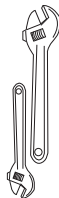

• Optional: Large &  
Small Adjustable  
Wrenches

• (2 each) Wrenches and/or  
Socket Wrenches and  
Sockets. Deep sockets recommended.



1/2" 9/16"

AND/OR



1/2" 9/16"

• Garden Hose or  
Sand



Toll-Free Customer Service Number for U.S: 1-800-558-5234,

For Canada: 1-800-284-8339,

For Europe: 00 800 555 85234 (Sweden: 009 555 85234),

For Australia: 1-800-333 061

Internet Address: <http://www.huffysports.com>



# SAFETY INSTRUCTIONS



**FAILURE TO FOLLOW THESE SAFETY INSTRUCTIONS MAY RESULT IN SERIOUS INJURY OR PROPERTY DAMAGE AND WILL VOID WARRANTY.**

*Owner must ensure that all players know and follow these rules for safe operation of the system.*

To ensure safety, do not attempt to assemble this system without following the instructions carefully. Check entire box and inside all packing material for parts and/or additional instruction material. Before beginning assembly, read the instructions and identify parts using the hardware identifier and parts list in this document. Proper and complete assembly, use and supervision are essential for proper operation and to reduce the risk of accident or injury. A high probability of serious injury exists if this system is not installed, maintained, and operated properly.

- DO NOT position system near trampolines, diving boards, slides, or any play area.
- If using a ladder during assembly, use extreme caution.
- This equipment is intended for home recreational use only and NOT excessive competitive play.
- DO NOT position system near trampolines, diving boards, slides, or any play area equipment. System misuse could cause serious bodily injury.
- Two pole assembly is for in-ground pool side use only.
- Read and understand the warning label affixed to pole.
- The life of your basketball pole depends on many conditions. The climate, placement of the pole, the location of the pole, exposure to corrosives such as chlorine, pesticides, herbicides or salts are all important factors.
- During assembly, if using a ladder use extreme caution. Two people are recommended for this operation.
- Seat the pole sections properly (if applicable). Failure to do so could allow the pole sections to separate during play and/or during transport of the system.
- Climate, corrosion and excessive use or misuse could result in system failure.
- Check tank regularly for leakage. Slow leaks could cause system to tip over unexpectedly.
- If technical assistance is required, contact Huffy Customer Service Center.
- Adult supervision is recommended when adjusting system.

*Most injuries are caused by misuse and/or not following instructions.  
Use caution when using this system.*

13

## MOVING SYSTEM

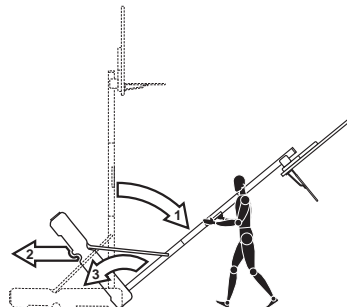

1. While holding pole, rotate basketball system forward until wheels engage with ground.
2. Move basketball system to desired location.
3. Carefully rotate basketball system upright.
4. Reattach ground restraint and check system for stability.

201261 3/99

## NOTICE TO ASSEMBLERS

ALL Huffy Sports Basketball Systems, including those used for DISPLAYS, MUST be assembled and ballasted with sand or water according to instructions. Failure to follow instructions could result in SERIOUS INJURY. It is NOT acceptable to devise a makeshift weight system.

**IMPORTANT!**  
Remove all contents from boxes.  
Be sure to check inside pole sections,  
hardware and additional parts are packed inside.

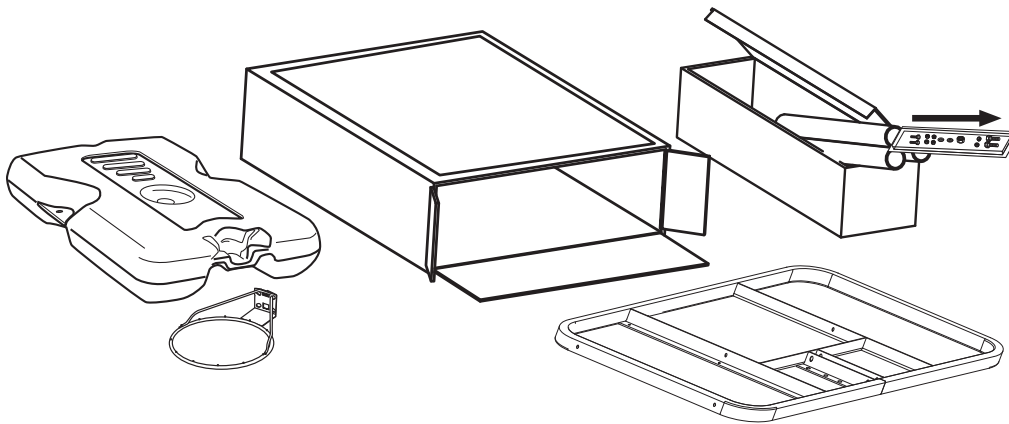



**Questions or Missing Parts?**  
**DON'T go back to store!**  
Call TOLL-FREE Customer Service  
Number listed on the front page!

**WARRANTY CARD:**  
Please remember to complete your product registration form either on-line at:  
[www.huffysports.com/customer\\_support/product\\_registration](http://www.huffysports.com/customer_support/product_registration)  
or mail-in the enclosed postcard.

For more information on assembly, placement, proper use and maintenance, visit The American Basketball Council website at <http://www.smarthoops.com>.

FRONT

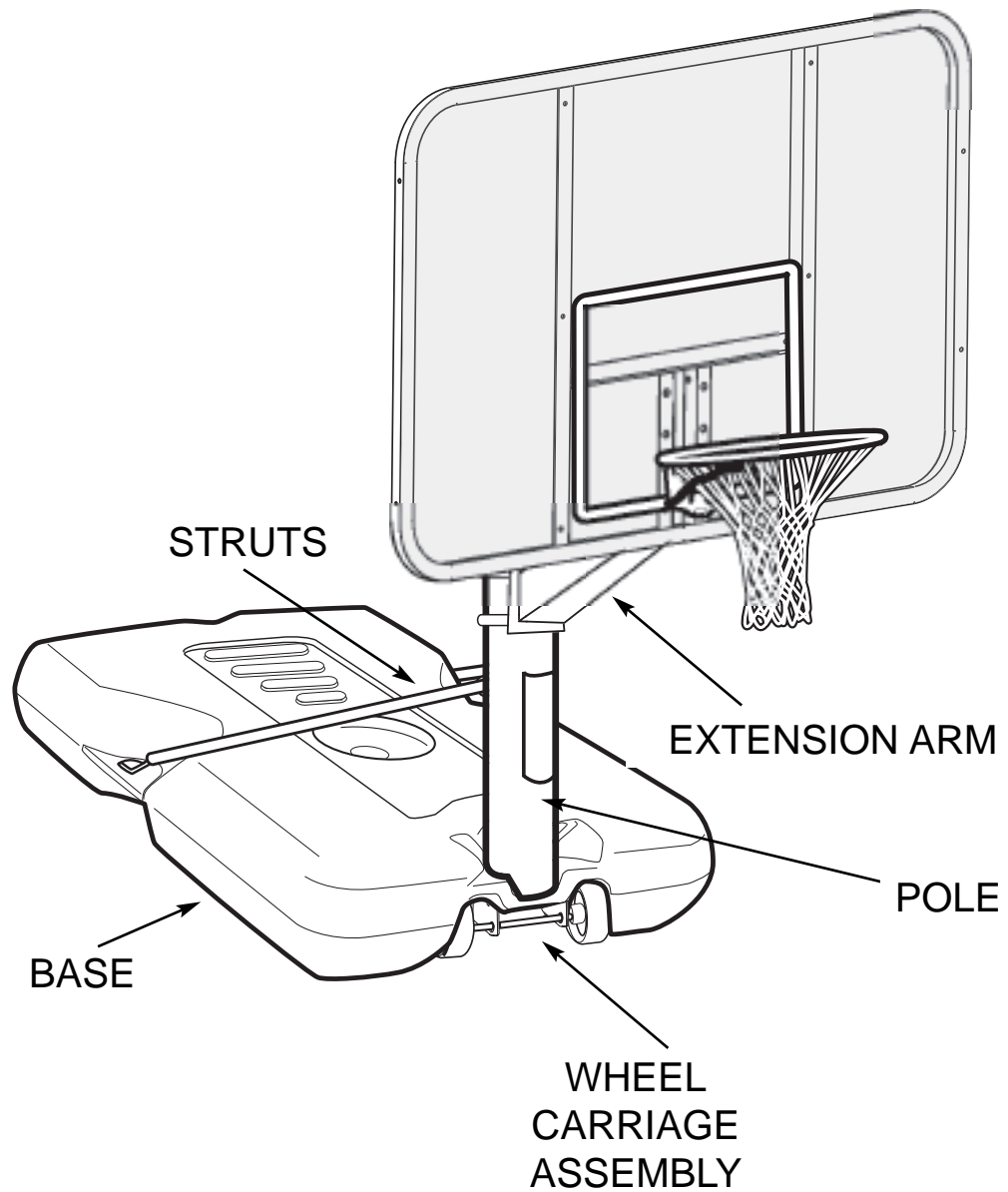

# **WARNING**

## **FAILURE TO FOLLOW THESE WARNINGS MAY RESULT IN SERIOUS INJURY AND/OR PROPERTY DAMAGE.**

**Owner must ensure that all players know and follow these rules for safe operation of the system.**

- See instruction manual for proper installation and maintenance.
- **DO NOT** position system near trampolines, diving boards, slides or any play area equipment. System misuse could result in serious bodily injury.
- **DO NOT** perform dunk type activities on this system.
- **DO NOT** hang from any part of system, including backboard, support braces, rim or net.
- **DO NOT** jump, slide, climb, shake or play on tank and/or pole.
- Surface beneath the tank must be smooth and free of gravel or other sharp objects. Punctures cause leakage and could cause system to tip over.
- After assembly is complete, fill tank completely with water or sand and stake to ground and/or permanent solid object.
- Never leave system in an upright position without filling tank with weight, as system may tip over causing injury.
- **DO NOT** allow water in tank to freeze. During sub-freezing weather fill with 2 gallons of non-toxic antifreeze, sand or empty tank completely and store. (Do Not Use Salt.)
- Keep pole top covered with cap at all times.
- Keep organic material away from pole tank. Grass, litter, etc. could cause corrosion and/or deterioration.
- Check pole system for signs of corrosion (rust, pitting, chipping) and repaint with exterior enamel paint. If rust has penetrated through steel anywhere, replace pole immediately.
- Check system before each use for loose hardware, excessive wear and signs of corrosion and repair before using.
- Check system before each use for stability.
- **DO NOT** use system during windy and/or severe weather conditions, system may tip over. Place system in the storage position and/or in an area protected from the wind and free from personal property and/or overhead power lines.
- During play, use extreme caution to keep player's face away from the backboard, rim or net. Serious injury could occur if teeth/face come in contact with backboard, rim or net.
- When adjusting height or moving unit, keep hands and fingers away from moving parts. Do not allow children to adjust system.
- During play, do not wear jewelry (rings, watches, necklaces, etc.) Objects may entangle in net.

**HUFFY<sup>®</sup>SPORTS**  
A Division of Russell Corporation

In the U.S.: 1-800-558-5234 and Canada Only: 1-800-284-8339

211239 2/05

## PARTS LIST (See Hardware Identifier)

Item	Qty.	Part No.	Description	Item	Qty.	Part No.	Description
1	1	206740	Tank (White)	18	1	902006	Extension Arm, White
2	1	200628	Wheel Axle	19	8*	203309	Washer, 1 O.D.
3	2	226401	Wheel	20	4	203104	Bolt, Hex Flange, 5/16-18 x 2 Long
4	1	908121	Bottom Pole Section	21	2	200837	Spacer, Plastic
5	1	202820	Rod, 3/8 O.D. x 4-3/4 Long	22	2	201562	U-bolt, Round, 3/8-16 x 2-3/4 Long
6	1	202822	Eye Bolt, 3/8-16 x 3-3/4 Long	23	1		Net
7	1	200627	Wheel Bracket	24	1	201190	Cap
8	5	203063	Lock Nut, Nylon Insert, 3/8-16	25	1	203124	Tie Down Stake
9	1	201625	Bolt, Hex Head, Yellow Dichromate, 5/16-18 x 3.60" Long	26	2	201651	Spacer, Wheel Axle
10	6*	203218	Washer, 5/16 Flat	27	1	201568	T-Strap
11	2	986206	Tank Strut	28	1	201189	Tank Cap
12	1	203220	Lock Nut, 5/16-18	29	4	200516	Bolt Covers, Black Vinyl
13	1	201261	Label, Moving System				
14	2	203156	Bolt, Hex Head, 5/16-18 x 1 Long				
15	6*	203100	Nut, Hex Flange 5/16-18				
16	1		Rim				
17	12*	201219	Clip, Net Holder				

\* You may have extra parts with this model.  
 \* Units with 42" steel frame acrylic backboard do not require the use of included board struts (.75" x 22")

### HARDWARE IDENTIFIER (BOLTS & NUTS)

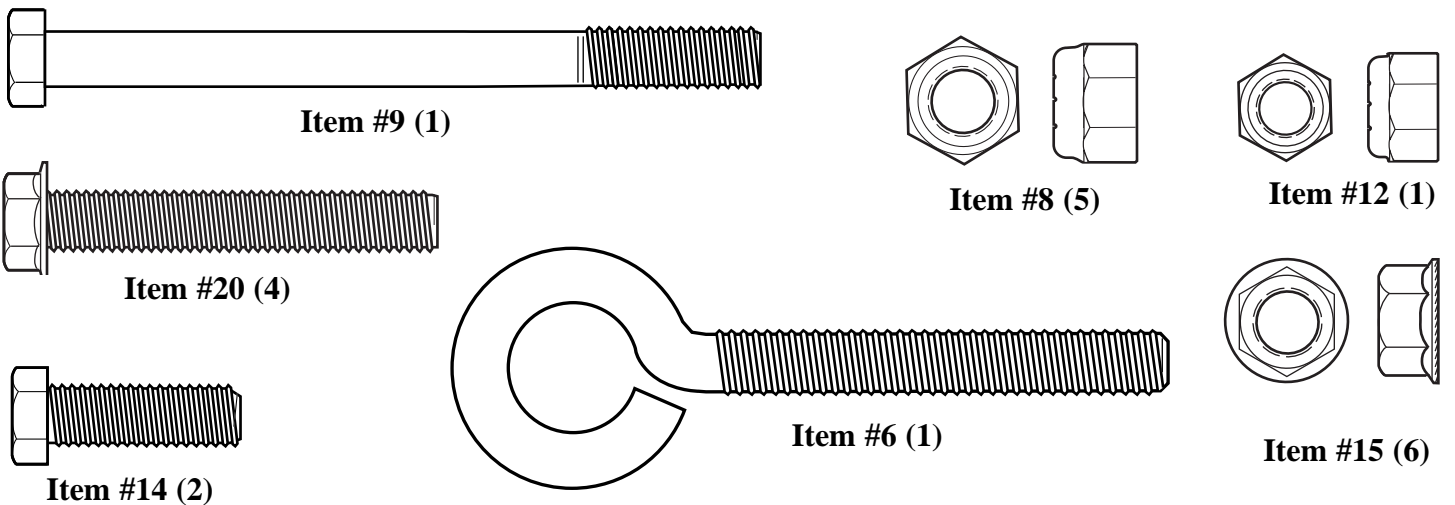

### HARDWARE IDENTIFIER (OTHER)

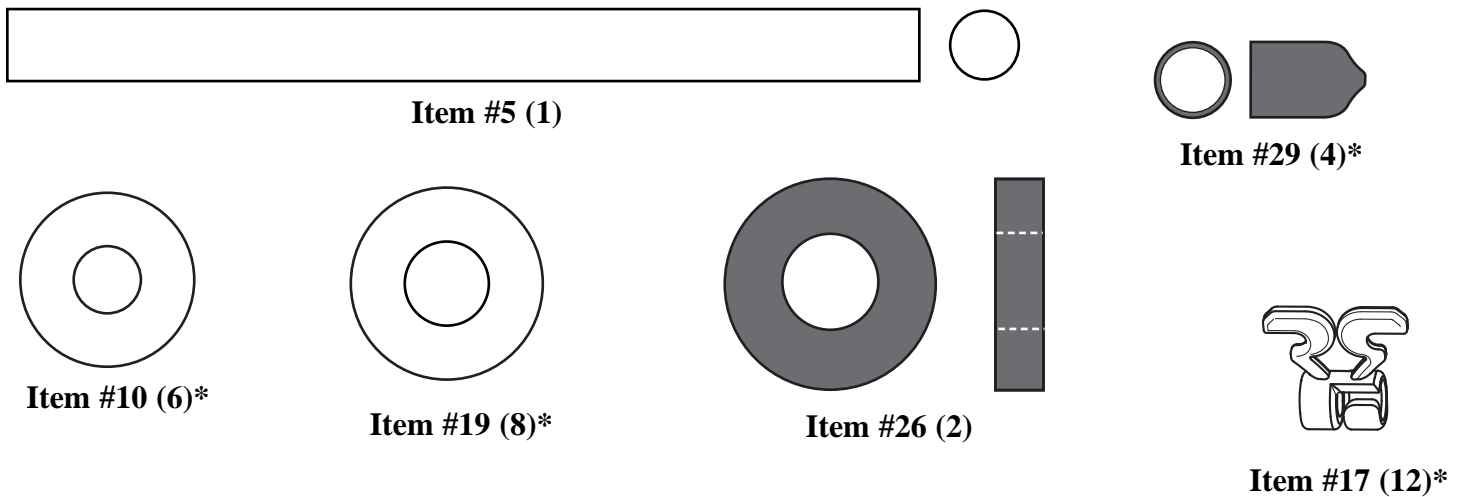

# SECTION A: ASSEMBLE THE BASE

This is what your system will look like when you've finished this section:

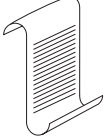

**NOTE:**  
\* Units with 42" steel frame acrylic backboard do not require the use of included board struts (.75" x 22")

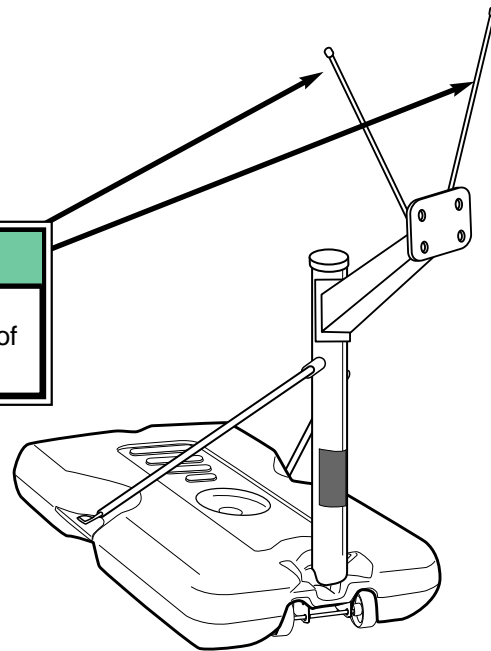

## TOOLS REQUIRED FOR THIS SECTION

**9/16" and 1/2"**

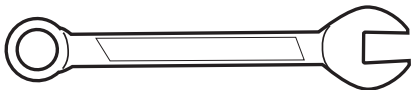

**AND/OR**

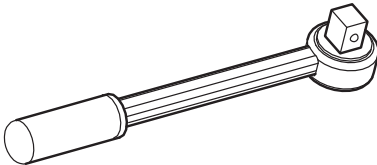

**9/16" and 1/2"**

## HARDWARE USED IN THIS SECTION (not actual size)

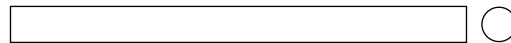

**Item #5**

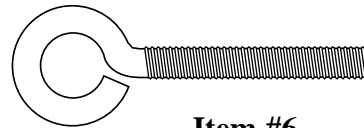

**Item #6**

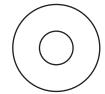

**Item #10**

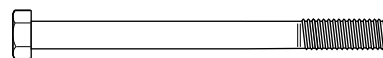

**Item #9**



**Item #15**



**Item #14**



**Item #26**



**Item #12**



**Item #8**

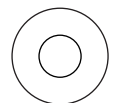

**Item #19**

**1.** Remove contents from tank

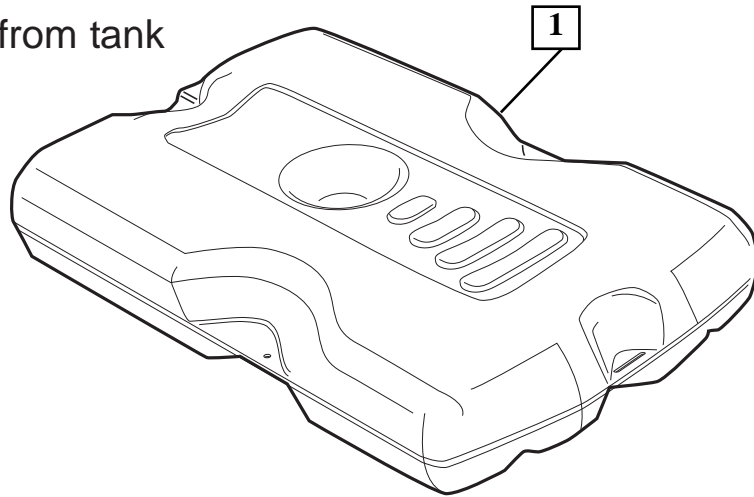

**2.** Install rod (5) through holes in bottom pole section (4) and eyebolt (6).

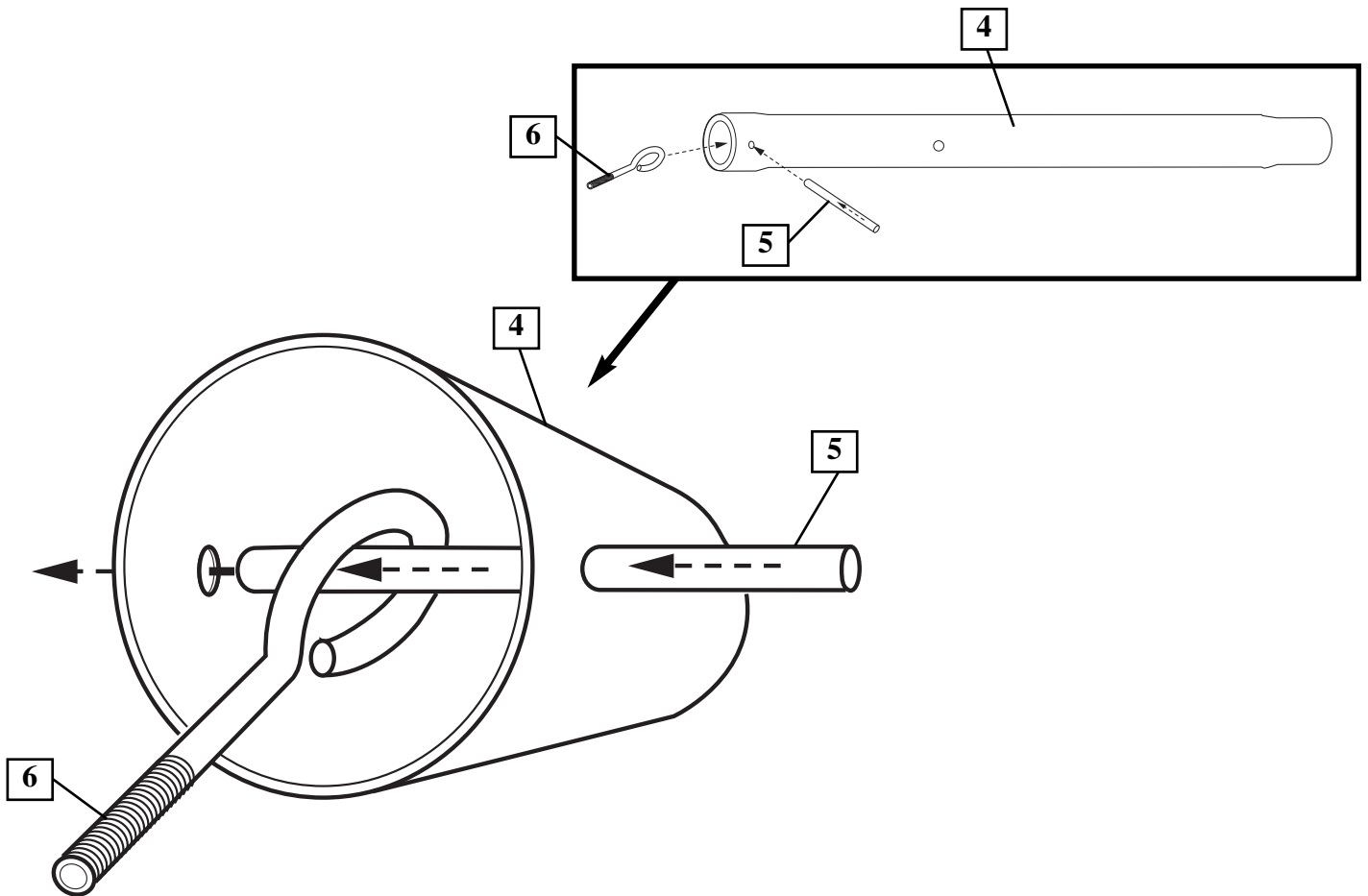



- 3.** Install wheel axle (2) through wheel carriage (7) and install wheels (3) onto wheel axle (2) with spacers (26) as shown. Insert pole assembly into tank assembly as shown. Secure bottom pole (4) to tank and wheel bracket as shown, a deep socket is recommended. **IMPORTANT! DO NOT OVER TIGHTEN.**

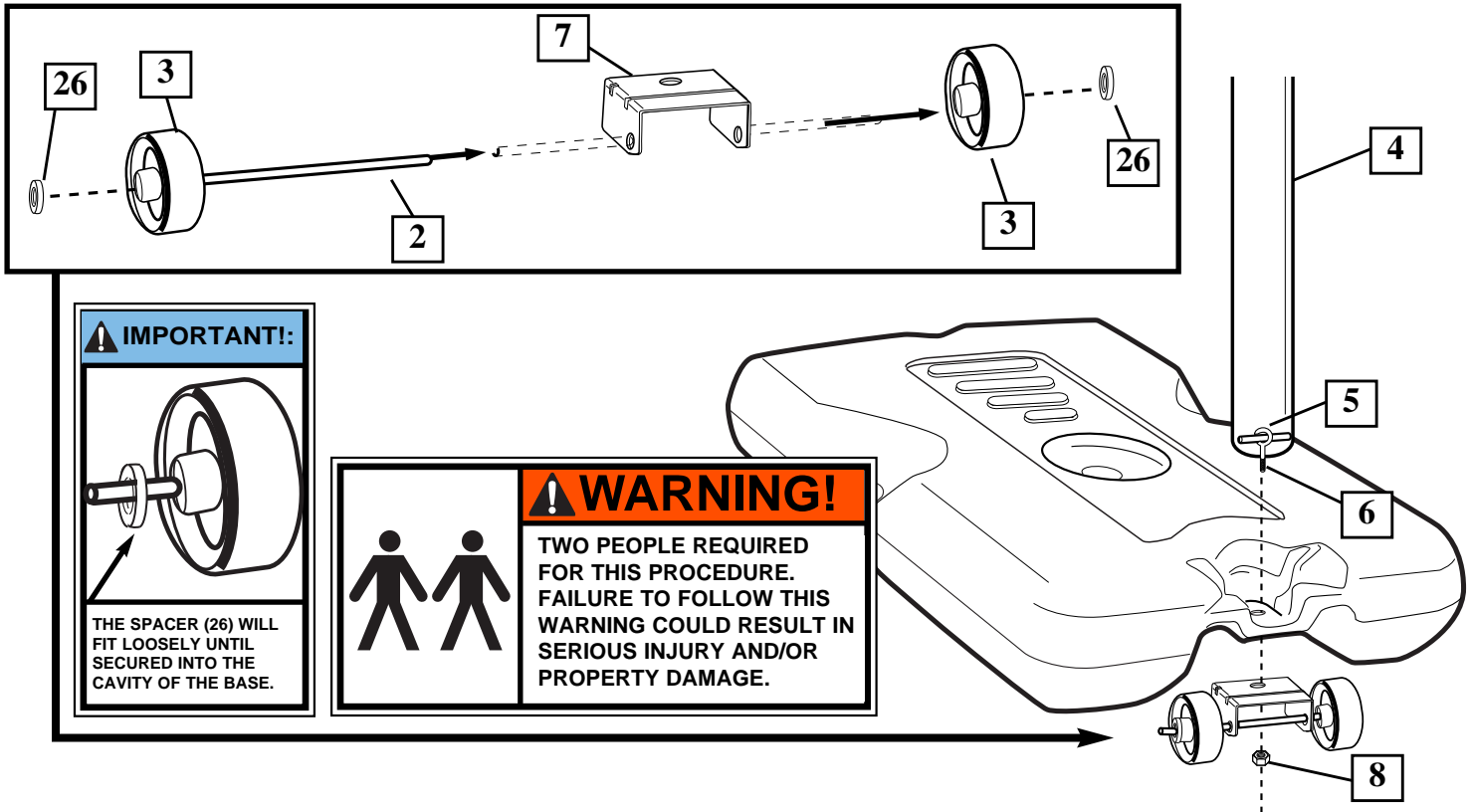

- 4.** Secure tank struts (11) to pole. Rotate non-secured ends of tank struts (11) outward to mounting holes in tank as shown.

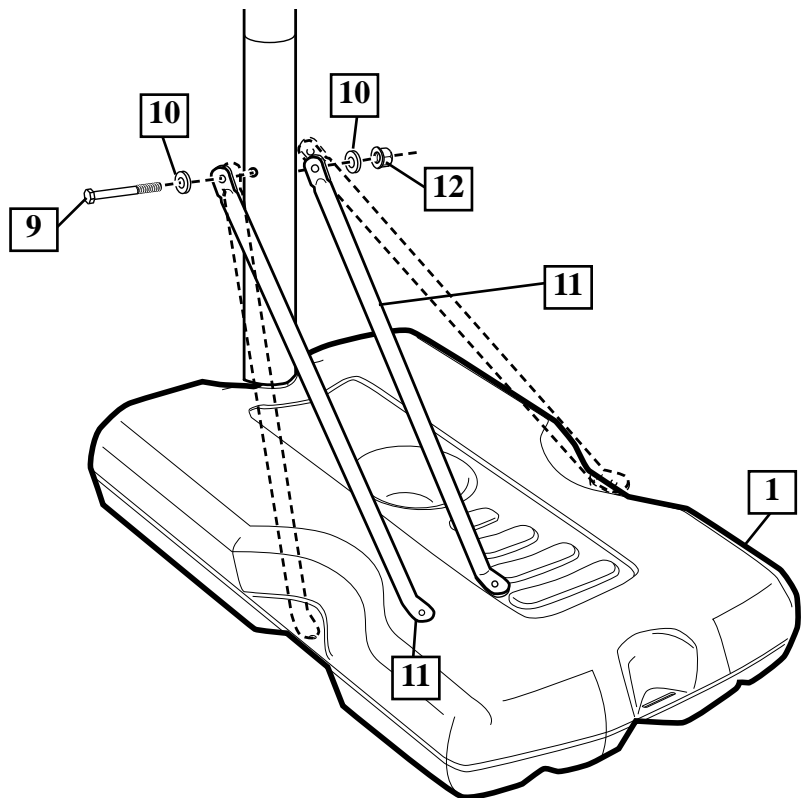
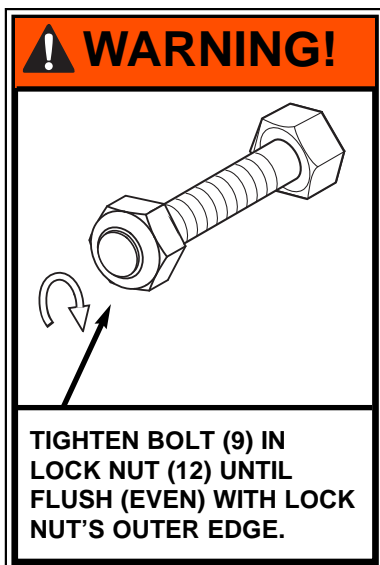

5. Secure non-secured ends of tank struts (11) to tank as shown. Repeat for opposite side.

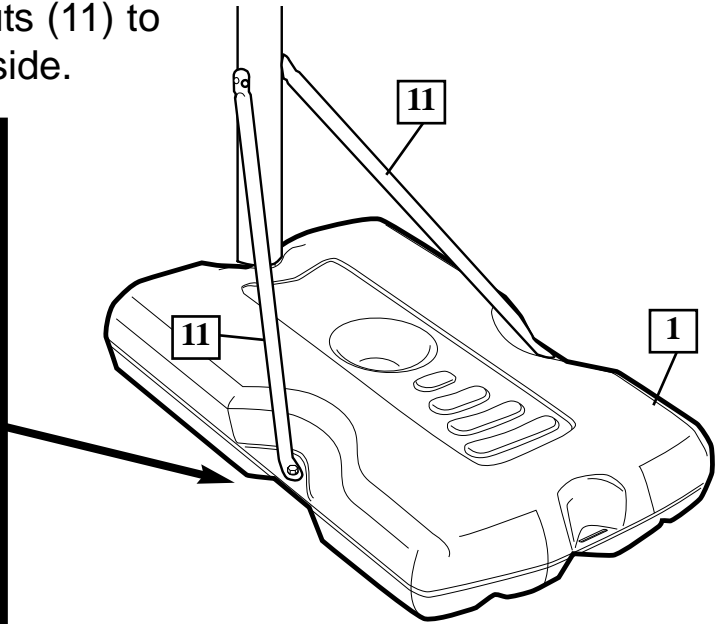
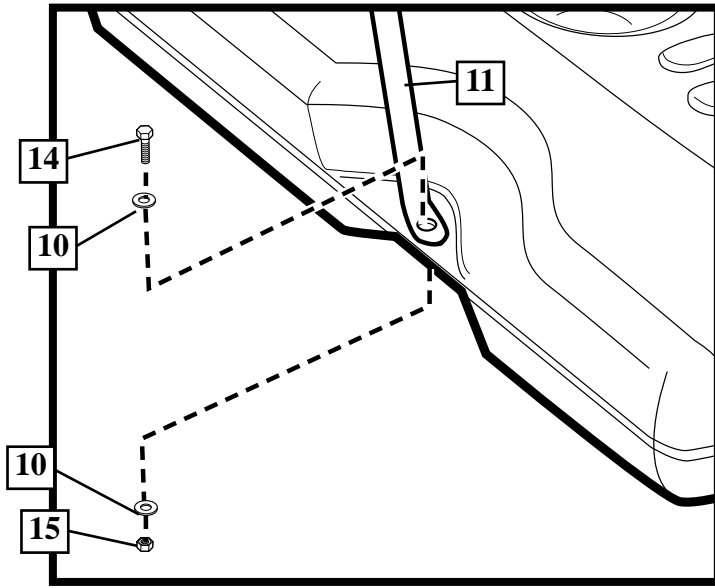

6. Attach extension arm (18) to pole using U-bolt (22), washers (19), nuts (8), as shown. Install pole cap (24) as shown.

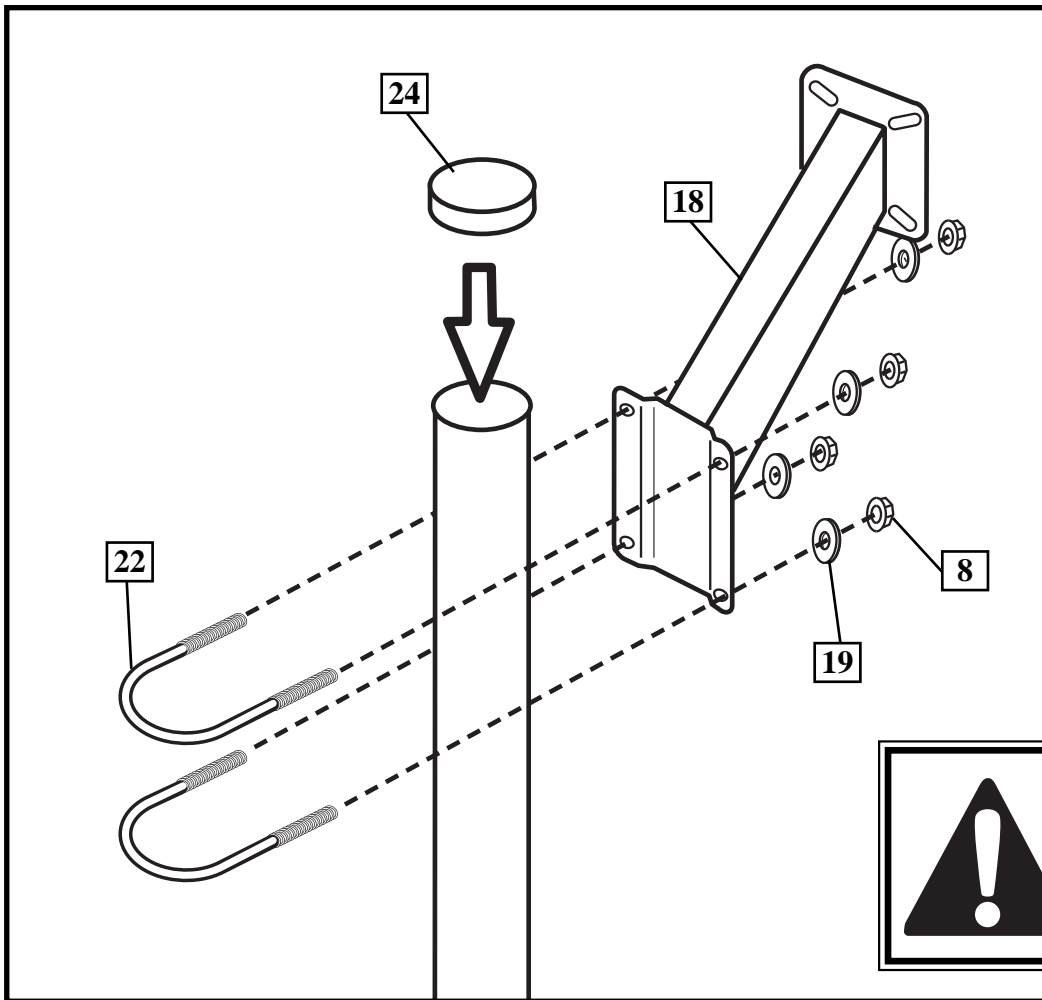

# SECTION B: ASSEMBLE THE BACKBOARD

This is what your system will look like when you've finished this section:

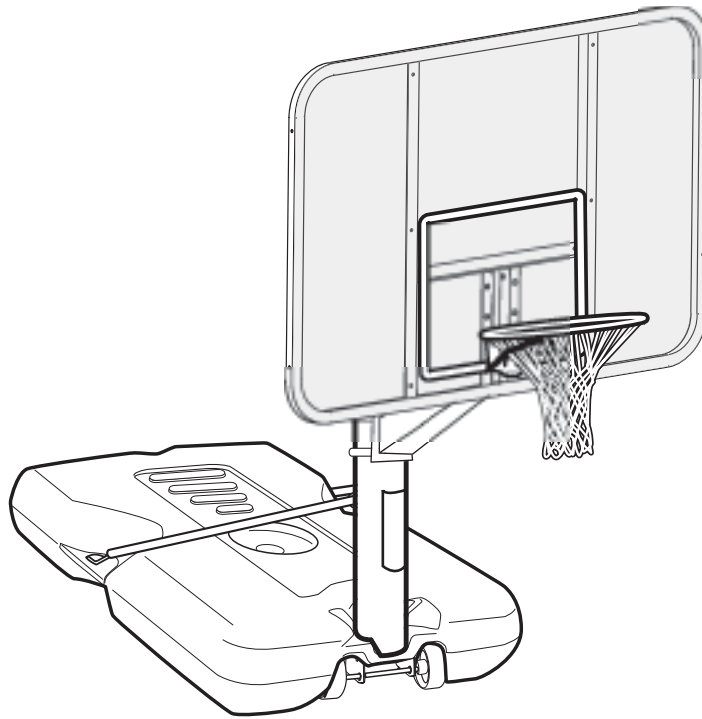

## TOOLS REQUIRED FOR THIS SECTION

1/2"

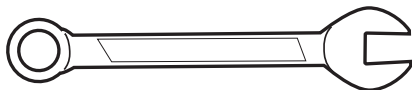

OR

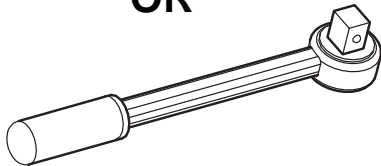

1/2"

## HARDWARE USED IN THIS SECTION

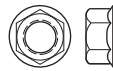

Item #15



Item #17



Item #20

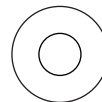

Item #19



Item #29

**7.** Install backboard assembly to the pole assembly as shown. Attach backboard and rim (16) to the extension arm (18) using bolts (20), spacers (21), washers (10, 19) and nuts (15) as shown. Tighten completely. Attach bolt covers (29).



**! WARNING!**  
TWO PEOPLE REQUIRED FOR THIS PROCEDURE. FAILURE TO FOLLOW THIS WARNING COULD RESULT IN SERIOUS INJURY AND/OR PROPERTY DAMAGE.

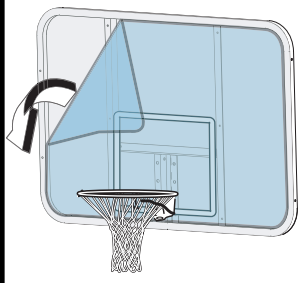

**NOTE:**  
Peel protective film from surface of acrylic backboard prior to use.

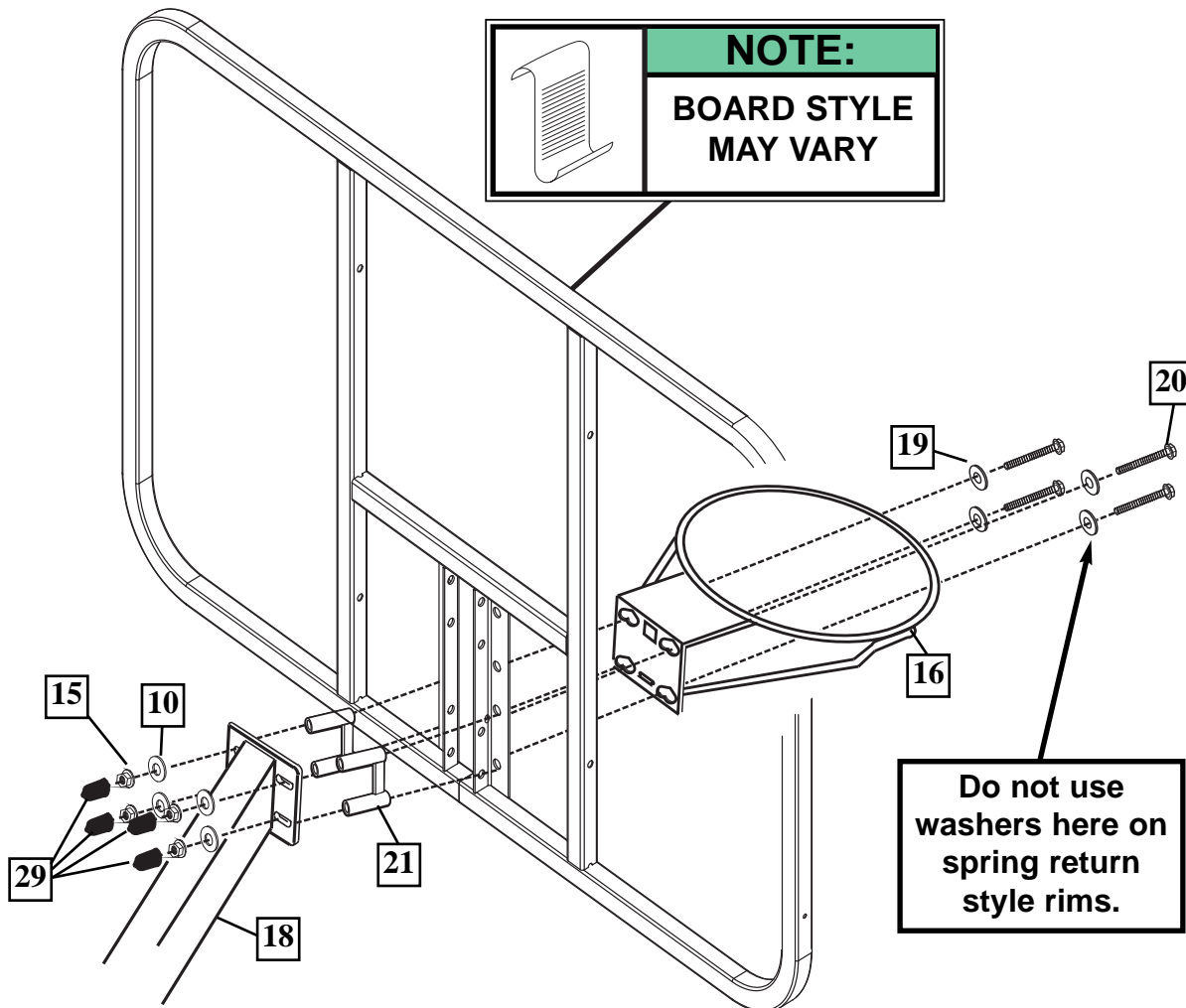

**8.** Install net clips.

**! WARNING:** Use of this product without proper installation of net clips, or when all net clips are not present could result in bodily harm. Be sure to follow directions carefully.

	<b>! WARNING!</b>
	USE OF THIS PRODUCT WITHOUT PROPER INSTALLATION OF SMART CLIPS®, OR WHEN ALL SMART CLIPS® ARE NOT PRESENT COULD RESULT IN BODILY HARM. BE SURE TO FOLLOW DIRECTIONS CAREFULLY.

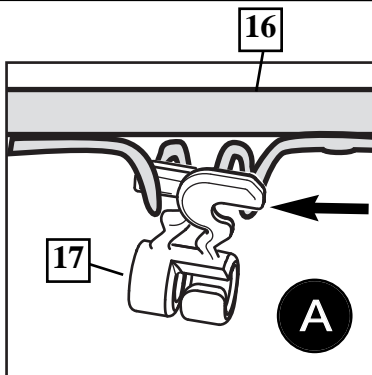
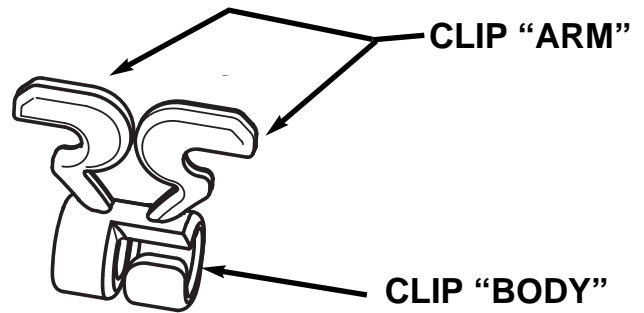

Insert one "arm" of clip into ram as shown. Twist "body" of clip slightly so that second "arm" slides over the top of the first "arm" as shown. Push in the direction indicated by arrow.

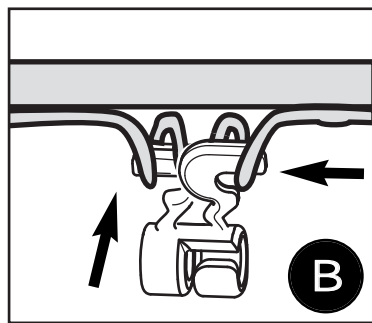

Push second "arm" back and into ram as shown.

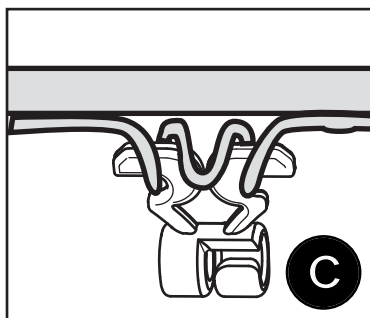

Twist "body" of clip slightly again to spread "arms" of clip. Clip "arms" must be flat and touching edge to edge as shown, not overlapping.

# NET INSTALLATION

9.

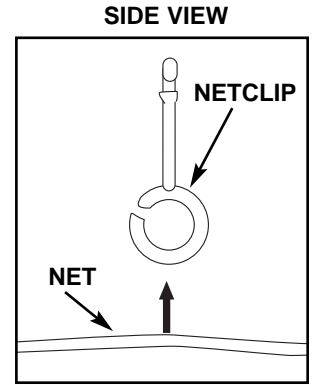
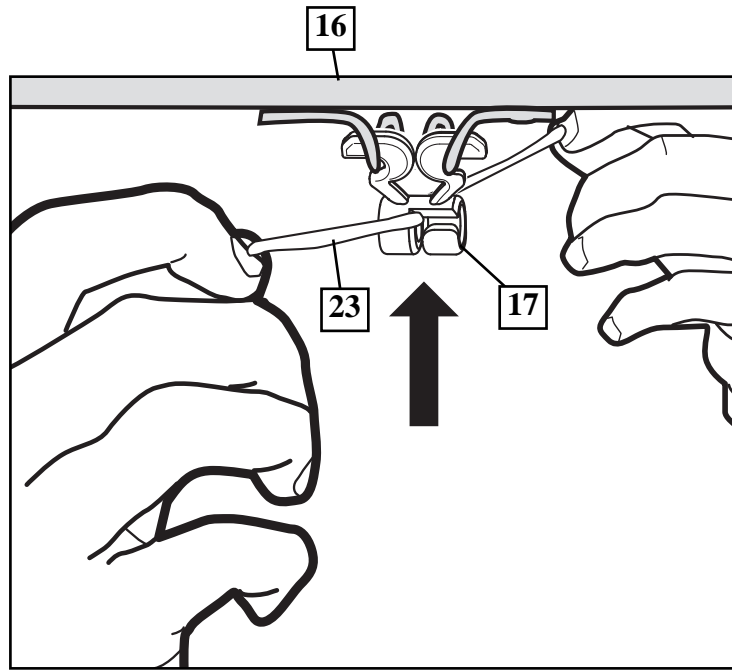

Insert net into bottom of clip as shown.

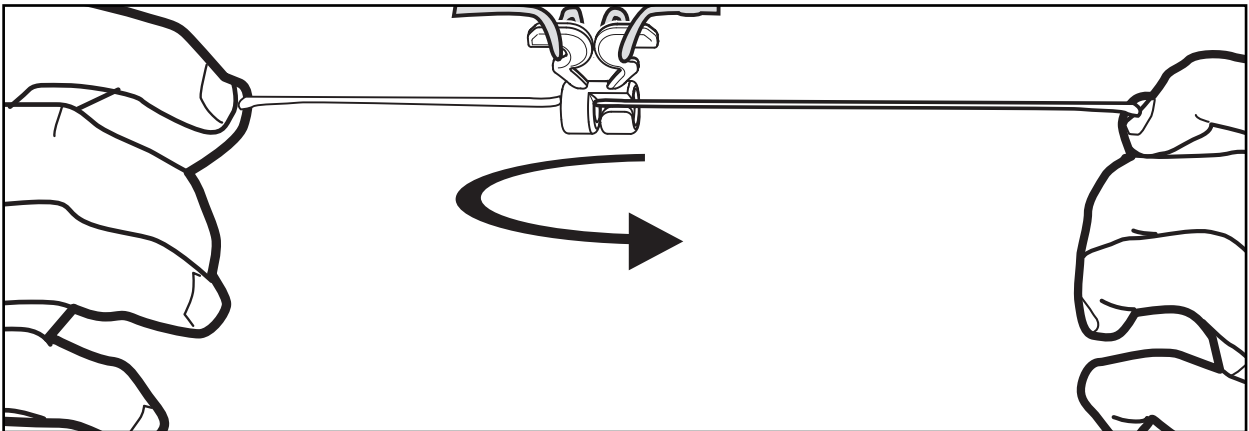

Twist net until it snaps into position.  
Net must be centered through clip.

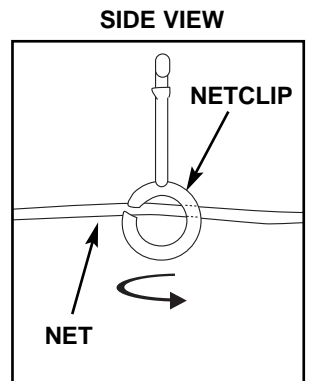

## SECTION B: SECURING THE SYSTEM

1. Place assembled unit to desired location. Fill tank with water (30 gallons/114 liters) or sand (360 lb./163 kg) and snap tank cap (28) in place. Insert T-strap (27) through slot on back of base as shown. Secure unit to ground by twisting tie down stake (25) into ground and hooking T-strap (27) onto tie down stake (25).

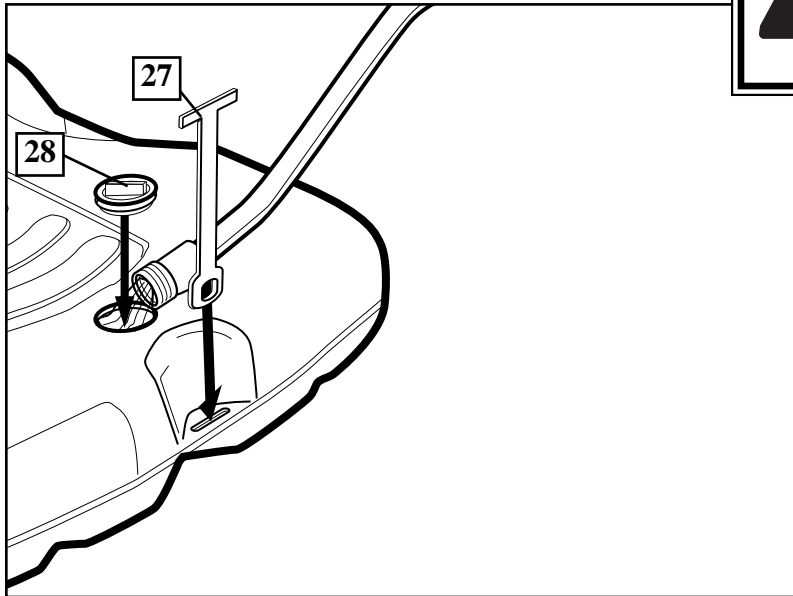

	<b>CAUTION!</b>
	ADD TWO GALLONS (7.6 LITERS) OF NON-TOXIC ANTIFREEZE IN SUB-FREEZING CLIMATES.

	<b>NOTE:</b>
	<b>IF USING SAND:</b> 2 GALLONS OF ANTI-FREEZE IS NOT REQUIRED

	<b>WARNING!</b>
	TWO PEOPLE REQUIRED FOR THIS PROCEDURE. FAILURE TO FOLLOW THIS WARNING COULD RESULT IN SERIOUS INJURY AND/OR PROPERTY DAMAGE.

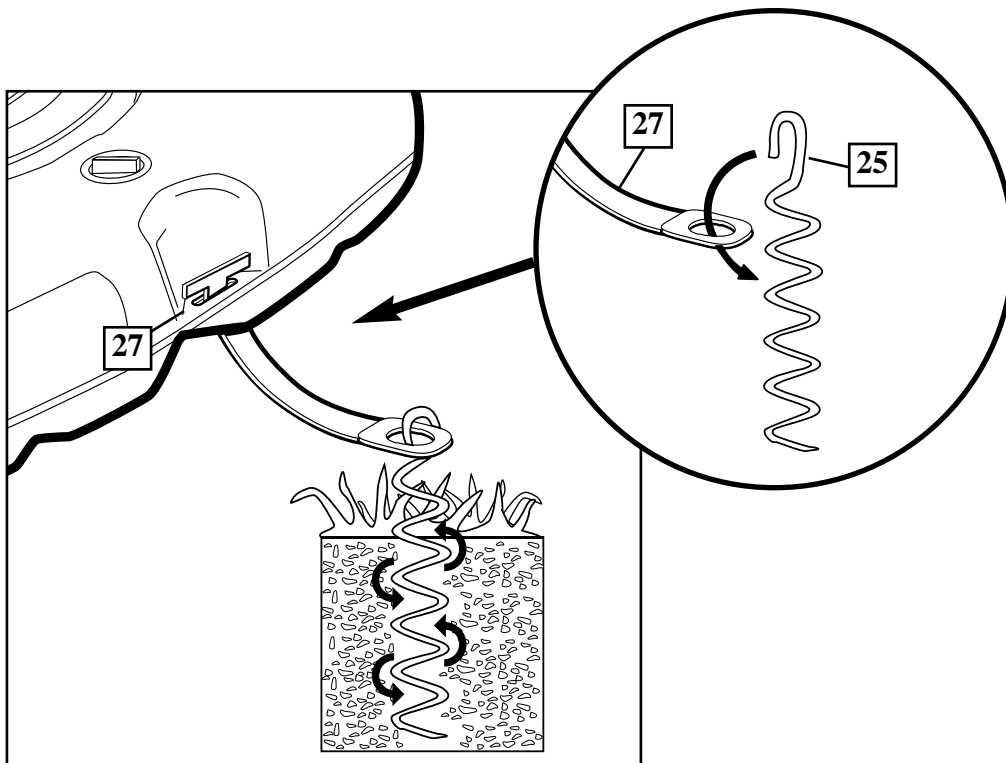

# SECTION C: APPLY HEIGHT AND MOVING LABEL

1. Apply Height and Moving label on pole as shown.

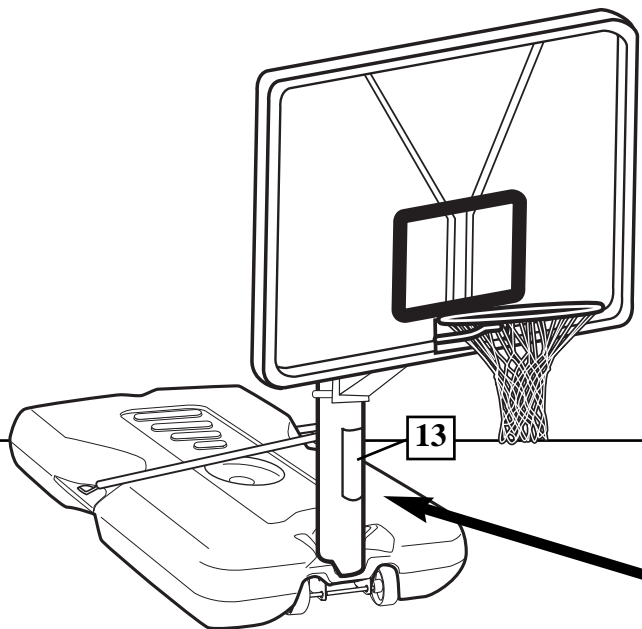

13

## MOVING SYSTEM

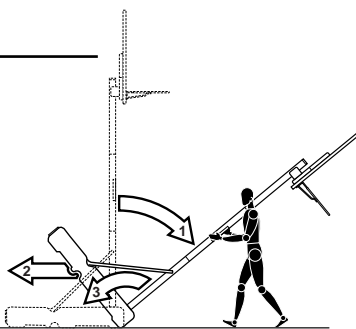

1. While holding pole, rotate basketball system forward until wheels engage with ground.
2. Move basketball system to desired location.
3. Carefully rotate basketball system upright.
4. Reattach ground restraint and check system for stability.

201261 3/99



## Free Manuals Download Website

<http://myh66.com>

<http://usermanuals.us>

<http://www.somanuals.com>

<http://www.4manuals.cc>

<http://www.manual-lib.com>

<http://www.404manual.com>

<http://www.luxmanual.com>

<http://aubethermostatmanual.com>

Golf course search by state

<http://golfingnear.com>

Email search by domain

<http://emailbydomain.com>

Auto manuals search

<http://auto.somanuals.com>

TV manuals search

<http://tv.somanuals.com>