

# TCR10-10



## OPERATIONS MANUAL



## TRANSDUCER MOUNTING PROCEDURE

Humminbird's high-speed transducer is supplied with your LCR. This transducer has been designed to give good high speed readings on most all boat designs, including aluminum.

Please carefully consider the following before installing your transducer.

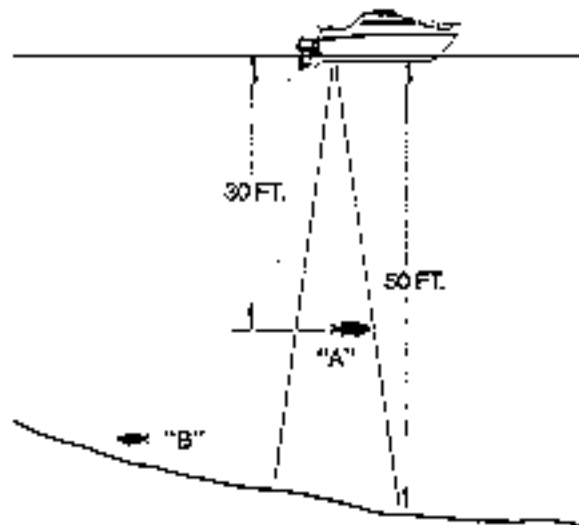
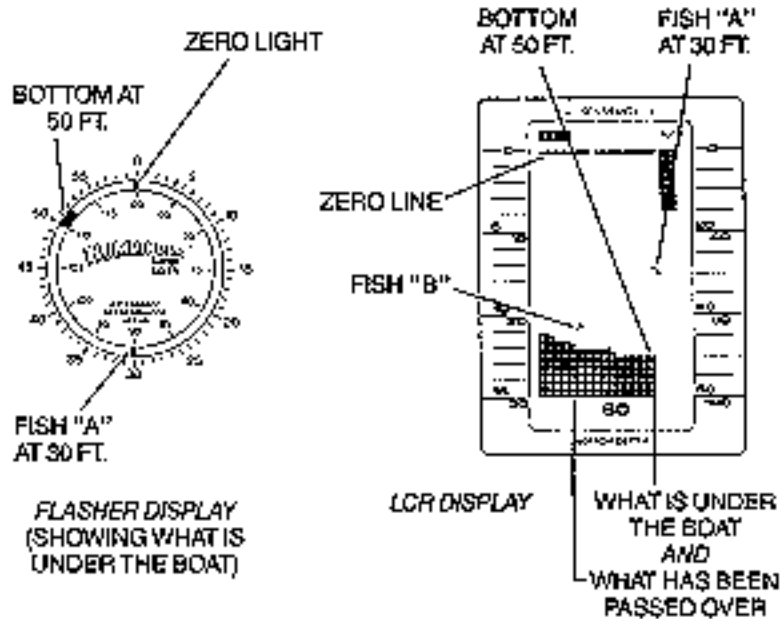

FIGURE 1

## TRANSDUCER MOUNTING OPTIONS

- A. Transom Mount- The Humminbird high speed transducer allows the transducer element to be mounted below the bottom of the boat hull keeping the transducer out of turbulent water and insuring good high speed operation. The transducer will absorb the blow of any obstruction

by rotating up out of the metal spring bracket without harming the transducer, or your boat. The transducer can be re-engaged by simply rotating the transducer down and snapping it back in place. (See Figure A)

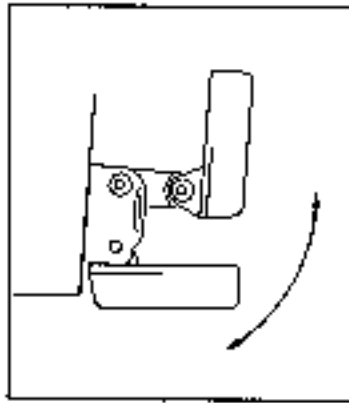

Figure A

- B. Inside Hull Mount- The high speed transducer can be mounted inside the hull (without pivot assembly) using the proper two-part epoxy, such as Humminbird's epoxy kit. Even though there is some loss of signal in shooting through the hull, your LCR will perform well with this type of installation. You cannot shoot through the hull of an aluminum boat.
- C. Trolling motor Mount- This type of transducer is not supplied with your LCR. It is designed to mount on the foot of a trolling motor. You may exchange your un-used high speed transducer for a trolling motor transducer. Call the Humminbird Customer Service Department.
- D. Bronz Thru-Hull Mount- This transducer is not supplied with your LCR but for an additional cost you may exchange your un-used high speed transducer for a bronz thru-hull. The bronz thru-hull transducer has a threaded stem which installs through a hole drilled in the boat hull, leaving the housing exposed under the boat. This type of installation must be used for many boats with in-board engines, because there is no suitable location on the transom away from the noise and turbulence created by the prop. A bronz thru-hull transducer should be installed by qualified personnel only.  
The LCR will operate well at high speeds with a properly mounted transducer. Remember, a transducer will not work transmitting through air or through air bubbles.

## 1. TRANSOM MOUNTING PROCEDURE

### Step 1.

**MOUNTING LOCATION-** It is important that the transducer be mounted on the transom where water flow is in constant contact with the transducer. You may wish to observe the rear of the boat while it is moving through the water to determine the best mounting location.

### Step 2.

**BRACKET INSTALLATION (Aluminum Boats)-** To install the metal bracket on an aluminum boat locate the template on the transom between rows of rivets, or ribs that are on the bottom of the boat. Align the template so that the bottom corner of the template nearest the center of the transom is on the bottom edge of the transom.

Figure B

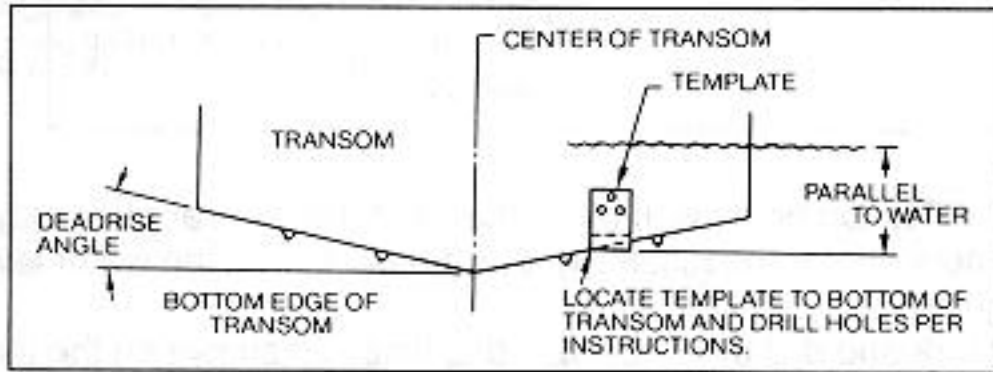

Once the location is determined mark and drill three 7/64" dia.. holes noted on the template. Attach the metal bracket using three #10 self threading screws supplied. Be sure to align holes in the center of the Bracket slots. On some aluminum boats it may be necessary to use a wood back-up plate. It is important to use a silicone sealant between the screwhead and bracket in order to prevent leaking. (See Figure C)

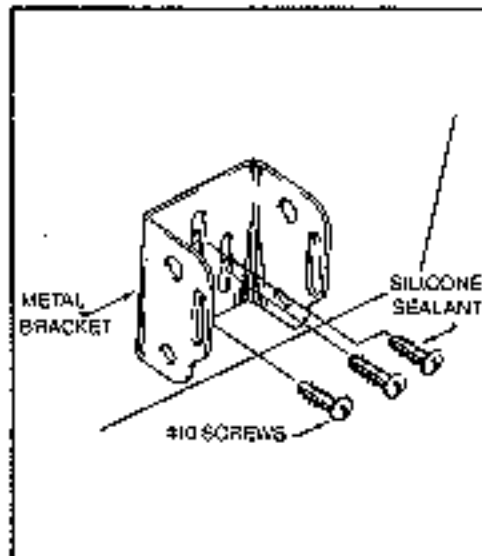
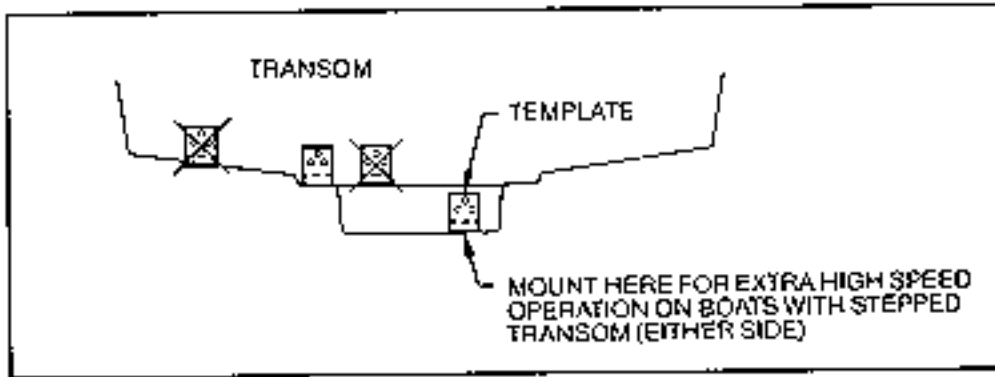

Figure C

Step 2.  
BRACKET INSTALLATION (Fiberglass Boats)- If your boat has a stepped transom located below and under the main transom, the compact transducer design allows mounting in this area. This mounting location is recommended for good reading at very high speeds. (See Figure D)

To install the metal bracket on a fiberglass boat, locate the template on the transom in the same manner as for an aluminum boat. (See Figure C)

Figure D



NOTE: On boats with more than 15 degree deadrise angle it may be necessary to mount the transducer slightly off parallel with the water level. (See Figure E)

Mark and drill the three 9/64" dia. holes as shown on the template. Attach the metal bracket using the three #10 self threading screws supplied. Be sure to align the holes so that they are centered vertically in the three slots found in the bracket. It is important to use a silicone sealant between the screwhead and bracket in order to prevent leaking.

Figure E

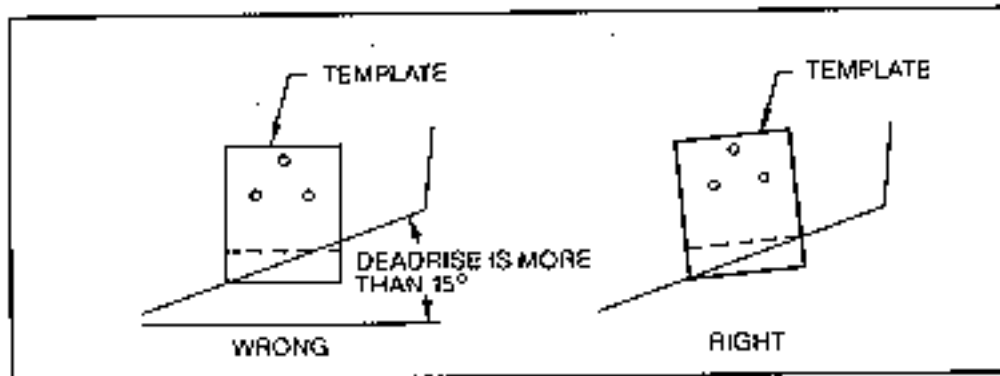

Step 3.

**TRANSDUCER PIVOT ASSEMBLY**- Assemble the pivot to the transducer main body using the two 1/4"x5/8" allen head screws, two 3/8" tooth washers and two, 1/4" square nuts. Make sure the tooth washers are sandwiched between the transducer main body and the pivot. The square nuts are trapped inside the pivot and will not rotate as the allen head screws are tightened. **HOWEVER, DO NOT TIGHTEN AT THIS POINT.** (See Figure F)

**CAUTION: DO NOT APPLY LOCTITE® OR SIMILAR LOCKING COMPOUNDS BECAUSE THEY WILL ATTACK THE PLASTIC.**

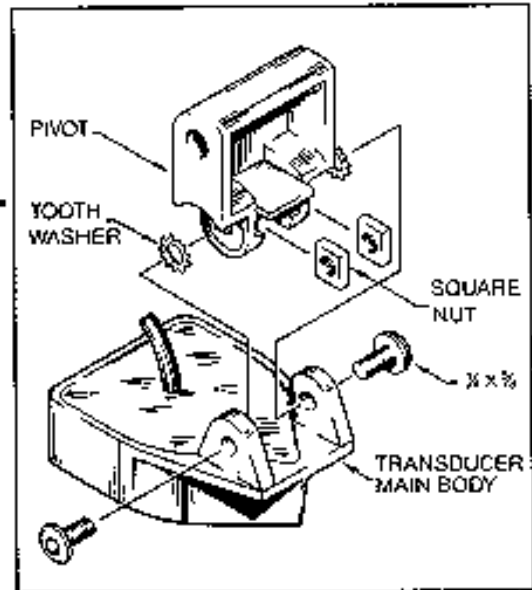

Figure F

Step 4

TRANSDUCER ASSEMBLY- Insert the transducer assembly into the metal bracket from the bottom. Push up until the holes in the plastic pivot align with the uppermost holes in the bracket. Slide the O-ring on to the headed pin and insert it through the two parts. Assemble by screwing the 1/4"x3/8" allen head screw into the end of the pin and tighten. (See Figure G)

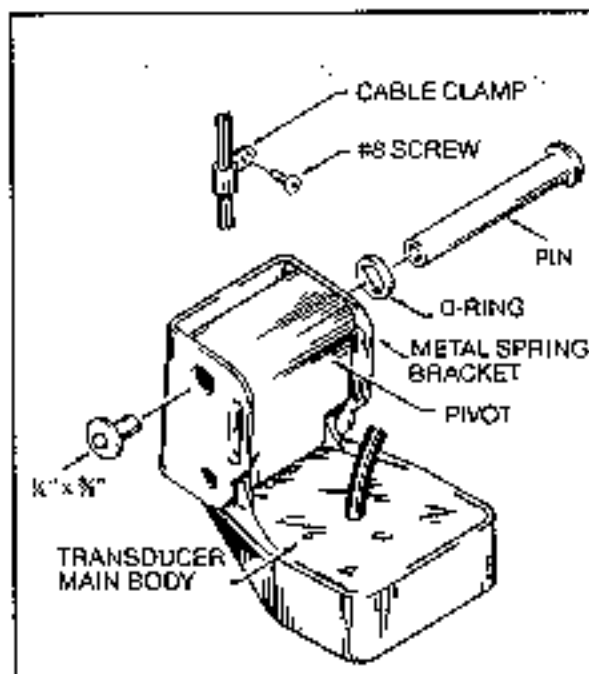

Figure G

Step 5

ANGLE ALLIGHMENT- Set the transducer angle so that it is parallel with the bottom of the boat hull. Once proper alignment is achieved, tighten the two allen head screws using the 5/32" allen

wrench provided. The screws are visible through the access holes on each side of the metal bracket. Check to make sure the transducer main body is rigidly fastened to the pivot. (See Figure H)

Figure H

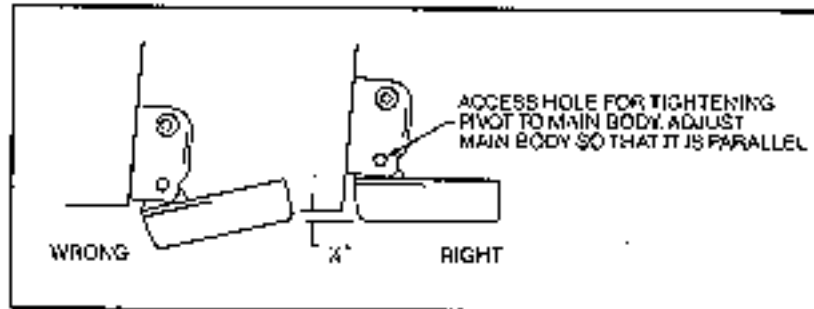

#### Step 6

**CHECK POSITION OF TRANSDUCER-** At this point, check to see that the bottom of the transducer is a minimum of  $\frac{1}{4}$ " below the bottom of the transom. (However, as noted in STEP 2, the top of the transducer cannot fall below the bottom of the transom). If it is not, remove the transducer assembly from the metal bracket by removing the pin installed during STEP 3. Loosen the metal bracket mounting screws, re-position the bracket utilizing its slotted holes, tighten and re-assemble. It may be necessary to replace the silicone sealant after this adjustment is made.

**NOTE:** It may be necessary to make several high speed runs to adjust transducer either UP/DOWN or to re-adjust the angle to achieve optimum results.

#### Step 7

**CABLE CLAMPS-** Install cable clamps as necessary by drilling a  $\frac{1}{8}$ " dia. hole for the # 8 screw supplied.

## 2. INSIDE HULL MOUNTING PROCEDURE

**Warning:** In order to achieve proper results with this type installation, it is important that the transducer be mounted by someone familiar with the use of two part epoxy adhesives. For this reason, Techsonic Industries, Inc. will not be responsible for any damage due to the mounting of your transducer in this manner.

**NOTE:** An Epoxy Kit (Part N. EPK) is available from Humminbird. This Epoxy Kit has been formulated for Inside Hull Transducer Installation.

1. Select as flat an area as possible near the aft end and center of boat where the hull is thin and not double. If the bottom has a runner down the center of boat, select an area to one side of the runner, but as close to the runner as possible.
2. Clean the inside of the boat with lacquer thinner in the area transducer is to be mounted. Outside of boat in this area should also be cleaned. (Not with lacquer thinner).
3. Put approximately one inch of water in the bottom of the boat.
4. Put transducer in the water. The bottom of the transducer should be in a flat area and should be in good contact with the bottom of the boat.
5. Operate the LCR with the boat operating at high speed. The transducer may have to be moved in order to find an area where satisfactory operation is observed.
6. When an area is found that produces satisfactory operation, mark the location of the transducer.

7. Remove the water and transducer and clean the marked area and the bottom of the transducer thoroughly.
8. Using the Humminbird Epoxy Kit or equivalent, mix an ample amount of epoxy without causing it to bubble and pour it in the area the transducer is to be mounted. The puddle should be larger than the bottom of the transducer.
9. Coat the bottom of the transducer with epoxy, then put it in the center of the puddle and push down on the transducer while moving it around in a circular motion. This forces out any air bubbles that may be trapped between the bottom of the transducer and the hull of the boat.
10. Let epoxy cure then the transducer is ready to operate. No water is now required in the bottom of the boat and gas and oil that is spilled inside of the boat will not degrade performance as it will if the transducer is placed only in water.  
CAUTION: Do not use the silicone seal or any soft adhesive to bond the transducer to the hull. This will reduce the sensitivity of the unit.

### CAUTIONS

1. Occasionally the "eye" of your transducer may become dirty from storage or from contact with oils present in boats or marina environments. (Oil will cause the "eye" to lose the intimate contact with the water which is necessary for efficient operation.) The "eye" may be cleaned with liquid detergent.
2. Improper installation of the transducer can alter the efficiency and accuracy of the entire system.
3. If your boat or transducer is out of the water for a period of time, it may take a short period of time for the transducer to become thoroughly "wetted" when returned to the water. Also, re-entry may cause turbulence, which will create air bubbles in the "eye" of the transducer. The bubbles will disappear in a short time or can be removed by rubbing the transducer "eye" with your fingers while the transducer is in the water.
4. If your instrument should fail to function, be sure to check all the electrical connections before removing the transducer or calling a serviceman.
5. Inspect your transducer cable and make sure that it has not been cut or damaged to the point where it will affect the performance of the transducer. A slight nick or cut, exposing the outer cable, can be repaired by wrapping with electrical tape. A transducer can be damaged if the inner cable and outer cable are allowed to make contact. Such a problem can sometimes be corrected by properly splicing the coaxial cable. This should only be attempted by a qualified service technician.
6. If your LCR is not working properly and you suspect the problem might be in your transducer, we would recommend you borrow a unit from a friend and try it on your boat. If the symptoms are the same, you can almost be certain that the problem is in the transducer.

### INSTALLING THE LCR

The LCR should be mounted on a flat, solid surface for maximum stability. The low profile swivel mount has four holes drilled in the base. It is recommended that all four holes be used.

Position the swivel base and drill four ¼" diameter holes. Note: The LCR hole pattern is the same as for all Humminbird flasher units. Use hardware provided to mount this base to the boat.

Next place the gimbal bracket on the swivel base and attach with four small machine screws, provided.

Place the LCR in the gimbal mount and make certain the rubber washers provided are placed between the unit and the gimbal bracket. Important: Note which side of the gimbal faces forward. (Slots on gimbal bracket go towards rear). Also, rubber washer must be located between the unit and the gimbal bracket.



Install the mounting knobs and tighten snugly. The unit can now be swiveled and tilted to any desired position.

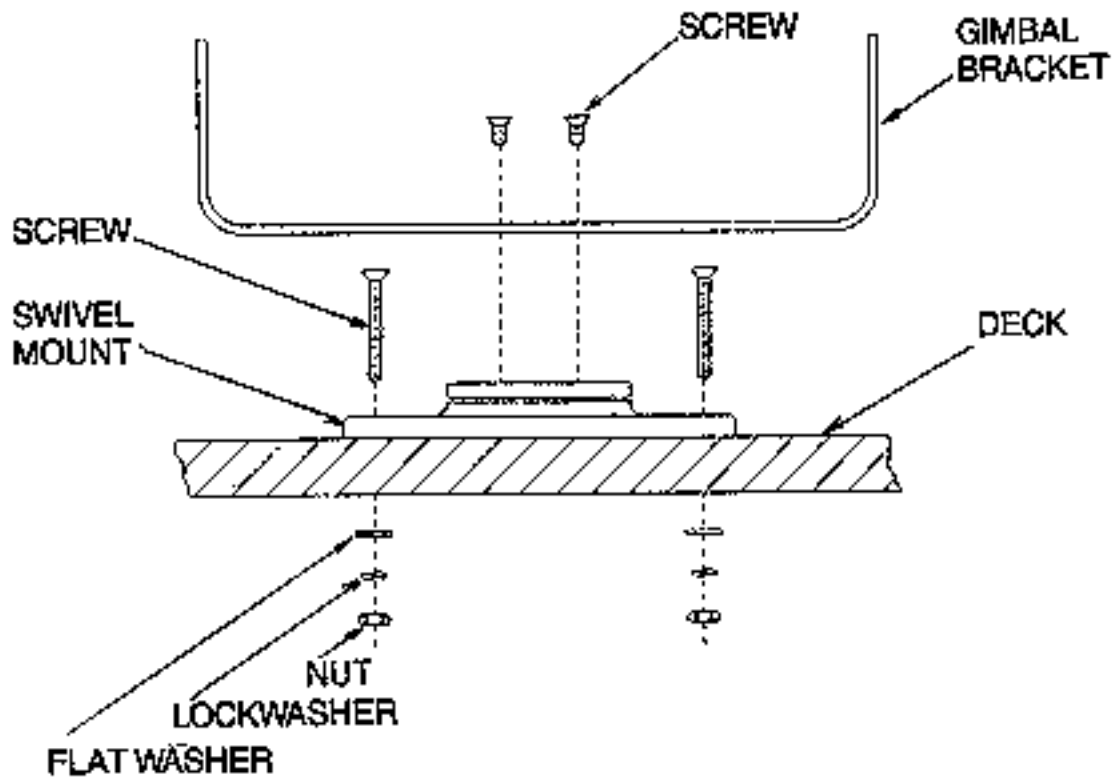
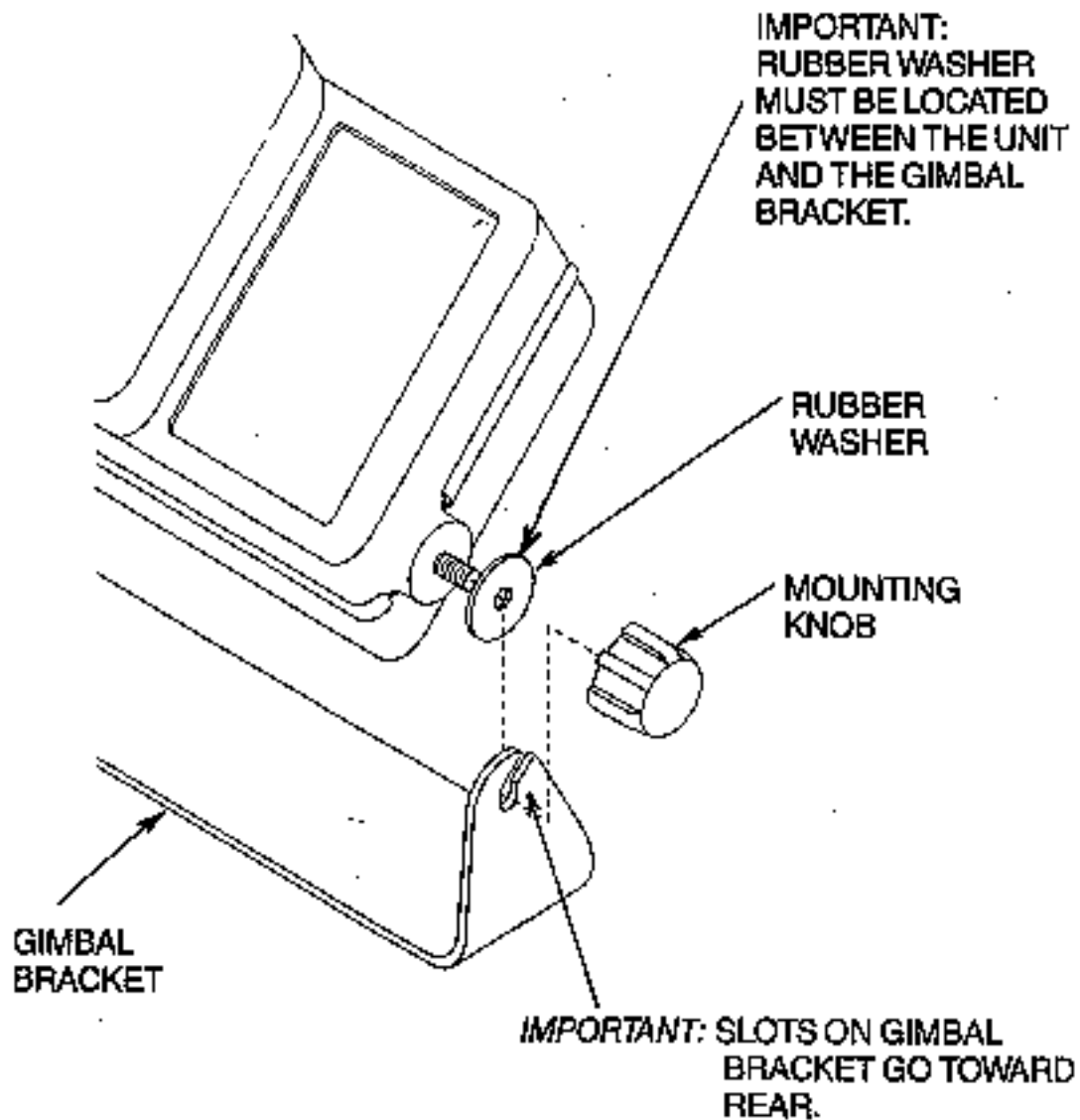

FIGURE 9



**FIGURE 10**

#### OTHER MOUNTING OPTIONS

1. The LCR gimbal bracket can also be mounted on the SM-4, quick disconnect swivel mount.
2. The LCR gimbal bracket can also be mounted directly to the dash without the swivel mount, however, this method is not recommended since the unit cannot be rotated.

#### INSTALLING THE CABLES

Your LCR comes equipped with Humminbird's new Angle-Lock power and transducer connectors. The power connector is identified with the letter P on the back of the plug.

It plugs into the outlet on the back of the unit marked "Power". The transducer connector is identified with the letter T and plugs into the outlet on the back of the unit marked "Transducer".  
Note: An adapter (AD-4) is available to allow use of an old waterproof (BNC) transducer with the LCR, but be sure that the transducer is a 16-degree. A 32-degree transducer cannot be used. A 1 1/8" hole must be drilled to pull through the transducer connector. After drilling the hole, pull the transducer connector up through the hole. If you are installing two units, both transducer connectors can be pulled through this 1 1/8" inch hole. Next, push the power cable wires down through the hole. A hole cover has been provided which will dress and hold the wires. Install the hole cover after determining the necessary wire length from the hole.  
The power cable has a red lead to the positive (+) post and the black lead to the negative (-) post. Install a 1 amp fuse between the red cable and positive post of your 12-volt battery.  
If a fuse panel is available, we recommend wiring the power cable into the fuse panel. Note: The LCR must be fused separately from any other accessory.  
Your Angle-Lock connectors can only be plugged in one way. Position the connector so the letter P or T can be read and the 90 degree bend is pointed downward. Push the connector in as far as it will go. Turn the positive locking ring as far as it will go clockwise until you feel it lock. Locking ring as far as it will go clockwise until you feel it lock. Your connector is now locked into place.  
Note: For easy access to the connectors, simply loosen the mounting knobs and tilt your LCR forward. The connectors are now in full view and easy to plug or unplug.

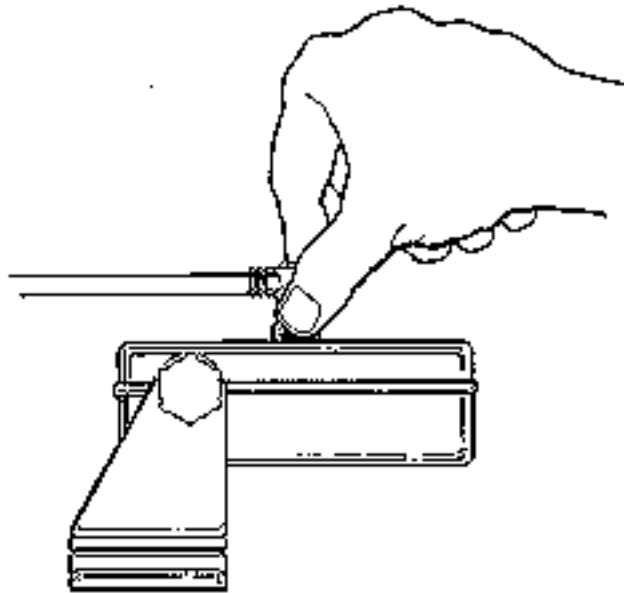

# TCRID-10

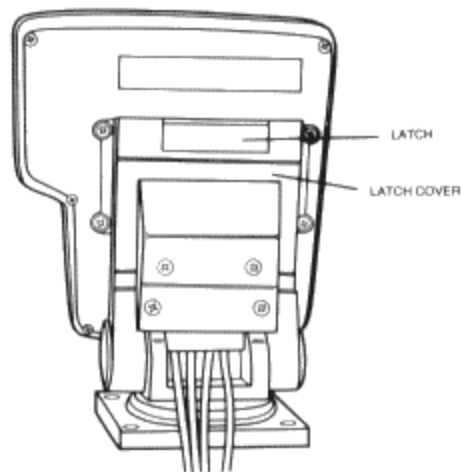
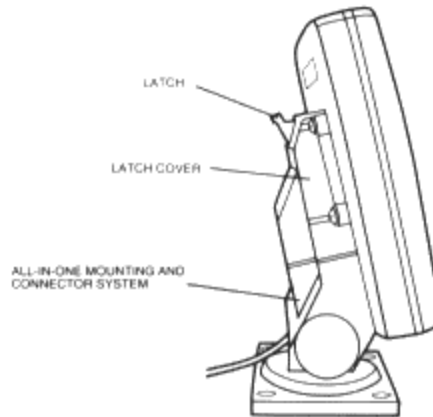
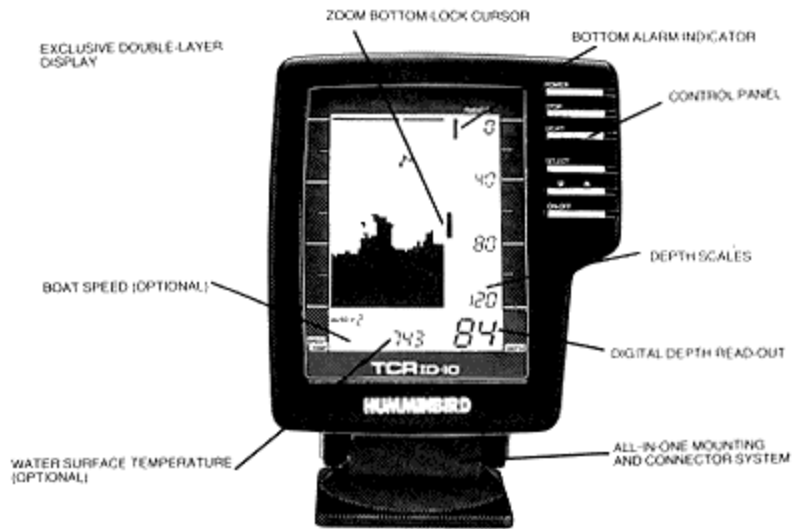

#### Specifications:

Operating Frequency	200 KHz
Power Requirement	12 volts
Power Cable Length	11 1/2'
Transducer (standard)	XHS-6-16 high-speed
Transducer Cone Angle	16 degrees
Transducer Cable Length	20'
Depth Ranges	0-15', 0-30', 0-60', 0-120', 0-180', 0-240', 0-360', 0-480'
Zoom Ranges	7', 15', 30'
Mounting (standard)	All-In-One Mounting & Connector System
Unit Construction	High-impact polycarbonate case
Dimensions	6 1/2"W x 6 3/4"H x 1 Y2"D
Display	liquid crystal
Viewing Area	3"W x 4" H
Matrix Configuration	48 x 75 pixels

#### TESTING THE INSTALLATION

Once you've installed your TCR ID-10, Transducer and cables, it's time to test the installation. This testing should be done on the water, since that is the only way to check your Transducer's performance.

##### Test Your TCR

With your boat at idle, turn the unit on. The TCR will perform a "self test" on its electronics to make sure everything is operating properly, and then it will select the right depth range and sensitivity level for the conditions. Momentarily, you'll see the reading start to "march" across the screen from right to left.

##### Test Your ID-10 Installation

Increase your boat speed to ensure that you get a continuous bottom reading as the boat moves. Your TCR ID-10 and its Transducer are designed to operate at up to 75 mph so feel free to test them at very high speeds.

If the TCR ID-10 performs well at idle or slow speeds, but the display is not continuous at higher speeds, then the Transducer is not installed properly. Air bubbles or turbulence from the boat hull are passing across the face of the Transducer, blocking the transmitted signal. Following the instructions in "Mounting The Transducer," you can make simple adjustments that should take care of the problem.

NOTE: Should problems occur during your tests, first consult the "Before You Call For Service" section in this manual for trouble-shooting tips from the Humminbird engineers. If you don't find the solution there, call our toll-free Customer Service Hotline listed on page 2.

#### BUILT-IN SIMULATOR

To help you learn to use your new unit, Humminbird has built a simulator into the TCR ID-10. The simulator will display a typical underwater scene, and allow you to use the controls for practice.

Activating the simulator is easy-with the unit turned off, hold down the power button for about 2 seconds, until a chirping sound begins. When you release the button, the built-in simulator will be on and ready for your practice session. Turning your unit off and back on again will disengage the simulator, for operating the TCR ID-10 in actual conditions.

NOTE: The built-in simulator will allow you to practice adjusting the sensitivity, but your adjustments will not change readings being displayed on the screen.

## READING THE TCR ID-10 SCREEN

Your TCR has a liquid crystal display, or LCD. The liquid crystal material in the display aligns itself to either block light or let light pass through. This blocking of light creates images on the screen. Since the display depends on light to form its images, increasing the light source makes it to see. This is why your TCR can be seen so well in bright, direct sunlight.

You will also notice that the display can be seen better at certain angles. The TCR mounting system has been designed for tilting and pivoting so that you can easily maintain a good angle for viewing. Another characteristic of the display is that some polarized glasses can affect your view by causing a rainbow or prism to appear. This can be improved by slightly tilting the unit.

### Fish Identification

The TCR ID-10 uses Humminbird's exclusive double-layer LCD. Ordinary LCD units have 2 colors-black and white. But the TCR ID-10 adds a third color-red-by using a second layer on the display. This double - layer display gives you more information than ordinary black and white units:

1. Objects not connected to the bottom are displayed in red. The bottom and any structure attached to it are displayed in black. The microcomputer within the TCR I-10 can separate objects from the bottom no matter what depth range you're in. This IS' especially helpful if you're bottom fishing.
2. Stronger signals are displayed as a black dot behind a red dot. The TCR ID-10's microcomputer also helps you identify stronger signals, such as those from larger fish, because they are displayed as a black dot behind a red dot. It's easy to separate them from the weaker returns displayed in red only.

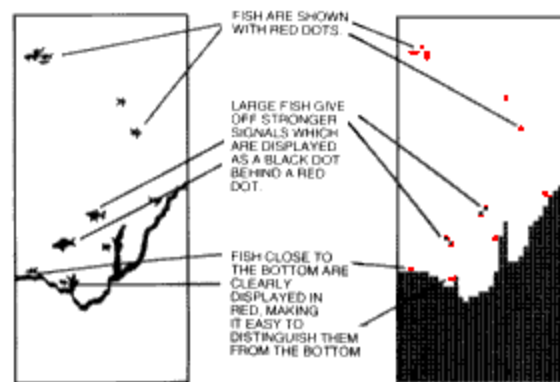

### Total Screen Update\*

Humminbird's exclusive Total Screen Update instantly updates the entire TCR screen to include new information each time a function is changed-no waiting for the changes to "march" onto the screen. This feature is valuable in 2 ways.

1. Changing depth ranges. When the depth range changes to a deeper or shallower scale, the entire screen changes to display the new depth scale. For example, if you're in the 0-

60' scale and it changes to the 0-30' scale, the entire screen will look as if you had been in the 0-30' range all along.

- Using zoom and bottom-lock. Through Pixel Memory Capacity, the memory in the TCR ID-10 stores readings in much finer detail than is displayed in the "regular mode. So when you activate the zoom or bottom-lock functions, the entire screen changes to display the up-close detail that is stored in memory. Then when you turn off the zoom or bottomlock, the whole screen will change back to the full depth scale.

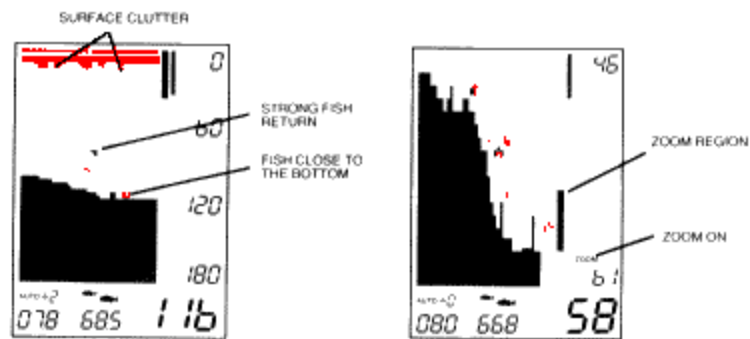
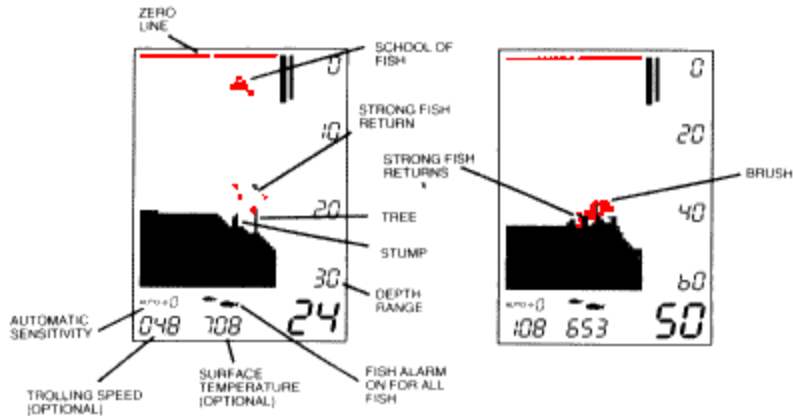

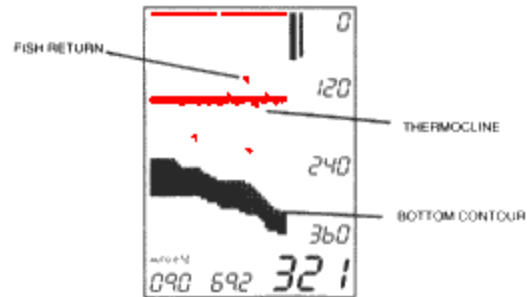
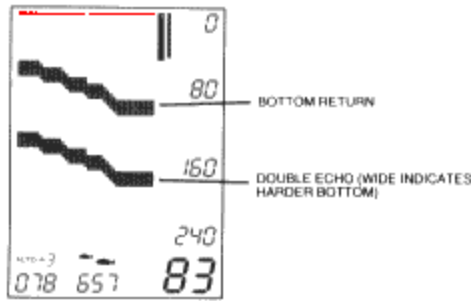
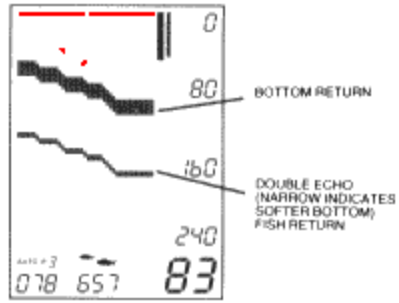

Of course, the best way to learn to read your TCR ID-10 is to use it, especially in familiar locations. If you know what's underwater and can see it displayed on the screen, then you're on your way to being an experienced TCR user.



## OPERATING THE TCR ID-10

Your new TCR ID-10 offers unique automatic features, as well as many adjustable ones. If you're learning to operate the TCR ID-10 with its simulator, follow the directions listed at "Built-In Simulator" on page 16, and then come back to this page. If you're learning to use your TCR ID10 using actual, on-the-water readings, proceed with the following instructions.

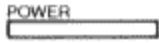

Power:

Pressing this button once turns the TCR ID-10 on. Pressing it once again turns it off. When the unit is turned off, holding this button down for about 2 seconds activates the built-in simulator.

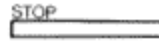

Stop:



By pressing this button once, you can stop or "freeze" the display. Pressing the button once again re-starts the display at its previous speed setting.

Light:

The TCR ID-10 features a 2-level backlight that evenly lights up the display from behind the screen. Pressing the "light" button once gives you a soft glow that's ideal for night fishing because it won't interfere with your night vision. Press the button again for a brighter light, making the display easy to read at dusk when it can be harder to see. Pressing the button a third time turns off the backlight.

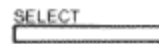

Select System:



The TCR ID-10 Select System commands an amazing number of functions with only four buttons: Select, Up and Down arrows, and On/Off.

When you press the Select button, each function appears in a block on the screen with easy-to-understand instructions for using the function. You use the Up and Down arrows and the On/Off button to adjust the functions. Then, the instructions disappear, returning the display to its full screen reading.

Select System functions are "active"; that is, the last function displayed on the screen can be adjusted without pressing the Select button again. This is valuable in 2 ways. Example 1: Re-adjusting a function. If bottom alarm was the last function used, you can adjust it again by pressing one of the arrow buttons or the On/Off button.

Example 2: Often-used function. If you think you'll be using zoom often, you can go to the zoom function, let the instructions disappear, and then activate the zoom when you need it simply by pressing On/ Off.

The following describes the functions and how to use them, in order of appearance after you turn the unit on.

1. Sensitivity

Automatic setting: on, "0" or normal

As conditions change, the computer will automatically increase or decrease the sensitivity setting. You can manually increase or decrease the automatic setting from a range of "+5" to "-5." This level will maintain itself as long as you have the unit on, automatically, as a result of the TCR's Sensitivity Bias feature. For example, if you set the sensitivity at "+2," the sensitivity will remain 2 settings higher than the normal automatic settings until you turn the TCR off.

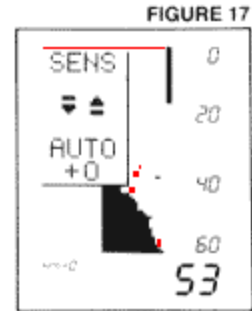

2. Bottom Alarm

Automatic setting: off

Use the On/Off button to activate the alarm, and the alarm cursor appears on the screen. Then use the arrow keys to adjust the depth at which the alarm will sound. You'll hear a continuous chirping sound when the bottom is within the area that you've defined with the alarm cursor. This is a great feature to use to alert you to shallow water, or to maintain your position over structure.

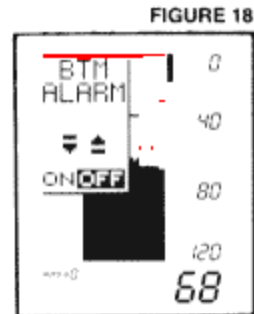

3. Fish Alarm

Automatic setting: off

The fish alarm is easily activated by pressing the On/Off button. This 2-level alarm can be set to sound for all fish, or to ignore weaker signals and alarm only for stronger signals, such as those from larger fish. You can also adjust the volume of the fish alarm.

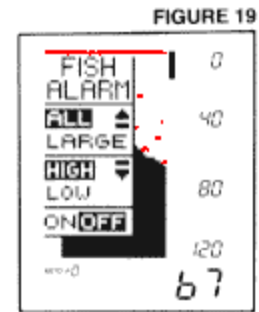

The controls for this function are a little different. Pressing the Up arrow lets you switch between alarms for all fish and large fish. The Down arrow controls volume of the alarm.

Once the instructions have disappeared from the screen, it's easy to tell which alarm you have activated-the alarm for all fish shows both small and large fish symbols at the bottom of the screen, while the "large only" alarm displays only a large fish symbol.

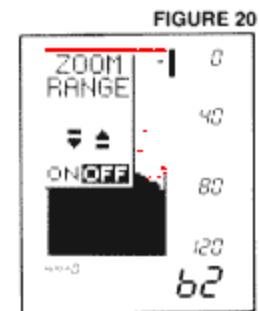

4. Zoom

Automatic setting: off

When zoom is activated by pressing On/Off, it creates a "window" of expanded, up-close information. This window is marked by a cursor at the right of the screen and can be moved up or down with the arrow buttons. The exact depths of the upper and lower limits of the window are displayed as depth scales while you are in zoom.

The size of the zoom window changes as the depth range changes. The window displays 71/2 feet of upclose readings in the 15' and 30' scales, and 15 feet in the 60' and 120' and 30 feet in the 180', 240', 360' and 480' scales. Keep in mind that, using your arrow

buttons, you can move the zoom window while the zoom is activated, without having to press Select again.

5. Bottom-Lock  
Automatic setting: off

You can easily turn on the bottom-lock with the On/Off button. When on, this function shows up-close zoom readings in reference to the bottom. The size of the zoom window depends on the depth range-71/2 feet in the 15' and 30' ranges, and 15 feet in the 60' and 120' ranges and 30 feet in the 180', 240' 360' and 480' ranges. The zoom window will automatically move up or down to stay on the bottom, with the cursor showing you the portion of the total depth range that is being displayed. This is an ideal feature for finding structure or locating fish near the bottom.

FIGURE 21

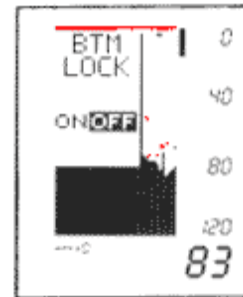

6. Display Speed  
Automatic setting: one setting less than highest speed

The speed at which the TCR display moves depends on the display speed setting, and it is easily changed by pressing the Up arrow for a faster setting and the Down arrow for a slower setting. Generally speaking, the higher speed settings allow faster updates, while slower display speeds provide more information.

FIGURE 22

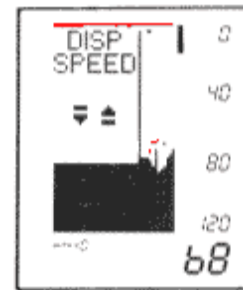

7. Depth Range  
Automatic setting: on

The TCR automatically finds the bottom, and then sets and displays the ideal depth range when you turn the unit on. If you choose to leave the auto range change on, the bottom will remain "blacked in" for easy-to-understand readings, and the depth ranges will change automatically.

Or, you can turn the auto-change off, allowing you to change the depth range manually. In this mode, the bottom is not blacked in. This lets you see a double bottom echo, which is preferred by some fishermen because the width of the second echo can indicate bottom texture.

FIGURE 23

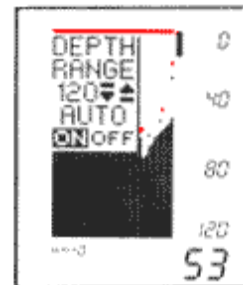

## Free Manuals Download Website

<http://myh66.com>

<http://usermanuals.us>

<http://www.somanuals.com>

<http://www.4manuals.cc>

<http://www.manual-lib.com>

<http://www.404manual.com>

<http://www.luxmanual.com>

<http://aubethermostatmanual.com>

Golf course search by state

<http://golfingnear.com>

Email search by domain

<http://emailbydomain.com>

Auto manuals search

<http://auto.somanuals.com>

TV manuals search

<http://tv.somanuals.com>