

# HUSKIE HYDRAULIC HAMMERS

## SERVICE MANUAL

**HH1500**

**HH2000**

**HH3600**

**HH4500**

**HH5800**

**HH8000**

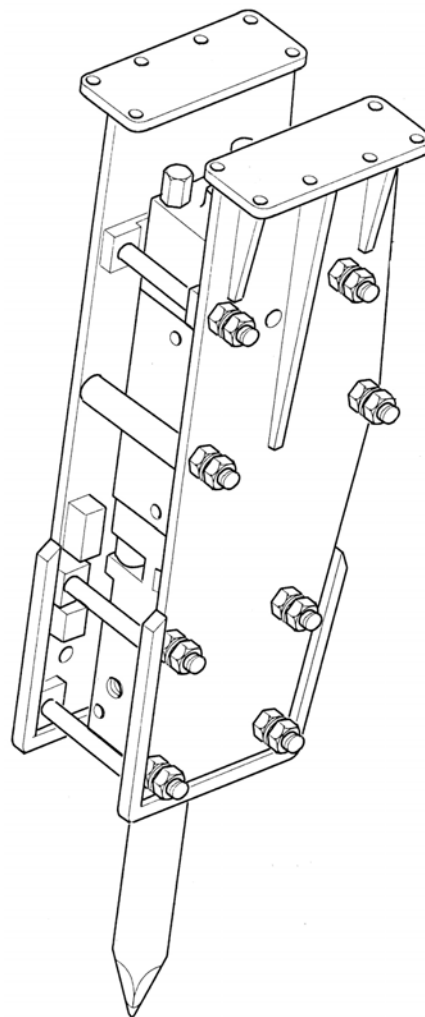
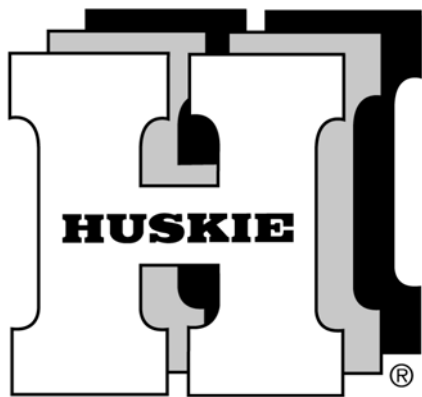

# CONTENTS

<b>1. Safety Information</b>	<b>Page 3</b>
Safety Decals Safety Symbols	
<b>2. Operating Instructions</b>	<b>Page 6</b>
How the Hammer Operates Mounting the Hammer to Carrier Connecting Hoses Daily Inspection before Operation Initial Startup, Hammer Break-in General Operation Instructions Cold Weather Startup and Operation Underwater Operation Storage Tool Replacement	
<b>3. Maintenance</b>	<b>Page 12</b>
Hydraulic Oil Checking Condition of Hydraulic Oil Fasteners Greasing Requirements Nitrogen (N <sub>2</sub> ) Gas Pressure Adjustment Oil Leakage Inspection Gas Leakage Inspection	
<b>4. Disassembly and Assembly</b>	<b>Page 18</b>
Disassembly Inspection of Parts Component Wear Limits Assembly	
<b>5. Specifications</b>	<b>Page 26</b>
<b>6. Refinishing of Pistons and Cylinders</b>	<b>Page 27</b>
<b>7. Troubleshooting Diagnosis</b>	<b>Page 28</b>
<b>8. Warranty Guide Lines</b>	<b>Page 29</b>
<b>9. Parts List and Illustrations</b>	<b>Page 33</b>

# 1. SAFETY INFORMATION

- Always read the information in this manual before operating the hammer. Failure to do so can result in personal injury or damage to the equipment.
- Check that all safety decals attached to the hammer and carrier are legible. Replace worn or illegible decals.
- Do not use drugs or alcoholic beverages that impair alertness or coordination while operating the carrier or hammer. An operator taking prescription drugs must obtain professional medical advice to determine if he/she can safely operate the carrier and hammer.
- Work at a slow pace when learning to operate the hammer.
- Operator training must consist of a demonstration and verbal instruction.
- New operators must start in an area free of bystanders. He/she must become familiar with all carrier controls before operating the hammer.
- Be aware of any prohibited uses in work areas. (Excessive slopes, poor or dangerous terrain conditions and utility hazards.)
- Operate the carrier or hammer from the operator's seat **ONLY**. Make sure the seat is fastened securely before activating controls.
- Keep hands and feet on the controls at all times while the hammer is operating.
- Always operate the carrier with the outriggers firmly positioned on the surface.
- Make sure all controls (levers and pedals) are in **NEUTRAL** before starting the carrier.
- **NEVER** leave the carrier with the engine running. **ALWAYS ENGAGE THE PARKING BRAKE.**
- Make certain there are no persons within the arc determined by the movement of stabilizers, front bucket or backhoe boom with the hammer at full extension.
- Never operate with any person near the hammer or between the hammer and the operator.
- Replace all faulty or leaking hydraulic hoses or fittings before operation.
- Travel with the hammer in the full tuck (transport) position only.
- Never operate the hammer with the tool retaining pin removed.
- Wear safety goggles, hearing protection and hardhat while operating the hammer.
- Before leaving the operator's seat, always lower the carrier boom or bucket arms.
- Stop the engine before attempting to make any repairs or adjustments to either the carrier or the hammer.
- **ALWAYS OBSERVE ALL SAFETY INSTRUCTIONS APPLICABLE TO YOUR CARRIER.**

## SAFETY DECALS

The decals shown below are attached to the hammer when shipped from the factory. Read and understand them before operating the hammer. Replace any decal that has become worn, damaged or illegible. Decals can be ordered through the parts department.

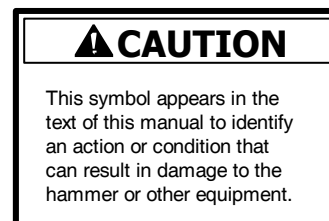
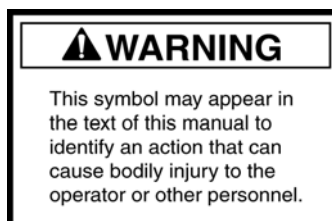
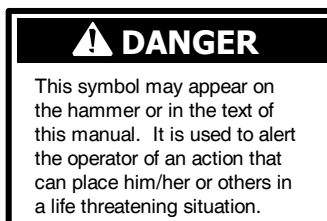
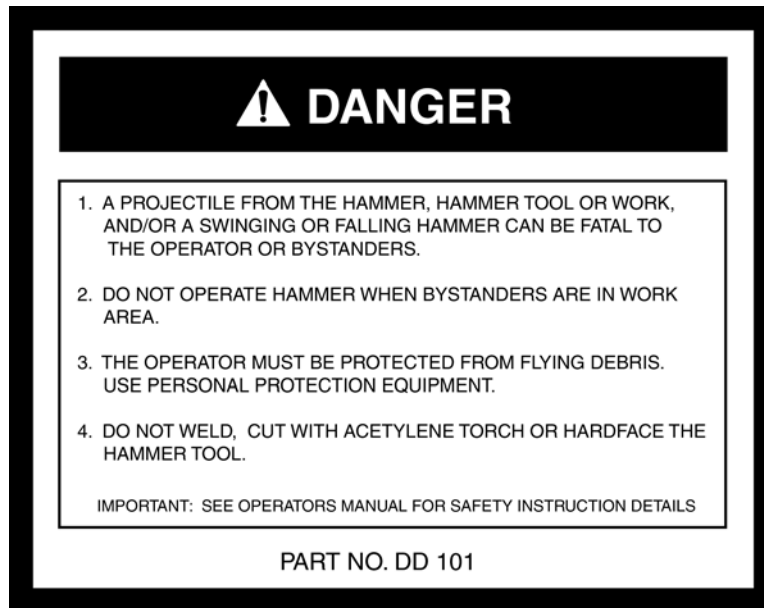

The notice below is included in the shipping carton. It contains information relating to operator safety. Read and understand this notice before unpacking or operating the hammer. We suggest you retain this notice and include it in your local safety program.

# CAUTION

**Never operate the hammer unless the following Safety Instructions have been read and understood.**

- Projectiles from the hammer, tool, rock or other broken material may enter the operator's area and cause serious or fatal injury. Use personal protection equipment.
- Projectiles from the hammer, tool, rock or other broken material may cause serious or fatal injury to bystanders. Do not operate the hammer when bystanders are in the area.
- In some cases, the hammer may enter the operator's area if a bracket or cylinder breaks. Make sure appropriate shields are used when operating the hammer with this type of equipment.

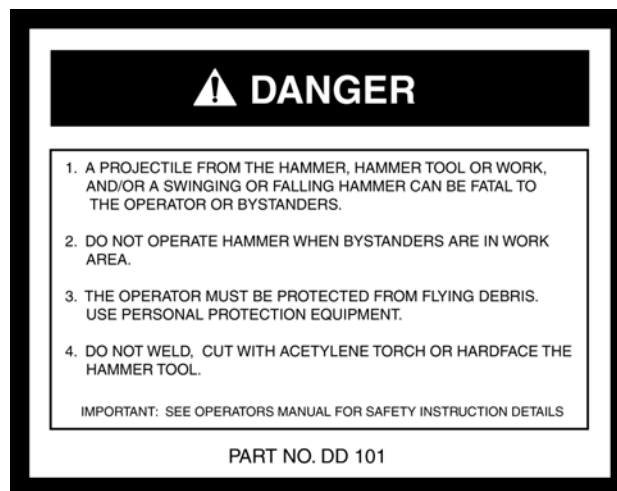

- Shown above is a copy of a decal that must be installed on a surface of the hammer that faces the operator and on the carrier operator's control area.
- Never operate the hammer if these decals are missing. Decals must be inspected periodically to ensure that all wording is legible. Decals should be replaced if illegible.
- Decals can be obtained at no charge from your IPC Distributor or by contacting IPC's Customer Service Department.

## 2. OPERATING INSTRUCTIONS

### HOW THE HAMMER OPERATES

On larger hammers the main valve is contained in the valve box, which is bolted to the cylinder (Figure 1). During the upward stroke, the pressure in the upper chamber is released via the main valve and through the outlet. High pressure in the lower chamber then forces the piston upward.

As soon as the piston reaches the upper end of the stroke, the main valve directs flow to the upper chamber causing it to become high pressure.

Since surface **A** is greater than surface **B**, the piston is driven downward with the help of the accumulated energy from the gas chamber, creating the impact stroke of the hammer.

At the point of impact, the main valve shifts, releasing the high pressure from the upper chamber, enabling the upward stroke to occur again.

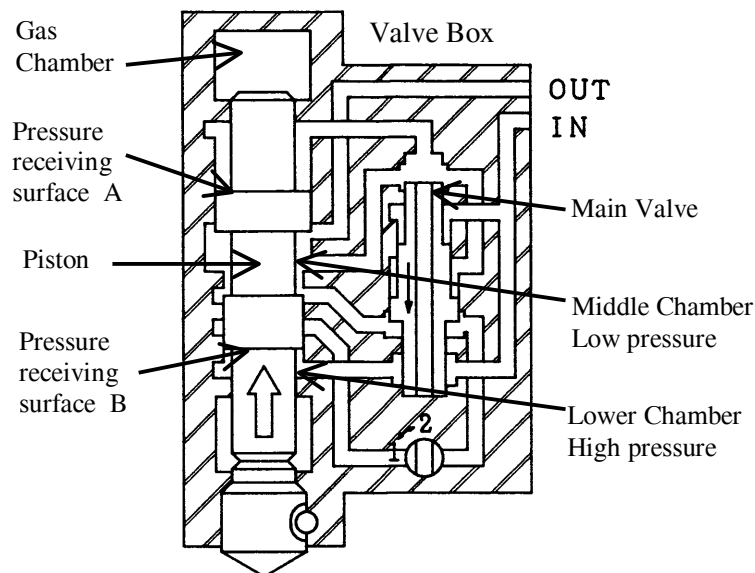

Figure 1. Principle of Operation



### CAUTION

**MATCH CARRIER HYDRAULIC FLOW TO CORRECT FLOW RANGE FOR HAMMER TO PREVENT INTERNAL DAMAGE TO HAMMER. CONTACT YOUR DEALER FOR CARRIER SPECIFICATIONS.**

(Refer to Table 10.)

## MOUNTING THE HAMMER TO THE CARRIER

### 1. Skid Steer Loader

All hammers are mounted to hammer brackets, which are then mounted to an adapter plate using two pins. The adapter plate is mounted to the quick mount of the carrier. To remove the hammer, first disconnect the hydraulic couplers from the inlet and outlet ports and detach the quick mount. Seal off all plugs and hoses to prevent dust, dirt and foreign particles from entering the system.

### 2. Rubber-Tired Backhoes and Excavators

All hammers are mounted to hammer brackets. The hammer brackets are mounted to the stick of the carrier using two pins and four bushings. To remove the hammer, first disconnect the hydraulic couplers from the inlet and outlet ports. Seal the couplers and hoses to prevent dust, dirt, and foreign particles from entering the system. Remove the “mounting pins” to detach hammer and bracket from the carrier stick.

## CONNECTING HOSES

Connect the two hydraulic hoses to the inlet and outlet ports of the carrier using shut off valves. When connecting, make sure that the ends are clean and engaged securely.

## DAILY INSPECTION BEFORE OPERATION

1. Check the carrier hydraulic oil level before operation. The hydraulic oil level must be correct for proper operation.
2. Check the hydraulic oil for any signs of contamination or discoloration. If any signs of contamination appear, change the oil. (Refer to Table 2.)

**NOTE:** Do not mix different types of hydraulic oil.

3. Inspect all hoses and fittings for leaks or damage. Check all fasteners and tighten as required. Replace any broken fasteners.
4. The hammer must be greased daily before use. Ten shots of grease with a grease gun is adequate. The hammer should be greased every 2-3 hours during operation. (See Figure 2)
5. Check the temperature of the hydraulic oil. Optimum operating temperature is 120°/ 200° F (49°/93°C). The unit may not function properly and seal damage may result if the hydraulic oil temperature goes beyond the recommended range.

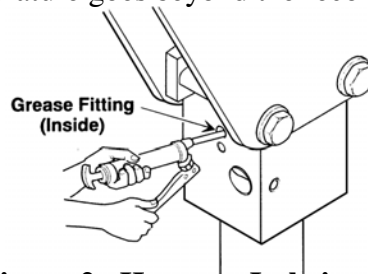

**Figure 2. Hammer Lubrication Point**

## **INITIAL STARTUP, HAMMER BREAK-IN**

New or rebuilt hammers require 20-40 minutes of operation at half the rated speed as a break-in period. This allows for proper lubrication of all moving parts and for all sliding surfaces to mate properly.

## **GENERAL OPERATING INSTRUCTIONS**

1. Never apply the tool with a side load. The tool must always be pressed firmly against, and be perpendicular to the material to be broken. Failure to do so can cause tool or seal failure.
2. Impact action must be stopped immediately when the object has been broken.
3. Do not pry with the tool. This may cause the tool to break or cause abnormal wear to the tool bushings.
4. Avoid continuous impact on the same area for more than one minute. Continuous impact may cause a rapid increase in oil temperature and improper hammer operation.
5. Break large objects from the outside edges and work inward.
6. Do not submerge the hammer in water. The hammer is not watertight, and damage can occur if used in this manner. Consult your dealer for underwater applications (Ref. Figure 3.)
7. Do not use the hammer to move very large or heavy broken objects. This can cause damage to the hammer and carrier.
8. Do not use the hammer as a lifting device.
9. Do not operate the hammer when boom cylinders are at their extreme ends. This may cause damage to the cylinders.
10. Stop operation immediately if hoses vibrate abnormally or impact energy is dramatically reduced. Consult Section 7. "Troubleshooting Diagnosis" for additional information.

## **COLD WEATHER STARTUP AND OPERATION**

**Note:** Internal parts of the hammer will be damaged if proper warm-up procedures are not applied in cold weather.

1. Warm the hydraulic system of the carrier before starting the hammer. Circulate the oil in carrier system until it is warm to the touch or approximately 60°F (15°C)
2. With engine at half throttle, activate the hammer for 5 seconds and stop for 15 seconds. Repeat cycle for 2 to 3 minutes.



## UNDERWATER OPERATION

Operation of hydraulic hammers under water requires proper preparation to prevent internal damage to hammer parts and carrier hydraulic system.

### CAUTION

DO NOT OPERATE MOUNTED HYDRAULIC HAMMER UNDERWATER WITHOUT AIR SUPPLY TO THE HAMMER. SERIOUS DAMAGE WILL RESULT TO THE PISTON, SEALS AND OTHER INTERNAL PARTS AS WATER AND ABRASIVE SOLIDS ARE DRAWN INTO THE FRONT CAP CAVITY AND FORCED INTO THE HYDRAULIC CIRCUIT DURING OPERATION.

### CAUTION

DO NOT SUBMERGE HOT HAMMER BODY IN WATER. HAMMER BODY WILL CONTRACT AND CAUSE PISTON SCORING AND SEIZURE.

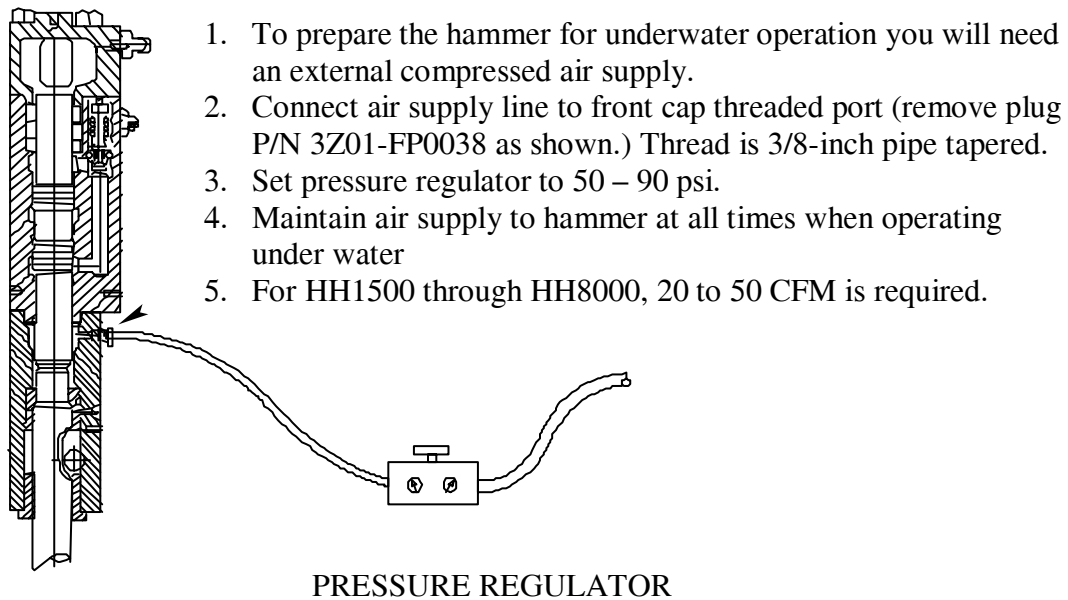

**Figure 3. Air Compressor Supply**

## STORAGE



### 1. Short Term

If the hammer will not be used for periods of one week or more, the tool should be removed from the hammer and grease must be applied to the piston bottom. The hammer should be stored indoors standing vertically in the working position.

### 2. Long Term

For storage of more than 2 - 3 weeks or where condensation or corrosion is prevalent (salt-water areas) note the following instructions. Remove and clean the tool. Flush the front cap with clean solvent or hydraulic oil. Coat the exposed portion of the piston with grease, apply grease to the tool and re-install. Store the hammer vertically and away from standing moisture. To start the hammer after long-term storage, remove the tool and inspect the exposed portion of the piston for corrosion. If corrosion is found do not use the hammer until the defective piston has been repaired or replaced.

## TOOL REPLACEMENT



**Table 1. Standard Tool Weights**

<b>TOOL WEIGHTS</b>	<b>Kg</b>	<b>lbs.</b>
HH1500	45	99
HH2000	74	162
HH3600	118	260
HH4500	152	334
HH5800	174	381
HH8000	214	470

- Carefully drive out the tool spring pin.
- Push the tool set pin up and out of the front cap using a screwdriver or round bar.

**Note:** Check Table 1, Page 10, before handling tools.

- For models HH100 through HH750-2, manual removal is possible.
- For hammer models HH1000-2 and larger use hoist and sling as shown. Check for sling load rating and compare to Table 1, Page 10.
- When installing the tool in the hammer, reverse steps 1 through 4 above. Note that tool spring pin must be inserted with the slot or open side away from the tool set pin.

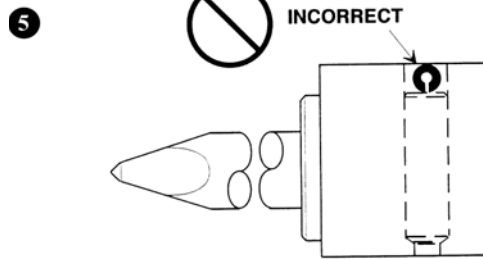
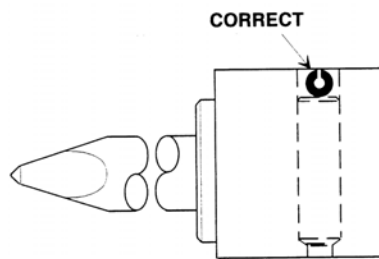
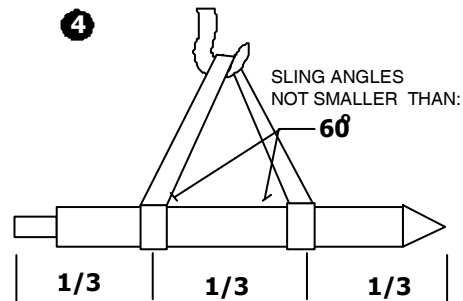
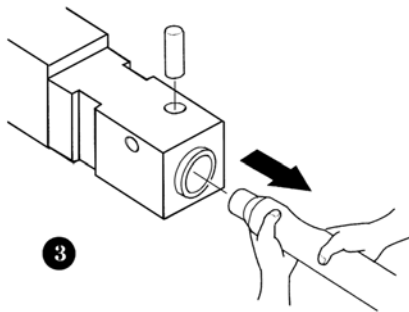
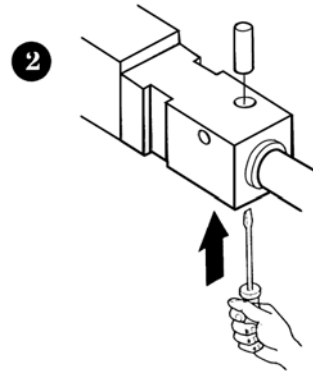
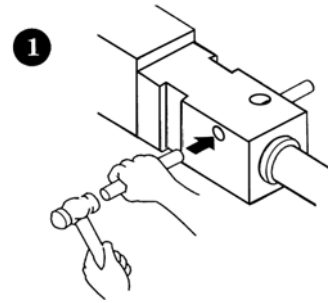

**Figure 4. Tool Replacement**

# 3. MAINTENANCE

## HYDRAULIC OIL

**Note:** It is not recommended to mix types of hydraulic oils. Check carriers hydraulic oil recommendations before adding hydraulic oil.

1. Check the oil level, oil filter condition and oil cooler in the carrier periodically.
2. Replace the hydraulic oil every 600 hours and the filter every 100 hours, or according to carrier recommendations.
3. Always be aware of any abnormalities in the operation of the hammer such as changes to hammer blow speed, impact force or oil temperature. The oil temperature should not exceed 180°F (80°C).
4. Check the condition of the hydraulic oil as specified in Table 2.

## CHECKING CONDITION OF HYDRAULIC OIL

**Note:** Refer to carrier service manual for proper class and type of hydraulic oil.

Hydraulic oil must be changed more frequently than the carrier instruction manual recommends. This is because hammer operation requires more oil circulation than normal operation. Oil condition can be visually checked as specified in Table 2.

**Table 2. Hydraulic Oil Conditions**

COLOR	CONDITION
Transparent and no color change	Good
Transparent but too bright	Oil Mixed
Milky white	Air and / or water mixed
Dark and dirty with odor	Deteriorated
Transparent but with black spots	Foreign particles mixed
Bubbly	Grease mixed

## FASTENERS

Inspect all bolts and nuts for tightness. Tighten as required. (Refer to Table 4.) Replace all missing or damaged fasteners before operating the hammer.



Fastener bolt and nut sizes are listed in Table 3. These are wrench sizes (distance across flats.)

**Table 3. Bolt Sizes**

HAMMER	NIPPLES (mm.)	BRACKET BOLTS (mm.)	SIDE RODS (mm.)	LIFTING EYES (inches)	VALVE BOX		GAS VALVE	
					*CAP BOLTS	SET BOLTS (mm.)	CAP (inches)	BODY (mm.)
1500	36	50	54	¾"-10pt	*14	30	1" Crow Foot	36
2000	36	50	54	7/8"- 9unc	*17	30	1" Crow Foot	36
3600	46	60	63	7/8"- 9unc	*17	32	1" Crow Foot	36
4500	46	75	71	1"-8unc	*17	32	1" Crow Foot	36
5800	46	75	85	1 ¼"- 8unc	*19	41	1" Crow Foot	36
8000	50	75	90	1 ½"- 6unc	*19	41	1" Crow Foot	36

\* Allen wrench size for the front and back cap bolts.

**Table 4. Tightening Torque Requirements (Ft. lbs.)**

	HH1500	HH2000	HH3600	HH4500	HH5800	HH8000
Side Rod	880 ±35	880 ±35	1100 ±35	1850 ±75	2560 ±75	3300 ±75
Valve Box Set Bolt	280 ±20	280 ±20	330 ±20	330 ±20	590 ±35	590 ±35
Valve Cap Bolt	175 ±20	280 ±20	330 ±20	330 ±20	480 ±35	480 ±35
Mode Valve Set Bolt	N/A	70 ±3	70 ±3	70 ±3	70 ±3	70 ±3
Bracket Bolt	400 ±35	840 ±35	1320 ±35	2600 ±35	2600 ±35	2600 ±35

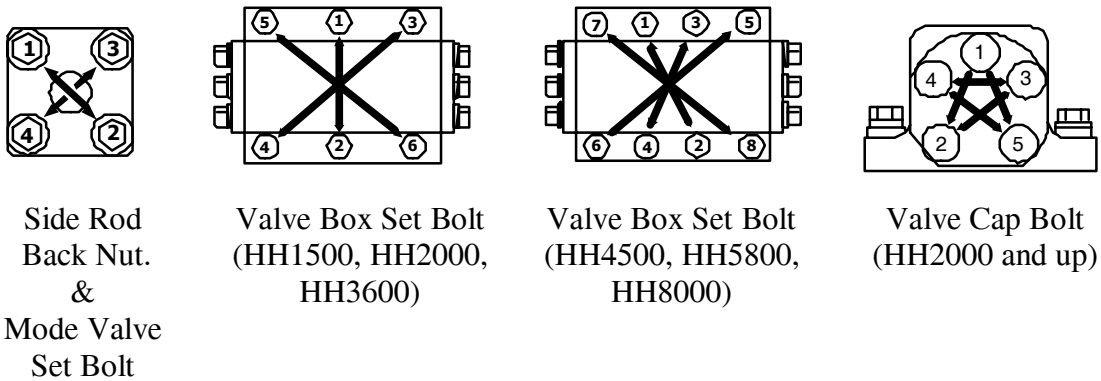

**Figure 5. Tightening Sequence**

## GREASING REQUIREMENTS

The hammer should be greased each startup and after every 2-3 hours of operation. The grease nipple is located at the front cap as shown in Figure 6. Approximately 10 shots in the front cap are recommended when the tool is at the upper limit of travel.

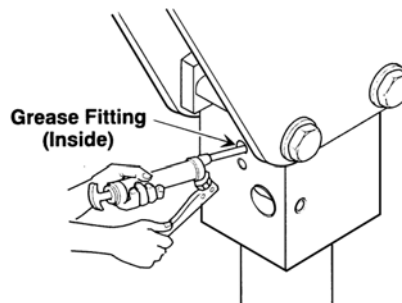

**Figure 6.**

## NITROGEN (N<sub>2</sub>) GAS PRESSURE ADJUSTMENT

The hammer will not operate properly and may not start due to an incorrect gas charge. Follow the procedure described below to adjust nitrogen (N<sub>2</sub>) gas pressure.

### WARNING!

**DO NOT STAND NEAR THE HAMMER WHEN ADDING NITRIGEN. THE TOOL MAY EJECT SUDDENLY AND CAUSE SEVERE INJURY.**

#### 1. Gas Pressure Testing.

- a. With the gas charger disconnected from the hammer, plug the inlet (the nitrogen hose connection port) of the gas charger with the cap provided, then turn the "T" handle fully to the left (counter clockwise.)
- b. Remove the gas valve cap located on the hammer back cap and attach gas charger, see Figure 7.

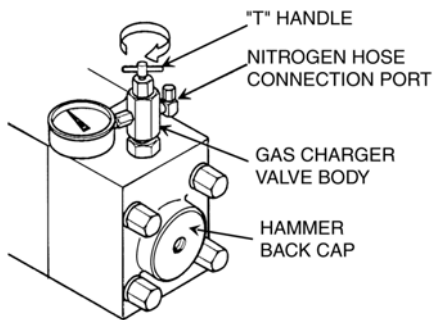

**Figure 7. Connecting Gas Charger to Hammer**

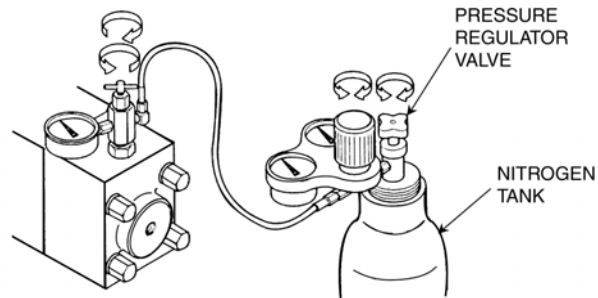

**Figure 8. Connecting Gas Charger to Nitrogen (N<sub>2</sub>) Supply**

- c. Turn the "T" handle on the gas charger valve clockwise, and then measure the N<sub>2</sub> gas pressure.

#### 2. Releasing Gas Pressure (if over charged or prior to disassembly)

- a. Test the gas pressure as described in paragraph 1.
- b. **For disassembly** loosen the bleeder screw on the gas charger very slowly and release the N<sub>2</sub> gas. Watch the pressure gauge until the nitrogen pressure is fully released. (see Figure 7 and 8.)
- c. **If overcharged** close the Bleeder Screw when the gas pressure reaches the correct gas pressure shown on Table 10, Page 26, then turn the "T" handle to the left (counter clockwise).
- d. Finally, remove the gas charger. Install and tighten the gas valve cap.

#### 3. Refilling Nitrogen (N<sub>2</sub>) Gas

- a. Perform paragraph 2 procedure.
- b. Remove the cap on the gas charger, nitrogen hose connection port. See Fig 9.
- c. Attach the N<sub>2</sub> gas pressure regulator to the gas container. Connect the nitrogen (N<sub>2</sub>) Supply tank to the gas charger with the charging kit hose.

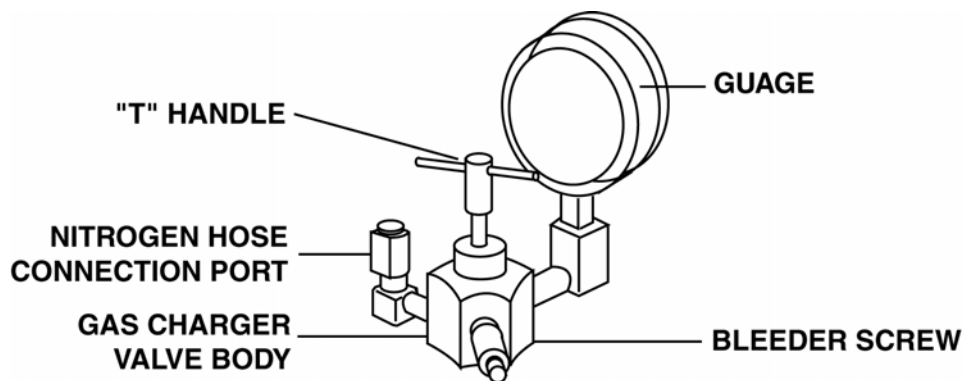

**Figure 9. Gas Charger Valve**

- d. Open the main gas valve on the N<sub>2</sub> gas container and regulate the N<sub>2</sub> gas pressure (see Figure 8.)
- e. Turn the gas charger "T" handle clockwise and adjust N<sub>2</sub> gas pressure in the gas chamber to the correct gas pressure shown on Table 10, Page 26.
- f. Turn the gas charger "T" handle fully counter clockwise and remove the hose. Attach the cap to the gas inlet of the charger.
- g. Remove the gas charger and attach the gas valve cap and O ring firmly to the gas valve nut on the hammer back cap.

## OIL LEAKAGE INSPECTION

Check for oil leakage at the points shown in Table 5. It is not unusual to have a small amount of oil leakage along the tool or cylinder, (refer to Figure 10.)

**Table 5. Diagnosis of Oil Leakage**

LEAK LOCATION	POSSIBLE CAUSE	REMEDY
Between front cap and tool (E)	Damaged or worn U-packing	Replace seal kit
Between cylinder and nipple (F)	Loose nipple or damaged O-ring or nipple	Tighten or replace nipple, and / or O-ring
Between cylinder and back cap (G)	Damaged U-packing or main Valve outer sleeve O-ring, or Back cap O-ring	Replace seal kit
Plug ports (H)	Plugs loosen	Remove plugs and reinstall with sealant



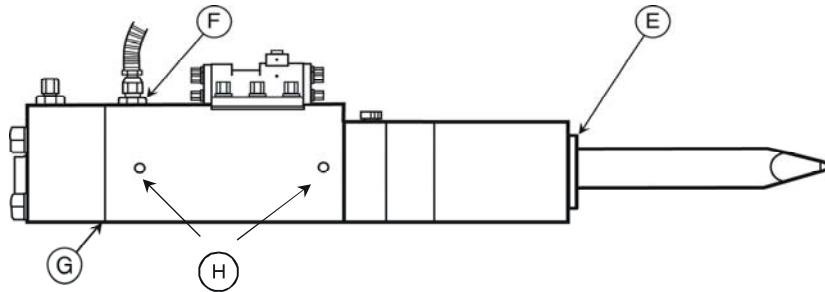

**Figure 10.**

## GAS LEAKAGE INSPECTION

Gas leakage can be easily detected using soapy water (refer to Table 6 and Figure 11.)



### CAUTION

ALWAYS MAINTAIN SPECIFIED NITROGEN GAS PRESSURE. IF GAS PRESSURE IS TOO LOW, HAMMER IMPACT FORCE MAY BE LOW. IF GAS PRESSURE IS TOO HIGH, AN INCREASE IN HYDRAULIC OIL TEMPERATURE MAY RESULT, CAUSING MALFUNCTION AND SHORT SEAL LIFE.

**Table 6. Diagnosis of Gas Leakage**

LEAK LOCATION	POSSIBLE CAUSE	REMEDY
Gas valve assembly (A) or Between gas valve assembly and back cap (B)	Defective O-ring, damaged Spring or gas valve	Replace gas valve assembly
Between back cap and cylinder (C)	Defective back cap O-ring	Replace back cap O-ring

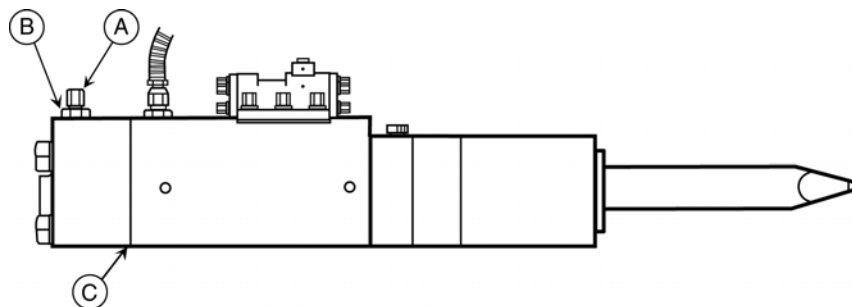

**Figure 11**

## 4. DISASSEMBLY AND ASSEMBLY

### **DANGER**

NITROGEN N<sub>2</sub> GAS MUST BE RELEASED BEFORE DISASSEMBLY OF HAMMER.

SEE "NITROGEN (N<sub>2</sub>) GAS PRESSURE ADJUSTMENT PROCEDURE".

### **CAUTION**

ASSEMBLY AND DISASSEMBLY MUST BE PERFORMED UNDER CLEAN CONDITIONS, FREE FROM DIRT AND FOREIGN PARTICLES.

### DISASSEMBLY

**1. Tool**

Refer to tool replacement procedures on Figure 4, page 11.

**2. Back cap**

Support the cylinder (Figure 12). Loosen and remove four side rods and washers, then remove the back cap.

**3. Front cap** (See Table 3 page 13 for eyebolt sizes)

Install an eyebolt and suspend the front cap as shown in Figure 12. Pull out the front cap, being careful not to damage the piston.

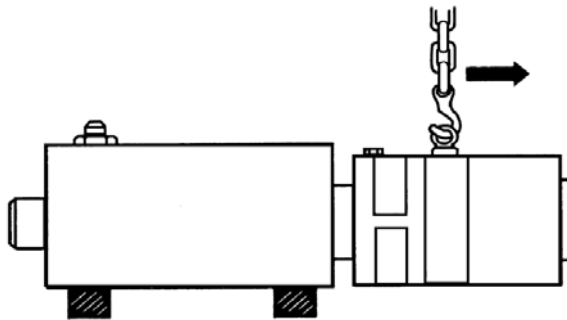

**Figure 12. Connecting Hoist to Front Cap.**

#### 4. Main Valve Box Assembly

Service of the Valve Box includes the Mode Valve Assembly and the Main Valve with Box Sleeve.

- a. Remove six or eight (depending on hammer model) Valve Box (4) Set Bolts and place Valve Box on a clean flat service.

**Note:** Inspect o-rings located at ports on cylinder and replace o-rings as necessary. When re-installing Valve Box check that all o-rings are in correct position.

- b. Remove four Mode Valve (1) Set Bolts and replace o-ring seals as necessary.

- c. Remove ten socket head cap screws and the Upper Valve Cap (3) and Lower Valve Cap (7).

- d. Remove the Box Sleeve (6) and the Main Valve (5) from the Lower Valve bore and inspect for scoring or wear.

**Note:** Minor scratches can be polished by hand using the same procedure as the piston and cylinders. Ref. Para. 6 page 27. Main Valve (5) and Box Sleeve (6) must be capable of free movement by hand without sticking or dragging. If not satisfactory replace with new parts.

- e. Reassemble by reversing above procedure.

**Note:** Keep work area clean and lubricate all parts with clean hydraulic oil during assembly.

- f. Torque bolts to proper specifications and sequence shown on Table 4 and figure 5 on page 14.

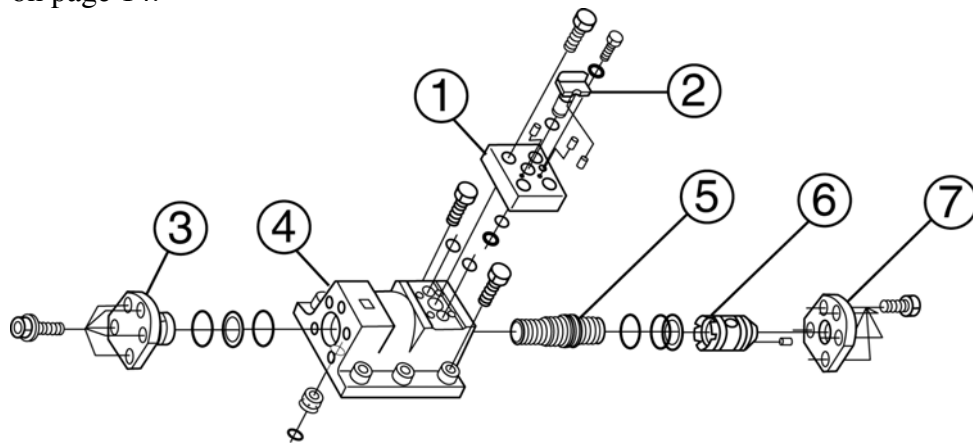
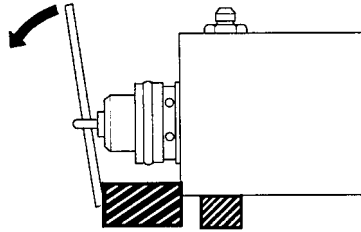

**Figure 13. Main Valve Box Assembly**

## 5. Piston (See Table 7 for Piston weights)

**Note:** For large hammers, you may wish to stand the hammer upright with proper support, and pull the piston upward using a lifting device.

- Attach an eye bolt to the top of the piston and pull out together with cylinder sleeve toward the top.
- It may be useful to use a pry bar as a lever as shown in Figure 14. Be careful to not damage the piston.

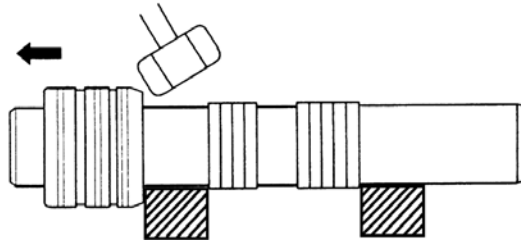

**Figure 14. Removing the piston.**

## 5. Cylinder sleeve

**Note:** Support piston on wood blocks.

Remove the cylinder sleeve from the piston. A plastic hammer or nylon bar can be used for removal as shown in Figure 15. Do not force the cylinder sleeve. Tap uniformly on all sides of the sleeve.



**Figure 15. Removing Cylinder Sleeve**

**Table. 7. Piston Weights**

HAMMER MODEL	WEIGHTS	
	kg	lbs.
HH1500	41	90
HH2000	64	142
HH3600	101	222
HH4500	122	270
HH5800	153	338
HH8000	198	436

## INSPECTION OF PARTS

### 1. Seals

Seals that are deformed, scratched, worn or aged should be replaced (see Figure 16). **It is recommended that all seals be replaced when disassembling the hammer.**

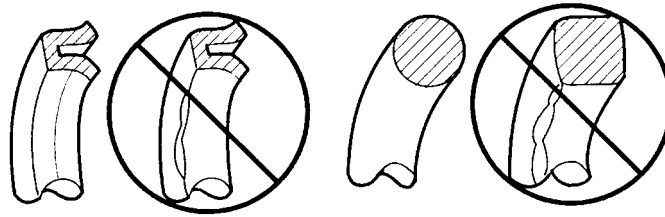

**Figure 16. Seal Conditions**

### 2. Moving parts

Check for any scratches or damage on the surface of the piston, cylinder sleeves, main valve and bottom part of the piston where it strikes the tool. Significantly damaged or scratched parts must be replaced.

### 3. Front cap

- a. Deformed or worn shank bushings or front cap bushings must be replaced, see Table 8 page 23.
- b. A severely worn or damaged tool set pin must be replaced.

### 4. Replacing the front cap bushing

- a. Measure shank and front cap bushings and refer to Table 8 page 23 and Table 9 page 24.
- b. Remove bushing set pin and bushing spring pin using a hammer and drive pin.
- c. The front cap bushing must be torch cut at three locations (at three 120° grooves) if it is the only bushing to be replaced. Avoid cutting into the front cap itself.
- d. Any scratches in the front cap must be smoothed after bushing removal.
- e. Install the new front cap bushing in the correct direction with part numbers on the bushing facing the installer (away from the hammer.) Because the bushings are a press, or interference fit, heating of the front cap and cooling of the bushing will help installation.
- f. Insert the bushing set pin and the bushing spring pin.

## **WARNING**

**BE CAREFUL OF HOT SURFACE. USE GLOVES TO PROTECT AGAINST BURNS AND POSSIBLE SHARP EDGES.**

## **5. Replacing the shank bushing**

**Note:** Replacement of the front cap bushing is required when replacing the shank bushing, as the front cap bushing must be removed to replace the shank bushing.

- a. Measure the shank and front cap bushing; refer to Table 8 page 23 and Table 9 page 24.
- b. Remove bushing spring pin and bushing set pin for shank bushing on the front cap using a punch and hammer.
- c. Press out shank bushing from the cylinder side together with front cap bushing using a round bar. If the shank bushing is too tight, cutting it with a torch may be required.
- d. Any scratches on the front cap during the cutting operation must be smoothed out using a hand grinder.
- e. Install a new shank bushing after greasing. As bushings are a press, or interference fit, heating of the front cap or cooling of the bushing will ease installation of the bushing.
- f. Install the bushing set pin and the bushing spring pin.

## **6. Refinishing surface scratches (see Section 6. Page 27)**

### **a. Cylinder and Cylinder Sleeve**

Scratches on the inside surface of the cylinder should be smoothed using a flap wheel with 240 grit and finish with 360 grit.

### **b. Piston**

Grind off any scratches on the outside surface using a flap wheel with 240 grit and finish with 360 grit. When polishing the piston or the cylinder bore, it is not necessary to completely remove scratches (only the sharp edges) as this may remove excess material. (See Figures 19, 20 and 21 on page 27.)

### **c. Main Valve and Sleeves**

Main valve and sleeves cannot be polished. Replace if these parts do not slide freely by finger pressure.

## COMPONENT WEAR LIMITS

Parts are to be replaced if not within the wear parameters. See Table 8 and Figure 17 below, for new dimensions see Table 9 page 24.

**Table 8. Component Wear Limits**

COMPONENT	WEAR LIMITS
Front cap bushing	When the clearance between the tool and the front cap bushing exceeds .300 in. (8mm), a new front cap bushing is required. (Approximately 500 hours of use).
Shank bushing	When the clearance between the tool and the shank bushing exceeds .160 in. (4mm), a new shank bushing is required. (Approximately 700 hours of use).
Tool	If .120 in. (3mm) of wear in the diameter is observed, a new tool is required. (Approximately 500 hours of use). Keep tool sharp.
Tool set pin	If .080 in. (2mm) of wear in the diameter is observed, a new tool set pin is required.
Front cap	If the corner of the front cap is worn to the edge of the front cap bushing, a new front cap is required.
Piston	When indentation or serious damage on the piston surface is observed, a new piston is required. (Approximately 2,000 hours of use).

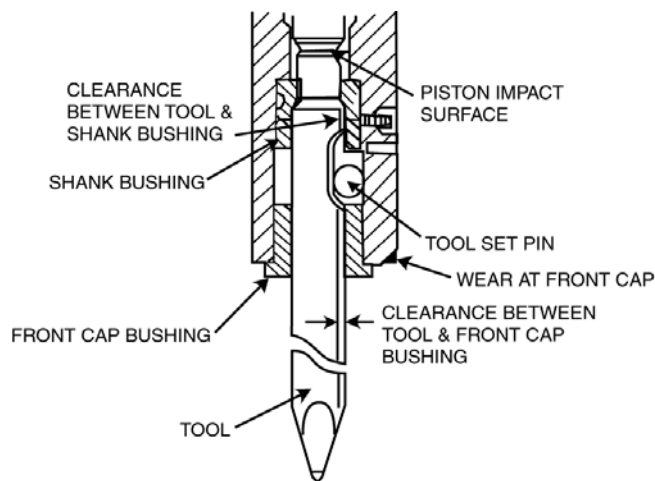

**Figure 17. Wear Limit Points**

**Table 9. New Component Dimensions**

<b>PART</b>	<b>HH1500</b>	<b>HH2000</b>	<b>HH3600</b>	<b>HH4500</b>	<b>HH5800</b>	<b>HH8000</b>
Front Cap Bushing I.D.	101. mm. 3.967 in.	116. mm. 4.567 in.	136. mm. 5.354 in.	146. mm. 5.748 in.	156. mm. 6.142 in.	166. mm. 6.535 in.
Shank Bushing I.D.	101. mm. 3.967 in.	116. mm. 4.567 in.	136. mm. 5.354 in.	146. mm. 5.748 in.	156. mm. 6.142 in.	166. mm. 6.535 in.
Tool O.D.	100. mm. 3.937 in.	115. mm. 4.528 in.	135. mm. 5.315 in.	145. mm. 5.709 in.	155. mm. 6.102 in.	165. mm. 6.496 in.

## ASSEMBLY

**Note:** Clean every part before assembly. Keep parts clean and do not scratch during assembly. Assembly can basically be done in the reverse order of disassembly. Make sure parts are installed in the correct direction.

1. Lubricate the U-packing, O-ring, piston, cylinder and main valve with hydraulic oil before assembly.
2. Place cylinder sleeve on the piston.
3. Insert the piston fully into the cylinder to its bottom position.
  - a. Make sure that all seals are positioned correctly and facing the right direction.
  - b. Handle seals very carefully in order not to cause scratches.
  - c. To avoid scratching the piston, the cylinder sleeve can be installed with a plastic hammer or nylon bar.
4. Install the front cap on the cylinder.
5. Insert the main valve and the outer sleeve.
6. Apply hydraulic oil into the back cap for gas seal lubrication. See Figure 18.
7. Attach the back cap to the cylinder.

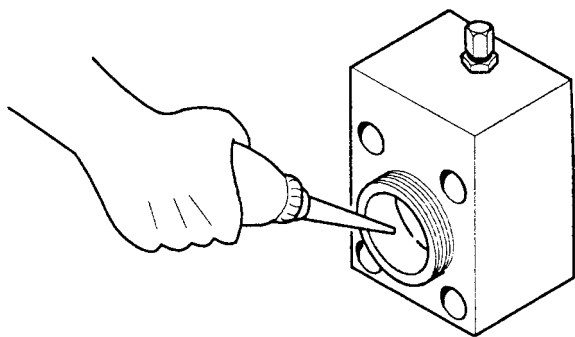

HH1500	1.0 oz. or 30 cc.
HH2000	3.5 oz. or 100 cc.
HH3600	5.0 oz. or 150. cc.
HH4500	5.0 oz. or 150. cc.
HH5800	5.0 oz. or 150. cc.
HH8000	6.0 oz. or 180. cc.

**Figure 18. Adding oil to the Back Cap.**



8. Insert and tighten the four side rods together with the washer to the specified torque (see Table 4 and Figure 5 on page 14.)
9. Refill the hammer with Nitrogen (N<sub>2</sub>) gas. Refer to pages 15 and 16.



Make sure that the piston is positioned at the lower end of its stroke before charging. The piston and the cylinder may be damaged during gas charging by sudden movement (due to a pressure increase) if the piston is not at the bottom of its stroke in the cylinder.

## 5. SPECIFICATIONS

Table 10. Specifications

ITEM	UNIT	HH1500	HH2000	HH3600	HH4500	HH5800	HH8000
Impact energy	ft-lbs. kg-m	1500	2000	3600	4500	5800	8000
Blows per minute	bpm	480-550	400-650 300-500	480-630 380-500	480-625 350-450	450-560 345-430	340-450 280-370
Required oil flow	gpm l/min	21.3-28.7 80-108	21.3-36.7 80-138	36-55 136-207	40-56 151-211	50-63 189-238	62-73 234-276
Operating pressure	psi bar	2000-2290 140-160	2000-2290 140-160	2290-2570 160-180	2430-2710 170-190	2430-2710 170-190	2430-2710 170-190
Nitrogen gas pressure	psi bar	140-160 10-11	140-175 10-12	160-185 11-13	160-185 11-13	160-185 11-13	160-185 11-13
Total weight with tool	lbs. kg	1400 636	2100 955	3200 1455	4200 1909	5400 2455	6800 3091
Total length	inch mm	70 176	78 199	90 228	98 250	105 266	116 294
Tool diameter	inch mm	4.0 100	4.5 115	5.3 135	5.7 140	6.1 155	6.5 165
Applicable carrier	lbs. kg	18000-30000 8200-13700	20000-40000 9070-18140	36000-58000 16330-26310	41000-70000 18600-31750	55000-90000 24950-40820	70000-130000 31750-58970
Carrier Relief Valve Setting	Psi Bar	2600-2900 180-200	2600-2900 180-200	2900-3300 200-230	2980-3550 210-250	2980-3550 210-250	2980-3550 210-250

### Remarks:

- The hammer is to be used within the specified oil pressure, oil flow and gas pressure parameters.
- The carrier hydraulic system relief pressure is to be set at 600 to 800 psi above the hammer "Operating Pressure."
- Hydraulic pressure is to be measured at the hose end of the carrier (output or pressure hose) when disconnected from the hammer.

## 6. REFINISHING OF PISTONS & CYLINDERS

If the pistons and cylinders should be scored or scratched due to dirty oil, or improper hydraulic oil specifications, the piston and cylinder can in many cases be polished and salvaged, instead of being replaced.

This is possible because the components in this hammer are made of high quality alloy steel and do not use chromium surface finishes which cannot be polished.

Follow the procedures in Figures 19, 20 & 21 and finish by thorough flushing and cleaning. These parts can usually be salvaged.

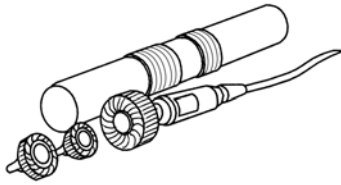

**Figure 19.**

**Caution:** Wear safety glasses for eye protection

Use hand held air grinder with flap type wheels.  
Two grit wheels were used:  
#240 for Heavy Polish.  
#360 for Finishing.

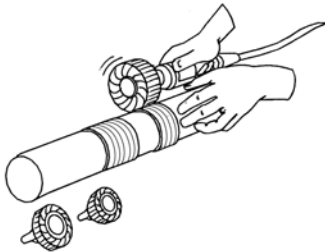

**Figure 20.**

Rotate piston and polish with brushing motion of grinder.

Polish total area before changing to fine grit for finishing.



**Figure 21.**

After completion of fine polishing, clean labyrinth grooves carefully with fine needle file to remove all burrs and rough edges.

After polishing all rough surfaces and edges, clean all parts by flushing thoroughly. Lubricate with hydraulic oil before reassembling.

**Note:** It is not necessary to completely remove all scoring or scratching to full depth of the scratches. Instead polish the surfaces until any raised edges are flush and smooth with the original surface. If this procedure is followed excess material will not be removed and normal tolerances can be maintained inside the hammer.

# 7. TROUBLESHOOTING DIAGNOSIS

Table 11. Troubleshooting

<b>SYMPTOM</b>	<b>POSSIBLE CAUSE</b>	<b>REMEDY</b>
Hammer does not run	Couplers are not engaged	Connect couplers securely
	Relief valve set incorrectly	Adjust main and secondary relief valve
	Malfunction of the hydraulic pump	Repair pump
	Nitrogen gas pressure is too high	Adjust gas pressure
	Main valve is damaged	Replace main valve
	Piston is damaged	Repair or replace piston
Hesitation or erratic operation	Couplers are not fully engaged	Connect couplers securely
	Relief valve set incorrectly	Adjust main and secondary relief valve
	Malfunction of the hydraulic pump	Repair pump
	Oil temperature is too high (exceeds 180°F or 80°C)	Check oil cooler
	Main valve is damaged	Replace damaged main valve
	Decreased oil flow	Avoid simultaneous axis movement
	Auto shut-off in operation, tool is suspended	Apply proper down force
	Excessive bushing wear	Replace worn bushings
	Piston is damaged	Repair or replace piston
Slow impact speed	Nitrogen pressure is too high	Adjust gas pressure
	Hydraulic oil leakage into the gas chamber	Replace seal kit
	Malfunction of the hydraulic pump	Repair pump
	Deteriorated or contaminated oil	Change oil
Low impact power	Nitrogen gas pressure is low	Adjust gas pressure
	Relief valve set incorrectly	Adjust main and secondary relief valve
	Malfunction of the hydraulic pump	Repair pump

## 8. WARRANTY GUIDE LINES

### **Time based on total man-hours.**

**Seal kit installation** (Includes testing, complete disassembly, cleaning and re-assembly)

HH100 - HH1000 = 4 hours

HH1500 - HH2000 = 6hours

HH3600 - HH4500 = 7hours

HH5800 – HH8000 = 8hours

**Front cap bushing** (Includes removal and re-installation, hammer disassembly not required)

HH150 - HH1000 ½ hour

HH1500 - HH8000 1 hour

**Shank bushing** (Includes complete disassembly, removal of both bushing and re-assembly)

HH150 - HH1000 = 3 hours

HH1500 - HH2000 = 4 hours

HH3600 – HH8000 = 5 hours

**Side rod replacement only** (Includes complete disassembly, removal of broken side rod and re-assembly)

HH150 - HH1000 = 2 hours

HH1500 - HH2000 = 3 hours

HH3600 - HH8000 = 4 hours

**Bracket bolt replacement**

HH100 - HH1000 = ¼ hour

HH1500 - HH8000 = ½ hour

IPC Industries, Inc.  
194 N. Brandon Dr.  
Glendale Heights, IL 60139

## LIMITED WARRANTY FOR HYDRAULIC HAMMERS

### LIMITED WARRANTY

The manufacturer warrants its Products against defects in material and workmanship. Such **LIMITED** warranty shall apply to the initial Purchaser only. The **BACK-CAP, MAIN BODY and FRONT CAP** carry a **LIFETIME, UNLIMITED HOURS** warranty. All other components (except seals and exclusions listed below) are warranted as follows: **THREE (3) YEARS, UNLIMITED HOURS**. Seals are warranted for a period of **TWO (2) YEARS, UNLIMITED HOURS**. All Warrantees begin from the date of sale to the original retail end-user or the initial rental service of the hammer.

### ITEMS EXCLUDED FROM THIS WARRANTY

Normal wear items such as tools (moil, chisel, blunt, tamper, frost wedge and asphalt cutter), shank bushings, tool bushings, set pins, hoses, hose adapters and accessories are specifically excluded from any and all warrantees.

### WARRANTY LIMITATIONS

This warranty will be in effect only if:

1. The Purchaser or his agent has the Product installed and operating in accordance with the published Manufacturers specifications and guidelines.
2. The Purchaser or his agent does not exceed the Products published design operating range for hydraulic flow, pressure or recommended carrier size.
3. The Purchaser or his agent complies with the maintenance schedule in the Operating and Service Manual supplied with each Product.
4. The Purchaser or his agent uses replacement parts/products received from or approved by IPC Industries, Inc.

This Warranty **will not** cover defects/failures caused by abuse, neglect, misuse, lack of maintenance, accident or use of the Product beyond its published design capacity, specifications or recommended applications.

The Manufacturer will authorize the return of defective components to the Manufacturers warehouse or location specified by the Manufacturer. The Manufacturer will determine if said components show clear and evident proof of defective material and/or workmanship. **A warranty claim will only be accepted if accompanied by proof of purchase and received within thirty-(30)-days of the warranted defect or failure.**

The Manufacturer will, at its option, determine what, if any, defective/faulty components will be accepted for warranty coverage. The Manufacturer will, at its option, determine whether to repair or replace components deemed faulty because of defective materials or workmanship. The manufacturer will not be accountable for mileage, travel time, travel costs, and/or any freight costs incurred to facilitate the needed replacement or repairs beyond those stated within the document (attached) titled "Warranty Policy Statement". The Manufacturer shall not be liable for lost rental income, machine availability or failure of components not supplied or installed by Manufacturer.

### WARRANTY DISCLAIMER

This Warranty is exclusive and in lieu of all other representations and warranties, expressed or implied. The Manufacturer expressly disclaims and excludes any implied warranty of merchantability or fitness for a particular purpose. In no event shall the Purchaser or his agent be entitled to any consequential damages of any kind, whether arising out of breach of contract, warranty (including negligence and strict liability) or other theories of law, with respect to products sold or services rendered by the Manufacturer, or any undertakings, acts or omissions relating thereto. The Manufacturer reserves the right to change these policies as conditions dictate.

July 1, 2005

# Warranty Policy Statement

This document explains IPC Industries, Inc. specific policies concerning submission and reconciliation of warranty claims. This document is in addition to and a part of the IPC Industries, Inc. *Limited Lifetime Warranty For Hydraulic Hammers* that accompanies all new hydraulic hammer products.

## 1. Warranty Registration Card

Each hydraulic hammer is shipped with a *Warranty Registration Card*. In order to properly process your claim this card **must** be on file at IPC. This card not only registers the product for warranty purposes it keeps IPC informed so we can contact you concerning product updates, parts specials and service bulletins.

## 2. Ordering Warranty Replacement Parts

All parts ordered from IPC will, **without exception**, be invoiced and shipped freight collect or prepaid with freight on the invoice. Warranted costs for freight will be resolved on the *Warranty Claim* form you will be returning with the defective part.

## 3. Filing a Claim

Every IPC product shipped includes two service manuals and a package containing a *Warranty Claim* form and a Delivery Report form for pre-delivery. The *Warranty Claim* form is located in the envelope labeled "Distributor Information".

## 4. Labor Reimbursement and Using the Warranty Claim Form

Fill out all items as completely as possible. Take note of (5.) below. In the section titled "DESCRIPTION OF FAILURE" describe the failure as clearly as possible along with operating conditions of the hammer **and** carrier as best you can.

In order for IPC to consider "DEALER LABOR" and "DEALER MILEAGE" in your claim, your **published** labor and mileage rates must be on file with IPC or must accompany the claim form. Please see (8.) below for an explanation of "FREIGHT (PAID)".

*In no event shall IPC Industries, Inc. warrant more than one (1) hour travel time (each way) or eight (8) hours of labor for a hammer repair.*

*Please refer to the service manual for easy to follow disassembly and assembly procedures. IPC Industries, Inc. would be pleased to provide you with no-charge "on-site" service training covering all aspects of hammer service.*

## 5. Warranty Submission Time Limit

No more than **thirty- (30)-days** can elapse between the "DATE OF FAILURE" and "DATE OF CLAIM". **Claims submitted beyond thirty- (30)-days from the "DATE OF FAILURE" will be denied.**

IPC's purpose is to provide the best possible product reliability and customer service. Our best sources for product reliability information and failure analysis are used/failed parts from the field. A part that has been exposed to weeks of weather tells us little or nothing. If we can't tell why or where a part failed because of rust or damage we can't warranty the part.

## **6. Requesting a Returned Goods Authorization (RGA)**

Before returning a suspected warranty part, call IPC at (800) 487-5431 and our customer service representatives will provide you with a RGA number. Please have the description of the part(s) at hand and the method by which you will be returning the part prepaid to IPC. At that time it may be determined that you need not return the part and IPC may, at its sole discretion, warrant the part without examination. Do not scrap any parts under warranty consideration unless authorized by IPC or credit is received.

## **7. Returning a Warranted Part**

All returned parts must be shipped prepaid (not collect) and include the RGA number prominently displayed on the shipping label. If a part is particularly heavy, please contact us for further information.

## **8. Warranty Part Freight Costs**

IPC Industries, Inc. will cover inbound (when requested by IPC) and outbound freight for warranted parts under the following circumstances *only*:

- IPC will cover *surface freight* costs for parts judged to be defective in materials or workmanship.
- The cost of shipping warranted parts via an expedited surface or air shipment will be paid as follows: IPC will pay the difference between standard surface freight and air or expedited surface freight, whichever is less.

## **9. IPC Claims Processing**

IPC will respond to the dealer submitting the claim within 30 days as follows:

- A credit for an approved claim which contains the required information or,
  - A request for further information, for return of the parts for analysis (refer to 6. and 7. above)
- or,
- Notification of a denied claim with an explanation of why the claim was denied.



## 9. PARTS LIST AND ILLUSTRATIONS

**HH1500**

**HH2000**

**HH3600**

**HH4500**

**HH5800**

**HH8000**

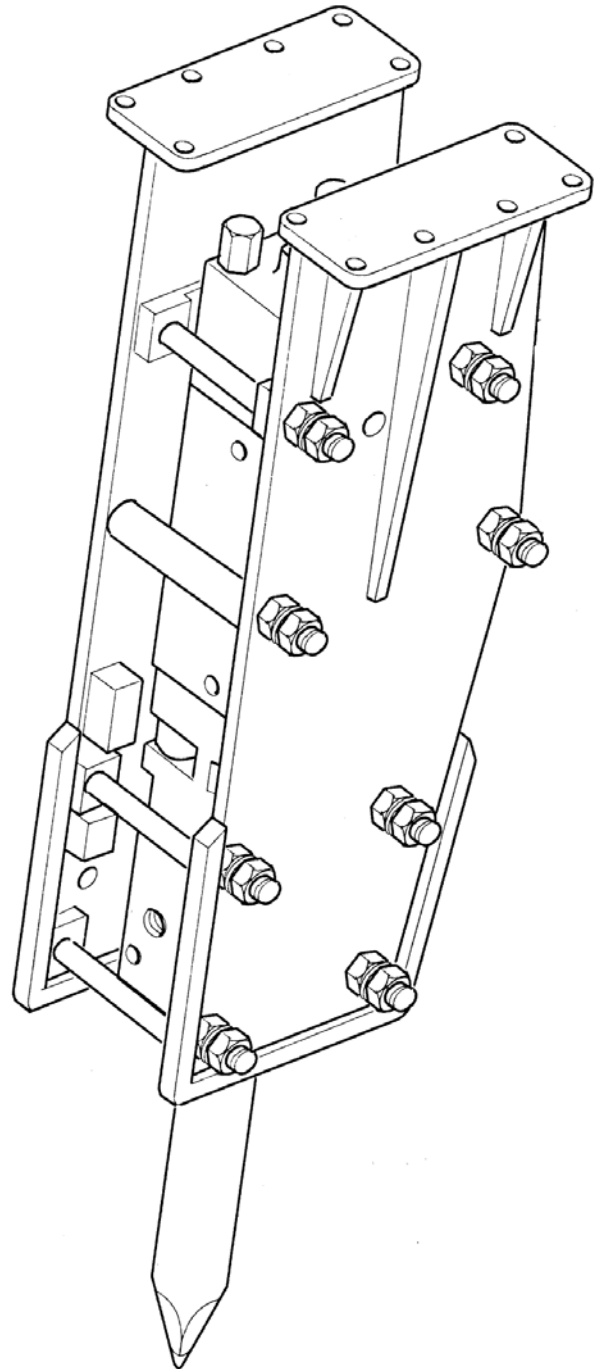

# HH1500 HAMMER

ITEM	NAME	NUMBER	QTY.
1	Cylinder	3J01-212001	1
2	Cylinder O-Ring*	Seal Kit	2
3	Cylinder O-Ring*	Seal Kit	2
4	Cylinder O-Ring*	Seal Kit	1
5	Cylinder Sleeve	3J01-212002	1
6	Cylinder Sleeve O-Ring*	Seal Kit	2
7	Quad Ring*	Seal Kit	1
8	Back Up Ring*	Seal Kit	1
9	Step Seal*	Seal Kit	1
10	Step Seal O-Ring*	Seal Kit	1
11	U-Packing*	Seal Kit	2
12	Dust Seal*	Seal Kit	1
13	Drain Plug	3Z01-DP0014	1
14	Choke Plug #1	3J01-2120095	1
15	Choke O-Ring*	3Z01-21209040B	1
16	Plug	3J01-2120081	1
17	Plug O-Ring*	3Z01-21209056W	1
18	Choke Plug #2	3J01-2120082	1
19	Plug O-Ring*	3Z01-21209040B	1
20	Piston	3J01-2120011	1
21	Valve Box	3J01-2120021	1
22	Main Valve	3F01-2100622	1
23	Main Valve Inner Sleeve	3E01-2060623	1
24	Main Valve Outer Sleeve	3E01-2060624	1
25	Main Valve O-Ring*	3E01-09092B	1
26	Valve Cap	3J01-2120023	1
27	Valve Cap Bolt	3J01-C4009B	4
28	Valve Box Set Bolt	3H01-B48138	6
29	Back Cap	3J01-2120031	1
30	Back Cap O-Ring*	Seal Kit	1
31	Front Cap	3J01-2120041	1
32	Front Cap Plug	3Z01-FP0038	1
33	Shank Bushing	3J01-2120042	1
34	Front Cap Bushing	3J01-2120043	1
35	Bushing Set Pin	3J01-2120044	3
36	Bushing Spring Pin	3H01-S40108	6
37	Nipple PF—3/4in.—1.1/16in. UN	3F03-N00002	2
38	O-Ring 1BG-30	Ass'y of item 37	2
39	Side Rod Assembly	3J01-2120051	4
40	Side Rod Front Nut	Ass'y of item 39	4
41	Side Rod Back Nut	Ass'y of item 39	4
42	Side Rod Washer	Ass'y of item 39	4
43	Grease Nipple	3Z01-GN0018	1
44	Tool Set Pin	3J01-2120061	1
45	Tool Spring Pin	3H01-S40248	2
46	Tool Moil (Chisel, Blunt)	3J01-212P(Fx, E)	1
NI	Seal Kit	3J01-212SK	1
NI	Gas Charger	3Z01-202GC	1
47	Gas Valve Assembly (Includes item # 48)	3Z01-G00001	1
48	Gas Valve Cap with O-Ring	3Z01-G00004	1

\*Included in seal kit. NI denotes not illustrated.

Effective 07/05

# HH1500 HAMMER

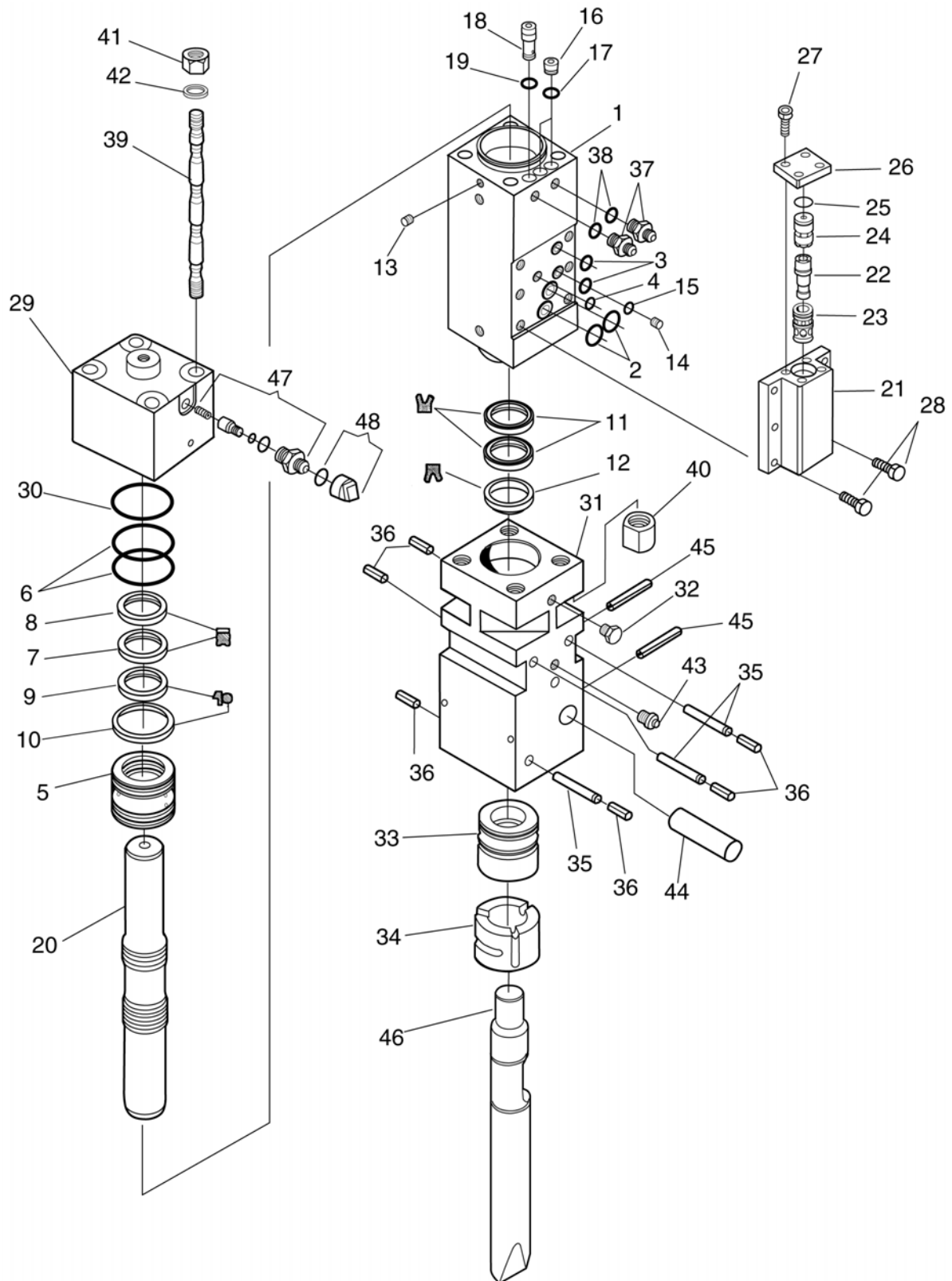

Effective 07/05

# HH1500 HAMMER

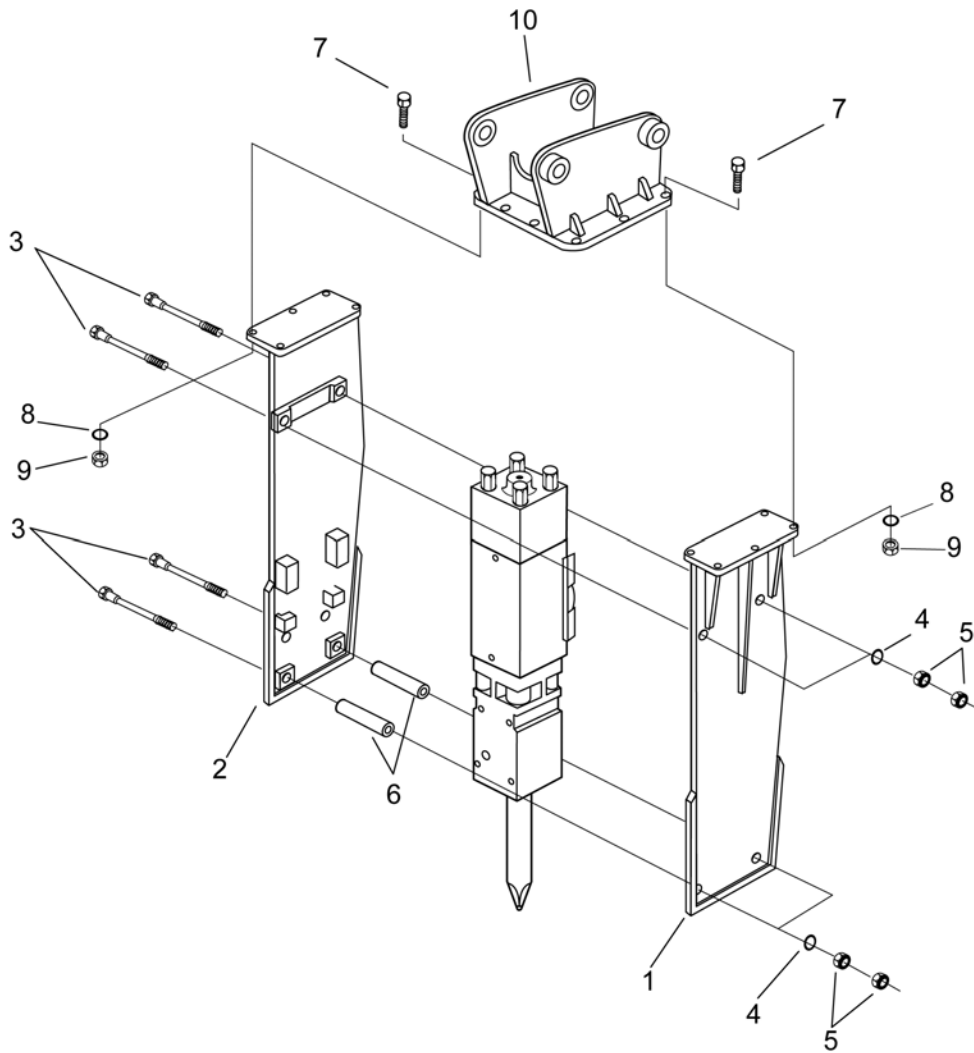

## BRACKET ASSEMBLY PARTS LIST

ITEM	PART NO.	QTY	DESCRIPTION
	MODEL HH1500		
1.	3J01-212501	1	Hammer Bracket (R)*
2.	-----	1	Hammer Bracket (L)*
3.	3H01-215502	4	Bracket Bolt
4.	Assembly of Item 3	4	Washer
5.	Assembly of Item 3	8	Nut
6.	3J01-212504	2	Support Pipe
7.	3H01-TC2000B	10	Top Cap Bolt
8.	Assembly of item 7	10	Top Cap Washer
9.	Assembly of item 7	10	Top Cap Nut
10.	Per Carrier Model	1	Top Cap

\*Sold as matched set w/ hardware

Prices subject to change without notice.

Effective 07/05



# HH2000 HAMMER UP TO S/N 2K031 SOLD BEFORE 9/96

ITEM	NAME	NUMBER	QTY.
1	Cylinder	3H01-2150001	1
2	Cylinder O-Ring*	3H01-09098B	2
3	Cylinder O-Ring*	3H01-09072B	3
4	Cylinder Sleeve	3H01-2150002	1
5	Cylinder Sleeve O-Ring*	3H01-09288W	3
6	Gas U-Packing*	3H01-U15000G	1
7	U-Packing*	3H01-U15000I	2
8	U-Packing with Back Up Ring*	3H01-15000H	2
9	Dust Seal*	3H01-15000D	1
10	Drain Plug	3Z01-DP0014	1
11	Piston	3H01-2150011	1
12	Valve Box	3H01-2150021	1
13	Main Valve	3H01-2150022	1
14	Upper Valve Cap	3H01-2150023	1
15	Valve Cap O-Ring*	3H01-07108B	1
16	Back Up Ring*	3H01-08108G	1
17	Valve Cap O-Ring*	3H01-051180	1
18	Lower Valve Cap	3H01-2150025	1
19	Locater Pin	3Z01-PN0510	1
20	Box Sleeve	3H01-2150026	1
21	O-Ring*	3H01-07118B	1
22	Back Up Ring*	3H01-08118G	1
23	Valve Box Set Bolt	3H01-B48138	6
24	Valve Cap Bolt	3H01-B44098	10
25	Valve Box O-Ring*	3H01-09040B	2
26	Back Cap	3H01-21580031	1
27	Back Cap O-Ring*	3H01-07358A	1
28	Front Cap	3H01-2150041	1
29	Front Cap Plug	3Z01-FP0038	1
30	Shank Bushing	3H01-150042	1
31	Front Cap Bushing	3H01-150043	1
32	Bushing Set Pin	3H01-150044	3
33	Bushing Spring Pin	3H01-S40108	6
34	Nipple PF—3/4in.—1.1/16in. UN	3Z03-N00002	2
35	O-Ring 1BG-30	3Z03-07068B	2
36	Side Rod Assembly	3H01-150051	4
37	Side Rod Front Nut	3H01-150052	4
38	Side Rod Back Nut	3H01-150053	4
39	Side Rod Washer	3H01-150054	4
40	Grease Nipple	3Z01-GN0018	1
41	Tool Set Pin	3H01-150061	1
42	Tool Spring Pin	3H01-S40248	2
43	Tool Moil (Chisel, Blunt)	3H01-215P(Fx, E)	1
44	Mode Valve Body	3H01-2210027	1
45	Mode Valve	3H01-2210028	1
46	Mode Valve O-Ring*	3H01-09044W	1
47	Mode Valve O-Ring*	3H01-09036W	1
48	Mode Valve Set Bolt	3H01-B32068	4
49	Mode Valve Lock Bolt	3H01-B24040	1
50	Spring Washer	3H01-SW0008	1
51	Locater Pin	3H01-PN0308	3
52	Stop Ring	3H01-SL10018	1
NI	Seal Kit	3H01-215SK	1
NI	Gas Charger	3Z01-202GC	1
NI	Mode Valve Assembly	3H01-221MVA	1
NI	Valve Box Assembly	3H01-215VBA	1
53	Gas Valve Assembly (Includes item # 54)	3Z01-G00001	1
54	Gas Valve Cap with O-Ring	3Z01-G00004	1

\*Included in seal kit only.

NI denotes not illustrated.

Effective 07/05

# HH2000 HAMMER UP TO S/N 2K031 SOLD BEFORE 9/96

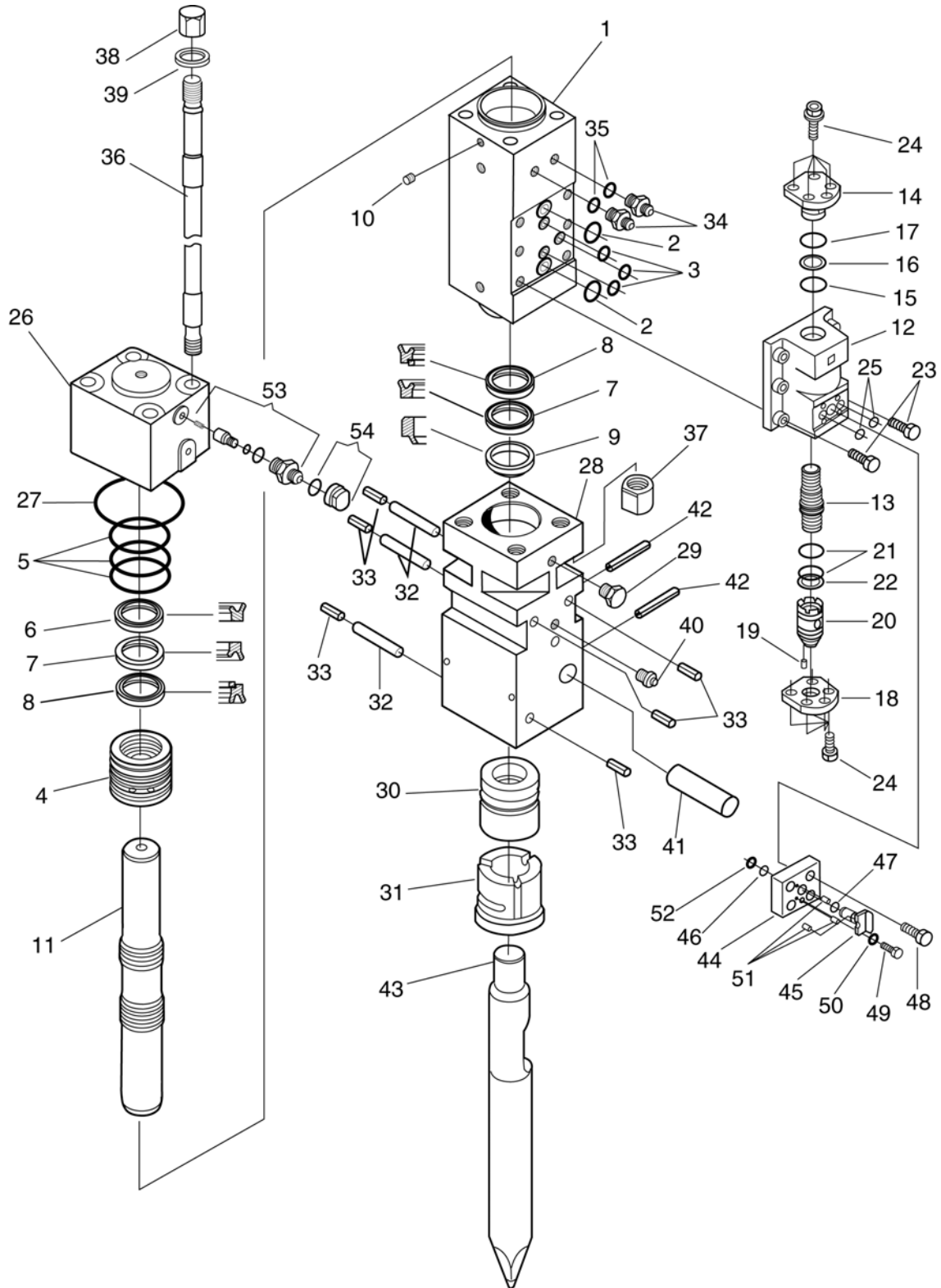

Effective 07/05

# HH2000 HAMMER S/N 3K001 & UP SOLD AFTER 10/96

ITEM	NAME	NUMBER	QTY.
1	Cylinder	3H01-2150001	1
2	Cylinder O-Ring*	3H01-09098B	2
3	Cylinder O-Ring*	3H01-09072B	3
4	Plug	3J01-2210081	5
5	Cylinder O-Ring*	3J01-09056W	10
6	Buffer Ring*	3H01-08056P	5
7	Cylinder Sleeve	3H01-2150002	1
8	Cylinder Sleeve O-Ring*	3H01-09288W	2
9	Quad Ring*	3H01-QD215000	1
10	Back Up Ring*	3H01-BU215000	1
11	Step Seal*	3H01-ST215000	2
12	Step Seal O-Ring*	3H01-OR215000	2
13	U-Packing*	3H01-U15000I	1
14	U-Packing*	3H01-15000H	1
15	Dust Seal*	3H01-15000D	1
16	Piston	3H01-2150011	1
17	Valve Box	3H01-2150021	1
18	Main Valve	3H01-2150022	1
19	Upper Valve Cap	3H01-2150023	1
20	Valve Cap O-Ring*	3H01-07108B	1
21	Back Up Ring*	3H01-08108G	1
22	Valve Cap O-Ring*	3H01-051180	1
23	Lower Valve Cap	3H01-2150025	1
24	Locater Pin	3Z01-PN0510	1
25	Box Sleeve	3H01-2150026	1
26	Box Sleeve O-Ring*	3H01-07118B	2
27	Back Up Ring*	3H01-08118G	1
28	Valve Cap Bolt	3H01-B44098	10
29	Valve Box Set Bolt	3H01-B48138	6
30	Mode Valve Body	3H01-2210027	1
31	Mode Valve	3H01-2210028	1
32	Mode Valve O-Ring*	3H01-09044W	1
33	Mode Valve O-Ring*	3H01-09036W	1
34	Mode Valve Set Bolt	3H01-B32068	4
35	Mode Valve Lock Bolt	3H01-B24040	1
36	Spring Washer	3H01-SW0008	1
37	Locater Pin	3Z01-PN0510	3
38	Stop Ring	3H01-SL0018	1
39	Valve Box O-Ring*	3H01-09040B	2
40	Back Cap	3H01-21580031	1
41	Back Cap O-Ring*	3H01-07358A	1
42	Gas Valve Assembly (Includes item # 43)	3Z01-G00001	1
43	Gas Valve Cap with O-Ring	3Z01-G00004	1
44	Front Cap	3H01-2150041	1
45	Front Cap Plug	3Z01-FP0038	1
46	Shank Bushing	3H01-150042	1
47	Front Bushing	3H01-150043	1
48	Bushing Set Pin	3H01-150044	3
49	Bushing Spring Pin	3H01-S40108	6
50	Nipple PF—3/4in.—1.1/16in. UN	3Z03-N00002	2
51	O-Ring 1BG-30	3Z03-07068B	2
52	Side Rod Assembly	3H01-150051	4
53	Side Rod Front Nut	3H01-150052	4
54	Side Rod Back Nut	3H01-150053	4
55	Side Rod Washer	3H01-150054	4
56	Grease Nipple	3Z01-GN0018	1
57	Tool Set Pin	3H01-150061	1
58	Tool Spring Pin	3H01-S40248	1
59	Tool Moil (Chisel, Blunt)	3H01-215P(Fx, E)	1
NI	Seal Kit	3H01-215SKX	1
NI	Gas Charger	3Z01-202GC	1
NI	Mode Valve Assembly	3H01-221MVA	1
NI	Valve Box Assembly	3H01-215VBA	1

\*Included in seal kit only. NI denotes not illustrated. Effective 07/05



# HH2000 HAMMER S/N 3K001 & UP SOLD AFTER 10/96

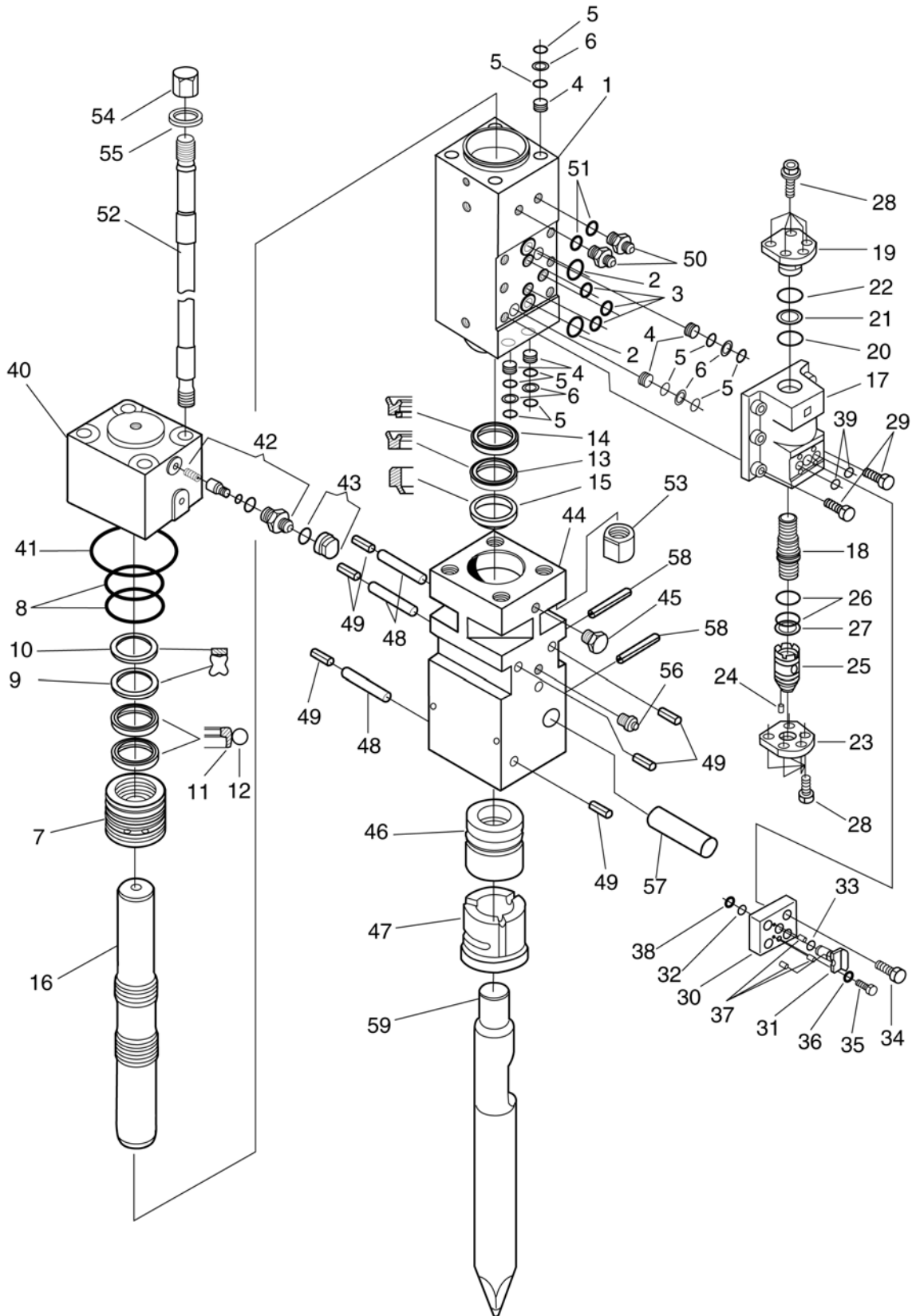

Effective 07/05

# HH2000 HAMMER

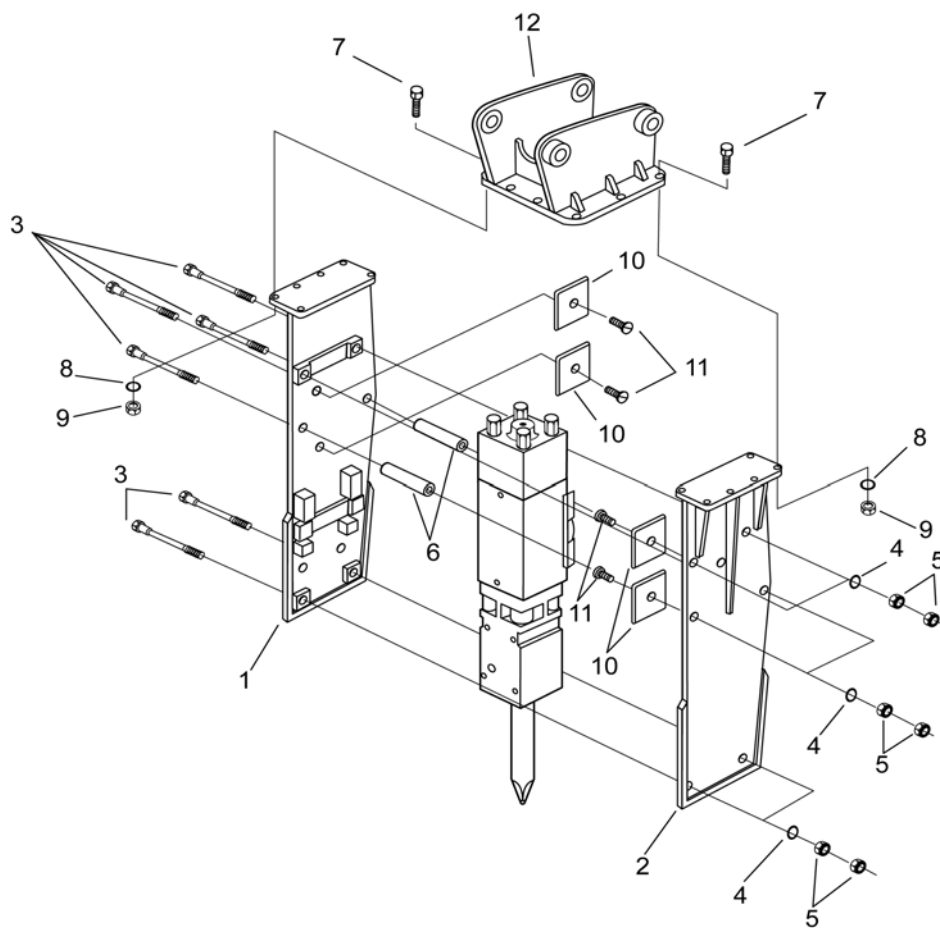

## BRACKET ASSEMBLY PARTS LIST

ITEM	PART NO.	QTY	DESCRIPTION
	MODEL HH2000		
1.	3H01-215501	1	Hammer Bracket (R)*
2.	—————	1	Hammer Bracket (L)*
3.	3H01-215502	6	Bracket Bolt
4.	Assembly of Item 3	6	Washer
5.	Assembly of Item 3	12	Nut
NI	3H01-215504-198	2	Support Pipe (Top)
6.	3H01-215505-262	2	Support Pipe (Middle)
NI	3H01-215506-162	2	Support Pipe (Bottom)
7.	3H01-TC2000B	10	Top Cap Bolt
8.	Assembly of Item 8	10	Top Cap Washer
9.	Assembly of Item 8	10	Top Cap Nut
10.	3H01-215505	4	Cushion Rubber
11.	Assembly of Item 10	4	Screw
12.	Per Carrier Model	1	Top Cap

\*Sold as matched set w/ hardware. NI denotes not illustrated. Effective 07/05  
 Prices subject to change without notice.



# HH3600-2 HAMMER

# S/N 5M1000 & UP

ITEM	NAME	NUMBER	QTY.
1	Cylinder	3J01-B2210001-2	1
2	Cylinder O-Ring*	3J01-09108B	3
3	Cylinder O-Ring*	3H01-09072B	4
4	Cylinder Sleeve	3J01-2210002-2	1
5	Cylinder Sleeve O-Ring*	3J01-07328W	2
6	Step Seal with O-Ring*	3J01-170561	2
7	Quad Ring*	3J01-QD221000	1
8	Back Up Ring*	3J01-170563	2
9	U-Packing*	3J01-U21000I	2
10	Dust Seal*	3J01-D21000D	1
11	Piston	3J01-2210011-2	1
12	Valve Box	3J01-2210021-2	1
13	Main Valve	3J01-2210022-2	1
14	Upper Valve Cap	3J01-2210023	1
15	Valve Cap O-Ring*	3H01-07118B	1
16	Back Up Ring*	3H01-08118G	1
17	Valve Cap O-Ring*	3J01-051280	1
18	Lower Valve Cap	3J01-2210025-2	1
19	Locater Pin	3Z01-PN0510	1
20	Box Sleeve	3J01-2210026-2	1
21	Box Sleeve O-Ring*	3J01-07128B	2
22	Back Up Ring*	3J01-08128G	1
23	Valve Box Set Bolt	3J01-B52146	6
24	Valve Cap Bolt	3J01-B52128	10
25	Valve Box O-Ring*	3H01-09040B	2
26	Back Cap	3J01-2210031	1
27	Back Cap O-Ring*	3J01-07398A	1
28	Plug	3J01-240081	2
29	Cylinder O-Ring*	3J01-09076W	4
30	Buffer Ring*	3J01-08076P	2
31	Valve Box Plug	3J01-2212095	1
32	Valve Box O-Ring*	3J01-09056W	1
33	Front Cap	3J01-2210041-2	1
34	Front Cap Plug	3Z01-FP0038	1
35	Shank Bushing	3J01-2210042	1
36	Front Cap Bushing	3J01-210043	1
37	Bushing Set Pin	3J01-210044	3
38	Bushing Spring Pin	3J01-S46128	6
39	Nipple PF—3/4in.—1.1/16in. UN	3J01-N00003	2
40	O Ring	3J01-07078B	2
41	Side Rod Assembly	3J01-210051	4
42	Side Rod Front Nut	3J01-210052	4
43	Side Rod Back Nut	3J01-210053	4
44	Side Rod Washer	3J01-210054	4
45	Grease Nipple	3Z01-GN0018	1
46	Tool Stopper Pin	3J01-221091	2
47	Tool Spring Pin	3J01-S46128	2
48	Tool Set Pin	3J01-210061	1
49	Tool Moil (Chisel, Blunt)	3J01-221P(Fx, E)	1
50	Mode Valve Body	3H01-2210027	1
51	Mode Valve	3H01-2210028	1
52	Mode Valve O-Ring*	3H01-09044W	1
53	Mode Valve O-Ring*	3H01-09036W	1
54	Mode Valve Set Bolt	3H01-B32068	4
55	Mode Valve Lock Bolt	3H01-B24040	1
56	Spring Washer	3H01-SW0008	1
57	Locater Pin	3H01-PN0308	3
58	Stop Ring	3H01-SL0018	1
NI	Mode Valve Assembly	3H01-221MVA	1
NI	Valve Box Assembly	3J01-221VBA	1
NI	Seal Kit	3J01-221SK	1
NI	Gas Charger	3Z01-202GC	1
59	Gas Valve Assembly (Includes item # 60)	3Z01-G00001	1
60	Gas Valve Cap with O-Ring	3Z01-G00004	1

\*Included in seal kit only.

NI denotes not illustrated.

Effective 07/05



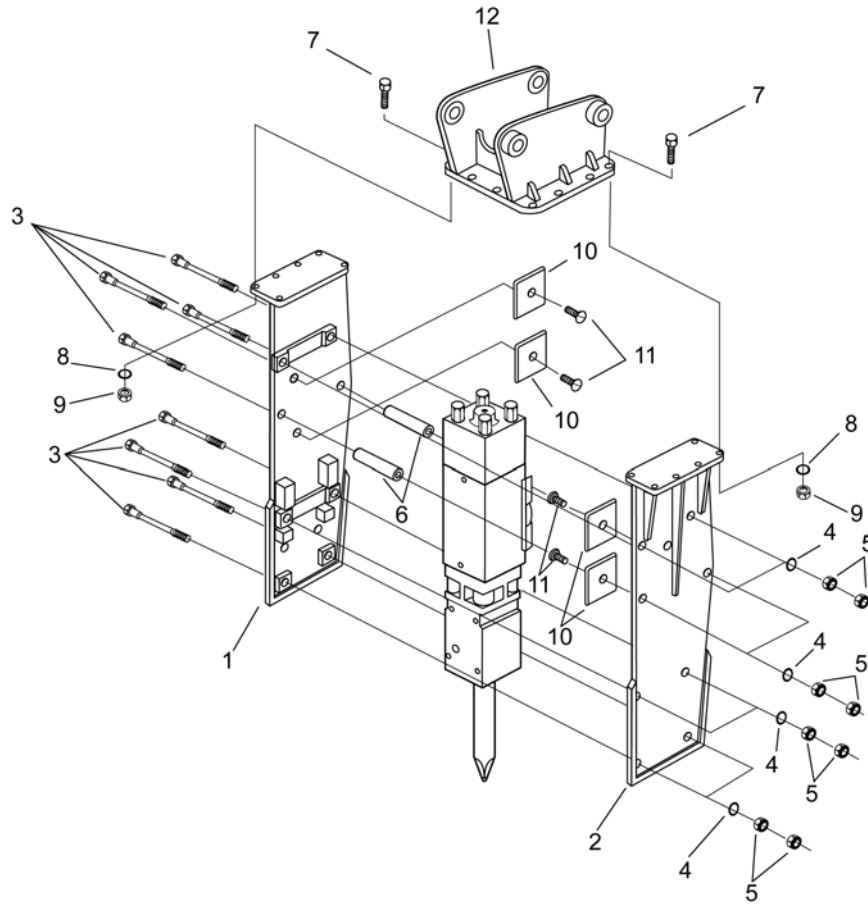

### BRACKET ASSEMBLY PARTS LIST

ITEM	PART NO.	QTY	DESCRIPTION
	MODEL HH3600-2		
1.	3J01-221501	1	Hammer Bracket (R)*
2.	_____	1	Hammer Bracket (L)*
3.	3J01-221502	8	Bracket Bolt
4.	Assembly of Item 3	8	Washer
5.	Assembly of Item 3	16	Nut
NI	3J01-221504-226	2	Support Pipe (Top)
6.	3J01-221507-298	2	Support Pipe (Middle)
NI	3J01-221506-234	4	Support Pipe (Bottom)
7.	3J01-TC3600B	12	Top Cap Bolt
8.	Assembly of Item 7	12	Top Cap Washer
9.	Assembly of Item 7	12	Top Cap Nut
10.	3J01-221505	4	Cushion Rubber
11.	Assembly of Item 10	4	Screw
12.	Per Carrier Model	1	Top Cap

\*Sold as matched set w/ hardware. NI denotes not illustrated.

Effective 07/05

Prices subject to change without notice



# HH4500 HAMMER

ITEM	NAME	NUMBER	QTY.
1	Cylinder	3K01-2270001	1
2	Cylinder O-Ring*	3K01-09128B	2
3	Cylinder O-Ring*	3H01-09072B	3
4	Cylinder Sleeve	3K01-2270002	1
5	Cylinder Sleeve O-Ring*	3K01-07348W	2
6	Quad Ring*	3K01-170570	1
7	Back Up Ring*	3K01-170573	2
8	U-Packing*	3K01-U270001	1
9	U-Packing with Back Up Ring*	3K01-U27000H	1
10	Dust Seal*	3K01-D27000D	1
11	Step Seal with O-Ring*	3K01-170571	2
12	Piston	3K01-2270011	1
13	Valve Box	3K01-2270021	1
14	Main Valve	3K01-2270022	1
15	Upper Valve Cap	3K01-2270023	1
16	Valve Cap O-Ring*	3H01-07118B	1
17	Back Up Ring*	3H01-08118G	1
18	Valve Cap O-Ring*	3J01-051280	1
19	Lower Valve Cap	3K01-2270025	1
20	Locater Pin	3Z01-PN0510	1
21	Box Sleeve	3K01-2270026	1
22	Box Sleeve O-Ring*	3K01-07138B	2
23	Back Up Ring*	3K01-08138G	1
24	Valve Box Set Bolt	3J01-B52146	8
25	Valve Cap Bolt	3J01-B52128	10
26	Valve Box O-Ring*	3H01-09040B	2
27	Back Cap	3K01-2270031	1
28	Back Cap O-Ring*	3K01-09418A	1
29	Plug	3K01-22182	4
30	Cylinder O-Ring*	3K01-9066W	8
31	Buffer Ring*	3K01-8066P	4
32	Front Cap	3K01-2210041	1
33	Front Cap Plug	3Z01-FP0038	1
34	Shank Bushing	3K01-2270042	1
35	Front Cap Bushing	3K01-270043	1
36	Bushing Set Pin	3K01-270044	3
37	Bushing Spring Pin	3J01-S46128	6
38	Nipple	3J03-N00003	2
39	O-Ring	3J03-07078B	2
40	Side Rod Assembly	3K01-270051	4
41	Side Rod Front Nut	3K01-270052	4
42	Side Rod Back Nut	3K01-270053	4
43	Side Rod Washer	3K01-270054	4
44	Grease Nipple	3Z01-GN0018	1
45	Tool Set Pin	3K01-270061	1
46	Tool Spring Pin	3J01-S46128	2
47	Tool Stopper Pin	3K01-227091	2
48	Tool Moil (Chisel, Blunt)	3K01-227P(Fx, E)	1
49	Mode Valve Body	3H01-2210027	1
50	Mode Valve	3H01-2210028	1
51	Mode Valve O-Ring*	3H01-09044W	1
52	Mode Valve O-Ring*	3H01-09036W	1
53	Mode Valve Set Bolt	3H01-B32068	4
54	Mode Valve Lock Bolt	3H01-B24040	1
55	Spring Washer	3H01-SW0008	1
56	Locater Pin	3H01-PN0308	3
57	Stop Ring	3H01-SL0018	1
NI	Mode Valve Assembly	3H01-221MVA	1
NI	Valve Box Assembly	3K01-227VBA	1
NI	Seal Kit	3K01-227SK	1
NI	Gas Charger	3Z01-202GC	1
58	Gas Valve Assembly (Includes item # 59)	3Z01-G00001	1
59	Gas Valve Cap with O-Ring	3Z01-G00004	1

\*Included in seal kit only. NI denotes not illustrated.

Effective 07/05



# HH4500 HAMMER

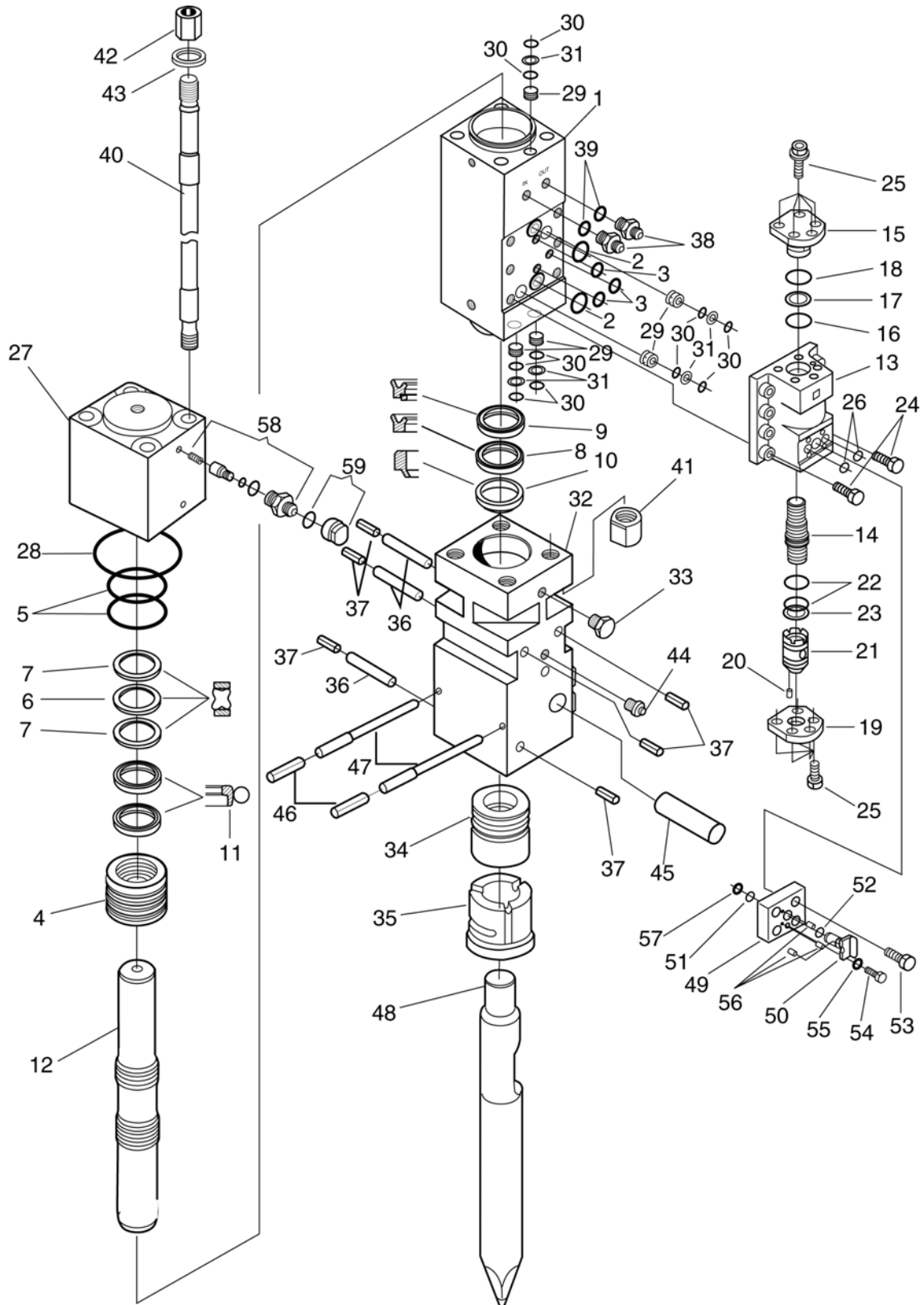

Effective 07/05

# HH4500 HAMMER

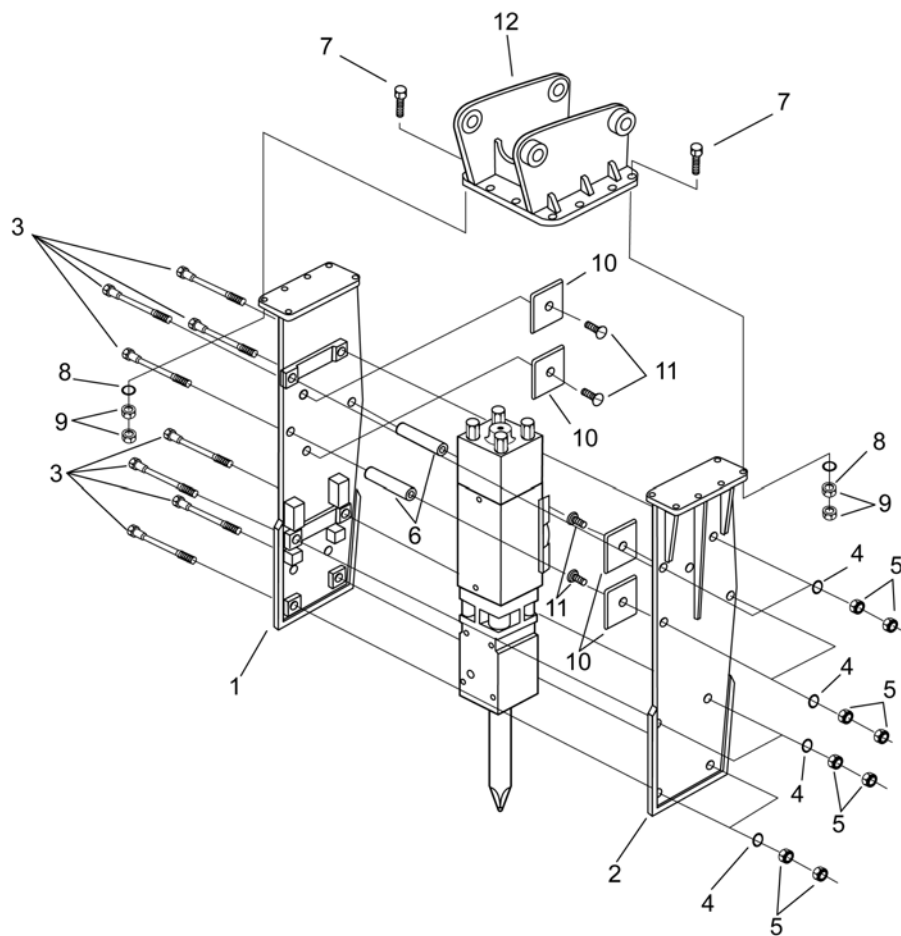

## BRACKET ASSEMBLY PARTS LIST

ITEM	PART NO.	QTY	DESCRIPTION
	MODEL HH4500		
1.	3K01-227501	1	Hammer Bracket (R)*
2.	_____	1	Hammer Bracket (L)*
3.	3K01-227502	8	Bracket Bolt
4.	Assembly of Item 3	8	Washer
5.	Assembly of Item 3	16	Nut
NI	3K01-227504-262	2	Support Pipe (Top)
6.	3K01-227507-334	2	Support Pipe (Middle)
NI	3K01-227504-262	4	Support Pipe (Bottom)
7.	3J01-TC3600B	12	Top Cap Bolt
8.	Assembly of Item 7	12	Top Cap Washer
9.	Assembly of Item 7	12	Top Cap Nut
10.	3K01-227505	4	Cushion Rubber
11.	Assembly of Item 10	4	Screw
12.	Per Carrier Model	1	Top Cap

\*Sold as matched set w/ hardware. NI denotes not illustrated.

Effective 07/05

Prices subject to change without notice.



# HH5800 HAMMER

ITEM	NAME	NUMBER	QTY.
1	Cylinder	3L01-2330001	1
2	Cylinder O-Ring*	3J01-09108B	1
3	Cylinder O-Ring*	3J01-09138B	2
4	Cylinder O-Ring*	3H01-09072B	2
5	Cylinder Sleeve	3L01-2330002	1
6	Cylinder Sleeve O-Ring*	3L01-07378W	2
7	Quad Ring*	3L01-170580	1
8	Back Up Ring*	3L01-170583	2
9	Step Seal with O-Ring*	3L01-170581	2
10	U-Packing*	3L01-U330001	1
11	U-Packing with Back Up Ring*	3L01-U33000H	1
12	Dust Seal*	3L01-D33000D	1
13	Piston	3L01-2330011	1
14	Valve Box	3L01-2330021	1
15	Main Valve	3L01-2330022	1
16	Upper Valve Cap	3L01-2330023	1
17	Valve Cap O-Ring*	3K01-07138B	1
18	Back Up Ring*	3K01-08138G	1
19	Valve Cap O-Ring*	3L01-051480	1
20	Lower Valve Cap	3L01-2330025	1
21	Locator Pin	3Z01-PN0510	1
22	Box Sleeve	3L01-2330026	1
23	Box Sleeve O-Ring*	3L01-07148B	2
24	Back Up Ring*	3L01-08148G	1
25	Valve Box Set Bolt	3L01-B62154	8
26	Valve Cap Bolt	3L01-B56144	10
27	Valve Box O-Ring*	3H01-09040B	2
28	Back Cap	3L01-2330031	1
29	Back Cap O-Ring*	3L01-09468A	1
30	Plug	3K01-2210082	6
31	Cylinder O-Ring*	3K01-09066W	12
32	Buffer Ring*	3K01-08066P	6
33	Front Cap	3L01-2330041	1
34	Front Cap Plug	3Z01-FP0038	1
35	Shank Bushing	3L01-2330042	1
36	Front Cap Bushing	3L01-330043	1
37	Bushing Set Pin	3L01-330044	4
38	Bushing Spring Pin	3L01-S52168	8
39	Nipple	3J03-N00003	2
40	O-Ring	3J03-07078B	2
41	Side Rod Assembly	3L01-230051	4
42	Side Rod Front Nut	3L01-2330052	4
43	Side Rod Back Nut	3L01-2330053	4
44	Side Rod Washer.	3L01-2330054	4
45	Grease Nipple	3Z01-GN0018	1
46	Tool Set Pin	3L01-330061	1
47	Tool Spring Pin	3L01-S52368	2
48	Tool Moil (Chisel, Blunt)	3L01-233P(Fx, E)	1
49	Mode Valve Body	3H01-2210027	1
50	Mode Valve	3H01-2210028	1
51	Mode Valve O-Ring*	3H01-09044W	1
52	Mode Valve O-Ring*	3H01-09036W	1
53	Mode Valve Set Bolt	3H01-B32068	4
54	Mode Valve Lock Bolt	3H01-B24040	1
55	Spring Washer	3H01-SW0008	1
56	Locator Pin	3H01-PN0308	3
57	Stop Ring	3H01-SL0018	1
NI	Mode Valve Assembly	3H01-221MVA	1
NI	Valve Box Assembly	3L01-233VBA	1
NI	Seal Kit	3L01-233SK	1
NI	Gas Charger	3Z01-202GC	1
58	Gas Valve Assembly (Includes item # 59)	3Z01-G00001	1
59	Gas Valve Cap with O-Ring	3Z01-G00004	1

\*Included in seal kit only. NI denotes not illustrated.

Effective 07/05

# HH5800 HAMMER

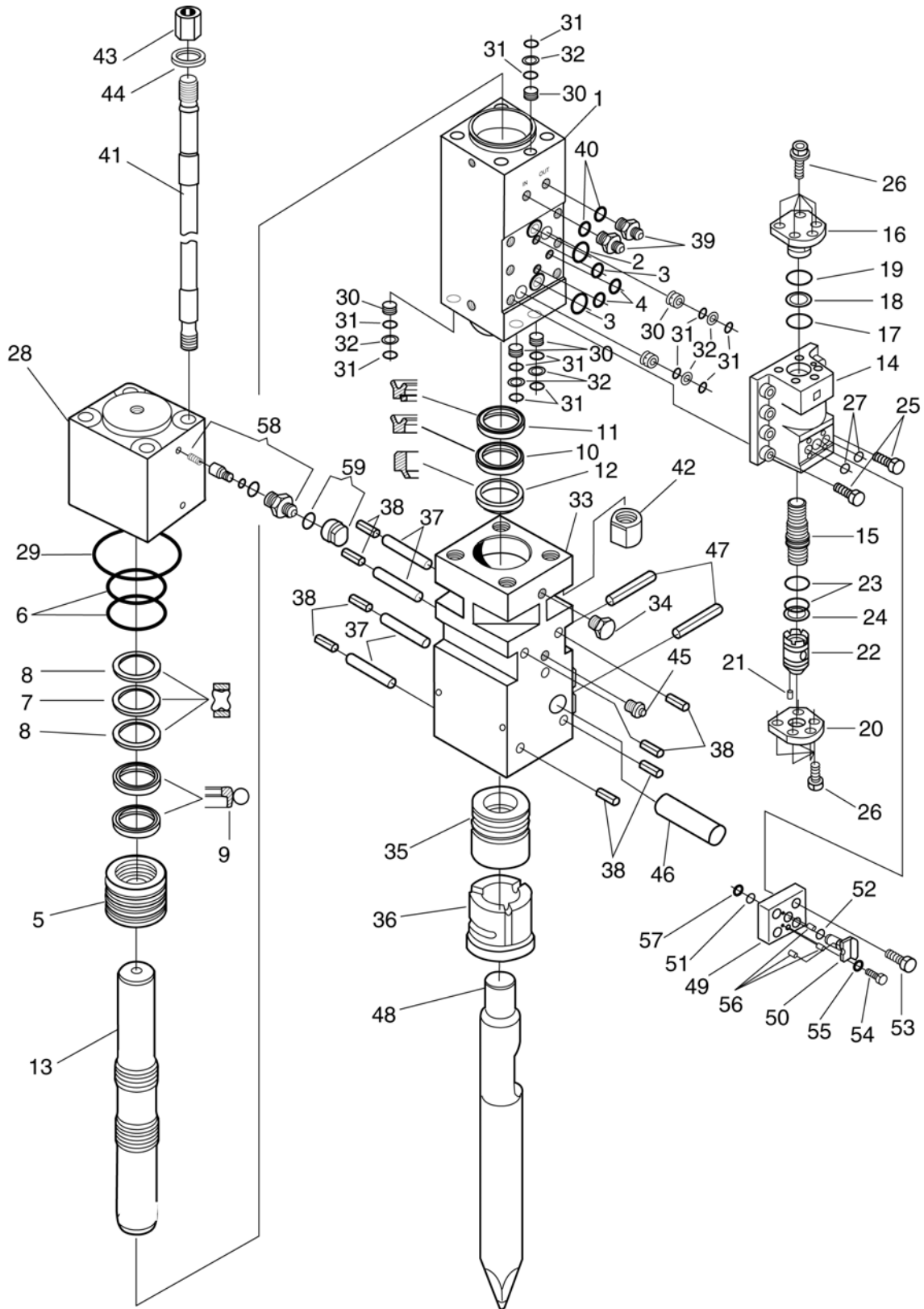

Effective 07/05

# HH5800 HAMMER

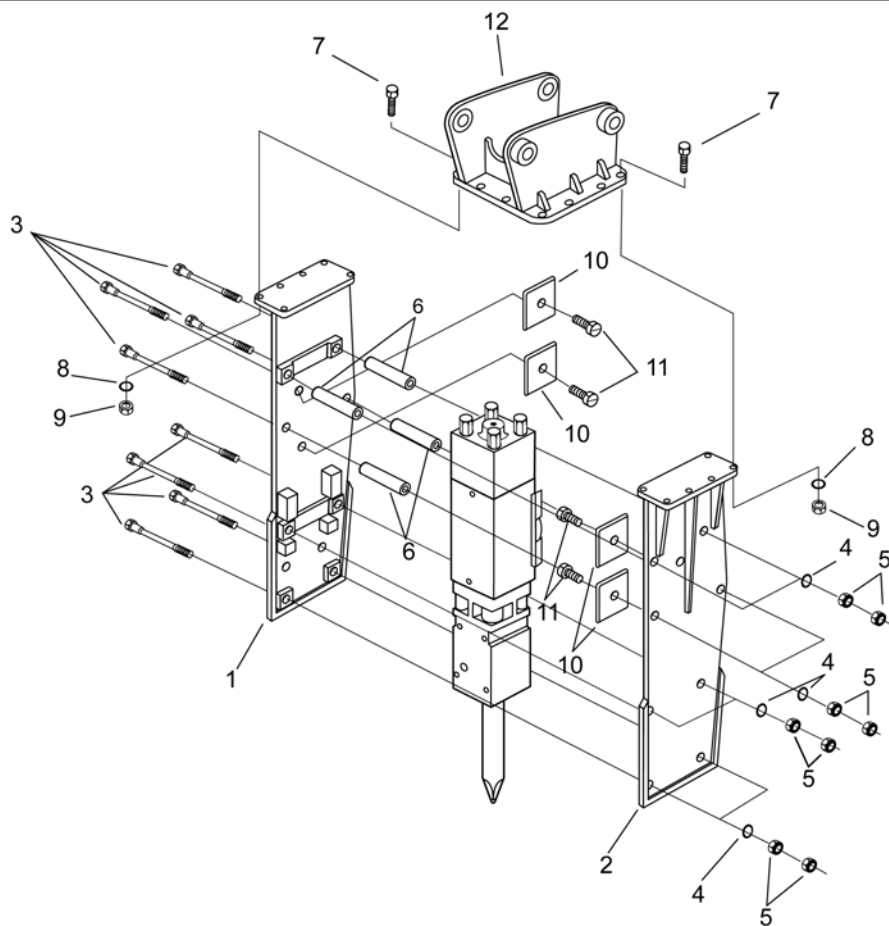

## BRACKET ASSEMBLY PARTS LIST

ITEM	PART NO.	QTY	DESCRIPTION
	MODEL HH5800		
1.	3L01-233501	1	Hammer Bracket (R)*
2.	_____	1	Hammer Bracket (L)*
3.	3L01-233502	8	Bracket Bolt
4.	Assembly of Item 3	8	Washer
5.	Assembly of Item 3	16	Nut
NI	3L01-233504-284	2	Support Pipe (Top)
6.	3L01-233507-364	2	Support Pipe (Middle)
NI	3L01-233504-284	4	Support Pipe (Bottom)
7.	3J01-TC3600B	12	Top Cap Bolt
8.	Assembly of Item 7	12	Top Cap Washer
9.	Assembly of Item 7	12	Top Cap Nut
10.	3L01-233505	4	Cushion Rubber
11.	Assembly of Item 10	4	Screw
12.	Per Carrier Model	1	Top Cap

\*Sold as matched set w/ hardware. NI denotes not illustrated. Effective 07/05  
 Prices subject to change without notice.



# HH8000 HAMMER

ITEM	NAME	NUMBER	QTY.
1	Cylinder	3M01-2400001	1
2	Cylinder O-Ring*	3L01-09138B	2
3	Cylinder O-Ring*	3M01-09098B	1
4	Cylinder O-Ring*	3H01-09072B	2
5	Cylinder Sleeve	3M01-2400002	1
6	Cylinder Sleeve O-Ring*	3M01-07398W	2
7	Quad Ring*	3M01-170590	1
8	Back Up Ring*	3M01-170593	2
9	Step Seal with O-Ring*	3M01-170591	2
10	U-Packing*	3M01-U400001	1
11	U-Packing with Back Up Ring*	3M01-U40000H	1
12	Dust Seal*	3M01-D40000D	1
13	Piston	3M01-2400011	1
14	Valve Box	3M01-2400021	1
15	Main Valve	3M01-2400022	1
16	Upper Valve Cap	3M01-2400023	1
17	Valve Cap O-Ring*	3K01-07138B	1
18	Back Up Ring*	3K01-08138G	1
19	Valve Cap O-Ring*	3M01-051480	1
20	Lower Valve Cap	3M01-2400025	1
21	Locater Pin	3Z01-PN0510	1
22	Box Sleeve	3M01-2400026	1
23	Box Sleeve O-Ring*	3M01-07158B	2
24	Back Up Ring*	3M01-08158G	1
25	Valve Box Set Bolt	3L01-B62154	2
26	Valve Cap Bolt	3L01-B56144	10
27	Valve Box O-Ring*	3H01-09040B	2
28	Back Cap	3M01-2400031	1
29	Back Cap O-Ring*	3M01-09488A	1
30	Plug	3J01-240081	5
31	Cylinder O-Ring*	3J01-09076W	10
32	Buffer Ring*	3J01-08076P	5
33	Front Cap	3M01-2400041	1
34	Front Cap Plug	3Z01-FP0038	1
35	Shank Bushing	3M01-2400042	1
36	Front Cap Bushing	3M01-2400043	1
37	Bushing Set Pin	3M01-2400044	4
38	Bushing Spring Pin	3L01-S52168	8
39	Nipple	3M03-N00004	2
40	O-Ring	3M03-07098B	2
41	Side Rod Assembly	3M01-2400051	4
42	Side Rod Front Nut	3M01-2400052	4
43	Side Rod Back Nut	3M01-2400053	4
44	Side Rod Washer.	3M01-2400054	4
45	Grease Nipple	3Z01-GN0018	1
46	Tool Set Pin	3M01-400061	1
47	Tool Spring Pin	3L01-S52368	2
48	Tool Moil (Chisel, Blunt)	3M01-240P(Fx, E)	1
49	Mode Valve Body	3H01-2210027	1
50	Mode Valve	3H01-2210028	1
51	Mode Valve O-Ring*	3H01-09044W	1
52	Mode Valve O-Ring*	3H01-09036W	1
53	Mode Valve Set Bolt	3H01-B32068	4
54	Mode Valve Lock Bolt	3H01-B24040	1
55	Spring Washer	3H01-SW0008	1
56	Locater Pin	3H01-PN0308	3
57	Stop Ring	3H01-SL0018	1
NI	Mode Valve Assembly	3H01-221MVA	1
NI	Valve Box Assembly	3M01-240VBA	1
NI	Seal Kit	3M01-240SK	1
NI	Gas Charger	3Z01-202GC	1
58	Gas Valve Assembly (Includes item # 59)	3Z01-G00001	1
59	Gas Valve Cap with O-Ring	3Z01-G00004	1

\*Included in seal kit only.

NI denotes not illustrated.

Effective 07/05



# HH8000 HAMMER

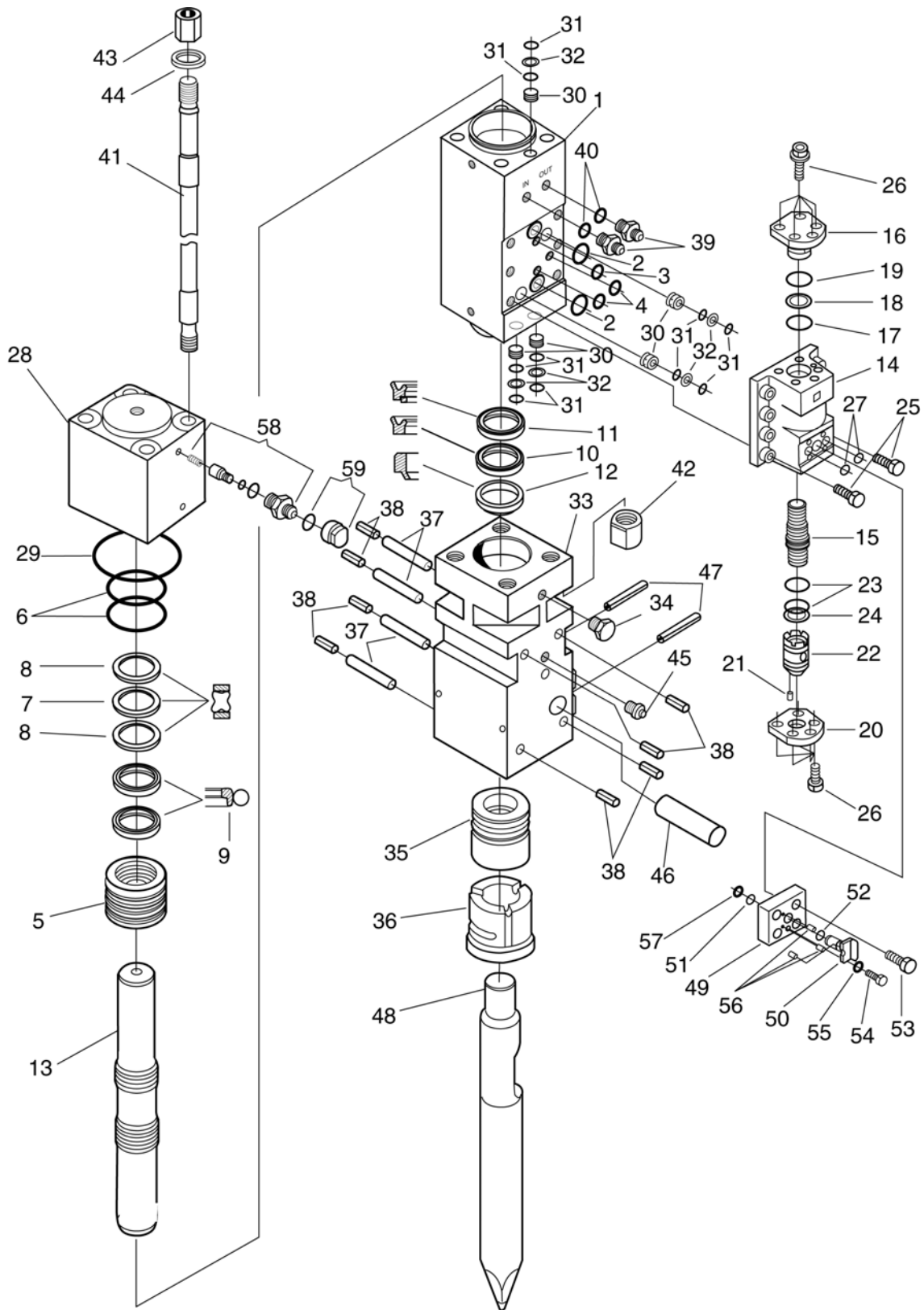

Effective 07/05

# HH8000 HAMMER

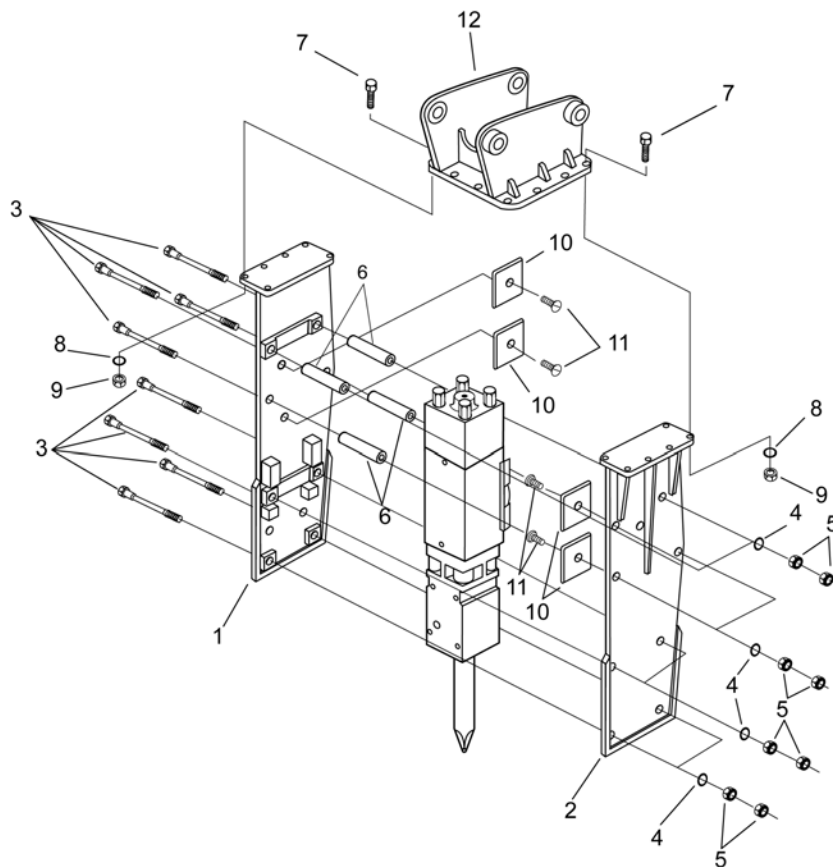

## BRACKET ASSEMBLY PARTS LIST

ITEM	PART NO.	QTY	DESCRIPTION
	MODEL HH8000		
1.	3M01-240501	1	Hammer Bracket (R)*
2.	—————	1	Hammer Bracket (L)*
3.	3M01-240502	8	Bracket Bolt
4.	Assembly of Item 3	8	Washer
5.	Assembly of Item 3	16	Nut
NI	3M01-240504-304	2	Support Pipe (Top)
6.	3M01-240507-384	2	Support Pipe (Middle)
NI	3M01-240504-304	4	Support Pipe (Bottom)
7.	3M01-TC8000B	12	Top Cap Bolt
8.	Assembly of Item 7	12	Top Cap Washer
9.	Assembly of Item 7	12	Top Cap Nut
10.	3M01-240505	4	Cushion Rubber
11.	Assembly of Item 10	4	Screw
12.	Per Carrier Model	1	Top Cap

\*Sold as matched set w/ hardware. NI denotes not illustrated.

Effective 07/05

Prices subject to change without notice.





## **HYDRAULIC HAMMERS**

**IPC INDUSTRIES, INC.**

**194 N. Brandon Dr.**

**Glendale Heights, IL 60139**

**TOLL FREE (800) 487-5431**

**Phone: (630) 893-5558 Fax: (630) 790-3751**

rev: 7/05

## Free Manuals Download Website

<http://myh66.com>

<http://usermanuals.us>

<http://www.somanuals.com>

<http://www.4manuals.cc>

<http://www.manual-lib.com>

<http://www.404manual.com>

<http://www.luxmanual.com>

<http://aubethermostatmanual.com>

Golf course search by state

<http://golfingnear.com>

Email search by domain

<http://emailbydomain.com>

Auto manuals search

<http://auto.somanuals.com>

TV manuals search

<http://tv.somanuals.com>