

# ***Hustler ATZ Parts Manual***



**HUSTLER®**



*Hustler Turf Equipment*



*P.O. Box 7000*



*Hesston, Kansas*



*67062-2097*



---

# Table of Contents

<b>Chapter 1</b>	
General Information . . . . .	1-1
<b>Chapter 2</b>	
Rivet Nut Installation . . . . .	2-2
Footrest Assembly . . . . .	2-3
<b>Chapter 3</b>	
Hydraulic System Installation—Kawasaki 31 HP HT Engine . . . . .	3-2
<b>Chapter 4</b>	
Battery Installation. . . . .	4-2
Deck Lift Assembly . . . . .	4-4
Park Brake Assembly . . . . .	4-6
Steering Assembly . . . . .	4-8
Steering Sub-Assembly. . . . .	4-10
Pump Belt and Pulleys Installation . . . . .	4-12
<b>Chapter 5</b>	
Kawasaki 31 HP Engine Installation . . . . .	5-2
Fuel System Installation . . . . .	5-4
Instrument Panel Assembly/Installation . . . . .	5-6
Electrical Schematic - Kawasaki (601555) . . . . .	5-8
<b>Chapter 6</b>	
Front Wheel Assembly . . . . .	6-2
Semi-Pneumatic Tire/Wheel—789537 . . . . .	6-4
Drive Wheel Assembly Installation . . . . .	6-5
Anti-Rollover Wheel Assembly . . . . .	6-6
<b>Chapter 7</b>	
Weight Installation. . . . .	7-2
ROPS Installation . . . . .	7-4
<b>Chapter 8</b>	
72" Side Discharge Deck Assembly (XR7) . . . . .	8-2
72" Side Discharge Deck Pulley Assembly (XR7) . . . . .	8-4
60" Side Discharge Deck Assembly . . . . .	8-6
60" Side Discharge Deck Pulley Assembly (XR7) . . . . .	8-8
Side Discharge Deck—"A" Adaptors. . . . .	8-10
60" Rear Discharge Deck Assembly . . . . .	8-12
60" Rear Discharge Deck Pulley Assembly . . . . .	8-14
Spindle Assembly—796235 . . . . .	8-16
Spindle Assembly—796680 . . . . .	8-17
<b>Chapter 9</b>	
Deck Installation . . . . .	9-2
72" Side Discharge Belt Routing and Tensioning . . . . .	9-4
60" Side Discharge Belt Routing and Tensioning . . . . .	9-5
60" Rear Discharge Belt Routing and Tensioning. . . . .	9-6

---

**Chapter 10**

Tractor Decals .....	10-2
72" & 60" Side Discharge Deck Decals(XR7).....	10-4
60" Rear Discharge Deck Decals.....	10-5

**Chapter 11**

Seat Installation .....	11-2
-------------------------	------

**Chapter 12**

Adjustment .....	12-22
------------------	-------

Index.....	i-1
------------	-----

# Chapter 1

## **General Information**

This Manual covers Hustler ATZ model **928143**, Hustler ATZ model **928150** & Hustler ATZ model **928168**

---

## **Frequently Ordered Parts**

<b>PART NO.</b>	<b>DESCRIPTION</b>
783936	FILTER ELEMENT
781443	PUMP DRIVE BELT
784207	B-SECTION BELT, 72" SIDE DISCHARGE DECK
797720	B-SECTION BELT, 60" SIDE DISCHARGE DECK
795781	B-SECTION BELT, 60" REAR DISCHARGE DECK
068478	FUEL FILTER
601652	MAIN AIR FILTER ELEMENT
601653	SAFETY AIR FILTER ELEMENT
772079	KAWASAKI ENGINE OIL FILTER
798702	BLADE, F24.50"-H-F-CW, 72" SIDE DISCHARGE DECK
794685	BLADE, F20.50"-H-F-CW, 60" SIDE DISCHARGE DECK
600901	BLADE, F20.50"-L-F-CW, 60" REAR DISCHARGE DECK
795633	BLADE, F20.50"-L-F-CCW, 60" REAR DISCHARGE DECK

---

## **Service Literature**

<b>PART NO.</b>	<b>DESCRIPTION</b>
601656	ATZ OWNER'S MANUAL
601615	KAWASAKI ENGINE MANUAL

---

*Note: When ordering parts, you must use the part number as shown for each part, not the item number. Always give the model and serial number to your parts and service representative.*

*Note: Items sold in bulk such as seals and hoses are sold by the foot.*

---

## **Using this manual**

Illustrations used were current at the time of printing, but subsequent production changes may cause your machine to vary slightly in detail. Excel Industries, Inc. reserves the right to redesign and change the machine as deemed necessary, without notification. If a change has been made to your machine which is not reflected in this parts manual, see your Hustler dealer for current information and parts.

## **Hardware Description Codes & Abbreviations**

The following codes are used throughout this parts manual. Refer to this list when ordering parts.

<b>ABBREVIATION</b>	<b>DESCRIPTION</b>
CB	Carriage Bolt
CE	Clevis Pin
CP	Cotter Pin
CS	Cap Screw
CW	Cup Washer
FDRW	Fender Washer
FW	Flat Washer
HX	Hex Head
LW	Lock Washer
MB	Machine Bushing
MS	Machine Screw
NT	Nut
SC	Self Tapping Cap Screw
SH	Socket Head
SB	Shoulder Bolt
SS	Set Screw
OD	Outside Diameter
ID	Inside Diameter

---

## **Standard Torques**

The following chart lists the standard torque values for the threaded fasteners found in this manual. Torque all cap screws, nuts and set screws to these values unless a different torque is shown in the Notes section next to the fastener

<b>SIZE</b>	<b>FT-LBS</b>	<b>NM</b>	<b>SIZE</b>	<b>FT-LBS</b>	<b>NM</b>
.250	8.2	11.1	M3	1	1.3
.312	17	23	M4	2.2	3
.375	30	40	M5	4.5	6.1
.438	48	65	M6	7.7	10.4
.500	73	99	M8	18.5	25
.562	105	143	M10	37	50
.625	145	200	M12	64	87
.750	260	350	M16	160	215
.875	420	565	M20	320	435
1.00	625	850	M24	555	750

---

### **NOTE:**

**Loctite 592 to be used on all pipe threads.  
Lubricate all grease zerks.**

---

## Chapter 2 Contents

Rivet Nut Installation . . . . .	2-2
Footrest Assembly . . . . .	2-3

# Rivet Nut Installation

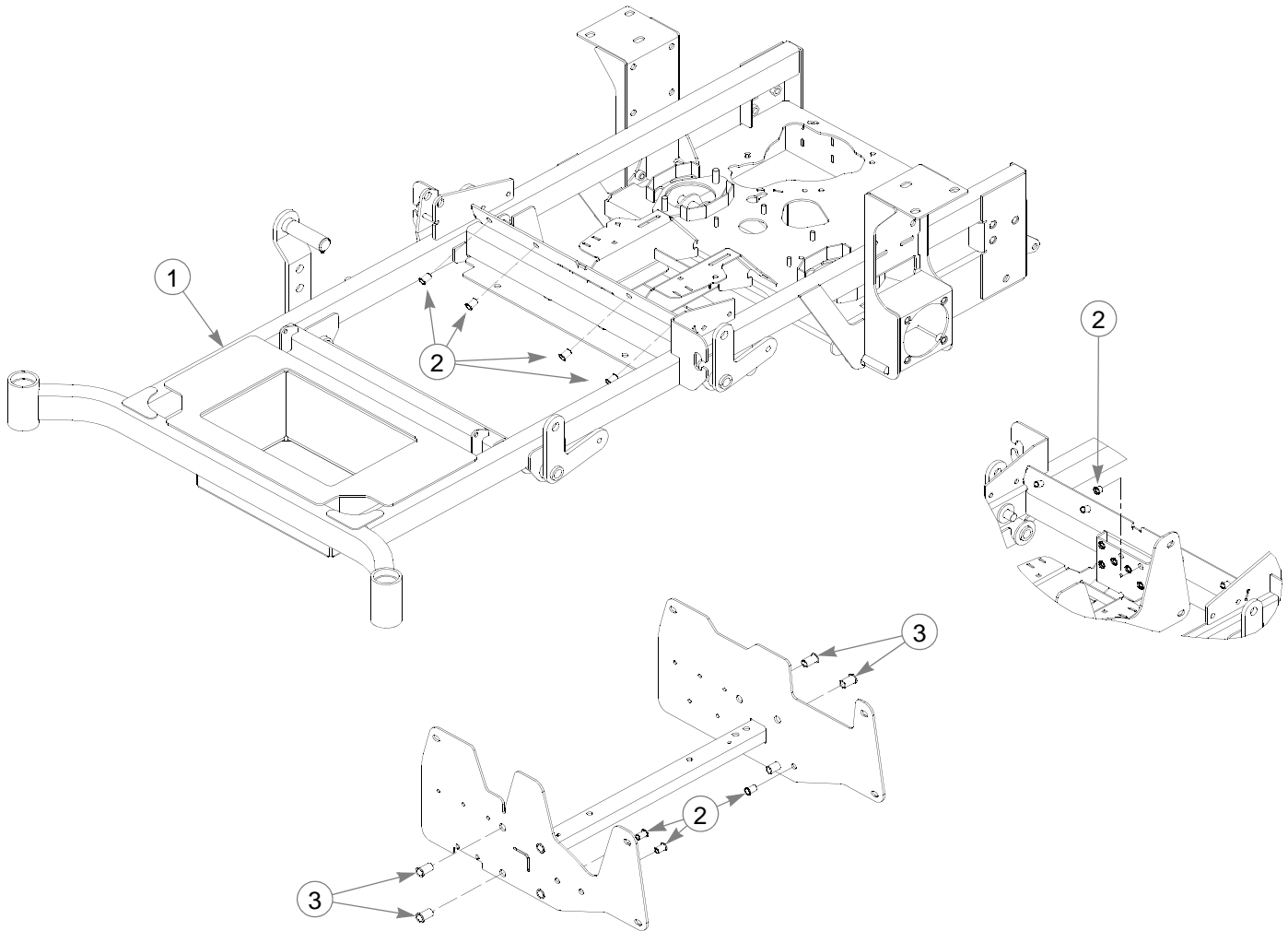

ITEM NO.	SERVICE PART NO.	MFG. PART NO.	QTY.	DESCRIPTION
1	546572	381848	1	ATZ FRAME
2	N/A	808493	13	RIVET NUT, 3/8-16 THREAD
3	N/A	600961	8	RIVET NUT, 1/2-13 THREAD

## NOTES:



# Footrest Assembly

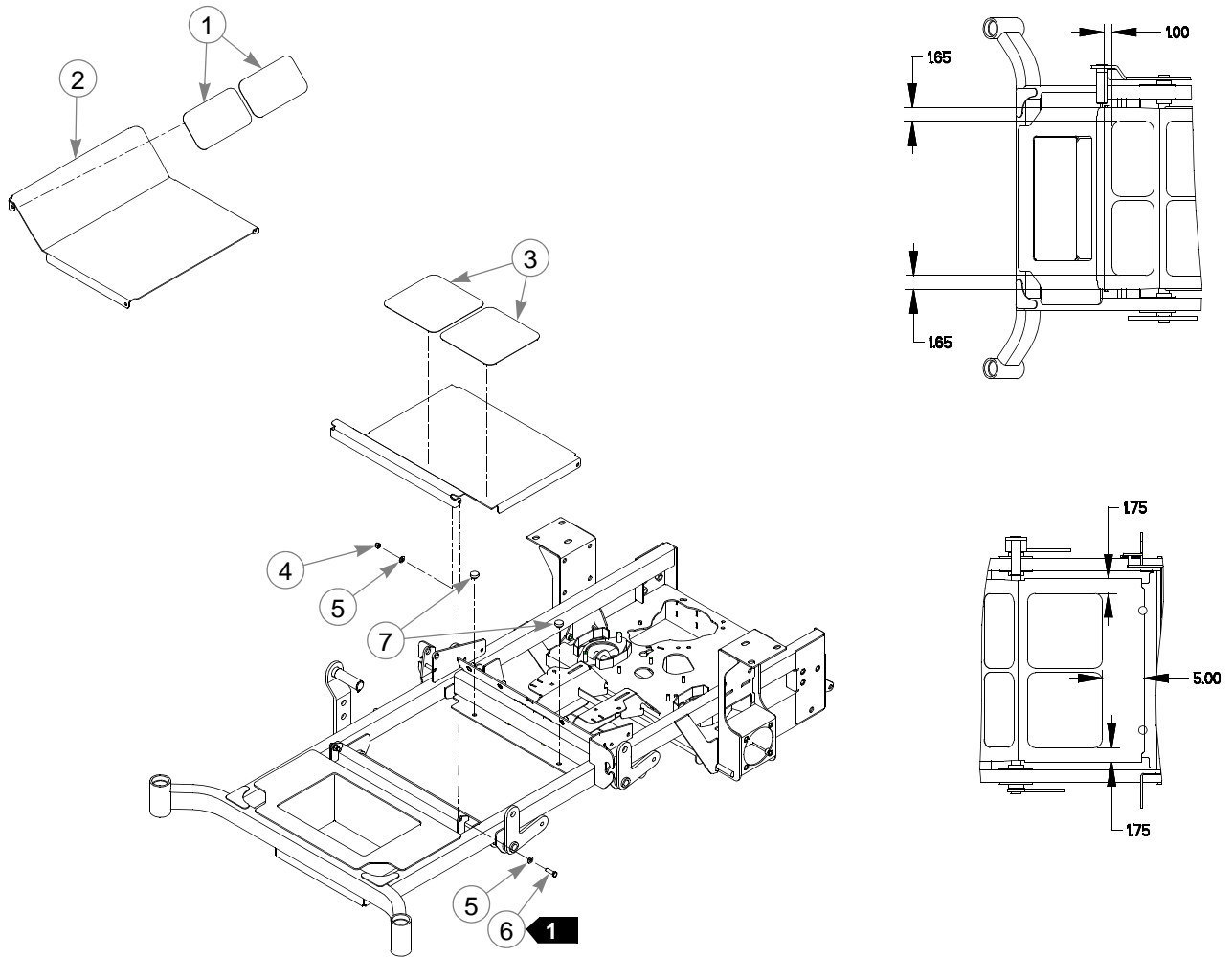

ITEM NO.	SERVICE PART NO.	MFG. PART NO.	QTY.	DESCRIPTION
1	359547	359547	2	STEP TREAD
2	395533	395533	1	FLOOR PLATE
3	305615	305615	2	STEP TREAD
4	086660	086660	2	NT .375-16 HX LK NY
5	767954	767954	4	FW .406 X .812 X .060 SAE HD ZN
6	052860	052860	2	CS .375-16 X 1.25 HX G5 ZNYC
7	781880	781880	2	RUBBER BUMPER

### NOTES:

1. Do not tighten, Floor must be able to pivot on these bolts.



---

## Chapter 3 Contents

Hydraulic System Installation—Kawasaki 31 HP HT Engine. . . . . 3-2



# **Hydraulic System Installation—Kawasaki 31HP HT Engine**

INDEX NO.	SERVICE PART NO.	MFG. PART NO.	QTY	DESCRIPTION
1	705608	705608	4	CS .250-20 X 2.25 HX G5 ZNYC
2	768515	768515	10	FW .281 X .625 X .051/.080 HD ZNYC
3	713198	713198	6	SEAL 3/8 X 3/4 X 7.25" LONG
4	033035	033035	2	WEATHERSTRIP .12 X .75 X 11.75" LONG
5	783704	783704	2	OIL COOLER
6	068551	068551	4	NT .250-20 HX NL ZNYC
7	032763	032763	1	BREATHER CAP
8	032771	032771	1	STRAINER
9	357616	357616	1	SUPER Z RESERVOIR
10	034272	034272	4	NT .312-18 HX G5 ZNYC
11	768523	768523	4	FW .343 X .687 X .051/.080 HD ZNYC
12	055947	055947	2	CS .250-20 X .50 HX G5 ZNYC
13	788042	788042	2	PUMP, HYDRO-GEAR BDP-21L-408
14	008193	008193	4	NT .500-13 HX G5 ZNYC
15	767962	767962	12	FW .531 X 1.063 X .090 SAE HD ZN
16	783928	783928	1	ZAF SERIES FILTER HEAD
17	783936	783936	1	FILTER ELEMENT
18	109604	109604	1	REMOTE AIR MOUNT BRACKET W/A
19	077859	077859	8	CS .500-13X3.250 HX G5
20	789339	789339	1	MOTOR, WHITE RC26 CCW
21	601260	601260	1	MOTOR, WHITE RC26 CW
22	700484	700484	2	HOSE CLAMP
23	601629	N/A	2	HOSE, COOLER-LT RES
24	601628	N/A	2	HOSE, LEFT PUMP-COOLER
25	601627	N/A	2	HOSE, COOLER-RT RES
26	601626	N/A	2	HOSE, RIGHT PUMP-COOLER
27	784082	N/A	2	FITTING, #8 BEADED TUBE-ORB 90°
28	781534	N/A	4	FITTING, STR-8MORB/-8MSL
29	781658	N/A	1	HEX PLUG FITTING, STR-8MORB
30	784025	N/A	1	SUCTION HOSE ASSY, FILTER-PUMP
31	783993	N/A	1	SUCTION HOSE ASSY, FILTER-PUMP
32	788174	N/A	1	FITTING, T -8MJIC/8MJIC
33	601687	N/A	1	FITTING, 10 FX05-S
34	601631	N/A	1	SUCTION HOSE, #12 16" LONG
35	601265	N/A	1	TUBE, LP-BM LT LOOP
36	601264	N/A	1	TUBE, RP-TM LT LOOP
37	601284	N/A	1	TUBE, RP-TM RT LOOP
38	601285	N/A	1	TUBE, LP-BM RT LOOP
39	781526	N/A	4	FITTING, 90-10MORB/-8MSL
40	784108	N/A	2	FITTING, #6 BEADED TUBE-ORB 45°
	N/A	601616	1	HYDRO KIT (INCLUDES ITEMS 23-40)

## **NOTES:**

1. Hydraulic system capacity is 5 US quarts of 20W50 motor oil. Fill reservoir to within 1" of top of Item 8 (032771 Strainer).

---

## HYDRAULIC SYSTEM CHARGING PROCEDURE

1. Set handles in the neutral position.
2. Start engine at idle.
3. Let run for a minimum of 30 seconds.
4. Stroke handles to forward position.
5. If motors do not turn in 15 seconds return handles to neutral and repeat step 3 and 4 (one time).
6. If motors do not turn after second attempt, shut off the engine and check for oil at the pump.
7. Increase throttle to half speed and work handles through forward and reverse position until the motor operates smoothly throughout the entire speed range.

**Note:**

Seal Kit for hydraulic pump; 784983 (BDP21L Overhaul Seal Kit)

---

## Chapter 4 Contents

Battery Installation . . . . .	4-2
Deck Lift Assembly . . . . .	4-4
Park Brake Assembly . . . . .	4-6
Steering Assembly . . . . .	4-8
Steering Sub-Assembly . . . . .	4-10
Pump Belt and Pulleys Installation . . . . .	4-12

# **Battery Installation**

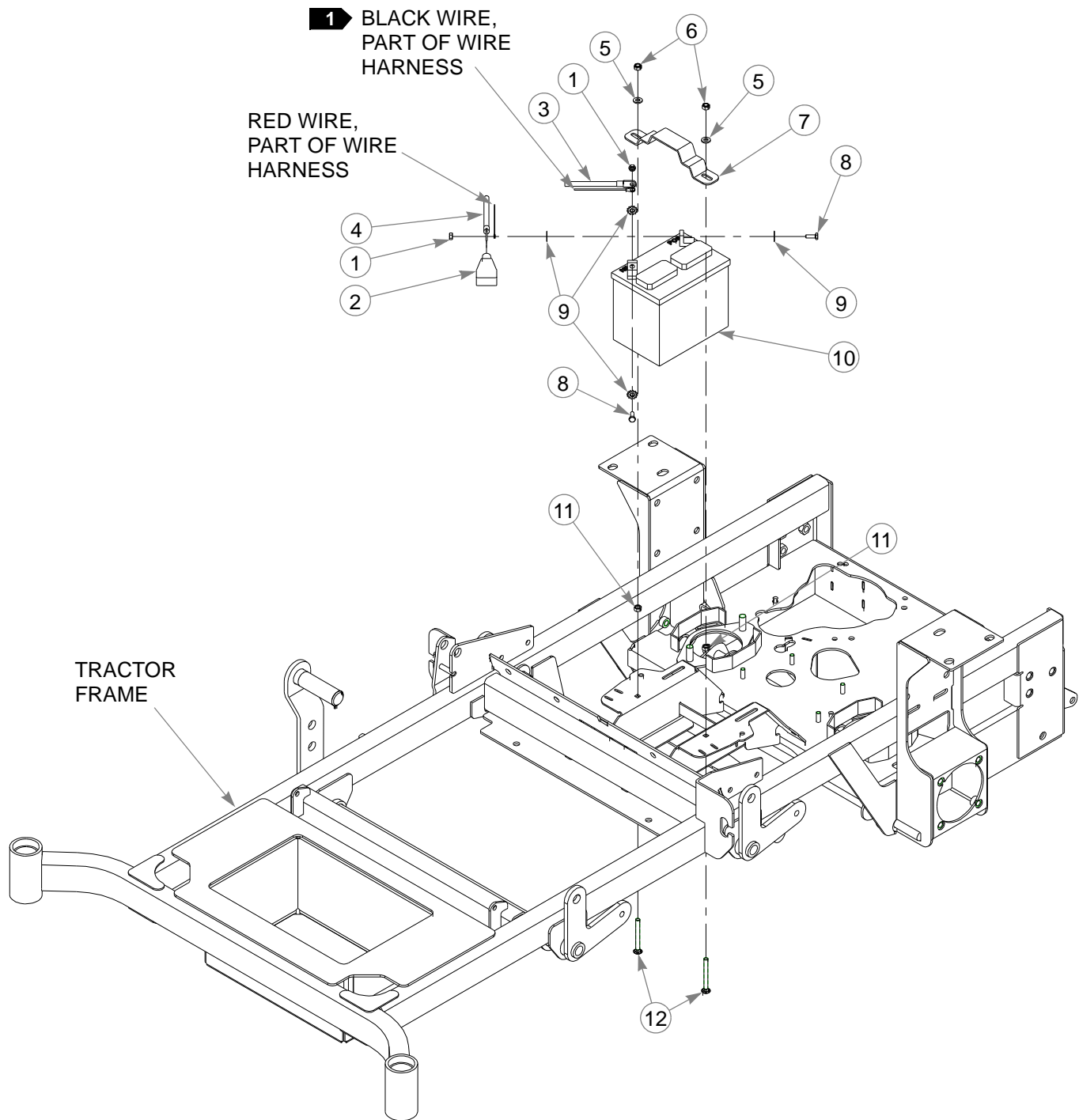



---

## **Battery Installation**

<b>ITEM NO.</b>	<b>SERVICE PART NO.</b>	<b>MFG. PART NO.</b>	<b>QTY</b>	<b>DESCRIPTION</b>
1	024927	024927	2	NT .250-20 HX GR 5 ZN
2	771428	771428	1	RED BATTERY CABLE BOOT
3	796219	796219	1	BATTERY GROUND CABLE
4	744276	744276	1	POSITIVE BATTERY CABLE
5	768523	768523	2	FW .343 X .687 X .051/.080 HD ZNYC
6	058776	058776	2	NT .312-18 HX NL ZN
7	348417	348417	1	BATTERY CLAMP STRAP
8	055939	055939	2	CS .250-20 X .750 HX G5 ZN
9	029868	029868	4	LW .250 INT-EXT TOOTH ZN
10	740696	740696	1	BATTERY
11	034272	034272	2	NT .312-18 HX G5 ZN
12	779850	779850	2	CB .312-18 X 3.00 FUL ZN

---

### **NOTES:**

1. When performing service on mower, disconnect battery ground cable and black wire of harness and do not reconnect to battery until engine is ready to be started. See Owners Manual.



---

## **Deck Lift Assembly**

ITEM NO.	SERVICE PART NO.	MFG. PART NO.	QTY	DESCRIPTION
1	348318	348318	1	STOP HANDLE
2	600437	600437	1	HEIGHT ADJUSTMENT STOP (1/2" DIA PIN)
3	783001	783001	1	DECK LIFT INDICATOR
4	704643	704643	8	NT .437-14 HX FLG ZN
5	781294	781294	7	CLIP E, 1.00 X.625X .050
6	782995	782995	2	DECK LIFT SPRING ASSEMBLY
7	015495	015495	4	STRAIGHT GREASE FITTING
8	055749	055749	3	CS .437-14X1.750 HX G5 ZNYC
9	348391	018846	4	DECK LIFT CHAIN
10	756270	756270	1	CS .312-18 X 1.50 FLTHR GR5 ZNYC
11	034272	034272	1	NT .312-18 HX G5 ZNYC
12	348458	348458	1	DECK LEVELER YOKE W/A
13	781229	781229	1	CE .750X2.25 X1.75 HEADLESS
14	781831	781831	1	CS .437-14 X 1.750 FULTH G5 ZNYC

---

### **NOTES:**

1. Apply grease to zerks (see owners manual).



---

## Park Brake Assembly

ITEM NO.	SERVICE PART NO.	MFG. PART NO.	QTY	DESCRIPTION
1	767954	767954	12	FW .406 X .812 X .060 SAE HD ZN
2	768523	768523	8	FW .34 3X .687 X .051/.080 HD ZN/YL
3	023655	023655	2	NT .312-24 HXZY NL
4	782979	782979	2	CS .375-16 X 4.75 HX G5 ZN
5	063198	063198	4	CS 10-24 X .750 HXFLK ZN
6	781211	781211	2	PUSH BUTTON SWITCH
7	059832	059832	4	NT #10-24 HX NL ZN
8	034272	034272	4	NT .312-18 HX G5 ZN
9	054502	054502	4	NT .375-16 HX GRD 5 ZN
10	354035	354035	2	WHITE BRAKE LEVER EXTENSION
11	005116	005116	4	CS .375-16 X 1.375 HX G5 ZN
12	350397	350397	2	BRAKE LINK TURNBUCKLE
13	350330	350330	1	L.S. BRAKE PIVOT ARM
	350264	350264	1	R.S. BRAKE PIVOT ARM
14	765339	765339	4	BUSHING
15	086660	086660	2	NT .375-16 HX LK NY
<b>3</b>	783126	783126	1	LH WHITE BRAKE ASSY
<b>4</b>	783118	783118	1	RH WHITE BRAKE ASSY
17	789321	789321	2	WHITE HUB ASSEMBLY
18	036236	036236	4	CS .312-18 X 1.000 HX G5 ZN
19	789644	N/A	2	NUT FOR WHITE MOTOR (RC28)
20	601344	N/A	2	KEY FOR WHITE MOTOR
21	712927	712927	8	FW .344 X 1.00 X .12 HRD ZNYC
22	048876	048876	8	CS .312-18 X .750 HX G8 ZNYC

---

### NOTES:

1. Torque to 280-310 ft.-lbs. Included with wheel motor.
2. Torque to 24 ft.-lbs.
3. 783126 used on left wheel.
4. 783118 used on right wheel.



---

# **Steering Assembly**

<b>ITEM NO.</b>	<b>SERVICE PART NO.</b>	<b>MFG. PART NO.</b>	<b>QTY</b>	<b>DESCRIPTION</b>
1	110679	110679	1	STEERING CONTROL PANEL
2	781716	781716	2	SS .500-13 X 1.75 SH ZN
3	053199	053199	2	NT .500-13 HX JAM ZN
4	055822	055822	8	CS .375-16 X .750 HX G5 ZN
5	767954	767954	8	FW .406 X .812 X .060 SAE HD ZN
6	768523	768523	16	FW .34 3X .687 X .051/.080 HD ZN/YL
7	023655	023655	4	NT .312-24 HXZY NL
8	781286	781286	2	PUMP ROD ADJUSTER ASSEMBLY
9	600221	600221	2	CENTERING DAMPENER
10	781922	781922	4	DAMPENER BALL STUD
11	029876	029876	2	LW .312 INT-EXT TOOTH Z
12	347684	347684	2	SUPER Z PUMP ARM
13	704163	704163	2	CS .250-20 X 2.00 HX G5 ZN
14	768515	768515	4	FW .281 X .625 X .051/.080 HD ZN/YL
15	068551	068551	2	NT .250-20 HX NL ZN
16	348797	348797	2	ADJUSTABLE PIVOT
17	036244	036244	6	CS .375-16 X 1.000 HX G5 ZN
18	034272	034272	4	NT .312-18 HX G5 ZN

---

## **NOTES:**

# Steering Sub-Assembly

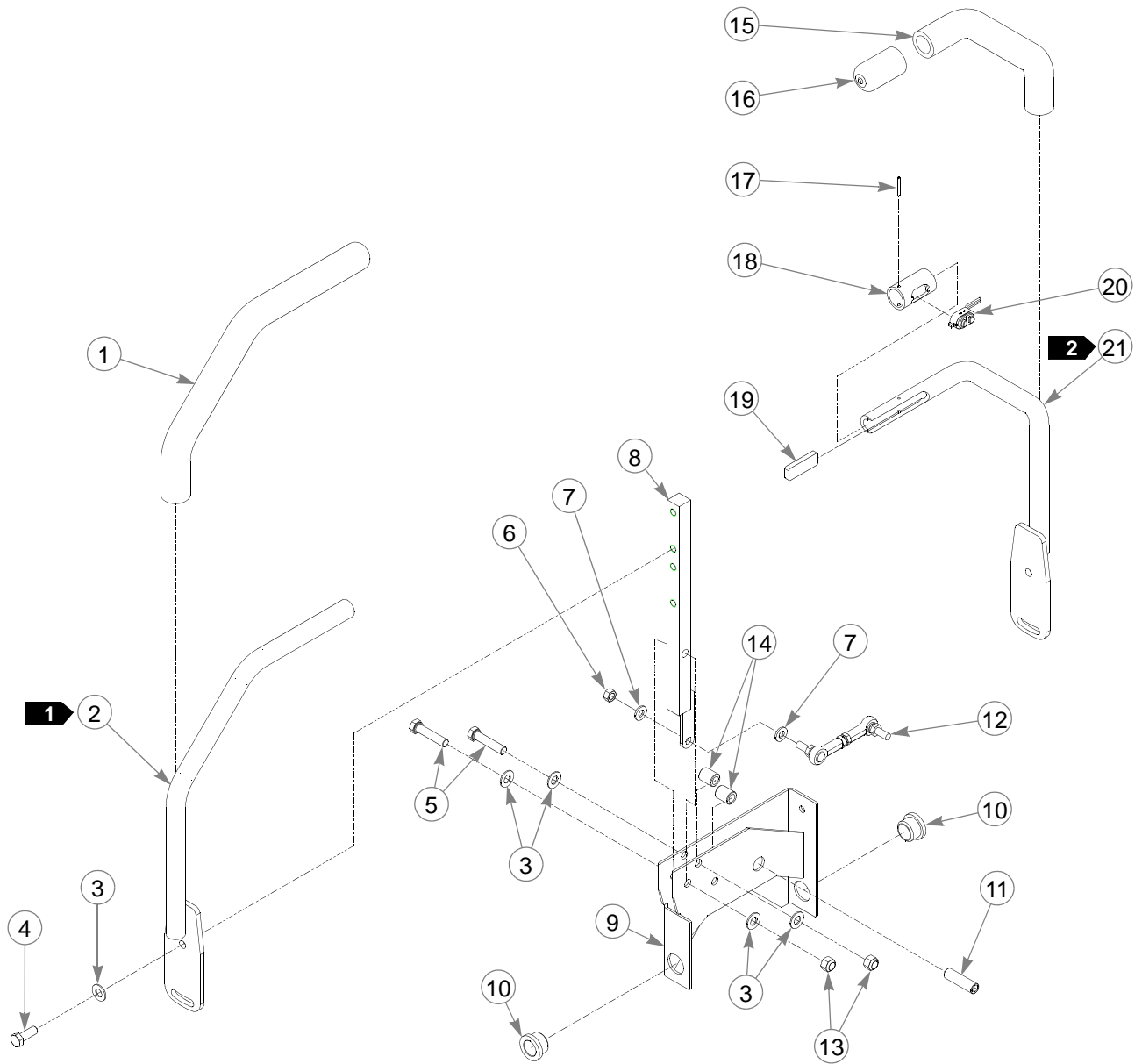



---

## **Steering Sub-Assembly**

ITEM NO.	SERVICE PART NO.	MFG. PART NO.	QTY.	DESCRIPTION
1	781260	N/A	1	STEERING BAR GRIP
2	348755	348755	1	STEERING BAR
3	767954	767954	16	FW .406 X .812 X .060 SAE HD ZN
4	036244	036244	4	CS .375-16 X 1.000 HX G5 ZN
5	705178	705178	6	CS .375-16 X 1.750 HX G5 ZN
6	023655	023655	2	NT .312-24 HXZY NL
7	768523	768523	4	FW .343X .687 X .051/.080 HD ZN/YL
8	348946	348946	2	STEERING ARM MOUNT
9	348888	348888	1	STEERLEVER SUPPORT LH (SHOWN)
	348714	348714	1	STEERLEVER SUPPORT RH
10	781153	781153	4	BUSHING
11	781716	781716	2	SS .500-13 X 1.75 SH ZN
12	781583	781583	2	BRAKE ROD ASSEMBLY
13	086660	086660	6	NT .375-16 HX LK NY
14	348862	348862	4	STEERLEVER BUSHING
15	601769	N/A	1	GRIP, RH HANDLE LOWER
16	601768	N/A	1	GRIP, RH HANDLE END
17	053660	053660	1	RP .125DX1.000 LG ZN
18	110674	110674	1	TILT SWITCH HOUSING
19	110681	110681	1	KEY, TILT SWITCH HANDLE
20	601727	601727	1	TILT SWITCH WIRE HARNESS
21	110680	110680	1	STEERING HANDLE W/A

---

### **NOTES:**

1. Includes Item 1 (781260 Steering Bar Grip).
2. Includes Item 15 (601769 Lower Handle Grip) and Item 16 (601768 End Handle Grip)

# Pump Belt and Pulleys Installation

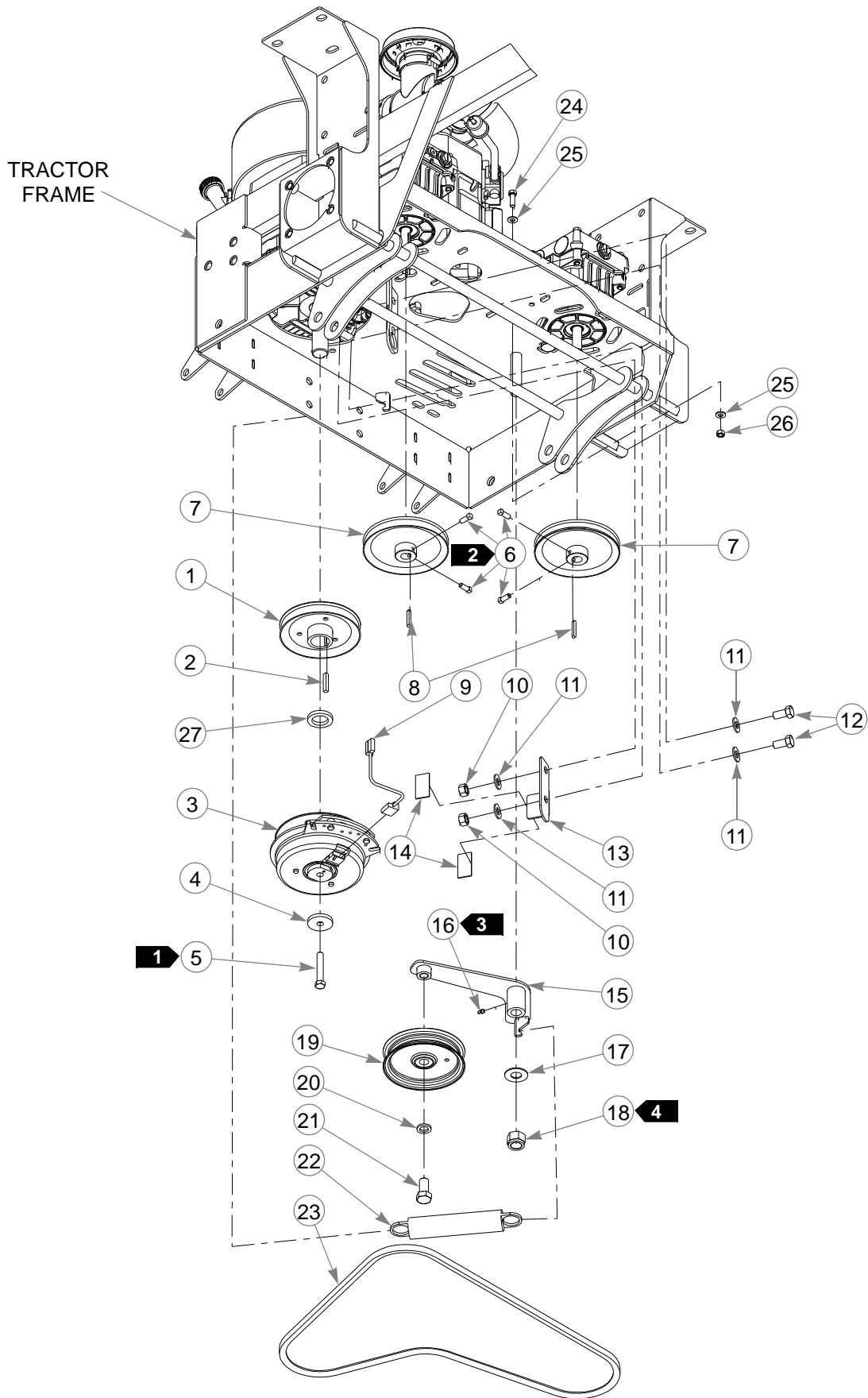

---

## **Pump Belt and Pulleys Installation**

ITEM NO.	SERVICE PART NO.	MFG. PART NO.	QTY	DESCRIPTION
1	601462	601462	1	ENGINE PULLEY
2	212076	212076	1	KEY 1/4 SQ X 1.50 LONG
3	601311	601311	1	WARNER CLUTCH
4	783829	783829	1	FW .460 X 1.750 X .250 ZNYC
5	785659	785659	1	CS .437-20 X 2.50 HX G5 ZNYC
6	083196	083196	4	SS .312-18X .750 SQ-HD ZN
7	601461	601461	2	PULLEY BDP-21
8	783712	783712	2	KEY FOR BDP21L
9	791251	791251	1	CLUTCH PIGTAIL HARNESS WITH DIODE
10	008193	008193	2	NT .500-13 HX G5 ZNYC
11	767962	767962	4	FW .531 X 1.063 X .090 SAE HD ZN
12	016527	016527	2	CS .500-13 X 1.00 HX G5 ZNYC
13	366765	366765	1	CLUTCH ANCHOR ANGLE
14	784918	784918	2	RUBBER BUMPER
15	349761	349761	1	PUMP IDLER ARM
16	015495	015495	1	STRAIGHT GREASE FITTING
17	025296	025296	1	FW .760 X 1.625 X .08 ZN
18	061101	061101	1	NT .750-10 HX NL ZN
19	781856	781856	1	IDLER PULLEY
20	028118	028118	1	FW .62 X 1.00 X.134 ZN
21	781872	781872	1	CS .625-11 X 1.50 HX G5 ZN
22	601016	601016	1	IDLER SPRING
23	601463	601463	1	A-SEC PUMP IDLER BELT
24	036236	036236	1	CS .312-18 X 1.00 HX G5 ZNYC
25	768523	768523	2	FW .343 X .687 X .051/.080 HD ZNYC
26	034272	034272	1	NT .312-18 HX G5 ZNYC
27	797654	797654	1	FW 1.156X1.750X.250 ZY

---

### NOTES:

1. Torque to 45-48 ft-lbs.
2. Torque to 12-15 ft-lbs.
3. Apply grease at zerk (see owners manual).
4. Do not torque Item 18 (NT .750-10 HX NL ZN), Item 15 (349761 Pump Idler Arm) should pivot freely.
5. **Electric clutch burnishing procedure:** After installing a new clutch it is important to burnish the clutch to insure maximum deck clutch life. In an open area with no bystanders set the engine speed to half throttle. Cycle the deck clutch on for 15 seconds, and then off for 15 seconds. Repeat this operation 10 times, it will require about 5 minutes to complete.



---

## Chapter 5 Contents

Kawasaki 31 HP Engine Installation . . . . .	5-2
Fuel System Installation. . . . .	5-6
Instrument Panel Assembly/Installation. . . . .	5-8
Electrical Schematic - Kawasaki (601555) . . . . .	5-10

# Kawasaki 31 HP Engine Installation

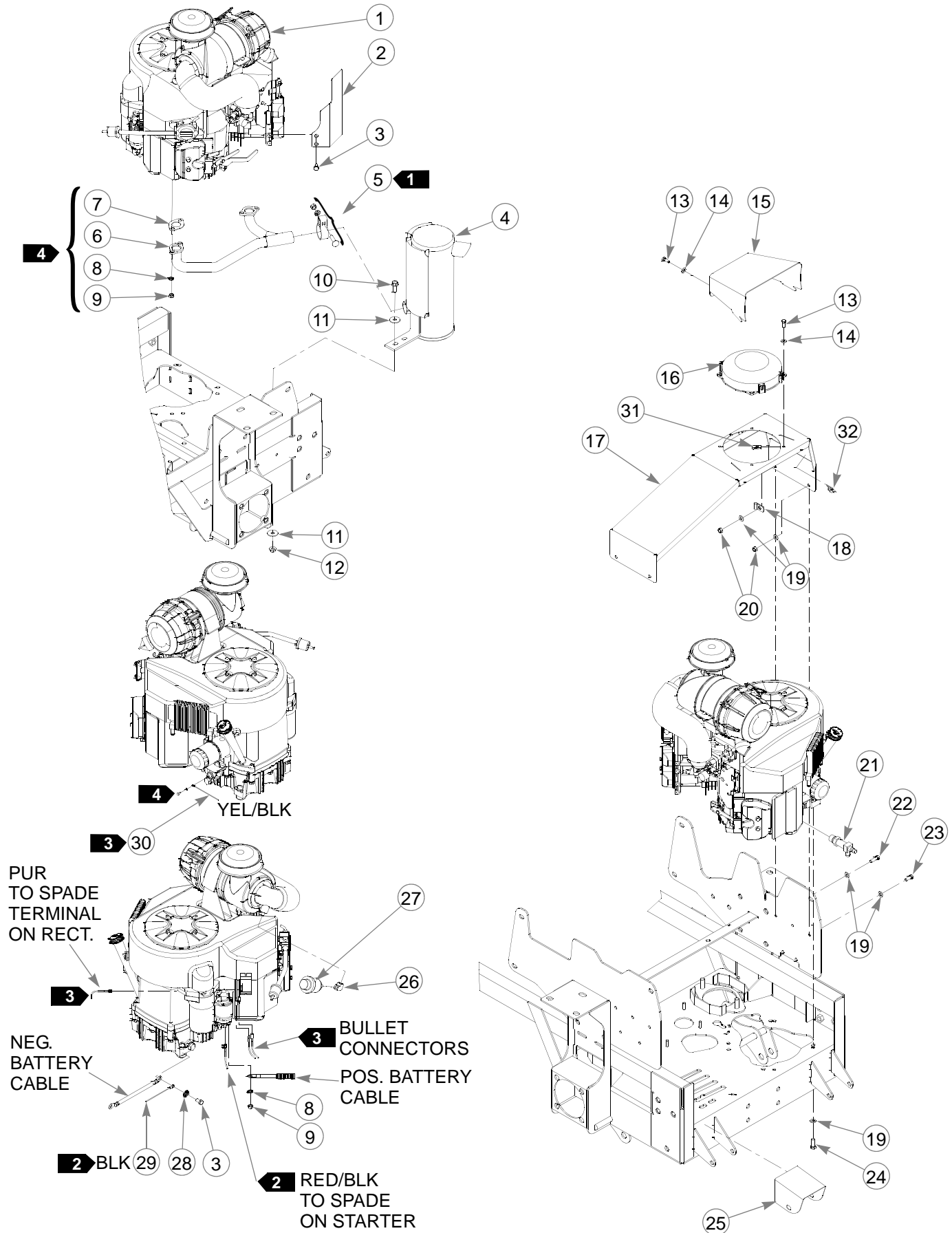

---

# **Kawasaki 31 HP Engine Installation**

ITEM NO.	SERVICE PART NO.	MFG. PART NO.	QTY	DESCRIPTION
1	601549	N/A	1	KAWASAKI 31 HP ENGINE
2	109743	109743	1	CABLES HEAT SHIELD
3	720516	720516	3	CS M8 X1.25 X 16 G10.9 HX
4	788018	788018	1	MUFFLER
5	785378	785378	1	1.50" MUFFLER CLAMP
6	601550	601550	1	MANIFOLD, 29/31 KAW
7	780841	780841	2	KAW MUFFLER GASKET
8	017004	017004	5	LW .312 MED SPRING ZN
9	782664	782664	5	NT M8-1.25 HX STAINLESS STEEL
10	029751	029751	2	CS .375-16 X 1.00 HXFLK ZNYC
11	705137	705137	4	FW .391 X 1.250 X .060 ZNYC
12	016899	016899	2	NT .375-16 HX FLK ZNYC
13	055939	055939	6	CS .250-20 X .75 HX G5 ZNYC
14	768515	768515	6	FW .281 X .625 X .051/.080 HD ZN/YL
15	109748	109748	1	HOOD SCOOP
16	783837	783837	1	ELECTRIC COOLER FAN
17	109604	109604	1	REMOTE AIR BRACKET
18	778738	778738	1	.312 WIRING CLAMP
19	768523	768523	12	FW .343 X .687 X .051/.080 HD ZN/YL
20	034272	034272	4	NT .312-18 HX G5 ZN
21	796524	796524	1	M20X2.5 OIL DRAIN VALVE
22	036236	036236	1	CS .312-18 X 1.00 HX G5 ZNYC
23	034280	034280	3	CS .312-18 X .750 HX G5 ZNYC
24	036244	036244	4	CS .375-16 X 1.00 HX G5 ZNYC
25	377994	377994	1	HEAT SHIELD, MMZ ROLLER
26	601257	601257	1	FITTING, 90 1/8NPT BRASS
27	788943	788943	1	AIR FILTER INDICATOR
28	029876	029876	1	LW .312 INT-EXT TOOTH ZN
29	601555	601555	1	XR7 COMMON WIRE HARNESS
30	601561	601561	1	WIRING HARNESS, KAWASAKI 31
31	044818	044818	4	CN ZN TIN-C7343-1420
32	047654	047654	1	CLIP

---

## **NOTES:**

1. Includes mounting hardware.
2. Wires from Item 29 (ATZ 2008 Wire Harness 601555).
3. Wires from Kawasaki 31HP Wiring Harness (601561).
4. Supplied with engine.
5. Engine oil capacity, Refer to engine owner's manual.
6. Air filter service parts:

601652	MAIN AIR FILTER ELEMENT
601653	SAFETY AIR FILTER ELEMENT





---

# **Fuel System Installation**

ITEM NO.	SERVICE PART NO.	MFG. PART NO.	QTY	DESCRIPTION
1	779306	779306	2	3.5" FUEL CAP
2	793240	793240	1	LEFT SIDE Z FUEL TANK
3	793232	793232	1	RIGHT SIDE Z FUEL TANK
4	106732	106732	1	REAR SEAT SUPPORT
5	712919	712919	12	FW .406 X 1.00 X .12 HRD ZN
6	767954	767954	3	FW .406 X .812 X .060 SAE HD ZN
7	055822	055822	12	CS .375-16 X .750 HX G5 ZN
8	000398	000398	1	CLAMP
9	036244	036244	4	CS .375-16 X 1.000 HX G5 ZN
10	045088	045088	1	HOSE CLAMP 1"
11	347989	347989	1	FUEL SHUT-OFF BRACKET
12	015818	015818	1	FUEL LINE 50" TOTAL
13	015818	015818	1	FUEL LINE 39" TOTAL
14	015818	015818	1	FUEL LINE 7" TOTAL
15	000323	000323	6	CLIP
16	705954	705954	8	CS .500-13 X 1.00 HX G5 ZN
17	767962	767962	8	FW .531 X 1.063 X .090 SAE HD ZN
18	797084	797084	1	3-WAY FUEL VALVE
	000331	000331	3	BLACK CABLE TIE (NOT SHOWN)

---

## **NOTES:**

1. Torque to 20 ft.-lbs.
2. Supplied with Item 18 (3-way fuel switch.)
3. Included with new fuel tank.
4. Fuel tank service parts not shown:

PART NO.	DESCRIPTION
794107	1/4 ID, 3/8 OD, 1/16 WALL TUBING (25" LONG)
794081	FUEL FILTER SCREEN
785295	FLANGE GROMMET
792986	SITE-LINE FUEL FITTING



---

## **Instrument Panel Assembly/Installation**

<b>ITEM NO.</b>	<b>SERVICE PART NO.</b>	<b>MFG. PART NO.</b>	<b>QTY</b>	<b>DESCRIPTION</b>
1	776476	776476	1	PTO SWITCH
2	785808	785808	1	KEY SET
3	045898	045898	1	KEY SWITCH
4	000430	000430	2	SMALL/LONG WIRE TIE
5	785030	785030	1	CHOKE CABLE
6	712257	712257	1	RED INDICATOR LIGHT
7	714998	714998	2	MS #10-24 X .625 HX ZN
8	704932	704932	6	FW .219 X .500 X .048 ZN
9	769166	769166	1	HOUR METER
10	059832	059832	4	NT #10-24 HX NL ZN
11	601675	601675	1	THROTTLE CABLE
12	055947	055947	3	CS .250-20 X .500 HX G5 ZN
13	768515	768515	3	FW .281 X .625 X .051 /.080 HD ZN/YL
14	110151	110151	1	INSTRUMENT PANEL
15	601089	601089	2	RIVET .188 DIA BLK HD
16	060731	060731	2	CS 10-24X .500 HXFLK ZN
17	110152	110152	1	RELAY MODULE BRACKET
18	601554	601554	1	Z SPARK IGNITION CONTROLLER

---

### **NOTES:**

1. Part of 601555 (Wire Harness)

# Electrical Schematic - Kawasaki (601555)

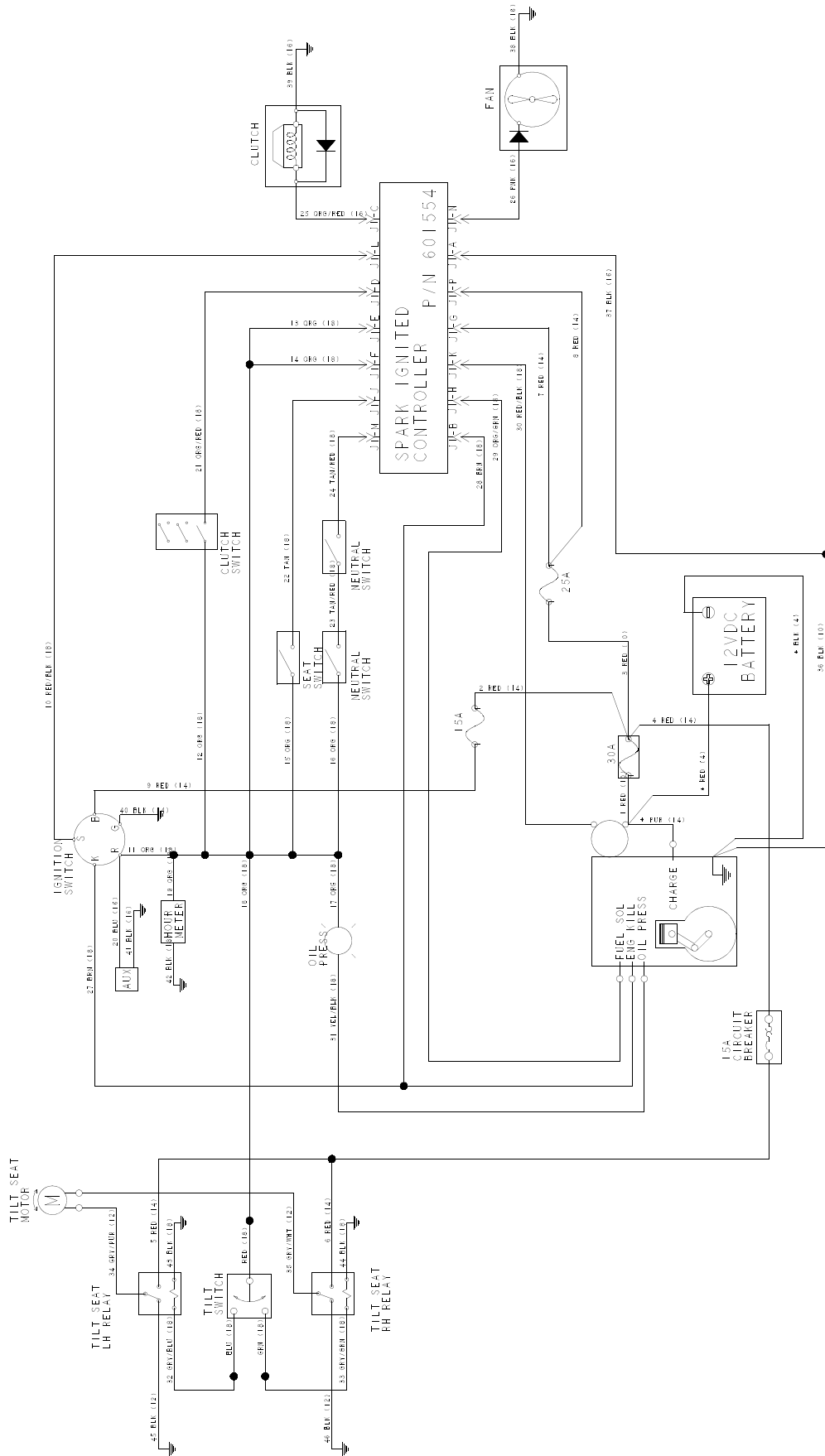

---

## Chapter 6 Contents

Front Wheel Assembly . . . . .	6-2
Semi-Pneumatic Tire/Wheel—789537 . . . . .	6-4
Drive Wheel Assembly Installation . . . . .	6-5
Anti-Rollover Wheel Assembly . . . . .	6-6

# Front Wheel Assembly

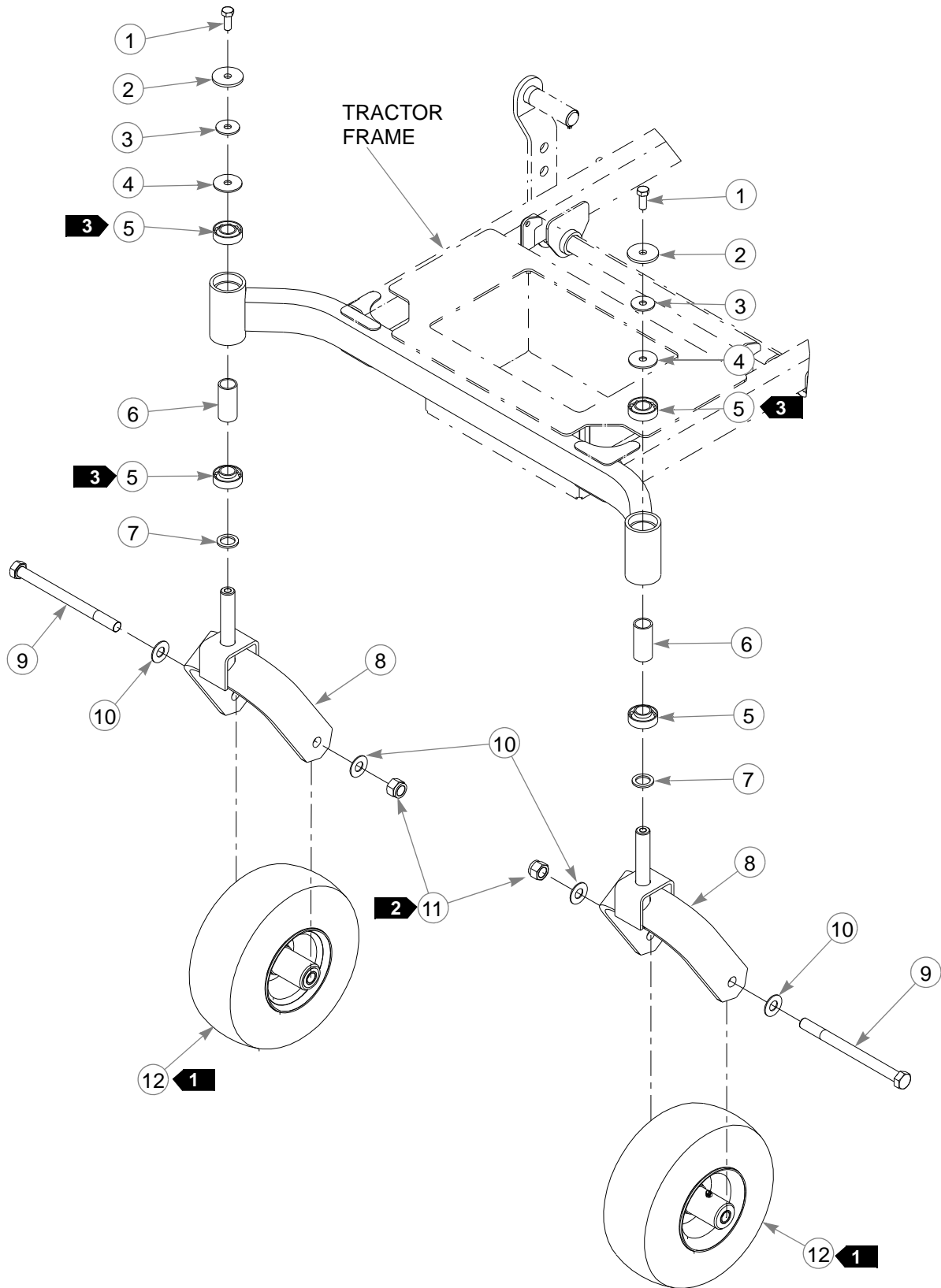

---

## **Front Wheel Assembly**

<b>ITEM NO.</b>	<b>SERVICE PART NO.</b>	<b>MFG. PART NO.</b>	<b>QTY</b>	<b>DESCRIPTION</b>
1	705954	705954	2	CS .500-13 X 1.25 HX G5 ZN
2	344267	344267	2	FW .510 X 2.15 X .187 SPL ZN
3	798603	798603	2	FW .515X1.65X.125 HD ZY
4	263517	263517	2	BEARING DISC
5	784223	784223	4	BEARING W/O COLLAR
6	387035	387035	2	SPACER, 1.07 X 1.312 X 2.793
7	045765	045765	2	FW 1.030 X 1.500 X.134 ZN
8	349266	349266	2	FORK
9	041475	041475	2	CS .750-10 X 9.50 HX ZN
10	025296	025296	4	FW .760 X 1.625 X .08 ZN
11	061101	061101	2	NT .750-10 HX NL ZN
12	789537	789537	2	WHEEL & TIRE ASSY

---

### **NOTES:**

1. Apply grease to zerks (see owners manual).
2. Torque to 100 ft.-lbs.
3. Assemble with extended inner race toward item 6 (387035 Spacer, 1.07 x 1.312 x 2.793).

# Semi-Pneumatic Tire/Wheel—789537

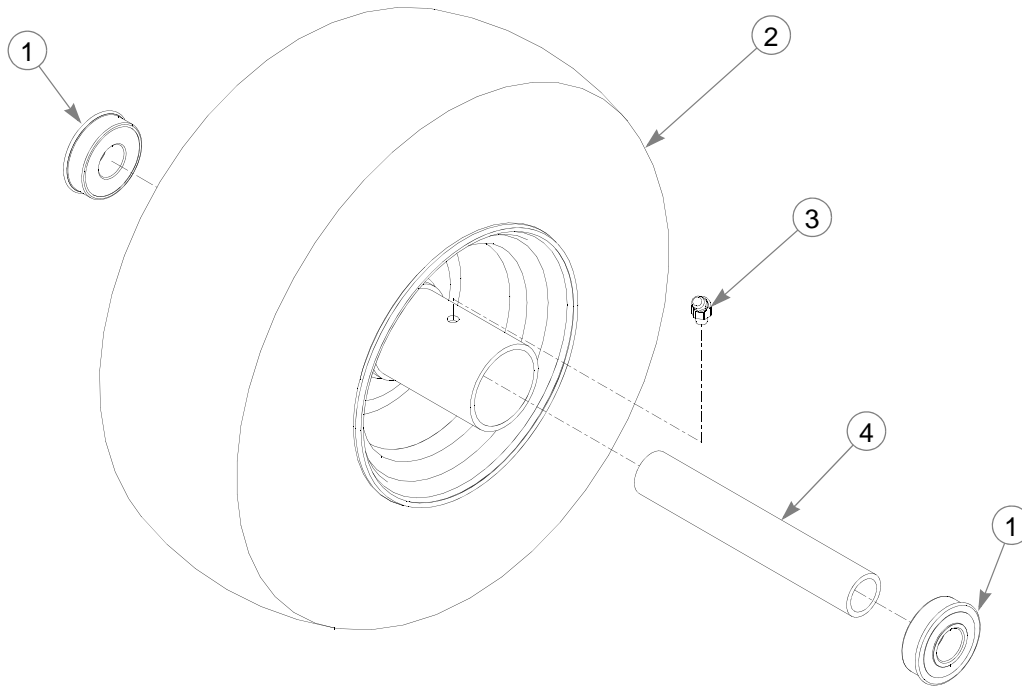

ITEM NO.	SERVICE PART NO.	MFG. PART NO.	QTY	DESCRIPTION
1	039677	N/A	2	WHEEL BEARING
2	789537	N/A	1	TIRE/WHEEL ASSEMBLY
3	015511	N/A	1	GREASE FITTING 45 DEG 1/4
4	782771	N/A	1	BEARING SPACER

## NOTES:



# Drive Wheel Assembly Installation

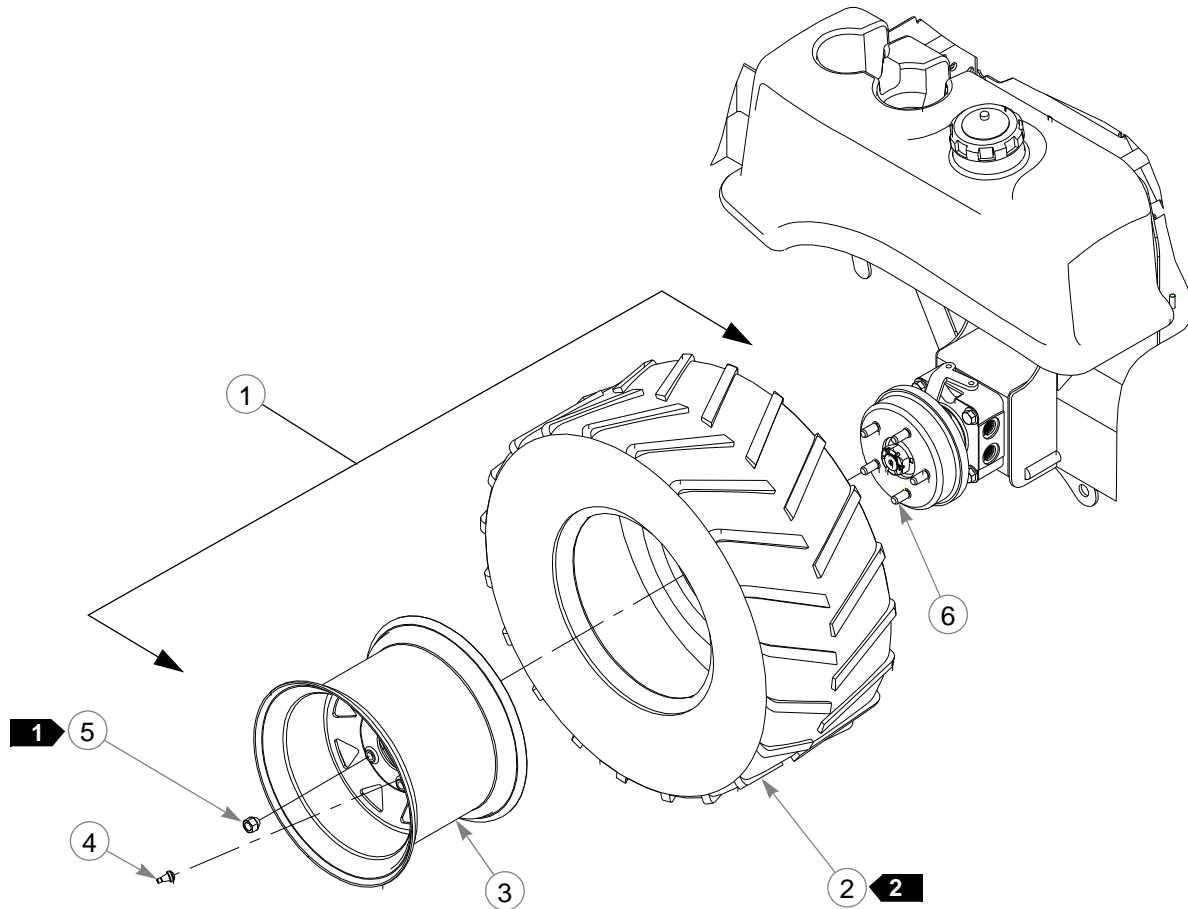

ITEM NO.	SERVICE PART NO.	MFG. PART NO.	QTY	DESCRIPTION
1	789529	789529	1	LH TIRE/WHEEL ASSEMBLY
	789420	789420	1	RH TIRE/WHEEL ASSEMBLY
2	783563	N/A		TIRE 24 X 12-12 AT101
3	784066	N/A		WHEEL ASSY 12 X 8.50 (ATZ)
4	019521	N/A		TIRE VALVE
5	061077	061077	5	WHEEL NUT (QTY PER WHEEL)
6	601085	N/A	10	½" WHEEL LUG STUD

## NOTES:

1. Torque to 65-75 ft. lbs.
2. Inflate tire to 8-12 psi.

# Anti-Rollover Wheel Assembly

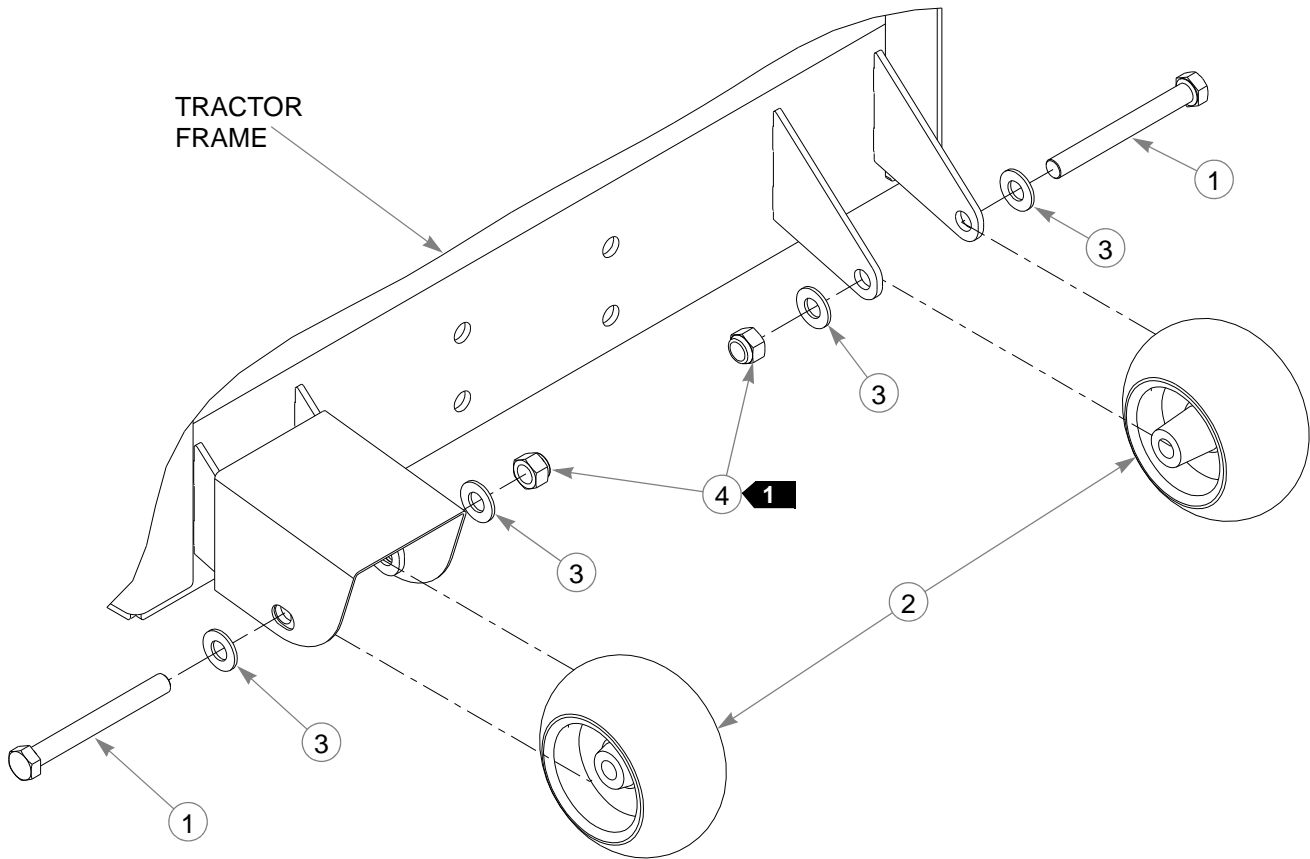

ITEM NO.	SERVICE PART NO.	MFG. PART NO.	QTY	DESCRIPTION
1	068239	068239	2	CS .500-13 X 4.500 HX G5 ZN
2	031997	031997	2	ANTI-SCALP WHEEL
3	767962	767962	4	FW .531 X 1.063 X .090 SAE HD ZN
4	781567	781567	2	NT .50-13 HX LK NY

## NOTES:

1. Do not torque, wheel must turn freely.

---

## Chapter 7 Contents

Weight Installation .....	7-2
ROPS Installation .....	7-4

# Weight Installation

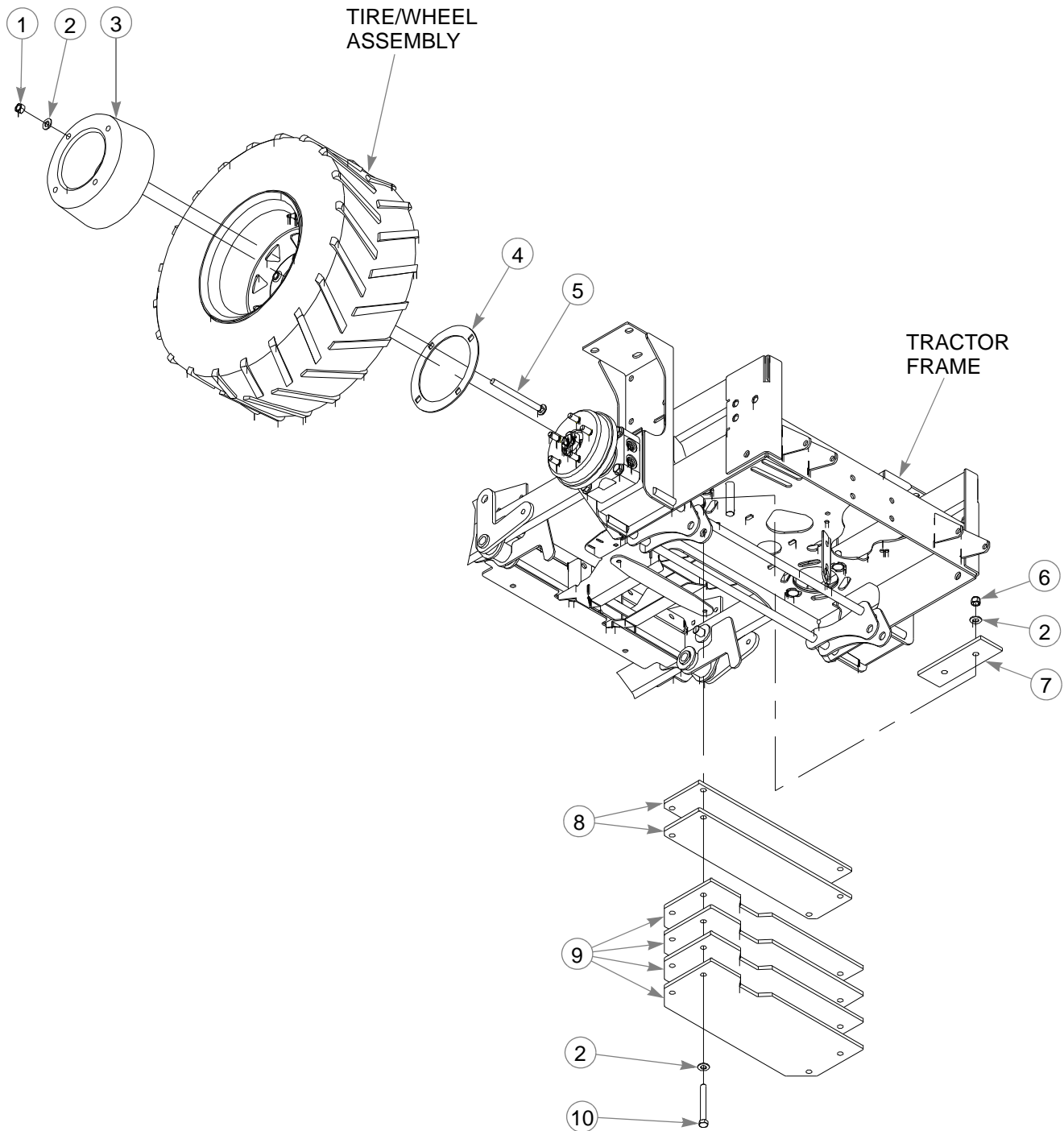

---

## **Weight Installation**

<b>ITEM NO.</b>	<b>SERVICE PART NO.</b>	<b>MFG. PART NO.</b>	<b>QTY.</b>	<b>DESCRIPTION</b>
1	008193	008193	8	NT .500-13 HX G5 ZNYC
2	767962	767962	16	FW .531 X 1.063 X .090 SAE HD ZN
3	789214	789214	2	MMZ WHEEL WEIGHT
4	392597	392597	2	WHEEL WEIGHT BACKING PLATE
5	792077	792077	8	CB .50-13 X 6 STD ZN
6	781567	781567	4	NT .50-13 HX LK NY
7	392035	392035	2	ATZ TOP WEIGHT PLATE
8	392191	392191	2	ATZ MIDDLE WEIGHT PLATE
9	392357	392357	4	ATZ BOTTOM WEIGHT PLATE
10	089938	089938	4	CS .500-13 X 4.00 HX G5 ZNYC

---

### **NOTES:**

# ROPS Installation

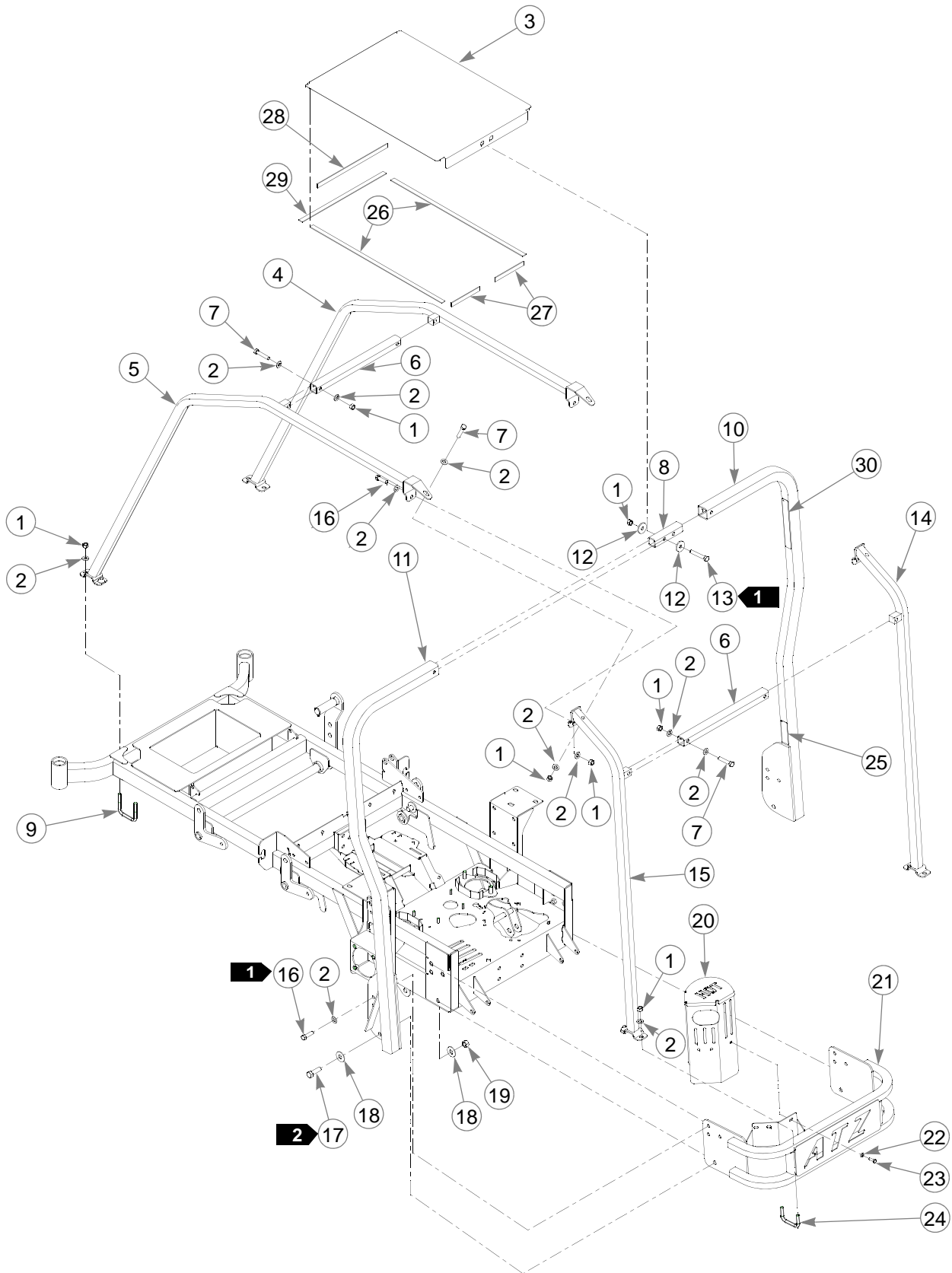

---

# **ROPS Installation**

ITEM NO.	SERVICE PART NO.	MFG. PART NO.	QTY.	DESCRIPTION
1	008193	008193	18	NT .500-13 HX G5 ZNYC
2	767962	767962	26	FW .531 X 1.063 X .090 SAE HD ZN
3	391375	391375	1	ATZ ROOF
4	381657	381657	1	ATZ FRONT R.S. ROPS
5	381665	381665	1	ATZ FRONT L.S. ROPS
6	381673	381673	2	ATZ ROPS CROSS SECTION
7	008573	008573	6	CS .500-13 X 2.50 HX G5 ZNYC
8	392985	392985	1	ROPS CONNECTOR
9	789412	789412	2	UB .50-13 X 3.25 X 3.0
10	392613	392613	1	R.H. ROPS
11	392605	392605	1	L.H. ROPS
12	078386	078386	4	FW .510 X 1.75 X .18 ZNYC
13	077859	077859	2	CS .500-13 X 3.25 HX G5
14	381723	381723	1	ATZ REAR R.S. ROPS
15	381731	381731	1	ATZ REAR L.S. ROPS
16	017616	017616	8	CS .500-13 X 1.75 HX G5 ZNYC
17	016642	016642	2	CS .625-11 X 2.00 HX G5 ZNYC
18	768002	768002	4	FW .687 X 1.750 X .105/.160 HD ZNYC
19	016972	016972	2	NT .625-11 HX G5 ZNYC
20	110855	110855	1	MUFFLER GUARD
21	381749	381749	1	ATZ ENGINE GUARD
22	768523	768523	3	FW .343 X .687 X .051/.080 HD ZNYC
23	036236	036236	3	CS .312-18 X 1.00 HX G5 ZNYC
24	789404	789404	2	UB .50-13 X 2.0 X 3.0
25	789396	N/A	1	TURF SERIAL NO PLATE
26	033035	033035	2	WEATHERSTRIP .12X.75 X 29
27	033035	033035	2	WEATHERSTRIP .12X.75 X 6.25
28	033035	033035	1	WEATHERSTRIP .12X.75 X 18.5
29	033035	033035	1	WEATHERSTRIP .12X.75 X 15.5
30	601979	601979	1	ATZ ROPS DECAL

---

## **NOTES:**

1. Torque to 73 ft.-lbs. (8 places).
2. Torque to 145 ft.-lbs. (2 places).





---

## Chapter 8 Contents

72" Side Discharge Deck Assembly (XR7) . . . . .	8-2
72" Side Discharge Deck Pulley Assembly (XR7) . . . . .	8-4
60" Side Discharge Deck Assembly . . . . .	8-6
60" Side Discharge Deck Pulley Assembly (XR7) . . . . .	8-8
Side Discharge Deck—"A" Adaptors . . . . .	8-10
60" Rear Discharge Deck Assembly . . . . .	8-12
60" Rear Discharge Deck Pulley Assembly . . . . .	8-14
Spindle Assembly—796235 . . . . .	8-16
Spindle Assembly—796680 . . . . .	8-17

# 72" Side Discharge Deck Assembly (XR7)

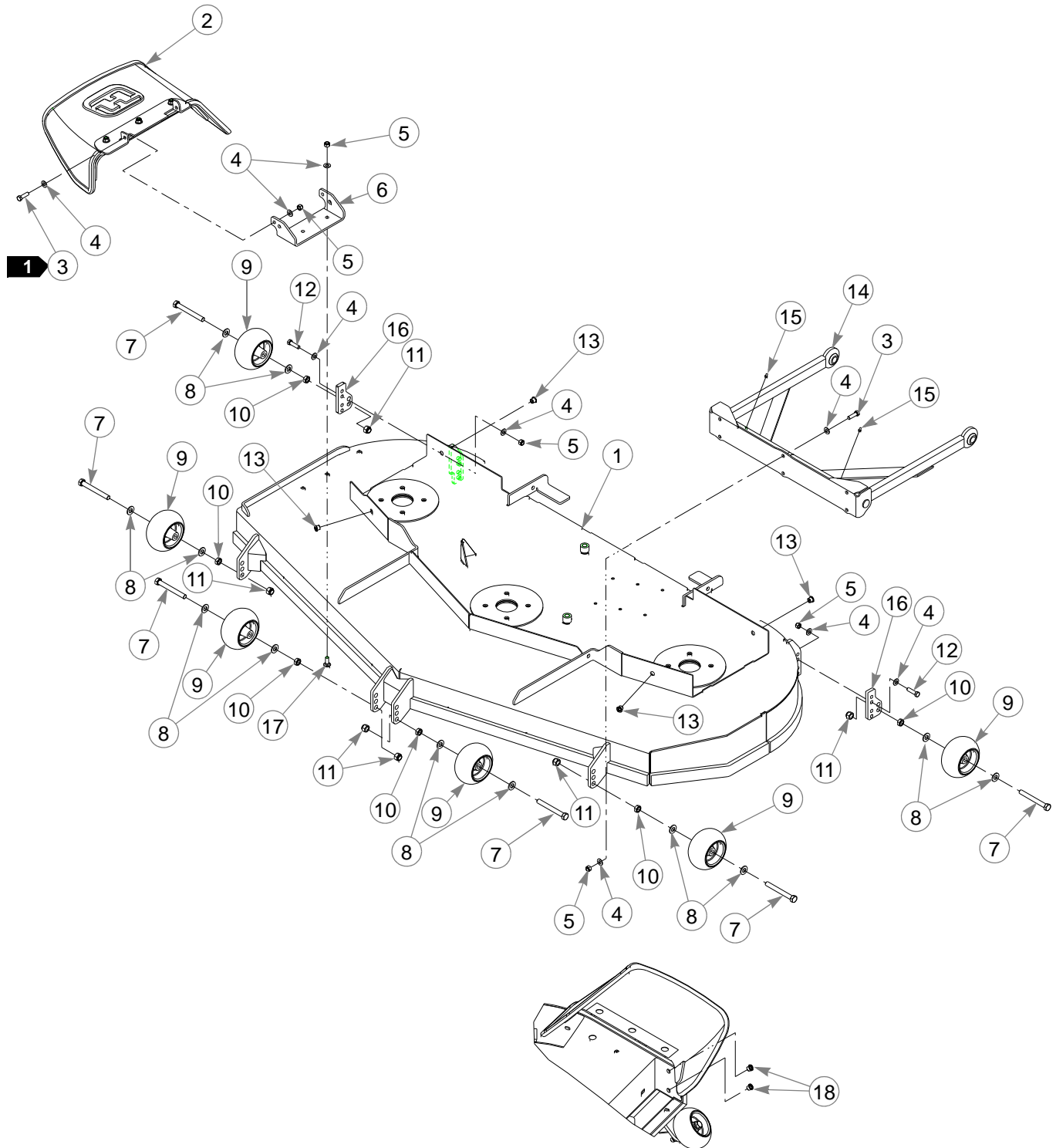

---

## **72" Side Discharge Deck Assembly**

ITEM NO.	SERVICE PART NO.	MFG. PART NO.	QTY	DESCRIPTION
<b>3</b> 1	548453	108649	1	72" DECK WACRATED
2	798694	798694	1	RUBBER CHUTE ASSEMBLY
3	052860	052860	8	CS .375-19 X 1.250 HX G5 ZN
4	767954	767954	26	FW .406 X .812 .060 SAE HD ZN
5	086660	086660	14	NT .375-16 HXZY NL
6	103010	103010	1	DISCHARGE CHUTE MOUNT BRACKET
7	781708	N/A	6	CS .500-13 X 4.25 HX G5 ZN
8	767962	N/A	12	FW .531 X 1.063 X .090 SAE HD ZN
9	031997	N/A	6	ANTI-SCALP WHEEL
10	053199	N/A	6	NT .500-13 HX JAM ZN
11	781567	781567	6	NT .50-13 HX LK NY
12	005116	005116	4	CS .375-16X1.375 HX G5
13	808485	808485	4	5/16-18 THREAD RIVET NUT
14	314104	314104	1	PUSHER
15	015495	015495	2	STRAIGHT GREASE FITTING
16	103184	103184	2	REAR ANTI-SCALP BRACKET
17	025395	025395	2	CB .375-16 X 1.00 STD CD
18	808493	808493	2	3/8-16 THREAD RIVET NUT
<b>2</b>	788166	788166	6	ANTI SCALP WHEEL ASSY

---

### **NOTES:**

1. Do not torque, Item 2 (798694 Discharge Chute) must pivot freely.
2. Includes items 7, 8, 9, and 10.
3. Service part deck includes decals (see "72" & 60" Side Discharge Deck Decals(XR7)" on page 10-4 for listing of decals).

# 72" Side Discharge Deck Pulley Assembly (XR7)

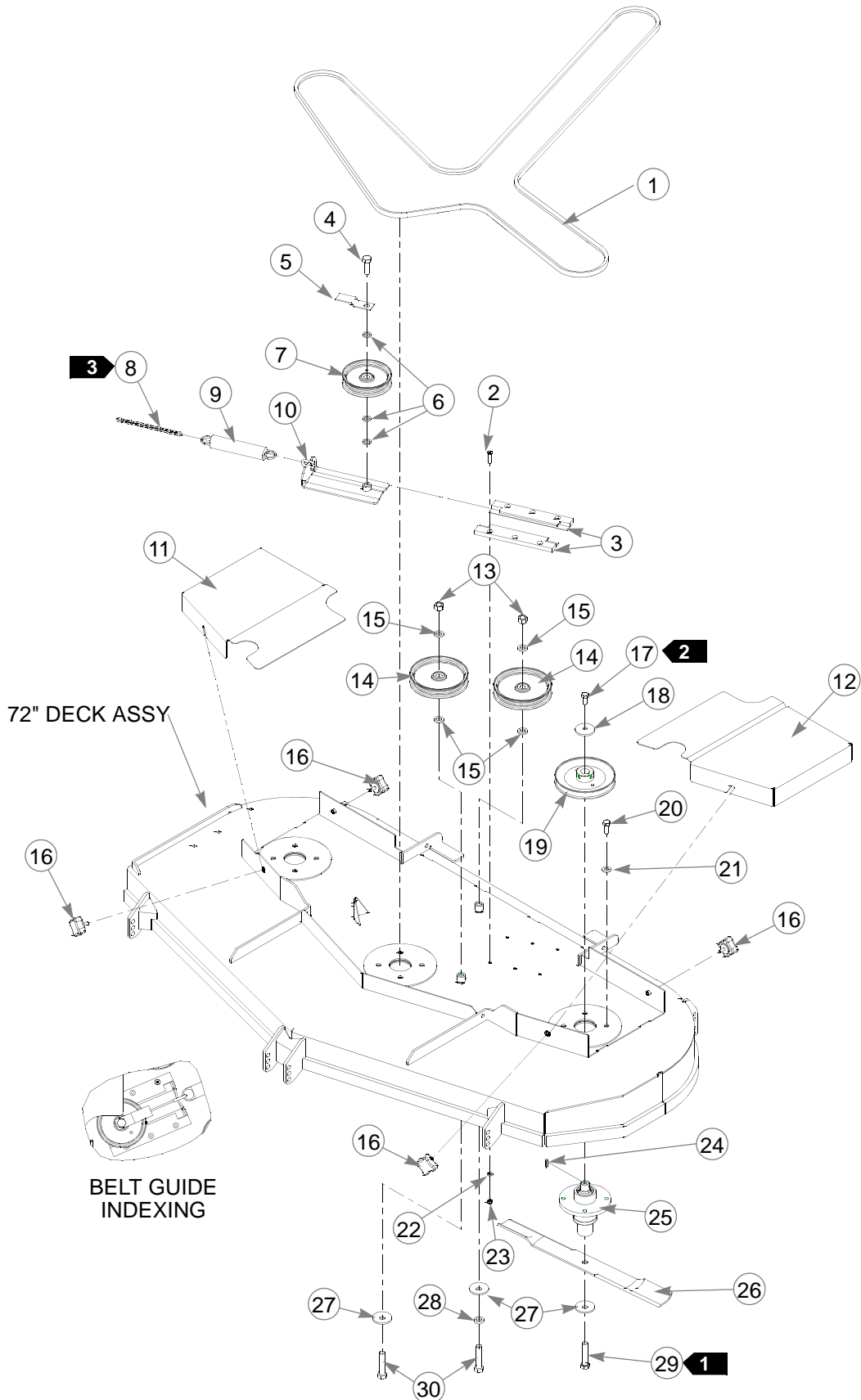

## 72" Side Discharge Deck Pulley Assembly (XR7)

ITEM NO.	SERVICE PART NO.	MFG. PART NO.	QTY	DESCRIPTION
1	784207	784207	1	B-SECTION BELT
2	797910	797910	6	CS .312 - 18 X 1.50 FLT SH ZNYC
3	601434	601434	2	UHMW IDLER SLIDE
4	025007	025007	1	CS .625 - 11 X 1.75 HX G5 ZNYC
5	347443	347443	1	DECK BELT IDLER GUIDE
6	028118	028118	3	FW .62 X 1.00 X .134 ZN
7	781856	781856	1	5.00" IDLER PULLEY
8	259812	059931	1	CHAIN DECK LIFT SPRING (13 LINKS)
9	781302	781302	1	IDLER SPRING
10	350884	350884	1	DECK IDLER
11	107620	107620	1	RS PULLEY COVER 72" XR7
12	107621	107621	1	LS PULLEY COVER 72" XR7
13	016972	016972	2	NT .625 - 11 HX G5 ZNYC
14	781385	781385	2	6.00" IDLER PULLEY
15	797449	797449	4	FW .650 X 1.125 X .18 ZNYCG5
16	792002	792002	4	5/16 - 18 X 3/4" MALE KNOB
17	016527	016527	3	CS .500 -13 X 1.00 HX G5 ZN
18	752386	752386	3	CW .515 X 2.25 X .204 ZN
19	538850	538850	3	DRIVE PULLEY DB-112
20	705954	705954	12	CS .500-13 X 1.25 HX G5 ZNYC
21	767962	767962	12	FW .531 X 1.063 X .090 SAE HD ZN
22	768523	768523	6	FW .343 X .687 X .051/.080 HD ZN
23	058776	058776	6	NT .312 -18 HXZY NL
24	212472	212472	3	KEY 1/4 SQ X 1.00 LONG
<b>4</b>	796235X	796235	3	SPINDLE HOUSING ASSEMBLY
26	798702	798702	3	BLADE, F24.50" -H-F-CW
27	782474	782474	5	CW .631 2.250 X .187 PNT
28	769257	769257	1	FW .656 X 1.250 X .250 ZNYC
29	029934	029934	3	CS .625 -11 X 3.00 HX G5 ZNYC
30	783738	783738	2	CS .625-11 X 3.00 FULL HX G5 ZN

### NOTES:

1. Torque to 118 ft. lbs.
2. Torque to 67-75 ft. lbs.
3. See "72" Side Discharge Belt Routing and Tensioning" on page 9-4 for belt tensioning.
4. See "Spindle Assembly-796235" on page 8-16 for breakdown.

# 60" Side Discharge Deck Assembly

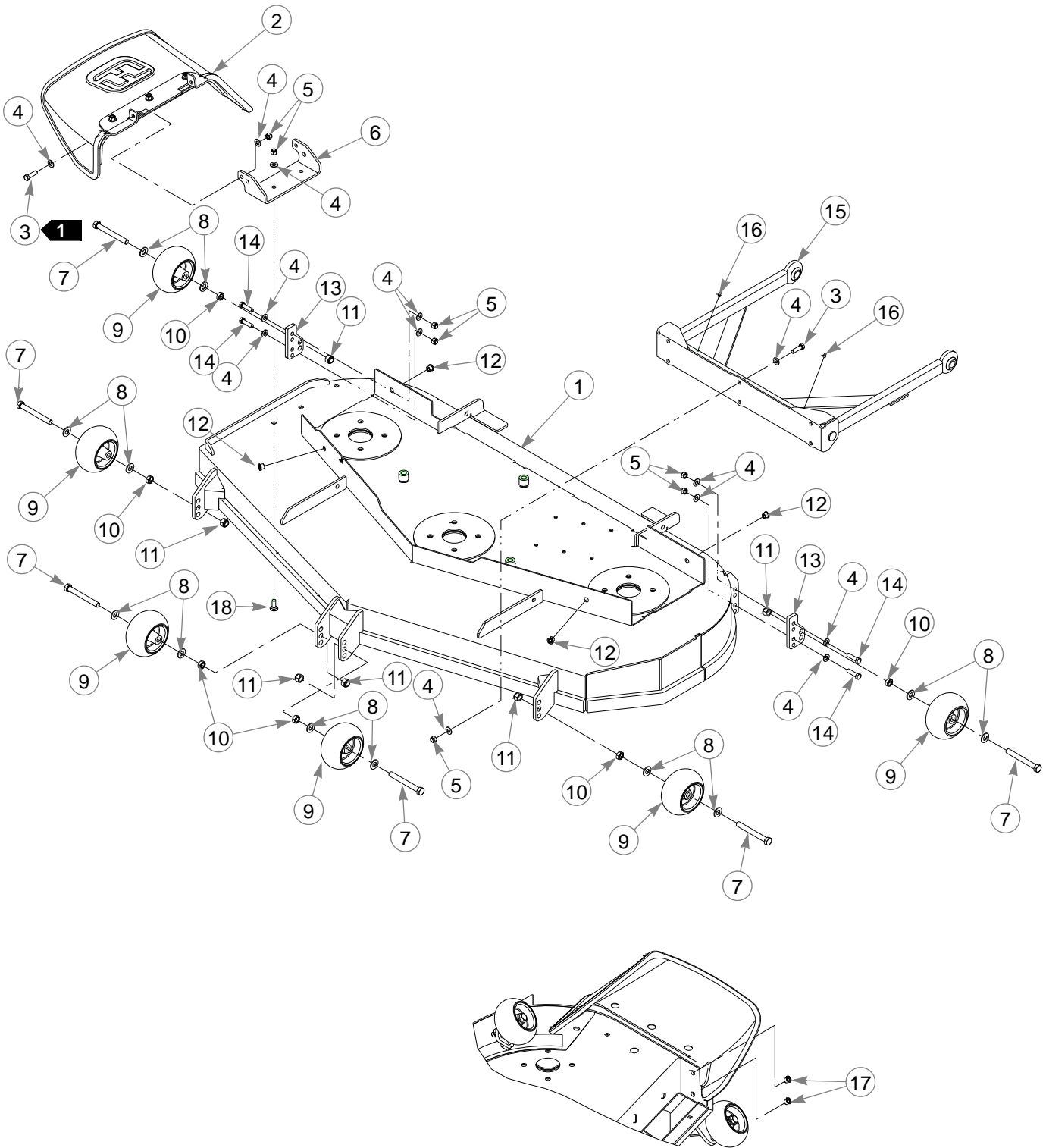

---

## **60" Side Discharge Deck Assembly**

ITEM NO.	SERVICE PART NO.	MFG. PART NO.	QTY.	DESCRIPTION
<b>3</b> 1	548438	108501	1	60" DECK W/A CRATED
2	798694	798694	1	RUBBER CHUTE ASSEMBLY
3	052860	052860	8	CS .375-16 X 1.25 HX G5
4	767954	767954	26	FW .406 X .812 X .060 SAE HD ZN
5	086660	086660	14	NT .375-16 HX LK NY
6	103010	103010	1	DISCHARGE CHUTE MOUNT BRACKET
7	781708	N/A	6	CS .500-13 X 4.25 HX G5 ZN
8	767962	N/A	12	FW .531 X 1.063 X .090 SAE HD ZN
9	031997	N/A	6	ANTI-SCALP WHEEL
10	053199	N/A	6	NT .500-13 HX JAM ZN
11	781567	781567	6	NT .50-13 HX LK NY
12	808485	808485	4	5/16-18 THREAD RIVET NUT
13	103184	103184	2	REAR ANTI-SCALP BRACKET
14	005116	005116	4	CS .375-16 X 1.375 HX G5 ZNYC
15	314104	314104	1	PUSHER
16	015495	015495	2	STRAIGHT GREASE FITTING
17	808493	808493	2	3/8-16 THREAD RIVET NUT
18	025395	025395	2	CB .375-16 X 1.00 STD CD
<b>2</b>	788166	788166	4	ANTI SCALP WHEEL ASSY

---

### **NOTES:**

1. Do not torque, Item 2 (798694 Discharge Chute) must pivot freely.
2. Includes items 7, 8, 9, and 10.
3. Service part deck includes decals (see "72" & 60" Side Discharge Deck Decals(XR7)" on page 10-4 for listing of decals).

# 60" Side Discharge Deck Pulley Assembly (XR7)

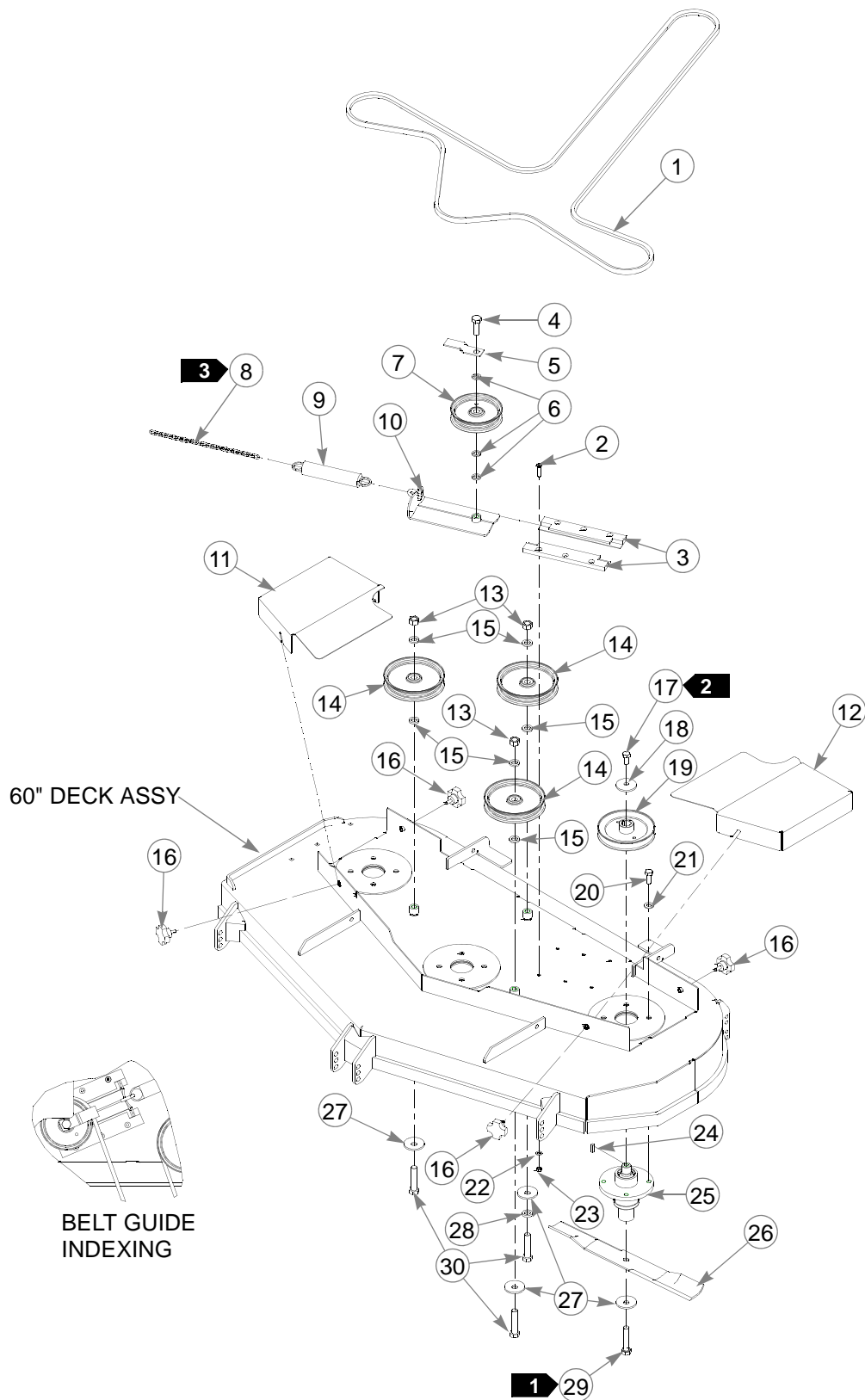



## **60" Side Discharge Deck Pulley Assembly (XR7)**

ITEM NO.	SERVICE PART NO.	MFG. PART NO.	QTY	DESCRIPTION
1	797720	797720	1	B-SECTION BELT
2	797910	797910	6	CS .312-18 X 1.50 FLT SH ZNYC
3	601434	601434	2	UHMW IDLER SLIDE
4	025007	025007	1	CS .625-11 X 1.75 HX G5 ZNYC
5	347443	347443	1	DECK BELT IDLER GUIDE
6	028118	028118	3	FW .62 X 1.00 X.134 ZN
7	781856	781856	1	5.00" IDLER PULLEY
8	373191	059931	1	SIDE MOUNT CHAIN (21 LINKS)
9	781302	781302	1	IDLER SPRING
10	350884	350884	1	DECK IDLER
11	103192	103192	1	RS 60" XR7 PULLEY COVER
12	103200	103200	1	LS 60" XR7 PULLEY COVER
13	016972	016972	3	NT .625-11 HX G5 ZNYC
14	781385	781385	3	6.00" IDLER PULLEY,
15	797449	797449	6	FW .650 X1.125 X.18 ZNYCG5
16	792002	792002	4	5/16-18 X 3/4"MALE KNOB
17	016527	016527	3	CS .500-13 X 1.00 HX G5 ZN
18	752386	752386	3	CW .515 X 2.25 X .204 ZN
19	770842	770842	3	DECK DRIVE PULLEY
20	705954	705954	12	CS .500-13 X 1.25 HX G5 ZNYC
21	767962	767962	12	FW .531 X 1.063 X .090 SAE HD ZN
22	768523	768523	6	FW .343 X .687 X .051/.080 HD ZN
23	058776	058776	6	NT .312-18 HXZY NL
24	212472	212472	3	KEY 1/4 SQ X 1.00 LONG
<b>4</b>	796235X	796235	3	SPINDLE HOUSING ASSEMBLY
26	794685	794685	3	BLADE, F20.50" H-F-CW
27	782474	782474	6	CW .631 2.250 X .187 PNT
28	769257	769257	1	FW .656 X 1.250X.250 ZNYC
29	029934	029934	3	CS .625-11 X 3.00 HX G5 ZNYC
30	783738	783738	3	CS .625-11 X 3.00 FULL HX G5 ZN

### **NOTES:**

1. Torque to 118 ft. lbs.
2. Torque to 65-75 ft. lbs.
3. See "60" Side Discharge Belt Routing and Tensioning" on page 9-5 for belt tensioning.
4. See "Spindle Assembly-796235" on page 8-16 for breakdown.

# Side Discharge Deck—"A" Adaptors

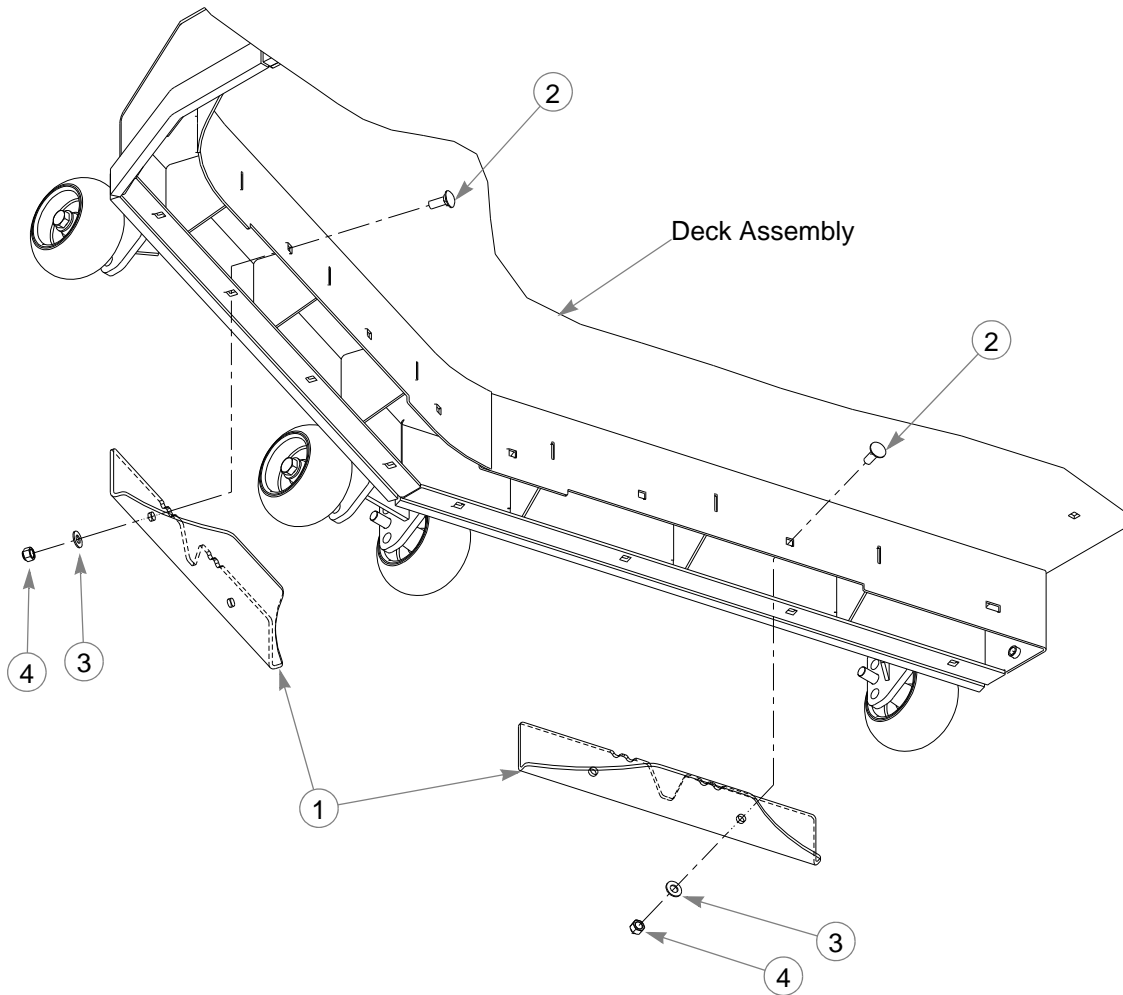

---

## **Side Discharge Deck—"A" Adaptors**

ITEM NO.	SERVICE PART NO.	MFG. PART NO.	QTY.	DESCRIPTION
1	108661	108661	2	AIR FLOW FLOOR (72" DECKS)
	108516	108516	2	AIR FLOW FLOOR (60" DECKS)
2	025395	025395	4	CB .375-16X 1.00 STD CD
3	767954	767954	4	FW .406X .812 X.060 SAE
4	086660	086660	4	NT .375-16 HXZY NL

---

### **NOTES:**

# 60" Rear Discharge Deck Assembly

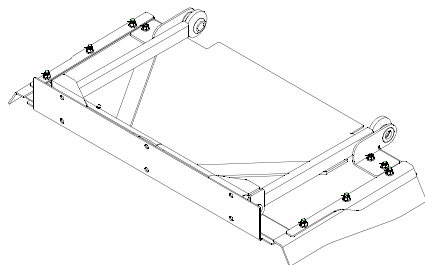
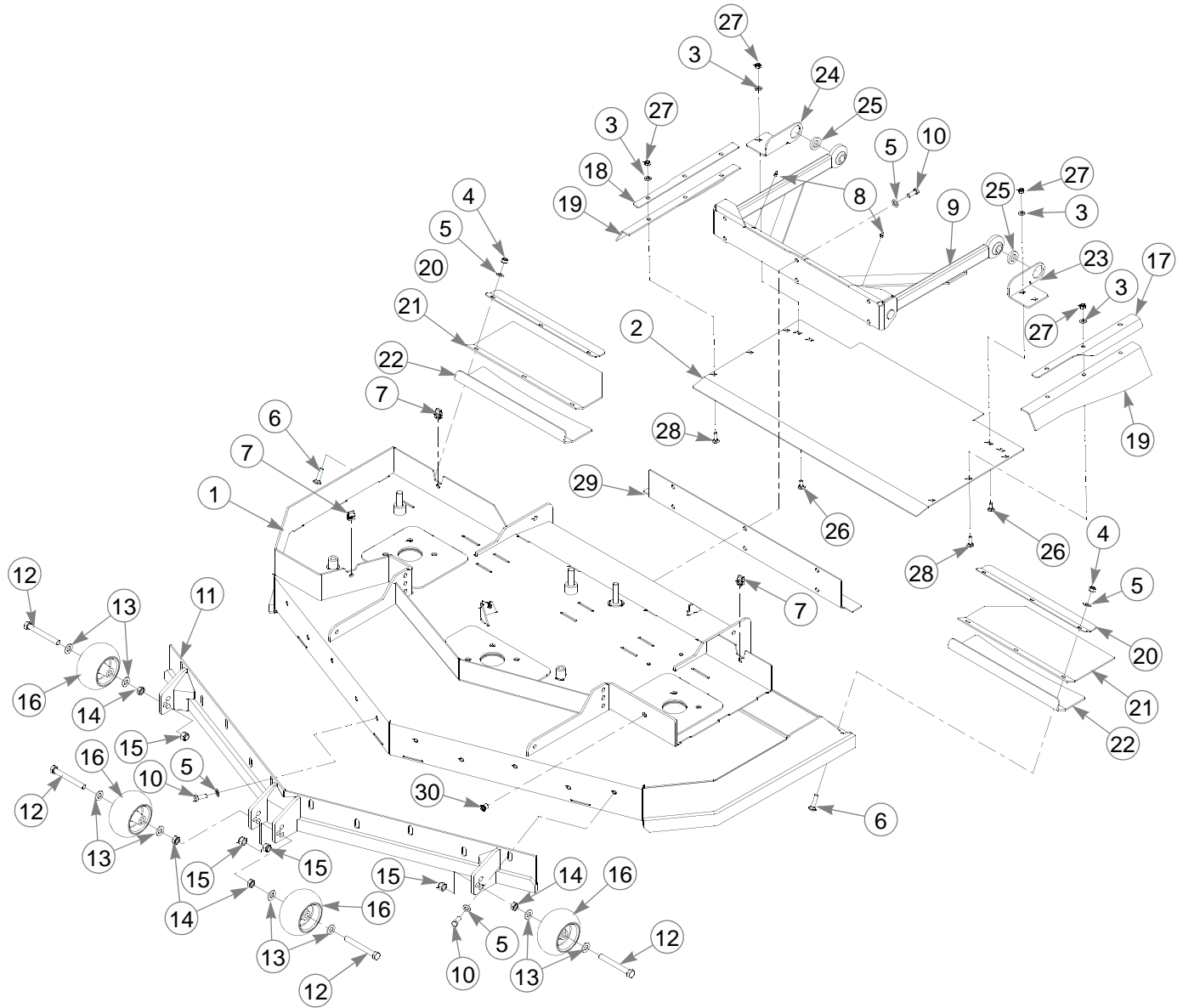

DEFLECTOR DETAIL

# 60" Rear Discharge Deck Assembly

ITEM NO.	SERVICE PART NO.	MFG. PART NO.	QTY.	DESCRIPTION
<b>3</b> 1	549576	110402	1	60" REAR DISCHARGE DECK
2	109484	109484	1	DISCHARGE SHIELD
3	768523	768523	10	FW .343 X .687 X .051/.080 HD ZN
4	086660	086660	6	NT .375-16 HX LK NY
5	767954	767954	22	FW .406 X .812 X .060 SAE HD ZN
6	710194	710194	6	CB .375-16 X 1.50 STD G5
7	601069	601069	3	CN .312-18X.200
8	015495	015495	2	STRAIGHT GREASE FITTING
9	349803	349803	1	PUSHER
10	036244	036244	16	CS .375-16 X 1.00 HX G5 ZN
11	352591	352591	1	60" REAR DISCHARGE FRONT ANGLE
12	781708	N/A	4	CS .500-13 X 4.25 HX G5 ZN
13	767962	N/A	8	FW .531 X 1.063 X .090 SAE HD ZN
14	053199	N/A	4	NT .500-13 HX JAM ZN
15	781567	781567	4	NT .50-13 HXZY NL
16	031997	N/A	4	ANTI-SCALP WHEEL
17	109486	109486	1	CLAMP ANGLE LS
18	109487	109487	1	CLAMP ANGLE RS
19	601483	601483	2	SIDE FLAP RUBBER
20	106716	106716	2	ANGLE, DISCHARGE CHUTE
21	600254	600254	2	RD REAR FLAP
22	351676	351676	2	DECK STIFFENER ANGLE
23	109482	109482	1	CHUTE BRACKET RS
24	109483	109483	1	CHUTE BRACKET LS
25	778399	778399	2	FW .781 X 1.375 X .250 ZNYC
26	016253	016253	4	CB .312-18 X .750 FUL ZN
27	058776	058776	10	NT .312-18 HXZY NL
28	037887	037887	6	CB .312-18 X 1.000 FUL Z
29	109485	109485	1	GUARD MTG ANGLE
30	792887	792887	1	5/16-18 HX TH RIVET NUT
<b>1</b> <b>2</b>	788166	788166	4	ANTI SCALP WHEEL ASSEMBLY

## NOTES:

1. Factory assembled in top hole for shipping purposes.
2. Includes Items 12 through 14 and 16.
3. Service part deck includes decals, see "72" & 60" Side Discharge Deck Decals(XR7)" on page 10-4.

# 60" Rear Discharge Deck Pulley Assembly

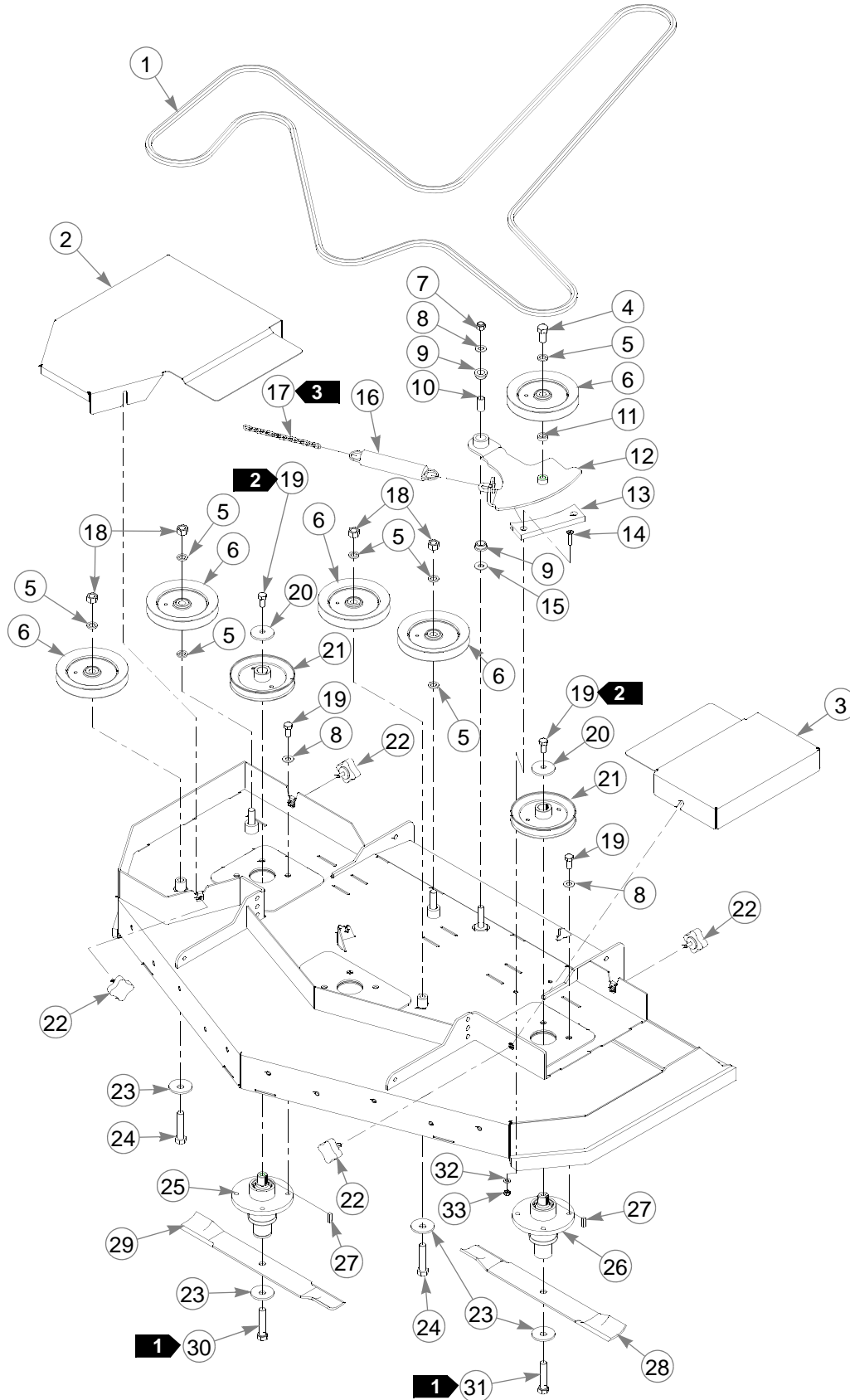

# 60" Rear Discharge Deck Pulley Assembly

ITEM NO.	SERVICE PART NO.	MFG. PART NO.	QTY.	DESCRIPTION	
1	795781	795781	1	60" REAR DISCHARGE DECK BELT	
2	110411	110411	1	PULLEY COVER, RH,60"	
3	110412	110412	1	PULLEY COVER, LH,60"	
4	794446	794446	1	CS .625-11X1.500 HX G5 Z	
5	028118	028118	7	FW .62 X 1.00 X .134 ZN	
6	796714	796714	5	6" HB IDLER PULLEY RD	
7	781567	781567	1	NT .500-13 HX G8 ZY NL	
8	767962	767962	13	FW .531 X 1.063 X .090 SAE HD ZN	
9	770867	770867	2	BUSHING, PLAS .750X1(FS)	
10	109549	109549	1	BUSHING, IDLER PIVOT	
11	600296	600296	1	DECK IDLER SPACER	
12	109948	109948	1	IDLER ARM W/A	
13	601779	601779	1	IDLER SLIDE UHMW	
14	797910	797910	2	CS .312-18X1.50FLT SH ZY	
15	704759	704759	1	FW .500X 1.250X.075 ZNY	
16	781302	781302	1	IDLER SPRING	
17	259812	059931	1	DECK LIFT CHAIN (13 LINKS)	
18	016972	016972	4	NT .625-11 HX G5 ZNYC	
19	016527	016527	15	CS .500-13 X 1.00 HX G5 ZN	
20	752386	752386	3	FW .510 X 1.75 X .18 ZN	
21	770842	770842	3	B-SECTION PULLEY	
22	792002	792002	4	5/16-18 X 3/4" MALE KNOB	
23	782474	782474	5	CW .631 X 2.250 X .187 PNT	
24	783738	783738	2	CS .625-11X3.00 FULL HX G5 ZN	
<b>5</b>	25	796680X	796680	1	REAR DISCHARGE DECK SPINDLE ASSEMBLY
<b>4</b>	26	796235X	796235	2	DECK SPINDLE ASSY
27	212472	212472	3	KEY 1/4 SQ X 1.00 LONG	
28	600901	600901	2	BLADE, F20.50"-L-F-CW	
29	795633	795633	1	BLADE, F20.50"-L-F-CCW	
30	796722	796722	1	CS .625-11 X 3.00 LH HX G	
31	029934	029934	2	CS .625-11 X 3.00 HX G5 ZNYC	
32	768523	768523	1	FW .343X.687X.051/.080H	
33	058776	058776	1	NT .312-18 HXZY NL	

## NOTES:

1. Torque to 118 ft. lbs.
2. Torque to 65-75 ft. lbs.
3. See "60" Rear Discharge Belt Routing and Tensioning" on page 9-6 for belt tensioning.
4. See "Spindle Assembly-796235" on page 8-16 for breakdown.
5. See "Spindle Assembly-796680" on page 8-17 for breakdown.

## Spindle Assembly-796235

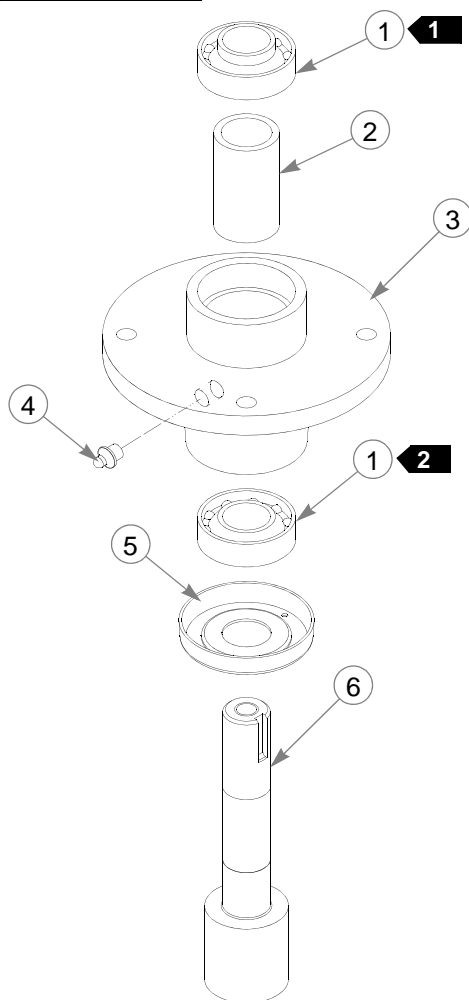

ITEM NO.	SERVICE PART NO.	MFG. PART NO.	QTY.	DESCRIPTION
1	077123	N/A	2	BEARING W/O COLLAR
2	766204	N/A	1	BLADE SPINDLE BUSHING
3	034843	N/A	1	CAST SPINDLE HOUSING
4	012005	N/A	1	GREASE FITTING
5	072272	N/A	1	FW 1.06 X 2.00 X.134 SAE ZN
6	796227	N/A	1	SADDLELESS SPINDLE SHAFT

### NOTES:

1. Install upper bearing with extended inner race up.
2. Install lower bearing with extended inner race down.



## Spindle Assembly-796680

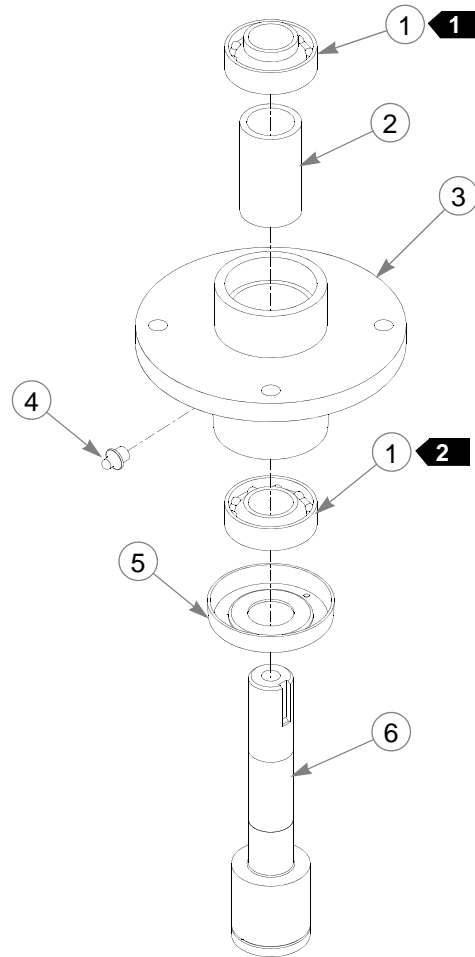

ITEM NO.	SERVICE PART NO.	MFG. PART NO.	QTY.	DESCRIPTION
1	077123	N/A	2	BEARING W/O COLLAR
2	766204	N/A	1	BLADE SPINDLE BUSHING
3	034843	N/A	1	CAST SPINDLE HOUSING
4	012005	N/A	1	GREASE FITTING
5	600893	N/A	1	BEARING DUST COVER
6	796698	N/A	1	SPINDLE SHAFT

### NOTES:

1. Install upper bearing with extended inner race up.
2. Install lower bearing with extended inner race down.



---

## Chapter 9 Contents

Deck Installation . . . . .	9-2
72" Side Discharge Belt Routing and Tensioning . . . . .	9-4
60" Side Discharge Belt Routing and Tensioning . . . . .	9-5
60" Rear Discharge Belt Routing and Tensioning . . . . .	9-6



---

## **Deck Installation**

<b>ITEM NO.</b>	<b>SERVICE PART NO.</b>	<b>MFG. PART NO.</b>	<b>QTY</b>	<b>DESCRIPTION</b>
1	055749	055749	4	CS .437-14 X 1.750 HX G5 ZN
2	061101	061101	2	NT .750-10 HX NL ZN
3	025296	025296	4	FW .760 X 1.625 X.08 ZN
4	051169	051169	2	CS .750-10 X 3.000 HX G5 ZN
5	704643	704643	8	NT .437-14 HX FLG ZN

---

### **NOTES:**

1. 60" Side Discharge Deck installation is shown, 72" Side Discharge Deck and 60" Rear Discharge Deck installation are similar.

## **72" Side Discharge Belt Routing and Tensioning**

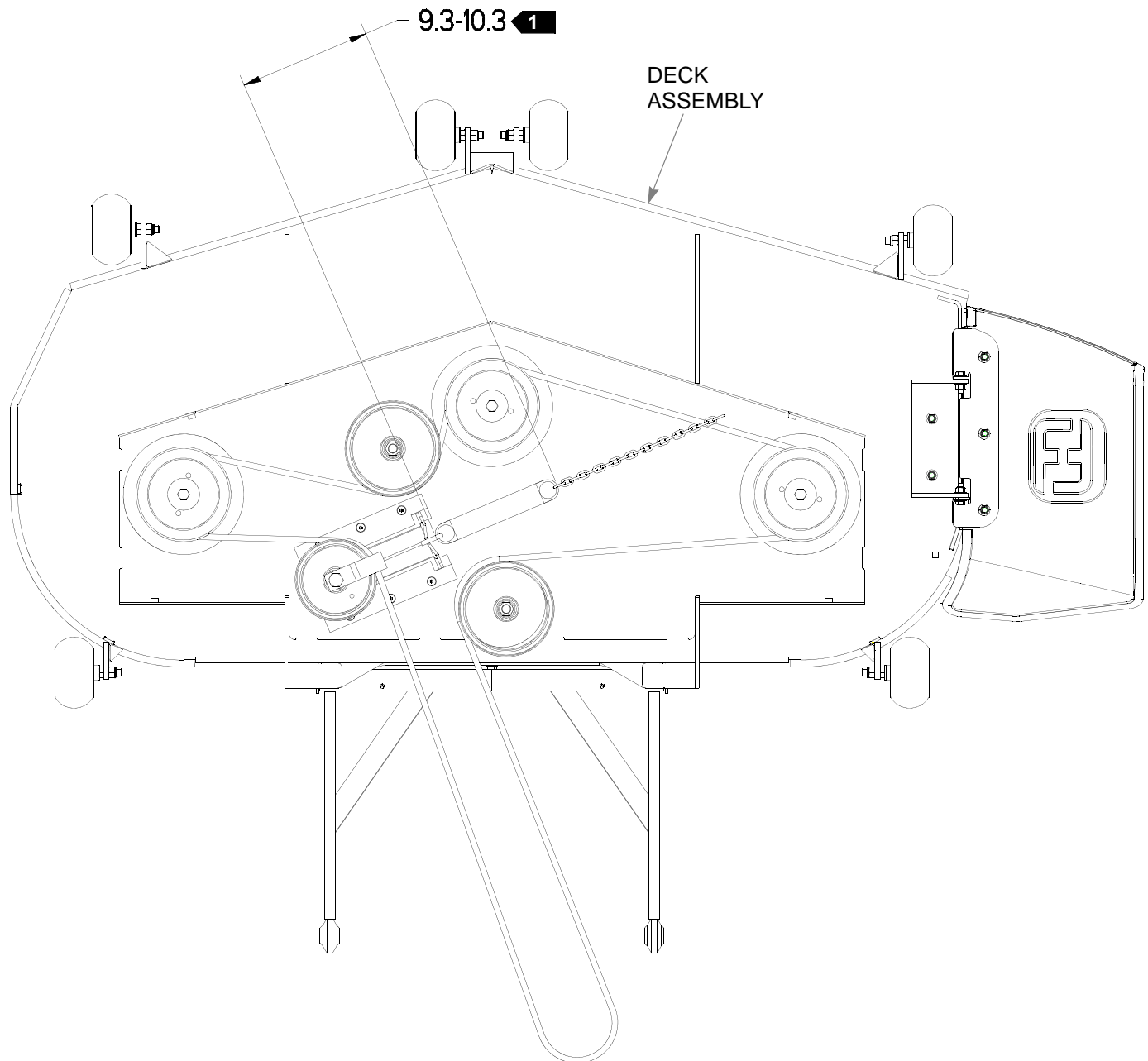

### **NOTES:**

1. Spring length after tensioning belt. Measure spring from outside of hook to outside of hook.
2. Route belt as shown.

## **60" Side Discharge Belt Routing and Tensioning**

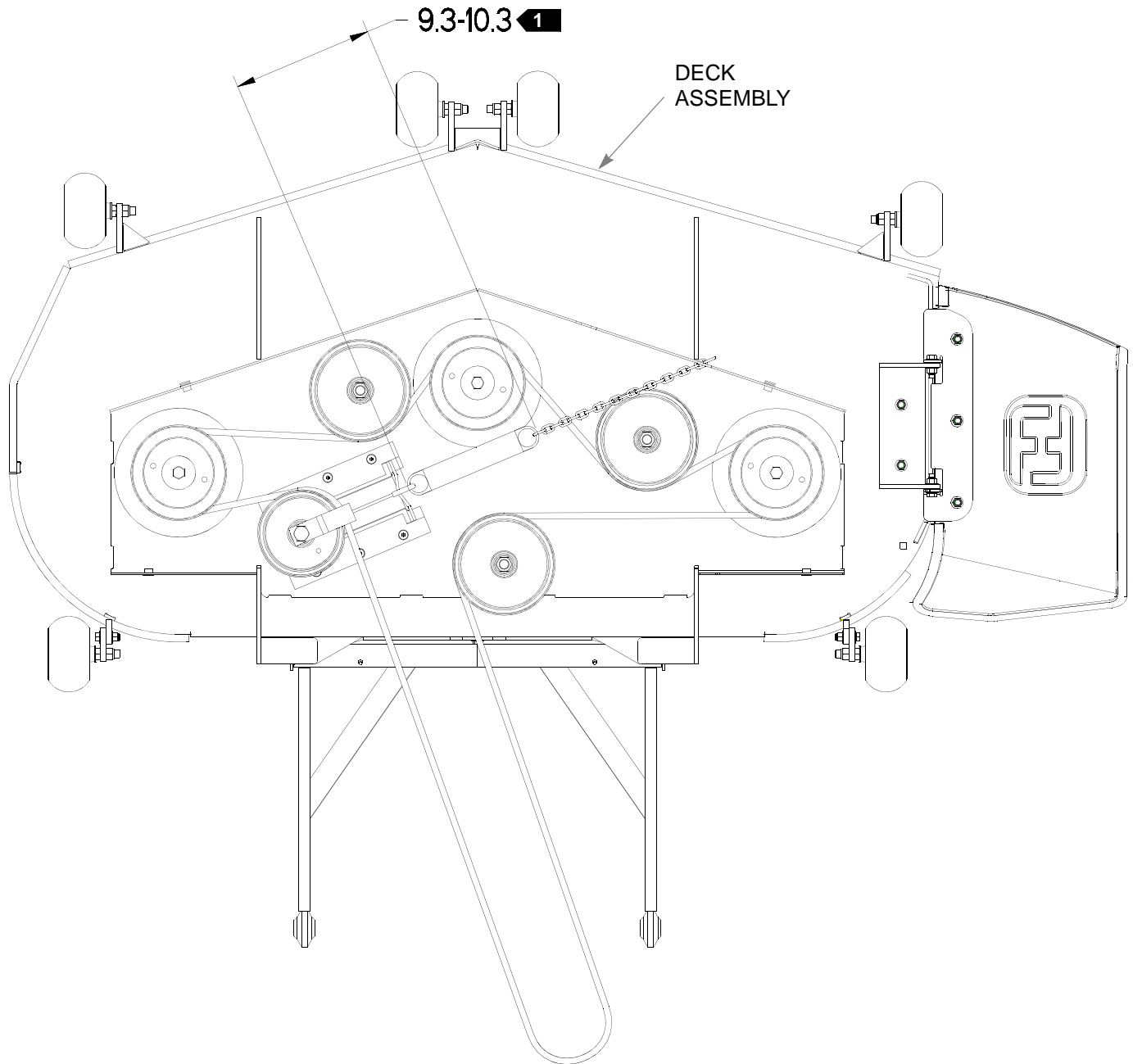

### **NOTES:**

1. Spring length after tensioning belt. Measure spring from outside of hook to outside of hook.
2. Route belt as shown.

---

## **60" Rear Discharge Belt Routing and Tensioning**

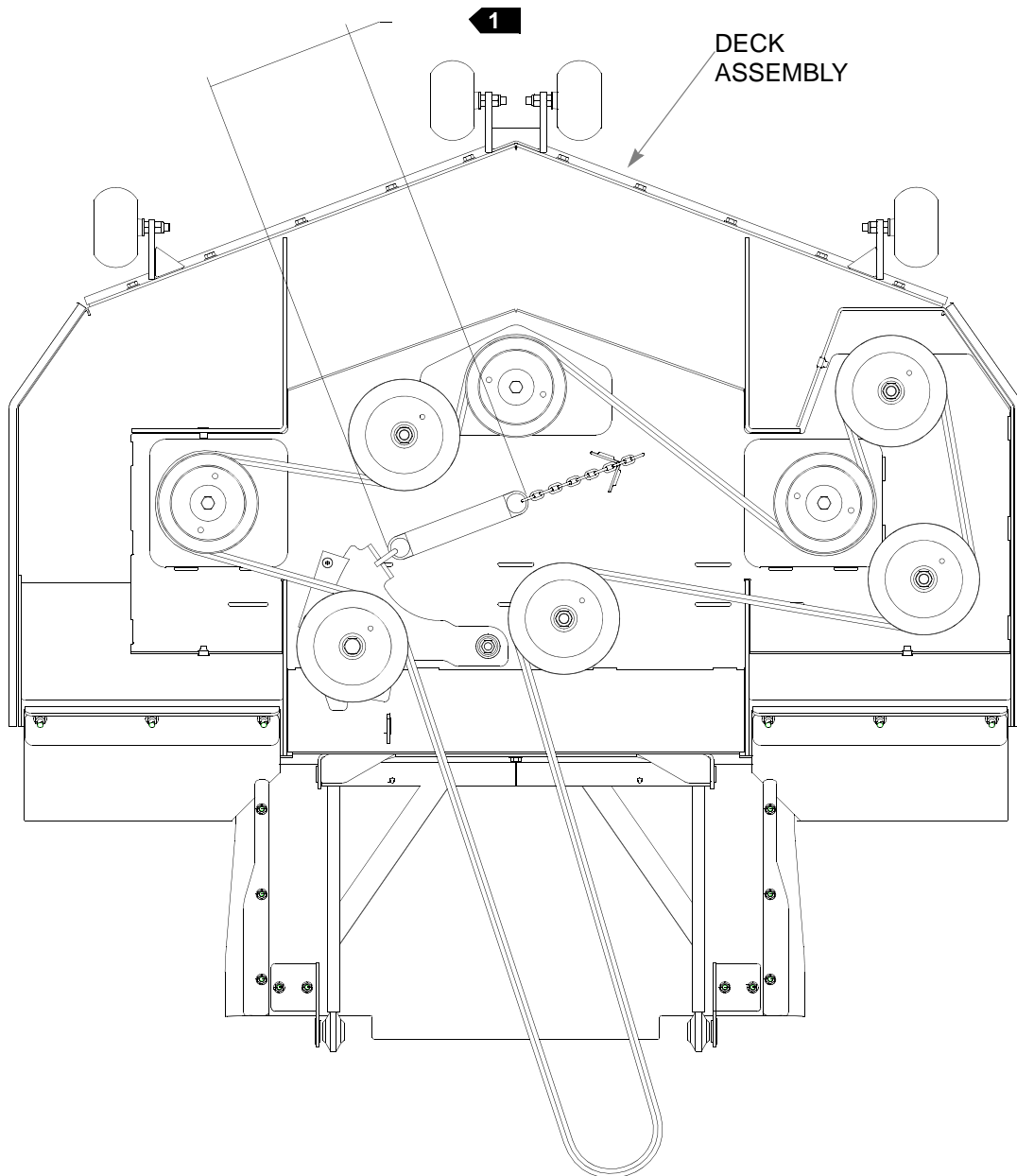

---

### **NOTES:**

1. Spring length after tensioning belt. Measure spring from outside of hook to outside of hook.
2. Route belt as shown.



---

## Chapter 10 Contents

Tractor Decals . . . . .	10-2
72" & 60" Side Discharge Deck Decals(XR7) . . . . .	10-4
60" Rear Discharge Deck Decals . . . . .	10-5

# Tractor Decals

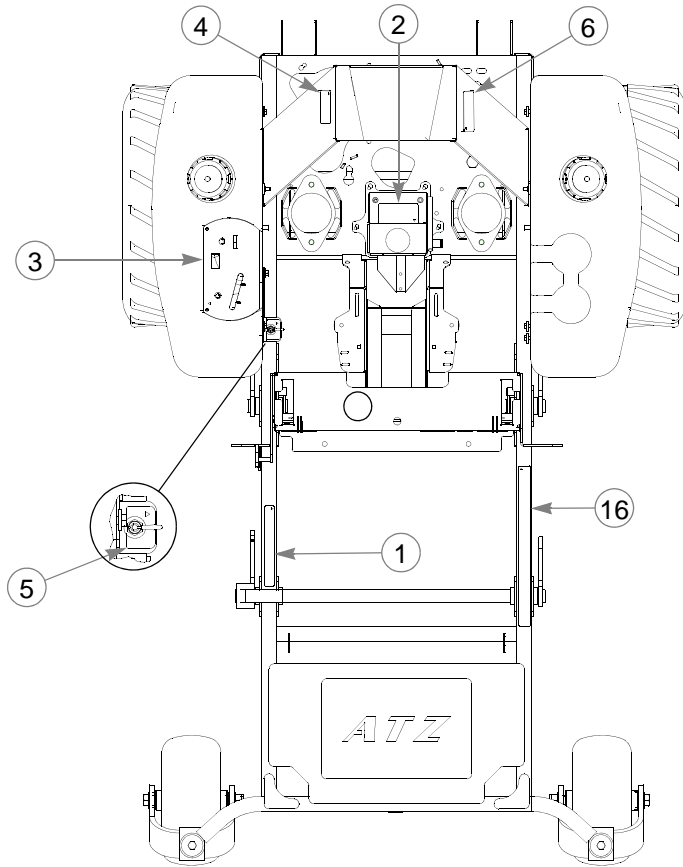

TOP OF  
SEAT PAN

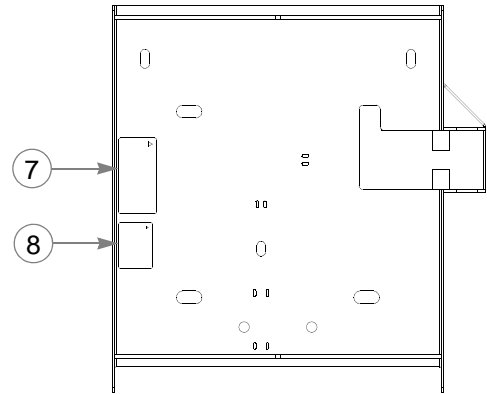

BOTTOM OF  
SEAT PAN

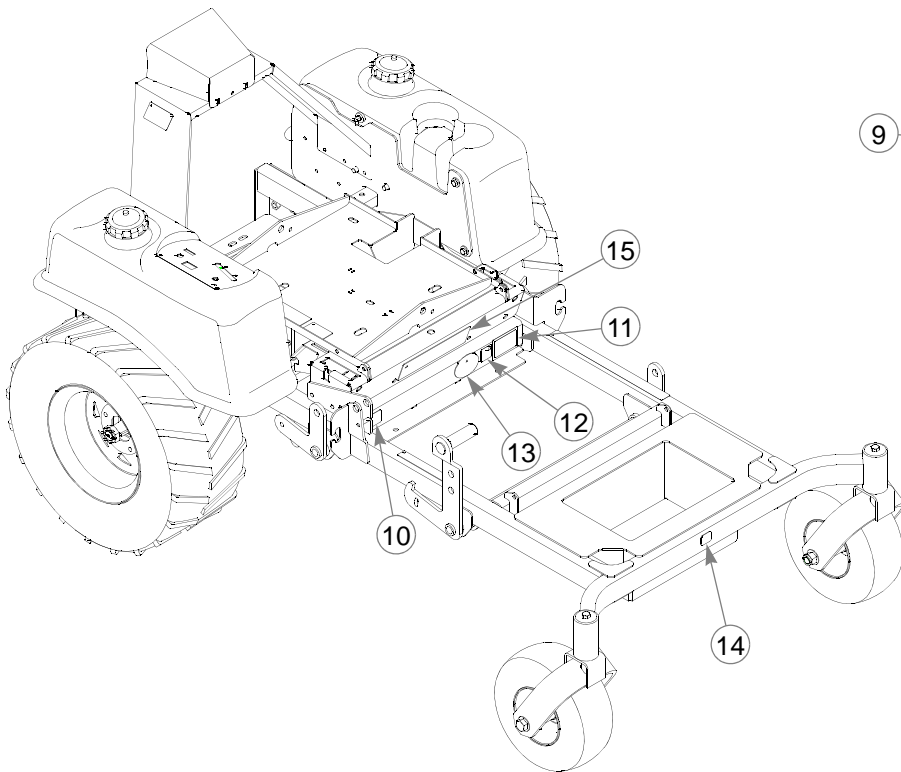
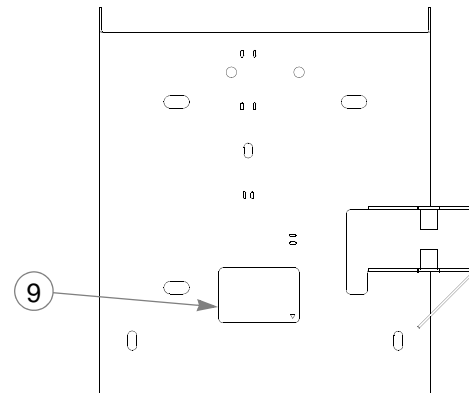

---

## **Tractor Decals**

<b>ITEM NO.</b>	<b>SERVICE PART NO.</b>	<b>MFG. PART NO.</b>	<b>QTY.</b>	<b>DESCRIPTION</b>
1	781427	781427	1	DECK HEIGHT INDICATOR DECAL
2	779280	779280	1	HOT & HYDRAULIC OIL DECAL
3	601980	601980	1	INSTRUMENT PANEL DECAL
4	601968	601968	1	HYD PRESSURE DECAL
5	791830	791830	1	FUEL INDICATOR DECAL
6	601967	601967	1	ENGINE COMPARTMENT DECAL
7	600899	600899	1	PUMP BELT WARNING DECAL
8	785188	785188	1	Z ARMREST WARNING DECAL
9	601815	601815	1	BATTERY DECAL
10	600941	600941	1	PATENTS DECAL
11	N/A	083279	1	TURF PRODUCT SERIAL NO PLATE
12	727172	727172	1	MADE IN USA DECAL
13	782573	782573	1	FIRST ZERO TURN DECAL
14	793588	793588	1	HUSTLER NAME PLATE
15	782615	782615	1	SUPER Z ID DECAL
16	601791	601791	1	ATZ SAFETY DECAL

---

### **NOTES:**

## **72" & 60" Side Discharge Deck Decals(XR7)**

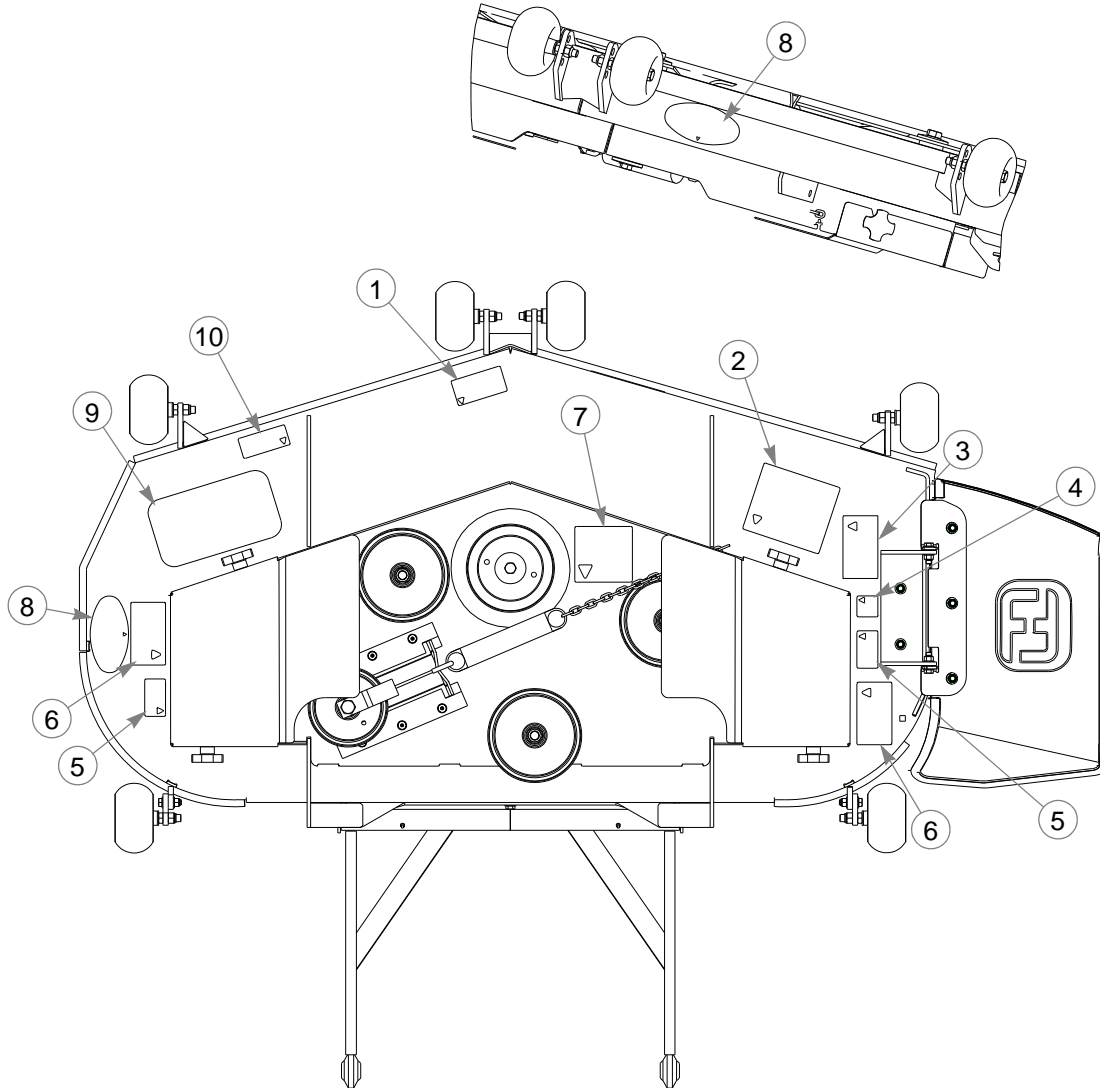

INDEX NO.	SERVICE PART NO.	MFG. PART NO.	QTY.	DESCRIPTION
1	786285	786285	1	72" SIDE DISCHARGE DECK ID DECAL
	786277	786277	1	60" SIDE DISCHARGE DECK ID DECAL
2	760637	760637	1	MOWER DECK QUICK REFERENCE DECAL
3	727420	727420	1	DEFLECTOR SHIELD DECAL
4	727172	727172	1	"MADE IN U.S.A." DECAL
5	727453	727453	2	BELT & PULLEY DECAL
6	727438	727438	2	WHIRLING BLADES DECAL
	799395	799395	1	BELT ROUTING DECAL (60" DECK ONLY)
7	781419	781419	1	BELT ROUTING DECAL (72" DECKS)
	799353	799353	2	DECK XR7 ID DECAL
9	359547	359547	1	5.00 X 9.00 STEP TREAD
10	797845	797845	1	FUSION DECAL

## 60" Rear Discharge Deck Decals

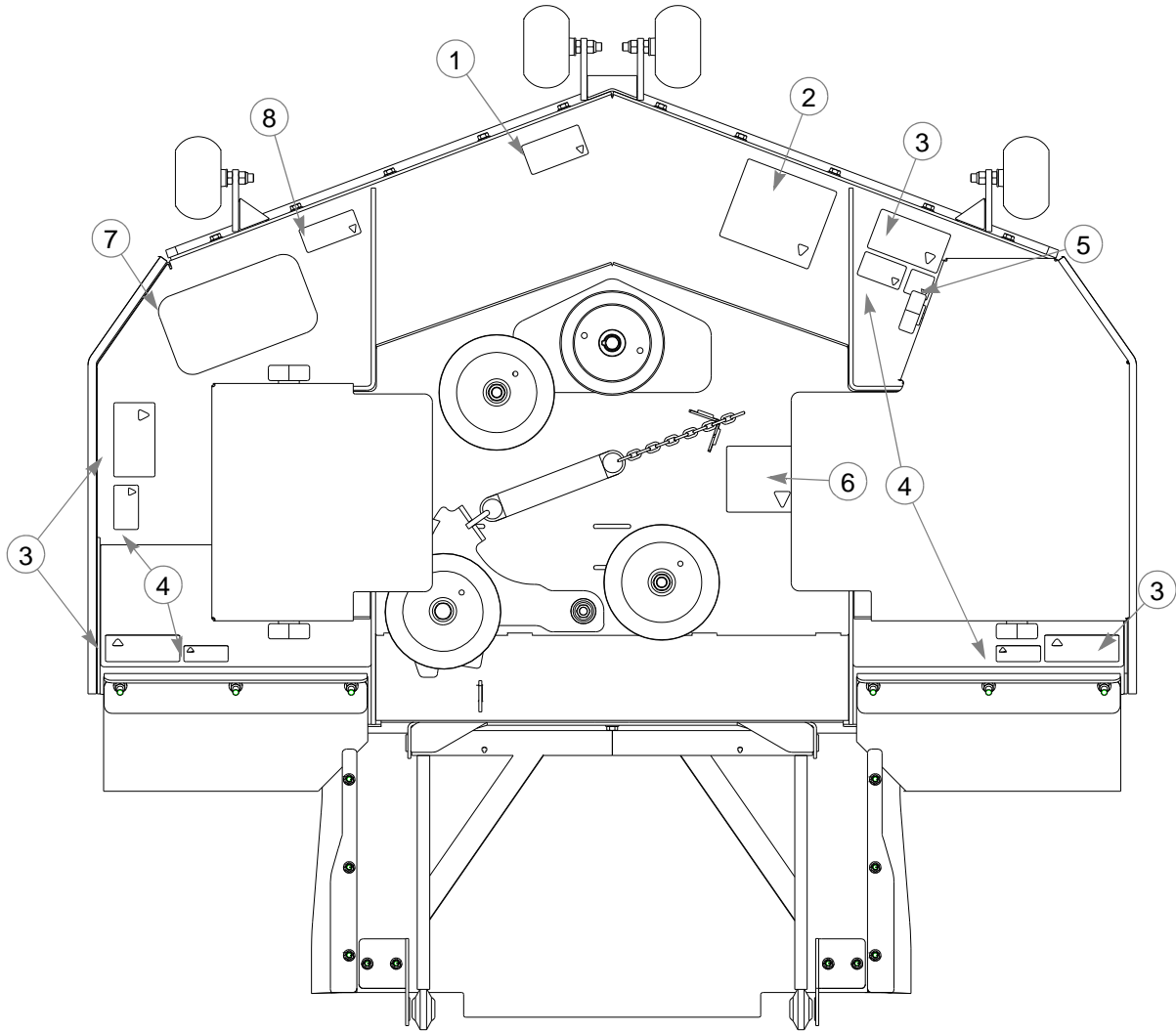

INDEX NO.	SERVICE PART NO.	MFG. PART NO.	QTY.	DESCRIPTION
1	786277	786277	1	60" DECK ID DECAL
2	760637	760637	1	MOWER DECK QUICK REFERENCE DECAL
3	727438	727438	4	WHIRLING BLADES DECAL
4	727453	727453	4	BELT & PULLEY DECAL
5	727172	727172	1	"MADE IN U.S.A." DECAL
6	796953	796953	1	REAR DISCHARGE DECK ROUTING DECAL
7	359547	359547	1	5.00 X 9.00 STEP TREAD
8	797845	797845	1	FUSION DECAL

### NOTES:



---

## Chapter 11 Contents

Seat Installation .....	11-2
-------------------------	------

# Seat Installation

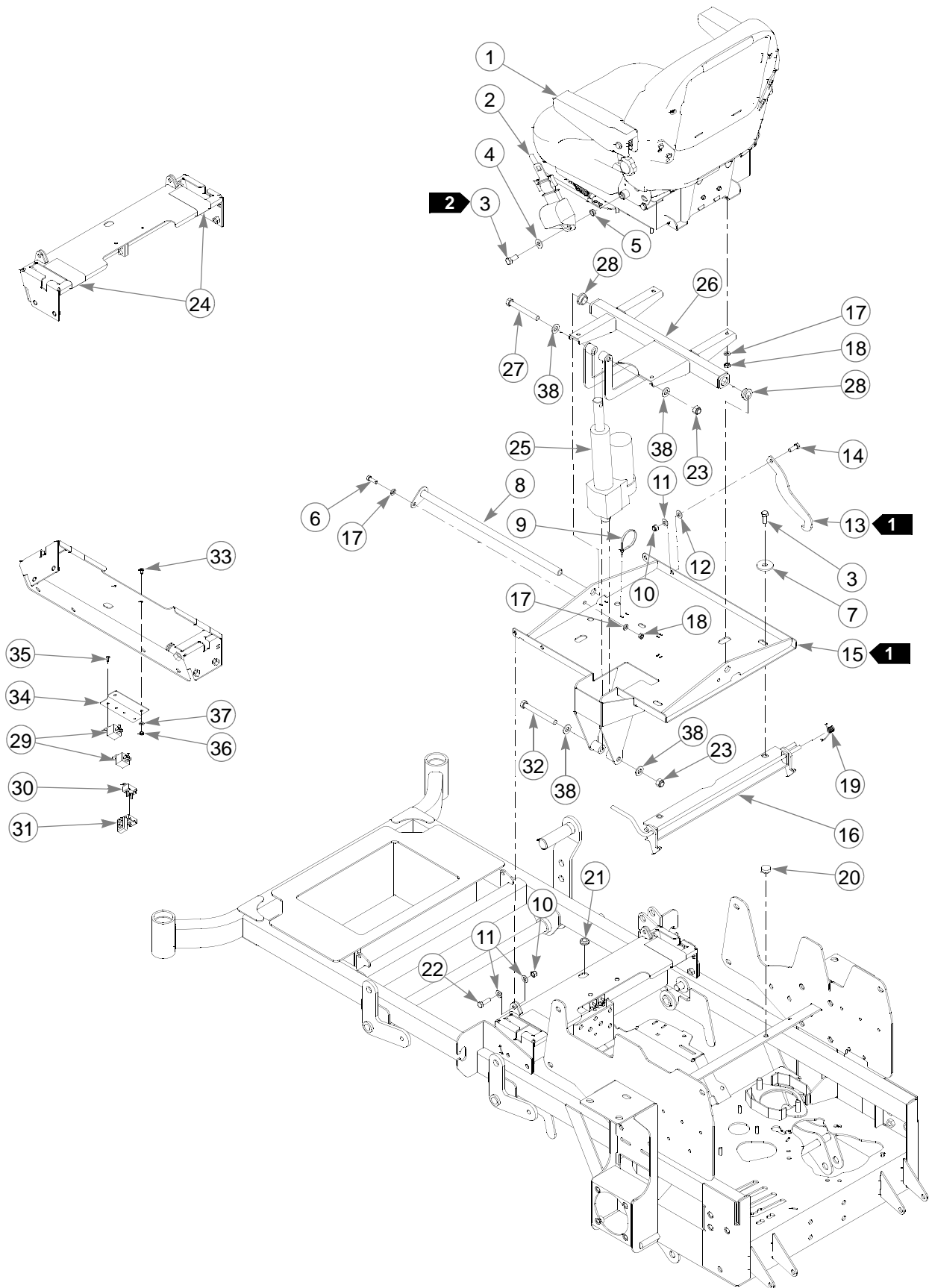



# Seat Installation

ITEM NO.	SERVICES PART NO.	MFG. PART NO.	QTY	DESCRIPTION
1	792051	792051	1	SUSPENSION SEAT
2	784140	784140	1	SEAT BELT
3	797076	797076	4	CS .437-20 X 1.00 HX G8 ZNYC
4	728147	728147	2	FW .468 X 1.00 X .090 HT T ZNYC
5	746131	746131	2	SPACER, .493 X .675 X .250
6	036236	036236	1	CS .312-18X1.000 HX G5
7	078386	078386	2	FW .510 X 1.750 X .18 ZNYC
8	110686	110686	1	TILTSEAT PIVOT TUBE
9	000331	000331	2	BLACK CABLE TIE
10	086660	086660	3	NT .375-16 HX LK NY
11	767954	767954	6	FW .406 X .812 X .060 SAE HD ZN
12	724716	724716	1	FIBER WASHER
13	350421	350421	1	SEAT PAN STOP
14	036244	036244	1	CS .375-16 X 1.00 HX G5 ZNYC
15	108291	108291	1	SEAT PAN
16	357384	357384	1	ROPS LATCH
17	768523	768523	6	FW .343 X .687 X .051/.080 HD ZN/Y
18	034272	034272	5	NT .312-18 HX G5 ZN
19	783910	783910	1	ROPS LATCH TORSION SPRING
20	781880	781880	2	BUMPER
21	080358	080358	1	GM .50 X 1.00 X .75 X .12 GROMMET
22	052860	052860	2	CS .375-16 X 1.25 HX G5 ZNYC
23	781567	781567	2	NT .500-13 HX G8 ZY NL
24	722199	722199	1	2" WIDE SCOTCH POLYURETHANE 5.55" LONG
25	601130	601130	1	ELECTRIC LINEAR ACTUATOR
26	108290	108290	1	SEAT MOUNT
27	089938	089938	1	CS .500-13X4.00 HX G5 Z
28	770867	770867	2	PLASTIC BUSHING .750X1(FS)
29	601053	601053	2	SEAL RELAY W/BACKET
30	601647	601647	1	15 AMP CIRCUIT BREAKER
31	601648	601648	1	RED CIRCUIT BREAKER BOOT
32	068239	068239	1	CS .500-13X4.500 HX G5
33	601098	601098	2	CB 10-24 X .500 ZYNC
34	110677	110677	1	RELAY MOUNT BRACKET
35	601089	601089	4	RIVET .188 DIA BLK HD
36	059832	059832	2	NT #10-24 HX NL ZN
37	704932	704932	2	FW .219 X .500 X .048 ZN
38	767962	767962	4	FW .531X 1.063X.090 SAE

## NOTES:

1. Must pivot freely.
2. Torque to 48 ft.-lbs.
3. Service parts available for Michigan suspension seat:

<u>PART NO.</u>	<u>DESCRIPTION</u>
793307	SLIDE KIT
793323	KNOB KIT
793281	BACK CUSHION KI

---

<u>PART NO.</u>	<u>DESCRIPTION</u>
793299	SEAT CUSHION KIT
793315	SEAT SWITCH
793265	MOLDED ARMREST KIT (INCLUDES BOTH ARMRESTS)
793273	ARMREST STOP ASSEMBLY

---

## Chapter 12 Contents

Maintenance & Adjustment Safety . . . . .	12-2
Safe Maintenance & Adjustment Practices . . . . .	12-2
Using a ramp . . . . .	12-4
Safety and Instruction Decals . . . . .	12-4
Maintenance . . . . .	12-5
Introduction . . . . .	12-8
Torque values . . . . .	12-8
Tires . . . . .	12-8
Hour meter . . . . .	12-9
Lubrication . . . . .	12-9
Electrical system . . . . .	12-9
Access to engine and hydraulic pumps . . . . .	12-11
Hydraulic system . . . . .	12-11
Fuel system . . . . .	12-13
Engine oil and filter . . . . .	12-14
Engine air filter . . . . .	12-15
Recommended service procedure . . . . .	12-15
Overservicing . . . . .	12-16
Improper installation of an air filter element . . . . .	12-16
Damaged filter, seals or canister . . . . .	12-16
Incorrect air cleaner element . . . . .	12-16
Recommended service procedure . . . . .	12-17
Air restriction indicator . . . . .	12-17
General engine maintenance . . . . .	12-17
Belt replacement . . . . .	12-17
Mower blade maintenance . . . . .	12-19
Mower blade removal . . . . .	12-19
Adjustment . . . . .	12-21
Introduction . . . . .	12-21
Steering linkage . . . . .	12-21
Control Lever Neutral Adjustment . . . . .	12-21

---

Control lever stops . . . . .	12-22
Steering dampener. . . . .	12-23
Control lever adjustment . . . . .	12-23
Park brake adjustment . . . . .	12-23
Hydraulic pump belt adjustment. . . . .	12-25
Deck drive belt adjustment. . . . .	12-25
Engine RPM setting . . . . .	12-26
Deck leveling and height adjustment . . . . .	12-26
Deck level adjustments . . . . .	12-26

---

# Maintenance & Adjustment Safety



This safety alert symbol is used to call attention to a message intended to provide a reasonable degree of **PERSONAL SAFETY** for operators and other persons during the normal operation and servicing of this equipment.

**DANGER** – denotes immediate hazards which **WILL** result in severe personal injury or death.

**WARNING** – denotes a hazard or unsafe practice which **COULD** result in severe personal injury or death.

This manual uses two other words to highlight information. **IMPORTANT** calls attention to special mechanical information and **NOTE**: emphasizes general information worthy of special attention.

All operators should read this manual, or be instructed about safe operating and maintenance procedures. This is the owner's responsibility.

**Improper use or maintenance by the operator, mechanic, or owner can result in injury. To reduce the potential for injury, comply with these safety instructions and always pay attention to the safety alert symbol, which means DANGER or WARNING – “personal safety instructions.” Failure to comply with the instructions may result in personal injury or death.**

**Incorrect usage of this machine may result in severe injury. Personnel operating and maintaining it should be trained in the proper use and should read the manuals completely and thoroughly before attempting to set-up, operate, adjust, or service this machine.**

The Quick Reference Decals, located in front of and to the right of the seat, are designed to give the operator/mechanic brief information needed in the daily operation and service of the machine. These decals are not intended to be used in place of this manual but instead is to be used as an extension of this manual. These decals should not be removed or obliterated. Replace these decals if they become unreadable.

It is the **owner's responsibility** to make certain that the operator/mechanic reads and understands this manual and all decals before operating this machine. It is also the **owner's responsibility** to make certain that the operator/mechanic is a qualified and physically able individual, properly trained in the operation of this equipment. Local regulations may restrict the age of the operator/mechanic.

The owner should also ensure that the operator/mechanic knows that they are responsible for their own safety as well as the safety of other persons within the vicinity. **Remember**, the operator/mechanic is responsible for accidents or hazards occurring to other people or their property.

## Safe Maintenance & Adjustment Practices

This product is capable of amputating hands and feet and throwing objects. Always follow all safety instructions to avoid serious injury or death.

Unless specifically required, **DO NOT** have engine running when servicing or making adjustments to tractor. Place control levers in the park brake position, disengage deck clutch, remove ignition switch key and disconnect the negative battery cable. Repairs or maintenance requiring engine power should be performed by trained personnel only. To prevent carbon monoxide poisoning, be sure proper ventilation is available when engine must be operated in an enclosed area.

Follow daily and weekly checklists, making sure hoses are tightly secured and bolts are tightened.

Keep your machine clean and remove any deposits of trash and clippings, which can cause engine fires and hydraulic overheating as well as excessive belt wear. Clean up oil or fuel spillage. Allow machine to cool before storing.

---

**Clean flammable material from machine. Prevent fires by keeping engine compartment, battery, hydraulic lines, fuel line, fuel tank and operator's station clean of accumulated trash, grass clippings, and other debris. Always clean up spilled fuel and oil.**

Always wear adequate ear protection, such as earplugs, when operating this equipment as prolonged exposure to uncomfortable or loud noises can cause impairment or loss of hearing. Do not wear radios or music headphones while operating the machinery. Safe operation requires your full attention.

Never put hands or feet under any part of the machine while it is running.

Except when changing or checking belt, **always** keep belt covers on mower for safety as well as cleanliness.

Stop the engine before removing the grass catcher or unclogging the discharge chute. Never clear the discharge chute with the engine running. Turn off the engine and be sure the blades have stopped before cleaning. Use a stick to clear a plugged discharge area. **Never use your hand!**

Exercise caution when loading or unloading the machine onto a trailer or truck.

Always wear safety goggles or safety glasses with side shields when operating the mower.

Never leave machine unattended with ignition key in switch, especially with children present.

Be alert and turn the machine off if children enter the area.

Always wear adequate eye protection when servicing the battery, hydraulic system, cooling system or when grinding mower blades and removing accumulated debris.

Use extra caution when handling gasoline and other fuels. They are flammable and vapors are explosive.

Never refuel tractor while engine is running; never refuel near an open flame or near devices which can create a spark. Refuel outdoors preferably, or in well ventilated areas.

Never attempt to start engine when there is a strong odor of gasoline fumes present. Locate and correct cause.

Never run the engine in an enclosed area unless exhaust is vented to the outside. Exhaust gases contain carbon monoxide which is odorless and deadly poison.

Never attempt to make any adjustments or repairs to the tractor drive system, mower deck or any attachment while the tractor engine is running or deck clutch is engaged. Repairs or maintenance requiring engine power should be performed by trained personnel only.

Never work under the machine or attachment unless it is safely supported with jack stands. Make certain machine is secure when it is raised and placed on the jack stands. The jack stands should not allow the machine to move when the engine is running and the drive wheels are rotating. **Use only certified jack stands.** Use only appropriate jack stands, with a minimum weight rating of 2000 pounds to block the unit up. Use in pairs only. Follow the instructions supplied with the vehicle stands.

Before working on or under the deck, make certain engine cannot be accidentally started. Shut engine off and remove ignition switch key for maximum safety. Repairs or maintenance requiring engine power should be performed by trained personnel only.

Use a stick or similar instrument to clean under the mower making sure that no part of the body, especially arms and hands are under mower.

Exercise caution when working under the deck as the mower blades are extremely sharp. Wearing gloves or wrapping the blade(s) is advisable when working around or with the blades.

Do not touch hot parts of machine.

Keep nuts and bolts tight, especially the blade attachment bolts. Keep equipment in good condition.

Never tamper with safety devices. Check their proper operation regularly.

Grass collection system components are subject to wear, damage and deterioration, which could expose moving parts or allow objects to be thrown. Frequently check components and replace with manufacturer's recommended parts, when necessary.

Use only genuine Hustler replacement parts to ensure that original standards are maintained.

---

---

## **Using a ramp**

Use extreme caution when loading and unloading a unit with a ramp.

Use only a single, full width ramp; do not use individual ramps for each side of the unit. Having a full width ramp provides a surface for the tractor frame to contact if the unit starts to tip backwards. It also reduces the risk of a wheel going off and the machine tipping over.

Do not exceed a 15 degree angle between the ramp and the ground or between the ramp and the trailer or truck.

When on a ramp avoid sudden acceleration

## **Safety and Instruction Decals**

Specific safety warning decals are located on the equipment near the immediate areas of potential hazards. These decals should not be removed or obliterated. Replace them if they become non-readable.

The following illustrations show the various **safety decals** that are located on the machine. A brief explanation, for those requiring one, is shown to help the operator understand the meanings of these decals.

# Maintenance

## MAINTENANCE LOCATOR CHART

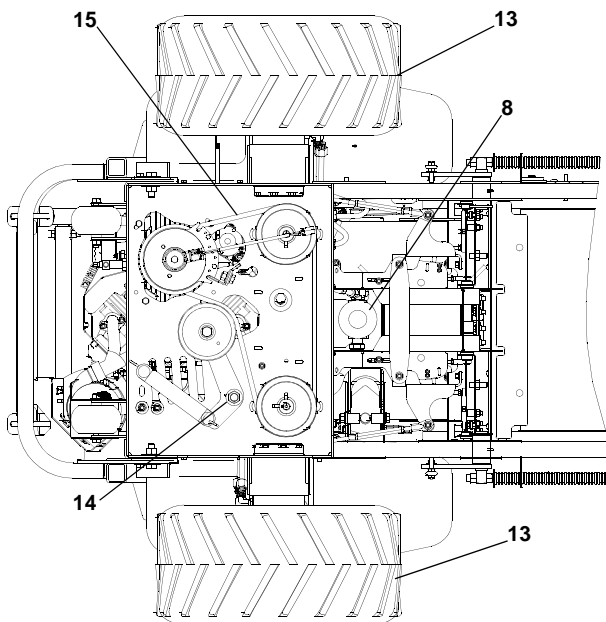
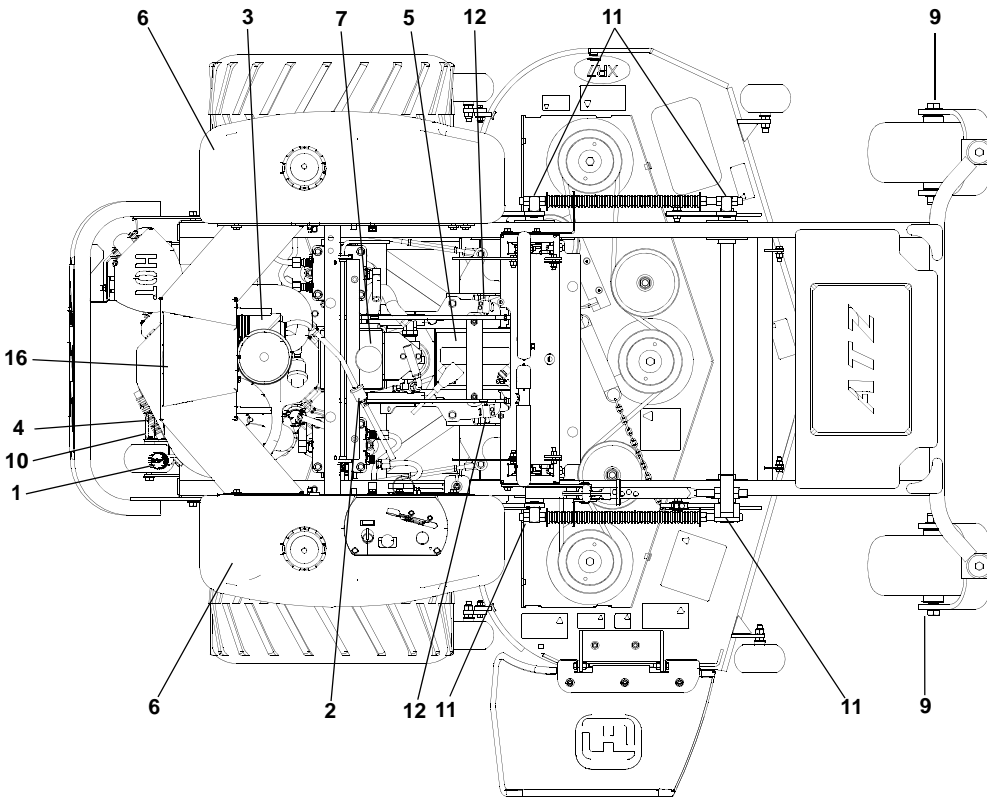

Viewed from bottom of tractor

1. Engine Oil Fill & Dipstick
2. Fuel Filter
3. Engine Air Cleaner
4. Engine Oil Drain Plug
5. Battery
6. Fuel Tanks
7. Hydraulic Oil Reservoir
8. Hydraulic Oil Filter
9. Gauge Wheel Bearing Zerks (2)
10. Engine Oil Filter
11. Deck Height Pivot Zerks (4)
12. Park Brake Switch (2)
13. Drive Tire
14. Pump Idler Zerk (1)
15. Pump Belt
16. Hydraulic Oil Heat Exchanger

FIG. 1



# MAINTENANCE LOCATOR CHART

72" XR-7 deck

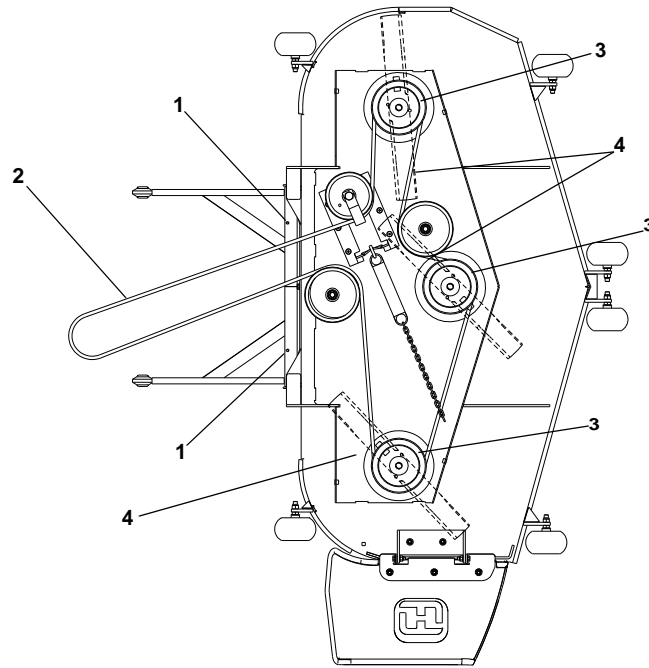

60" XR-7 deck

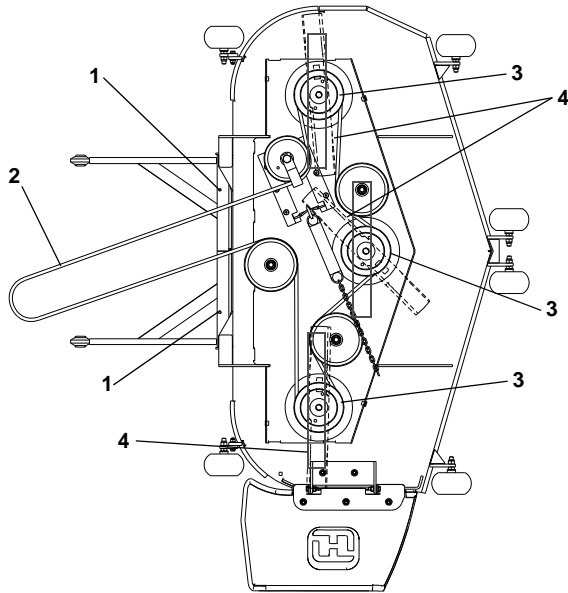

- 1. Deck Pusher Arm Zerks (2)
- 2. Deck Belt
- 3. Spindle Housing Zerk (3)
- 4. Blades

60" Rear Discharge deck

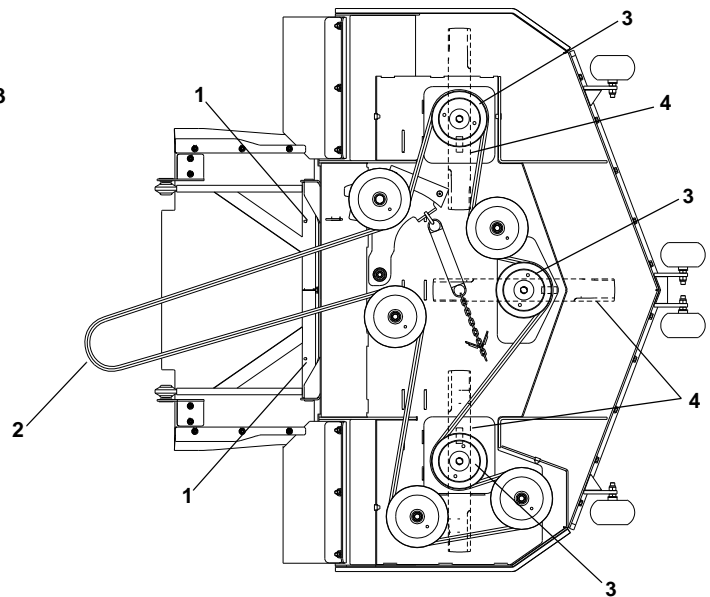

FIG. 2

SERVICE AT INTERVALS INDICATED	WEEKLY OR 50 HOURS	MONTHLY OR 100 HOURS	ANNUALLY OR 500 HOURS
Verify safety start interlock system		Daily	
Visually inspect unit for loose hardware and/or damaged parts		Daily	
Visually inspect tires		Daily	
Check oil level, engine (1)		Daily or every 4 hours	
Clean air intake screen (5)		Daily or every 4 hours	
Clean oil heat exchanger (5)		Daily or every 4 hours	
Check & clean engine compartment		Daily or every 4 hours	
Check air cleaner service indicator		Every 8 hrs.	
Check fuel level		Daily	
Blades - sharpen & securely fastened		Daily	
Discharge chute - securely in place & in lowest position		Daily	
Clean engine and pump compartment		Daily	
Replace air cleaner paper element (5)		As needed	
Grease deck idler	X		
Grease deck pusher arms	X		
Grease pump idler	X		
Grease deck height pivots	X		
Grease gauge wheel bearings	X		
Change engine oil and filter (1) (4)	X		
Clean cylinder and head fins(a)	X		
Check battery connections	X		
Check tire pressure with a gauge	X		
Check hydraulic oil level	X		
Clean engine exterior (a)	X		
Clean & regap spark plugs (a)		X	
Check pump and deck belt tension and condition (6)		X	
Check fuel and hydraulic lines (7)		X	
Check fuel valve and grommet (7)		X	
Tighten lug nuts on wheels (2)		X	
Change fuel filter			X
Clean or replace hydraulic fill cap			X
Change hydraulic oil and filter (3)			X
Grease deck spindle housings			X
Replace spark plugs			X

**NOTES:**

1. Initial oil change is after 5 hours of operation. Thereafter, change oil after every 40 hours operation. Change more often under dusty or dirty conditions and during hot weather periods.
2. Torque initially and after first 2 hours of operation.
3. Perform initial hydraulic filter change after 50 hours (one week) of operation.
4. Change engine oil filter per the engine manufacturer's recommendations. Refer to Engine Owner's Manual for recommendations and other maintenance items.
5. Service more often under dusty or dirty conditions. Use caution when servicing to prevent dust contamination in the engine. **Do not** clean filter element. Replace with a new one.
6. **Pump drive belt only - Inspect every 100 hours** and replace if worn or cracking is noticed. Otherwise, **replace every 400 hours or 2 years** whichever comes first.
7. Check fuel line hoses, fuel valve and grommets for any cracks or leaks
8. Clean more often under dirty or dusty conditions and during hot weather.
9. **Do not** clean filter element. Replace with a new one.

---

## REFERENCES:

a---Refer to Engine Owner's Manual

**NOTE:** After completing maintenance cycle (300 hours), repeat cycle.

## INTRODUCTION

Regular maintenance is the best prevention for costly downtime or expensive, premature repair. The following pages contain suggested maintenance information and schedules which the operator should follow on a routine basis.

Remain alert for unusual noises, they could be signaling a problem. Visually inspect the machine for any abnormal wear or damage. A good time to detect potential problems is while performing scheduled maintenance service. Correcting the problem as quickly as possible is the best insurance.

Clear away heavy build-up of grease, oil and dirt, especially in the engine and hydraulic reservoir areas; minute dust particles are abrasive to close-tolerance engine and hydraulic assemblies.

**Daily inspect** mower for grass clippings and wire and string tangles. The underside of the mower deck will collect a build-up of grass clippings and dirt, especially when grass is wet or has high moisture content. This build-up will harden, restricting blade and air movement and will probably show a poorer quality of cutting. Therefore it should be removed routinely.

To do this it will be necessary to raise and block the deck in the full up position, using jack stands or blocks, and scrape the build-up from underneath.

Some repairs require the assistance of a trained service mechanic and should not be attempted by unskilled personnel. Consult your Hustler service center when assistance is needed.

## TORQUE VALUES



**WARNING:** Particular attention must be given to tightening the drive wheel lug nuts, wheel motor nuts and blade spindle bolts. Failure to correctly torque these items may result in the loss of a wheel or blade, which can cause serious damage or personal injury.

Torque values are given below:

	<b>Ft-lbs.</b>	<b>Nm</b>
Wheel (lug) nuts .....	65-75 .....	88.14-101.7
Wheel motor nut.....	290-310 .....	393.2-420.4
Blade spindle bolt top.....	65-75 .....	88.14-101.7
Blade spindle bolt bottom.....	118.....	160.01

It is recommended that these be checked after the first 2 hours of operation initially, every 50 hours, and following removal for repair or replacement.

For all other torques refer to the various tractor parts manuals for standard torque charts.

**NOTE:** For engine torque values, see engine owner's manual.

## TIRES

It is important for level mowing that the tires have the same amount of air pressure. The recommended pressures are:

Drive wheels..... 8-12 psi (55-69 KPa)  
Gauge wheels ..... semi-pneumatic

The bar tread tires are reversed from what is considered the normal operating position. this allows for better traction when backing up a slope.

---

**Solid fill tires are not recommended** for Hustler turf equipment. On any machine, with solid filled tires, the warranty claim will be denied.



**WARNING:** Explosive separation of a tire and rim can cause serious injury or death.

Do not attempt to mount a tire without the proper equipment and experience to perform the task.

Always maintain the correct tire pressure and never over inflate.

Never weld or heat a wheel and tire assembly as an explosion may occur. Welding can weaken or deform a wheel.

When inflating tires, stand to one side and **not** in front of or over the tire assembly.

Check tires for low pressure, blemishes, damaged rims or missing lug bolts and nuts.

## HOUR METER

To recognize when your machine needs servicing, check the hour meter and the maintenance schedule. The hour meter shows the number of hours the engine has run, and the maintenance schedule lists the service intervals. "FIG. 3".



FIG. 3

## LUBRICATION

1. Grease the front gauge wheel bearings per the Maintenance Schedule. Use SAE multi-purpose grease.
2. Grease the four deck lift pivots, located to the side of the operator's footrest per the Maintenance Schedule. Use SAE multi-purpose grease.
3. Grease the deck idler per the Maintenance Schedule. Use SAE multi-purpose grease.
4. Grease the pump idler per the Maintenance Schedule. Use SAE multi-purpose grease.
5. Grease the two deck pusher arm pivots per the Maintenance Schedule. Use SAE multi-purpose grease.
6. Grease the blade spindle assemblies per the Maintenance Schedule. The spindle assemblies require lubrication annually. Each spindle shaft is equipped with a grease zerk located under the deck. Use no more than one or two ounces of SAE multi-purpose grease, (1 to 2 pumps on an average grease gun). Do not force lubricant into grease zerks. Bearings are sealed and do not require much lubricant.

## ELECTRICAL SYSTEM

The electrical system is a 12-volt, negative ground. Recommended battery size is a garden tractor BCI group U1R with 225 or better cranking AMP rating. A maintenance-free battery is recommended. Otherwise, follow battery manufacturer's maintenance, safety, storing and charging specifications.

---

The battery is located under the seat platform "FIG. 4".

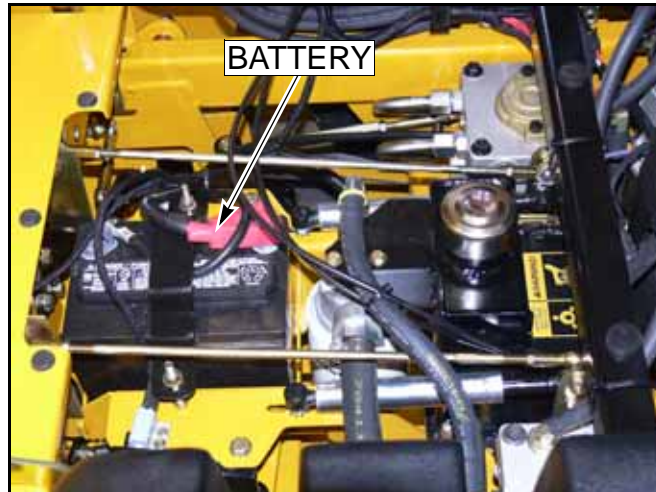

FIG. 4



**WARNING:** Battery posts, terminals, and related accessories contain lead and lead compounds, chemicals known to the State of California to cause cancer and reproductive harm. Wash hands after handling.



**WARNING:** Avoid skin and clothing contact with battery acid.

Always wear eye protection when checking the battery, acid can cause serious injury to skin and eyes. If contact occurs, flush area with clean water and call physician immediately. Acid will also damage clothing.

Do not drink the battery electrolyte.

Do not allow open flame near the battery when charging.

Hydrogen gas forms inside the battery. This gas is both toxic and flammable and may cause an explosion if exposed to flame.

Always remove the negative ground first and replace it last.

Do not overfill battery.

Electrolyte may overflow and damage paint, wiring or structure. When cleaning the battery, use soap and water. Be careful not to get soap and water into the battery. Clean the battery terminals with a solution of four parts water and one part baking soda when they become corroded.



**WARNING:** Shorts caused by battery terminals or metal tools touching metal tractor components can cause sparks. Sparks can cause a battery gas explosion which will result in personal injury.

Prevent the battery terminals from touching any metal tractor parts when removing or installing the battery.

Do not allow metal tools to short between the battery terminals and metal tractor parts.



**WARNING:** Incorrect battery cable routing could cause damage to the tractor and battery cables. This can cause sparks which can cause a battery gas explosion which will result in personal injury.

Always **disconnect** the negative (black) battery cable before disconnecting the positive (red) cable.

Always **connect** the positive (red) battery cable before connecting the negative (black) cable.

Common circuit failures are usually caused by shorting, corroded or dirty terminals; loose connections, defective wire insulation or broken wires. Switches, solenoids and ignition components may also fail, causing a shorted or open circuit.

---

Before attempting any failure diagnosis of the electrical system, use a test light or voltmeter to check the battery voltage. If the battery voltage is satisfactory, check the cleanliness and tightness of the terminals and ground connections. A general understanding of electrical servicing and use of basic test equipment is necessary for troubleshooting and repair.

Major overhaul or repair of the starting motor or charging system should be performed by trained technicians only.

## ACCESS TO ENGINE AND HYDRAULIC PUMPS

The hydraulic pumps are accessed by lifting the seat platform. The seat platform is hinged at the front. To raise it, release seat latch and tilt seat platform up and forward. The seat platform catch ("FIG. 5") will prevent the seat from going all the way over. However, if more access is desired under the seat platform, the seat platform catch can be raised allowing the seat to pivot more. **Make certain to place the control arms in the park brake position and pivot the arm rests upward before placing the seat platform in the full forward position to prevent arm rest damage.**

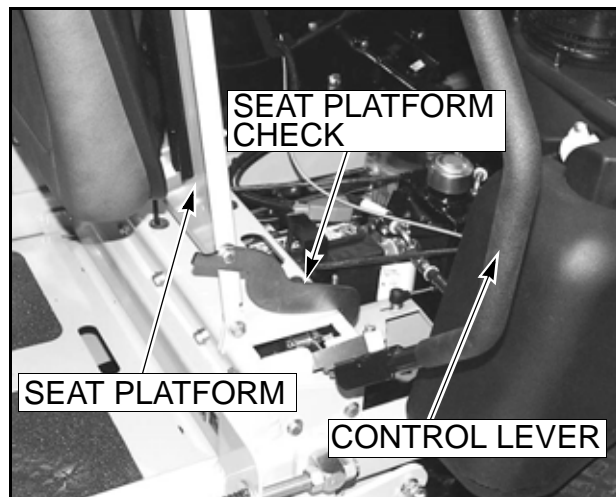

FIG. 5



**WARNING:** Always wear adequate eye protection when servicing the hydraulic system and battery.

## HYDRAULIC SYSTEM

**IMPORTANT:** Never use hydraulic or automatic transmission fluid in this system; use only motor oil as specified. Remember, dirt is the primary enemy of any hydraulic system.



**WARNING:** Hydraulic oil escaping under pressure can penetrate skin. Hydraulic oil may cause infection in a minor cut or opening in the skin. If exposed to hydraulic fluid, see a doctor at once.

Before applying pressure to hydraulic system, make sure all connections are tight and all hoses and lines are in good condition. To find a leak under pressure, use a piece of cardboard or wood — **never** use your hands. Relieve all pressure in the system before disconnecting or working on hydraulic lines. To relieve pressure, lower all attachments and shut off engine.

The 1.0 U.S. gallon (3.79 liter) hydraulic reservoir is located in front of the engine and under the operator's platform "FIG. 6".

Check oil level in hydraulic system after every 50 hours of operation or weekly, whichever occurs first. Check more often if system appears to be leaking or otherwise malfunctioning.

Fluid level should be 1" from top of reservoir. Use only SAE 10W40 SG, SF/CC, CD service motor oil.

Change hydraulic system filter element ("FIG. 6") after first 50 hours of tractor operation, then replace filter and oil in reservoir every 500 hours thereafter. When changing hydraulic oil use 1/2 unit (approximately 3.5 oz.) of Lubrizol additive (Hustler P/N 027912). This additive, available from your Hustler dealer, will increase the performance life of the hydraulic system components.

The system filter is located directly in front of the hydraulic reservoir. A standard oil filter wrench is used to change filter, threads are right handed. **Use a Hustler approved filter element only.**

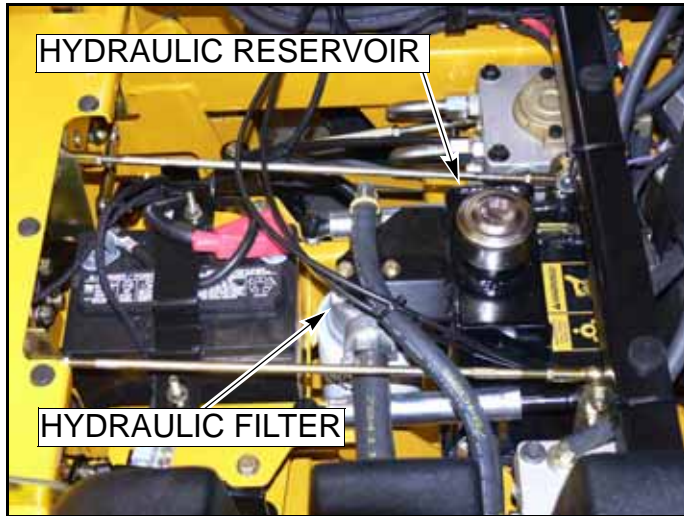

FIG. 6

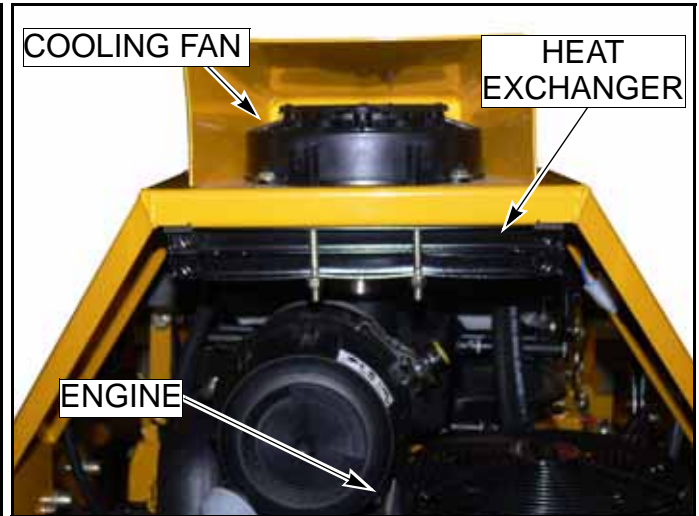

FIG. 7

**IMPORTANT:** Prefill the filter element with clean oil, before installing, to prevent drawing air into the system pump.

1. Fill the filter element with clean system oil. Smear a light coating of oil on upper surface of rubber seal.
2. Install the filter element on base. Tighten the oil filter by hand until the filter seal makes contact with the filter head, then tighten an additional 3/4 - 1 turn with an oil filter wrench. — DO NOT OVERTIGHTEN.
3. Start tractor engine and let run at approximately 2/3 throttle for a few minutes to work any trapped air out of the system before engaging the steering control lever.
4. Stop the engine and check the filter and connections for leaks.
5. Check the hydraulic reservoir for specified oil level. Add clean oil as necessary.

Clean or replace hydraulic reservoir cap annually. Cap may be cleaned by dipping in or flushing with cleaning solvent. Follow manufacturer's instructions and warnings for application of solvent type selected.

A hydraulic oil heat exchanger is installed on the Super Z. This heat exchanger is designed to keep hydraulic system oil temperature lower in hot operating conditions or heavy continuous operating conditions.

This hydraulic heat exchanger is located above the engine. Air is drawn across the cooling fins by an electric fan located above the heat exchanger "FIG. 7".

Never force anything into the heat exchanger fins which may bend or distort them. For cleaning, use compressed air or pressurized water only.

## FUEL SYSTEM



**DANGER:** Observe usual fuel handling precautions:

Do not smoke while refueling.

Do not fill tank with engine running or while engine is hot. Clean up any gasoline spills.

Allow engine to cool before storing machine inside a building.

Keep fuel away from open flame or spark and store machine away from open flame or spark if there is fuel in the tank.

Use extra caution when handling gasoline and other fuels. They are flammable and vapors are explosive. A fire or explosion from gasoline can burn you and others and can damage property.

Refuel outdoors preferably, or in well ventilated areas.

Never attempt to start engine when there is a strong odor of gasoline fumes present. Locate and correct cause.

Store gasoline in an approved container and keep it out of the reach of children. Never buy more than a 30 day supply of gasoline.

Always place gasoline containers on the ground away from your vehicle before filling.

Do not fill gasoline containers inside a vehicle or on a truck or trailer as interior carpets or plastic truck bed liners may insulate the container and slow the loss of any static charge.

When practical, remove equipment from the truck or trailer and refuel the equipment with its wheels on the ground. If this is not possible, then refuel the equipment on the truck or trailer using a portable container and not a gasoline dispenser nozzle. If a gasoline dispenser nozzle must be used, keep the nozzle in contact with the rim of the fuel tank or container opening at all times until fueling is complete.



**WARNING:** Gasoline is harmful or fatal if swallowed.

Long-term exposure to vapors can cause serious injury and illness.

Avoid prolonged breathing of vapors.

Keep face away from nozzle and gas tank or conditioner opening.

Keep gas away from eyes and skin.



FIG. 8



FIG. 9



---

The fuel tanks are located in the tractor's fenders. ("FIG. 8") Total capacity for the fuel tanks is 15 U.S. gallon (56.8 liter)

Use regular unleaded gasoline with an octane rating of 87 or higher.

The fuel filter ("FIG. 9") is installed in the fuel line between fuel tanks and engine fuel pump. Replace filter annually or after every 500 hours of operation, whichever occurs first.

When replacing the fuel filter, check the fuel line hoses and fuel shut-off valve grommet for any cracks or leaks. Replace as needed.

Hustler ATZ tractors are equipped with a fuel shutoff valve located on the right fuel tank mount ("FIG. 10"). Rotate the valve to the middle position (shown) to prevent fuel flow to the fuel pump. The forward position allows fuel to flow from the right fuel tank to the fuel pump. The rear position allows fuel to flow from the left fuel tank to the fuel pump. Close this valve to prevent fuel flow to the engine when servicing the fuel system or when transporting the unit on a trailer or truck.

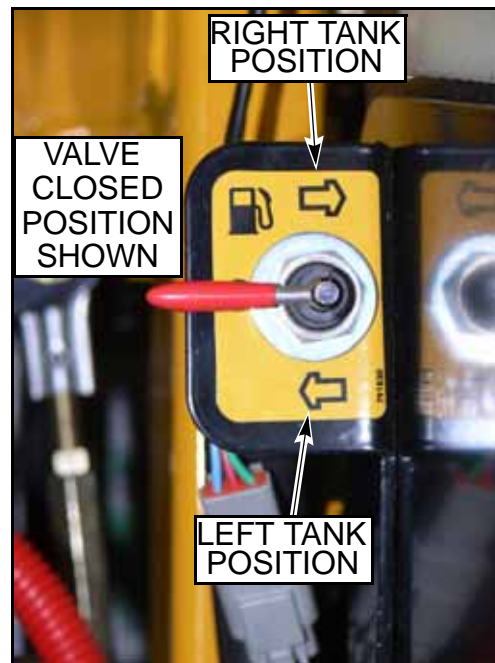

FIG. 10

## ENGINE OIL AND FILTER

Check engine oil daily and after every 4 hours of operation. Crankcase dipstick and oil filler tube are located at the rear of the machine ("FIG. 11"). Tractor must be sitting level when checking oil. Refer to engine manual and maintenance schedule for oil recommendation and capacities.

Change the engine oil and filter after the first 5 hours of operation, per the engine manufacturer's recommendations after that. If tractor is being operated in extremely dirty conditions, then it is recommended oil be changed more frequently.

---

The oil drain and oil filter are located at the rear of the engine "FIG. 11".

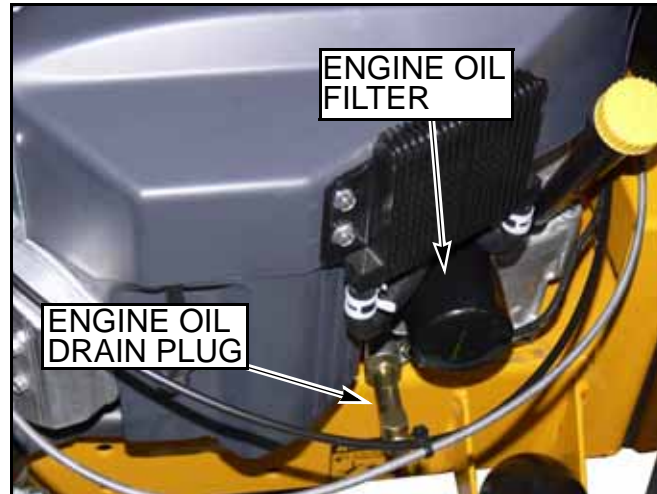

FIG. 11

## ENGINE AIR FILTER

Perform engine air filter maintenance per the scheduled maintenance chart. See "SERVICE AT INTERVALS INDICATED" on page 12-8.

A specially designed dry filter is standard equipment on the Hustler ATZ tractors and supplies clean combustion air to the engine "FIG. 12".



FIG. 12

## RECOMMENDED SERVICE PROCEDURE

Many engine failures can be attributed to improper air cleaner servicing. Ingested dust and dirt will cause cylinder, piston and bearing damage in a few hours. "Dusted" engines will result from:

1. Overservicing the air filter element.
2. Improper installation.
3. Damaged filter, seals or canister.
4. Incorrect air filter element size.
5. Use of poorly designed aftermarket air filter elements.

---

Air cleaner servicing is an inexpensive maintenance check that can prevent costly non-warrantable premature engine damage.

## OVERSERVICING

Overservicing occurs when an air filter element is removed for cleaning or replacement before it is necessary. Each time the filter is removed a small amount of dirt and dust could fall in the intake system. This accumulated dirt can cause a dusted engine. It only takes a few grams of ingested dirt over the normal service life of an engine to cause a dusted engine.

**Do not clean element, replace with a new element only.** Cleaning used air filter elements, through improper cleaning procedures, can get dust on the inside of the filter causing dirt ingestion and engine failure.

It is important to note that whenever an air filter element is cleaned by **any method**, the person or company performing the cleaning assumes responsibility for the integrity of the filter from then on. **The Donaldson warranty for air filters expires upon cleaning or servicing in any manner because the condition of the filter after servicing is completely out of their control. Therefore, on a dust ingested engine failure, there will be no warranty consideration if the air filter element has been cleaned or serviced in any manner.**

A partially dirty air filter element works better than a new element. Therefore, a dirty filter element is not bad for the engine unless it is excessively restricting the air flow and engine performance is affected. The reason is simple. The media in the filter must be porous to allow air to pass through it. When dirty air passes through the filter, the dirt plugs some of the holes in the media and actually acts as part of the filter media. When the next round of dirt enters, the first dirt helps filter out even smaller particles making the filter more efficient at stopping dirt from entering the engine. This is referred to as barrier filtration.

Of course, at some point the filter media becomes too clogged to allow air to pass.

The mowing conditions will determine the frequency of air filter element changing.

## IMPROPER INSTALLATION OF AN AIR FILTER ELEMENT

Dust must not leak past the seals on each end of the air filter element. The filter must be aligned within the canister and properly seated for an effective seal so that no dirt can enter the engine.

## DAMAGED FILTER, SEALS OR CANISTER

Never bang or bump the filter element against the tire or any solid object, as dust and dirt particles will be forced through the media causing continual passing of dirt into the engine. Visually inspect the outside of the air cleaner canister periodically for external damage and replace if necessary.

## INCORRECT AIR CLEANER ELEMENT

Use only the correct Donaldson air filter element, Hustler part number 785261, which is designed to fit the canister properly.

Hustler air filter elements have the correct media composition, filter area, micron size and dimensions. Always use genuine Hustler filters. Many aftermarket filters have been found to be incompatible with Hustler's canisters and engines.

The air filter must remain intact to block passage of dirt and foreign particles from entering the engine. Being inclined to disbelieve the need for more expensive air filter elements used on gasoline engines may cause some individuals to opt for a less expensive part.

The filter element must be sufficient size and construction to withstand stresses, caused by rapid cycling of the air volume demanded by the engine, without cracking or tearing under fatigue and pressure (especially diesel engines). Therefore, Hustler Turf Equipment and the engine manufacturers have carefully selected a reliable filter designed to fit the needs of the engines. The filter specified is a Donaldson filter, Hustler part number 785261.

---

Owners should be reminded that failure to use original equipment replacement parts is an "alteration" and will not be considered for warranty in the event of engine damage.

## RECOMMENDED SERVICE PROCEDURE

1. Release clamps and remove element. Clean the canister with a damp cloth.
2. Before installing a new element, inspect it by placing a bright light inside and rotate the element slowly, looking for any holes or tears in the paper. Also check gaskets for cuts or tears. Do not attempt to use a damaged element which will allow abrasive particles to enter the engine.
3. Reinstall the dust cup. Make sure it seals all the way around the air cleaner body, then tighten the clamps.
4. Check all fittings and clamps periodically for tightness and inspect hoses for holes or cracks.
5. Periodically check the intake hose for signs of ingested dust. Locate and repair the source of ingested dirt.
6. Never operate a machine without an air filter installed.

## AIR RESTRICTION INDICATOR

Any unit with a Kohler or Kawasaki engine will have an air restriction indicator installed in the air cleaner "FIG. 13".

Replace the element whenever the restriction indicator shows reaches the change filter red line. Check the indicator daily and replace element as needed or annually whichever occurs first.

Reset the indicator by pushing in on the yellow button after each element change "FIG. 13"

A restriction indicator takes the guesswork out of air cleaner servicing and allows you to safely benefit from the filter's optimum performance.

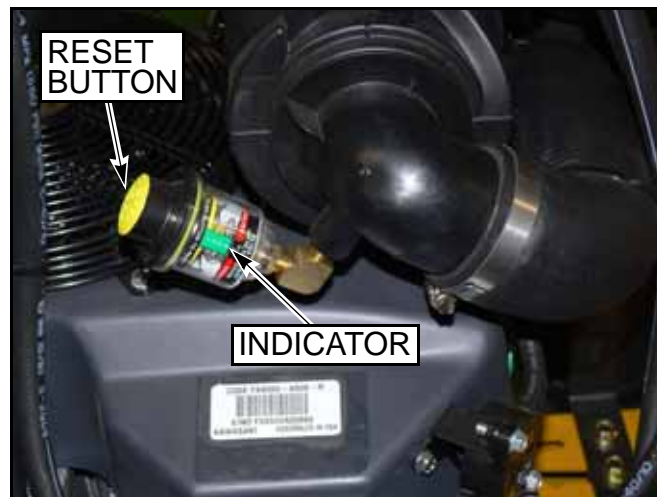

FIG. 13

## GENERAL ENGINE MAINTENANCE

Detailed instructions and recommendations for break-in and regular maintenance are specified in the Engine Owner's manual. Please refer to this manual for engine servicing, lubricating oil levels with quality and viscosity recommendations, bolt torques, etc. The engine warranty is backed by the manufacturer. Special attention should be paid to applicable data which will not be duplicated here.

## BELT REPLACEMENT

"FIG. 14", "FIG. 15", "FIG. 16" & "FIG. 17" show diagrams and descriptions of the unit's belt drive systems.

Inspect these belts frequently for wear and serviceability. Replace a belt that shows signs of severe cuts, tears, separation, weather checking and cracking, or burns caused by slipping. Slight raveling of belt covering does not indicate failure, trim ravelings with a sharp knife.

**NOTE:** Replace the belt every 400 hours or every two (2) years whichever comes first.

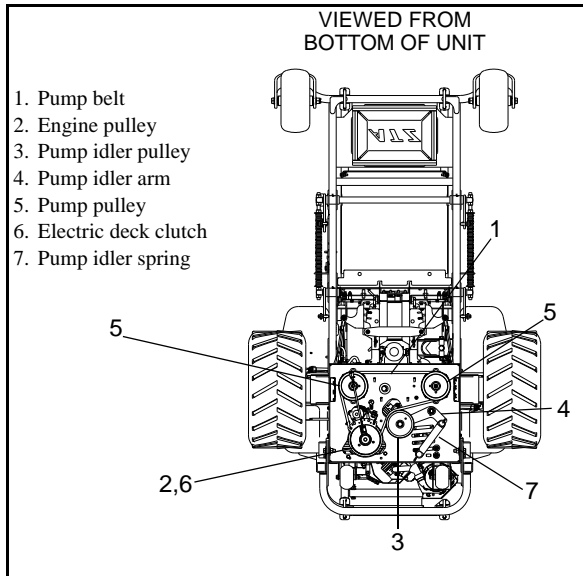

FIG. 14

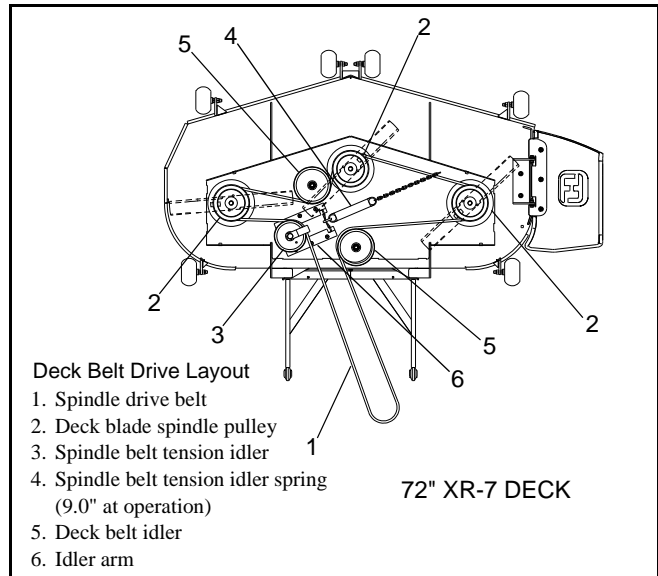

FIG. 15

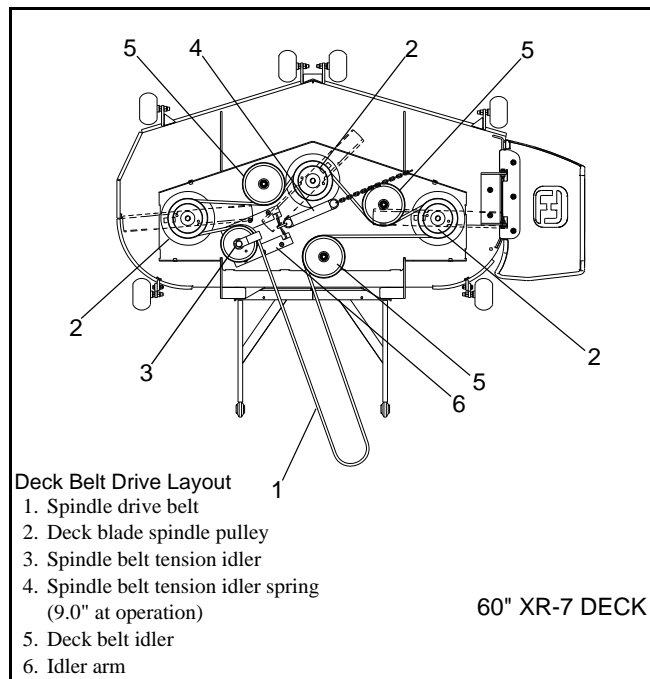

FIG. 16

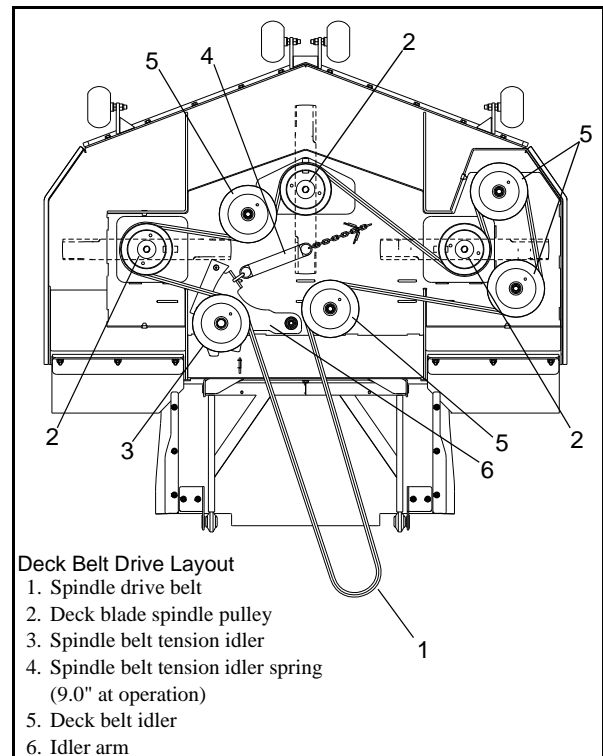

FIG. 17



**WARNING:** If the pump belt fails, loss of control will occur especially when operating on a slope. **If you lose steering control while operating the machine, place the steering control levers in the park brake position immediately. Inspect the machine and involve your Hustler dealer to resolve the problem before continuing to operate.**

Inspect the belt pulley grooves and flanges for wear. A new belt, or one in good condition, should never

---

run against the bottom of the groove. Replace the pulley when this is the case, otherwise belt will lose power and slip excessively.

Never pry a belt to get it on a pulley as this will cut or damage the fibers of the belt covering.

Keep oil and grease away from belts, and never use belt dressings. Any of these will destroy the belt composition in a very short time.

## MOWER BLADE MAINTENANCE

Check the mower blades daily, they are the key to power efficiency and well groomed turf. Keep them sharp, a dull blade will tear rather than cut the grass, leaving a brown ragged top on the grass within a few hours. A dull blade also requires more power from the engine.

Replace any blade which is bent, cracked or broken.



**WARNING:** Never attempt to straighten a bent blade by heating, or weld a cracked or broken blade as the blade may break and cause serious injury.



**DANGER:** Never work with blades while engine is running or deck clutch switch is engaged (on). Always place deck clutch switch in the **disengaged** position, place control levers in the park brake position and turn engine off and disconnect negative battery cable. Block up mower when you **must** work under it. Wear gloves when handling blades. **Always check for blade damage** if mower strikes rock, branch or other foreign object during mowing!



**WARNING:** Always wear adequate eye protection when grinding mower blades.

## MOWER BLADE REMOVAL

Use a 15/16" wrench to remove the 5/8" cap screw holding the blade to the spindle shaft from underneath.

Sharpen the blades on a grinder following pattern as shown "FIG. 18". Touch-up sharpening can be done with a file.

Check the blades for balance following grinding. A commercial balancing tool is available through most hardware supply stores, or balancing can be done by placing the blade on an inverted line punch or 1/2" bolt. Blade should not lean or tilt. Spin the blade slowly, blade should not wobble. If blade is out of balance, true it up before reinstalling.

Lay the blade on a flat surface and check for distortion "FIG. 19" and "FIG. 20". Replace any distorted blade.

Do not re-use spindle bolts which have stripped, worn or undercut threads. Torque bolts to 118 foot-pounds when reinstalling blades.



**WARNING:** When mounting blades, rotate them after installation to ensure blade tips do not touch each other or sides of the mower.



**WARNING:** Failure to correctly torque the bolt may result in the loss of the blade which can cause serious injury.



**WARNING:** Mower blades are sharp and can cut. Wrap the blade(s) or wear gloves and use extra caution when servicing them.

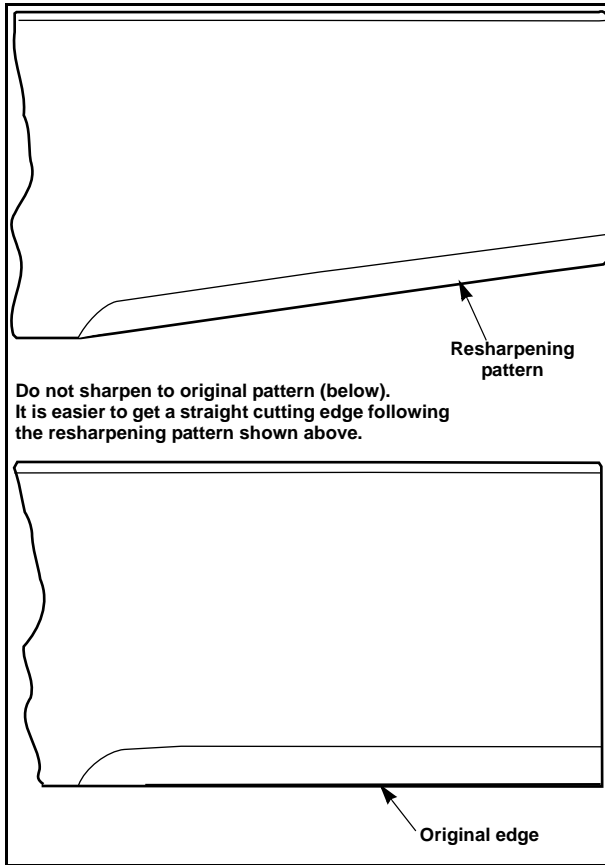

FIG. 18

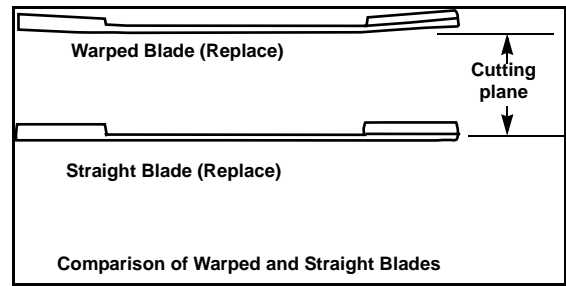

FIG. 19

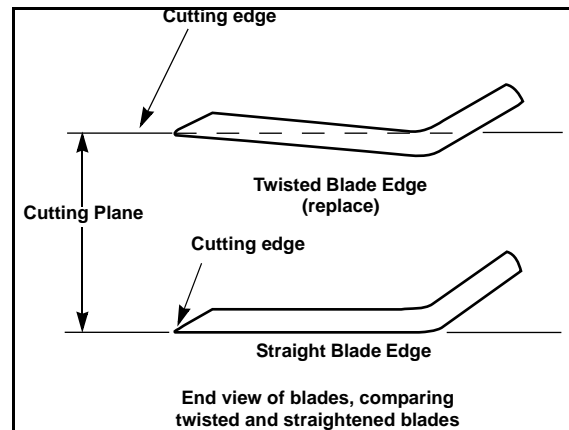

FIG. 20

---

# Adjustment

## INTRODUCTION

Your Hustler ATZ was adjusted before it left the factory and was checked during predelivery setup. However, after start-up and continued use, a certain amount of break-in wear will cause some adjustments to change.

Remain alert for unusual noises, they could be signaling a problem. Visually inspect the machine for any abnormal wear or damage. A good time to detect potential problems is while performing scheduled maintenance service. Correcting the problem as quickly as possible is the best insurance.

Clear away heavy build-up of grease, oil and dirt, especially in the area of reservoir and oil and engine combustion air; minute dust particle are abrasive to close-tolerance engine and hydraulic assemblies.

Some repairs require the assistance of a trained service mechanic and should not be attempted by unskilled personnel. Consult your Hustler service center when assistance is needed.

## STEERING LINKAGE

The neutral adjustment for the control levers in the neutral position is discussed in this section.

The tractor steering has been factory adjusted to eliminate creeping when the control levers are in the neutral position "FIG. 21". However, should the tractor begin to creep, the control lever linkage can be adjusted as follows:

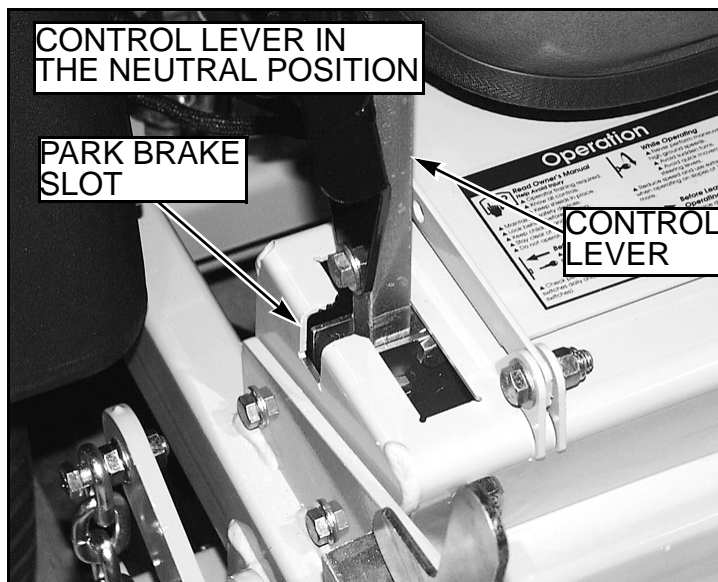

FIG. 21

## CONTROL LEVER NEUTRAL ADJUSTMENT

Before considering any adjustment, check the tire air pressure and make certain hydraulic system oil is at operating temperature. Unequal tire pressure will cause the tractor to drift to one side. Refer to tire pressure information in the Maintenance section of this manual.

Fine adjustment to the unit's steering is made with the adjustable pump linkage rods located between the control lever and pump arms "FIG. 22".

Neutral is properly adjusted when the control levers are in the neutral position and the drive wheels are not turning.



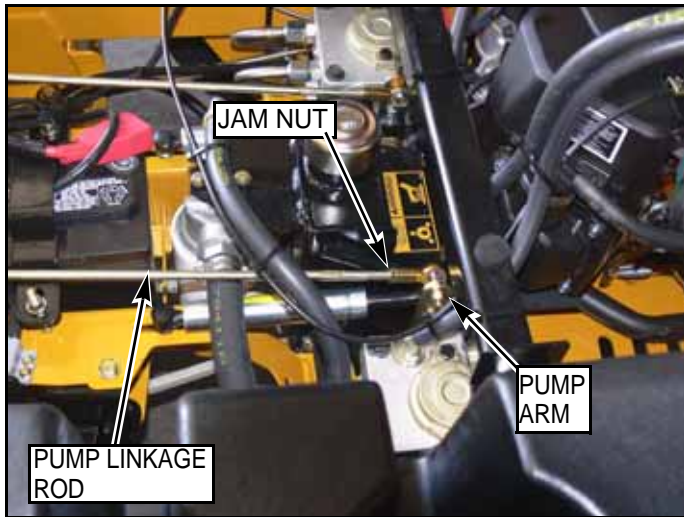

FIG. 22

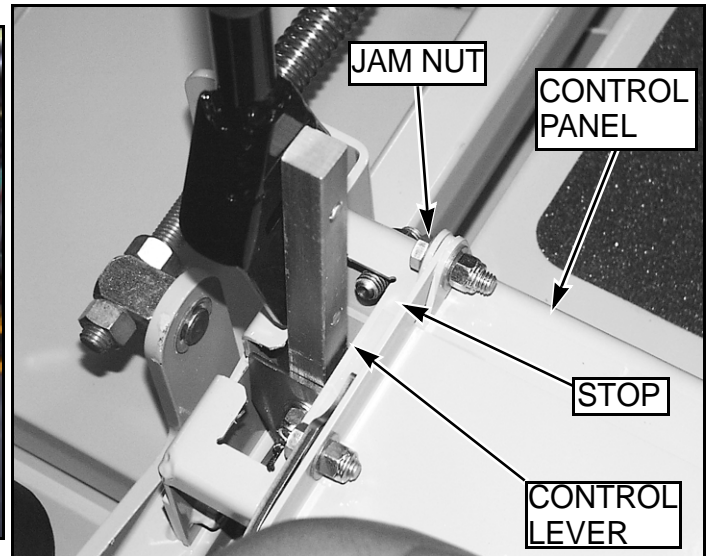

FIG. 23

If the tractor creeps in the neutral position the control linkage may be adjusted as follows:



1. Raise and block the tractor up so the drive wheels are off of the floor.
 

**WARNING:** Never work under the machine or attachment unless it is safely supported with jack stands. Make certain machine is secure when it is raised and placed on the jack stands. The jack stands should not allow the machine to move when the engine is running and the drive wheels are rotating. **Use only certified jack stands.** Use only appropriate jack stands, with a minimum weight rating of 2000 pounds to block the unit up. Use in pairs only. Follow the instructions supplied with the vehicle stands.
2. Position the control lever in the neutral position. Disengage the deck clutch.
3. Start the engine and observe which way the wheels are rotating.
4. If wheel(s) are rotating forward, loosen the jam nuts on the pump linkage rods and rotate the rod to lengthen the steering control linkage until the wheel(s) come to a stop "FIG. 22". Repeat for the opposite side if necessary.
 

**NOTE: The left linkage controls the left hydraulic pump and the right linkage controls the right hydraulic pump.**
5. If wheel(s) are rotating in reverse then loosen the jam nuts on the pump linkage rods and rotate the rod to shorten the steering control linkage until the wheel(s) come to a stop "FIG. 22". Repeat for the opposite side if necessary.
 

**NOTE: The left linkage controls the left hydraulic pump and the right linkage controls the right hydraulic pump.**
6. When both wheels remain in neutral, tighten the jam nuts to lock the turnbuckle in place.
7. Test again by moving the control levers forward and backward before returning them to the neutral position. If the tires are in neutral, the unit is now ready for operation.
8. After adjusting for neutral it may be necessary to re-adjust the control lever stop "FIG. 23".

## CONTROL LEVER STOPS

The control lever stops "FIG. 23" are designed to do two things: First, and most important, they must keep the pumps from bottoming out internally. Secondly, the stops may be adjusted to help drive straight when the control levers are pushed forward against the stops.

To keep the pumps from bottoming out internally use the following procedure:

1. To make the first adjustment the tractor engine must NOT be running.
2. Check to make sure the control levers are against the stops before the pumps are bottomed out internally. To do this, gently and slowly move the control levers forward and feel if there is some resistance on the pump lever before the control levers hit the stops. Check one side at a time. If you sense that the pump arms are stopping the forward motion of the control arms, loosen the jam nut on the adjustable stop of the

---

corresponding side and turn the stop (set screw) inward to stop the control levers slightly before the pump bottoms out. Lock in place when the adjustment is correct by re-tightening the jam nut.

3. Do this for each side.

To adjust the stops for driving straight when control levers are against the stops during operation:

1. Determine which drive tire is rotating too fast when both control levers are against the stops. Then stop the tractor and loosen the lock nut on the side which is rotating too fast and turn the stop (set screw) inward to stop the control lever sooner. Tighten the lock nut on the stop and test again. Repeat this procedure until unit drives straight.

**NOTE:** Since this is a hydrostatic drive, variables such as temperature of oil, efficiency of pumps and motors, tire pressure etc. may effect the consistency of the ability to rely on the stops to drive straight without the operator making minor steering adjustments with the control arms.

## STEERING DAMPENER

The steering dampener, "FIG. 24", is spring loaded to return the control levers to the neutral position from the reverse position. This gives the operator a sense of neutral during operation.

To set the steering dampeners in the correct operating position follow these steps:

1. Place the control lever in the neutral position.
2. Loosen the steering dampener's front ball stud.
3. Pull the dampener spring housing pass the point that the internal spring is engaged.
4. Release the dampener spring housing and allow the internal spring to bring the housing back to the neutral position.
5. Tighten the nut on the steering dampener's front ball stud.

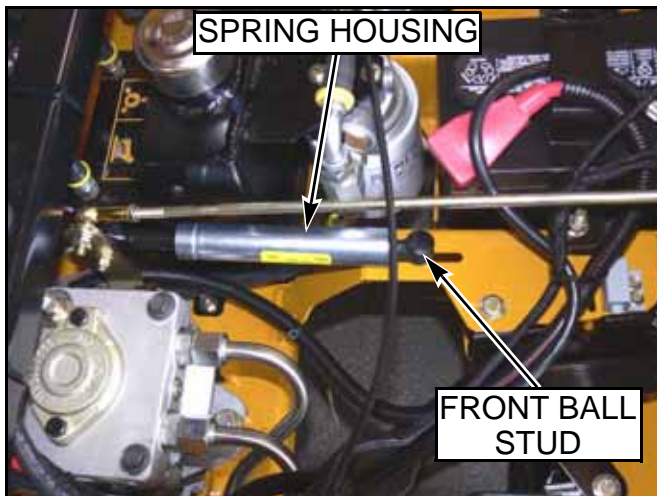

FIG. 24

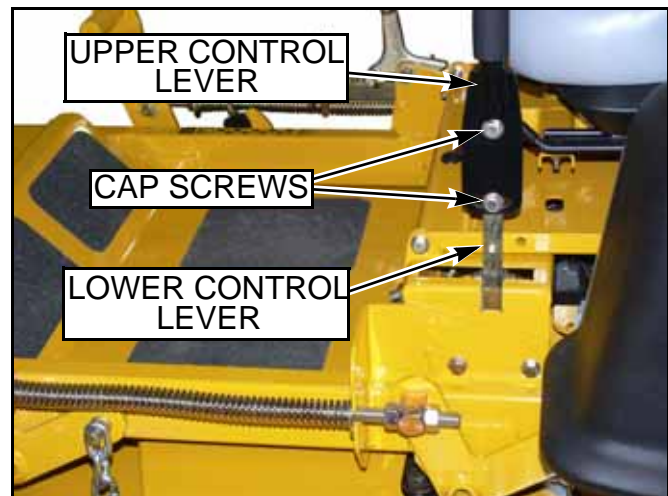

FIG. 25

## CONTROL LEVER ADJUSTMENT

The control levers can be adjusted for operator comfort. By loosening the cap screws that attaches the upper control lever to the lower lever "FIG. 25", the upper control lever can be pivoted to fit the operator's personal preference.

The control levers should be adjusted so that they align with each other when in the neutral position.

## PARK BRAKE ADJUSTMENT

Occasionally check the park brakes and adjustment using the following method:

1. Position the control levers in the neutral position. Disengage the deck clutch.



**WARNING:** Never work under the machine or attachment unless it is safely supported with jack stands. Make certain machine is secure when it is raised and placed on the jack stands. The jack stands should not allow the machine to move when the engine is running and the drive wheels are rotating. **Use only certified jack stands.** Use only appropriate jack stands, with a minimum weight rating of 2000 pounds to block the unit up. Use in pairs only. Follow the instructions supplied with the vehicle stands.

**NOTE:** The front brake link is not adjustable. "FIG. 26"

2. Raise and block the tractor up so the drive wheels are off of the floor.
3. Open the hydraulic pump's bypass valve "FIG. 27", on the side that is being adjusted, by turning bypass valves counter clockwise one-half to one revolution. The valve stems on each hydraulic pump are located near the top and are identified as a hex stud.

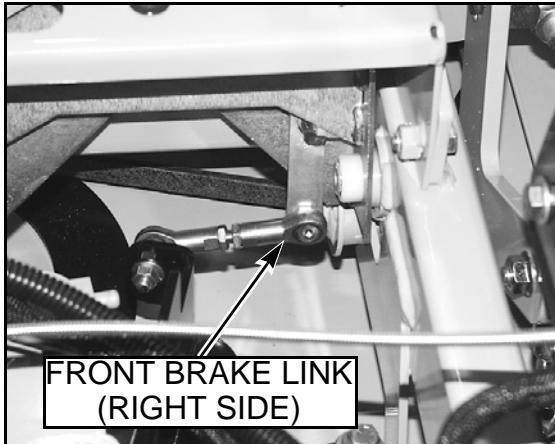

FIG. 26

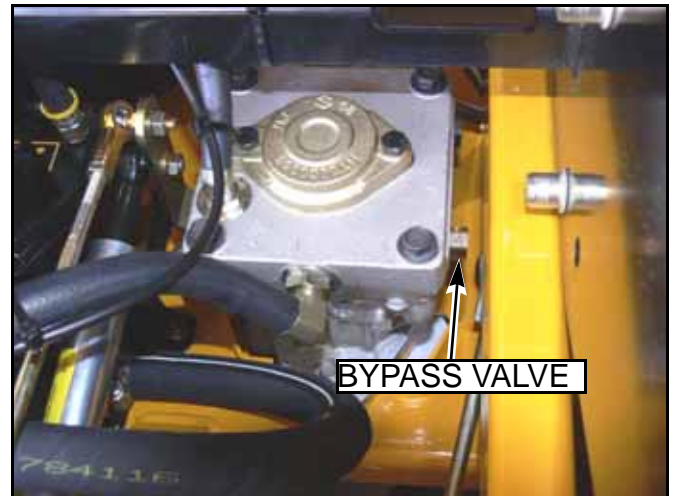

FIG. 27

4. Rotate the tire. The tire should rotate. Remember hydraulic oil resistance will prevent the tire from rotating freely even with the bypass valves open. There should be no resistance from the brakes at this point.
5. Move the control lever to where it is just inside (1/8") the park brake slot "FIG. 28".  
**NOTE:** When the control lever is against the outside edge of the the slot, the brakes should not be engaged.
6. Rotate the tire. If the brake is adjusted properly the tire will still rotate but friction will start to become noticeable here. However, if no brake resistance is noticed, the brake needs adjusted as follows:
7. Loosen the brake linkage jam nuts "FIG. 29".

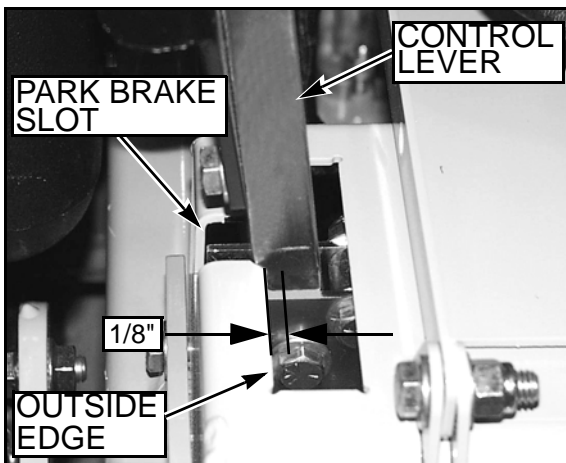

FIG. 28

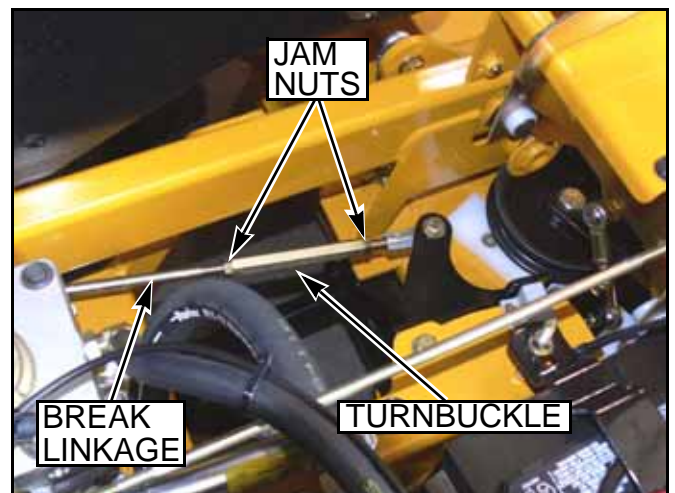

FIG. 29

8. Rotate the tire and at the same time rotate the turnbuckle to shorten the length of the brake linkage to increase the brake pressure. When you feel the brake begin to engage, stop adjusting the turnbuckle. Re-tighten the jam nuts on the turnbuckle.
9. Place the control lever in the park brake slot "FIG. 28". The tire should not rotate when the control lever is in the park brake position.
10. Place the control lever in the neutral position. The tire should rotate freely.
11. Close the hydraulic pump's bypass valve.
12. Repeat steps 3 thru 11 for the other side.
13. Remove the jack stands and lower the unit. It is now ready to operate.

## HYDRAULIC PUMP BELT ADJUSTMENT

The pump drive belt tension remains constant by means of a tension idler and spring "FIG. 30". There is no tension adjustment of this belt.

**NOTE:** Replace the belt every 400 hours or every two (2) years whichever comes first.



**WARNING:** If the pump belt fails, loss of control will occur especially when operating on a slope. If you lose steering control while operating the machine, place the steering control levers in the park brake position immediately. Inspect the machine and involve your Hustler dealer to resolve the problem before continuing to operate.

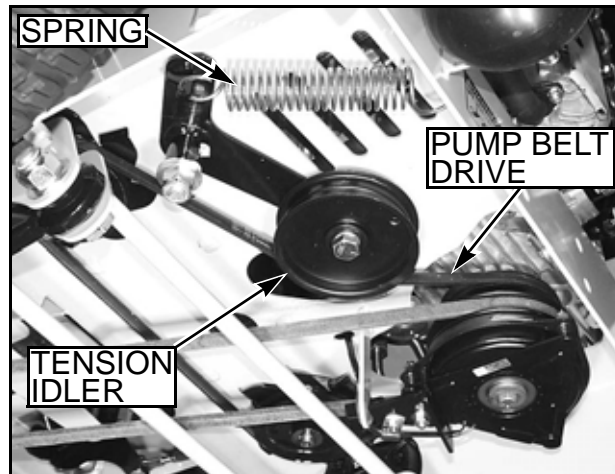

FIG. 30

## DECK DRIVE BELT ADJUSTMENT

The spindle belt tension remains constant by means of a tension idler and spring "FIG. 31". The spring tension should be such that the belt does not slip under normal operating load conditions, assuming the belt is not excessively worn or damaged. As belt stretches and wears in, adjustment may become necessary. To increase belt tension, move the spring chain one (or more) link(s) at the anchor bracket "FIG. 31". Installed spring length should be 9.0"  $\pm$  .3" (22.8 cm  $\pm$  .76 cm) originally with adjustments of .60" (15.2mm) per chain link "FIG. 32".

**IMPORTANT:** Do not over tension the spring to compensate for a badly worn belt or pulley.



FIG. 31

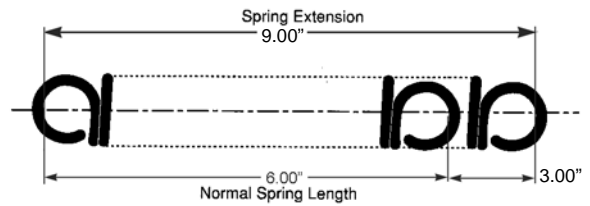

FIG. 32

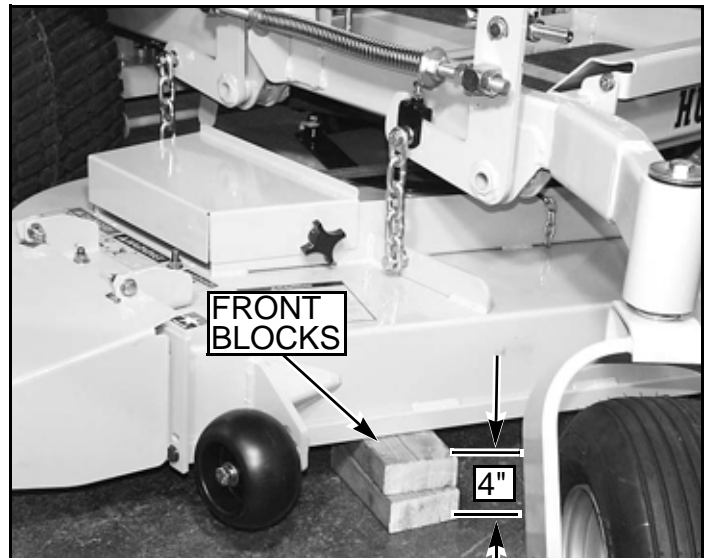

FIG. 33

## ENGINE RPM SETTING

The Hustler ATZ is designed so that the engine will run at 3600 rpm static pump load only. At this speed the hydraulic pumps are running at their maximum rated speed.

## DECK LEVELING AND HEIGHT ADJUSTMENT

The mower deck has three areas that may need to be checked and adjusted periodically. Before considering any mower deck leveling adjustments, check that the tire air pressure is within the specified range.

### DECK LEVEL ADJUSTMENTS

Leveling the deck must be done in the following manner and order:

1. Check tire pressures to make certain they are properly inflated before starting to level deck. The recommended pressures are as follows:
  - Drive wheels tire pressure..... 8 - 12 psi
  - Gauge wheels tire pressure ..... 8 - 12 psi



**WARNING:** Stop engine. Make sure deck clutch switch is **in the down (OFF) position**. Place control levers in the brake position before leaving machine.

2. Park the unit on a flat surface.

3. Raise deck and place 3.25" block under the back of the deck and a 4" block under the front of the deck "FIG. 33". This will set the cutting height at 3-1/2".  
**NOTE: Back of deck will automatically be set approximately 1/4" higher.**
4. Set cutting height at 3-1/2" in the height indicator by placing the height adjusting stop in the 3-1/2" hole, and turning the height stop so that the pin side is against the stop handle "FIG. 34"
5. Clamp the height adjusting stop against the stop handle "FIG. 34". This will assure that the height will not move during the setting process. Otherwise, spring pressure from the deck lift springs will tend to pull the stop away from the handle.

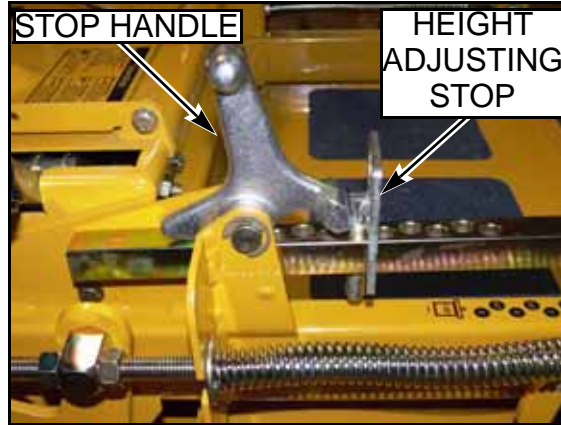

FIG. 34

6. Loosen all nuts on the deck lift threaded rods, and the hardware on the adjuster (on the right front), until **all** the deck lift chains are loose, **and** the deck is sitting tightly on all four blocks "FIG. 35", "FIG. 36", "FIG. 37".

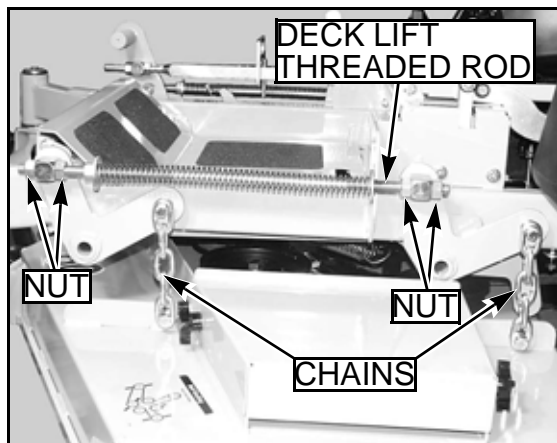

FIG. 35

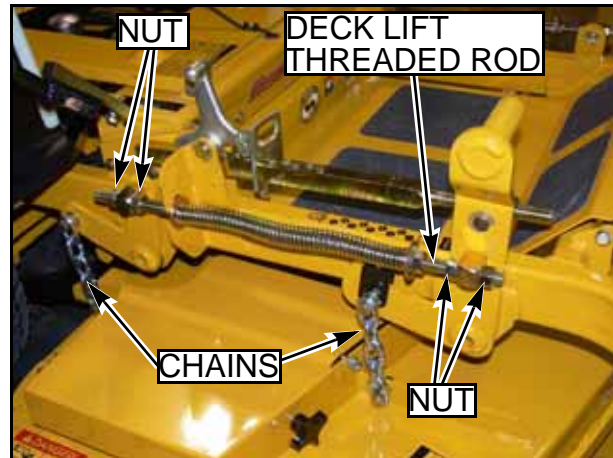

FIG. 36

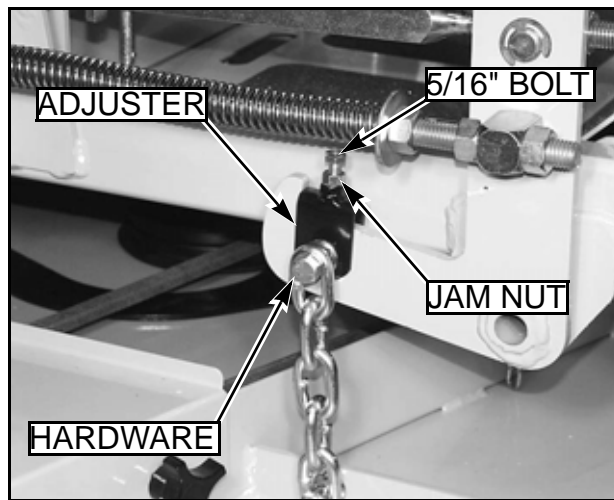

FIG. 37

7. Loosen the two nuts on the front of height indicator so that the foot pedal is free "FIG. 38".
8. Start the leveling process on the **left front** of the tractor.
9. Set the amount of threads protruding on the deck lift rod from the lift block at approximately 1" "FIG. 39".
10. Jam both nuts against the block.
11. Push or pull on the deck lift foot pedal until the chain on the left front just becomes tight, making sure that the deck stays tight against the 4" block.
12. While keeping the chain tight, tighten the nuts against the deck lift block on the height indicator rod, just enough to carry most of the deck weight on that side—the 4" block should be able to move with only a slight drag "FIG. 38".
13. Jam nuts tightly together against the deck lift block.
14. Go to the **right front** of the tractor.
15. Loosen the 5/16" jam nut on the adjuster lift chain "FIG. 37", and back the adjuster bolt out to allow the adjuster to move up and down freely.
16. Be sure that adjuster is free to move up and down.
17. Tighten the adjuster bolt until the chain just becomes tight. Then tighten just enough more to carry the weight of the front of the deck on that side—to check, move the 4" blocks back and forth; they should move with a slight drag.
18. Tighten the adjuster bolt jam nut to prevent the adjuster bolt from moving "FIG. 37".
19. Tighten the hardware holding the chain and adjuster onto the deck lift arm.
20. Go to the **right rear** of the tractor.
21. Make sure that there is still slack in the chain. If not, loosen the two nuts on the block holding the threaded rod until there is slack in the deck lift chain "FIG. 36".
22. Tighten the appropriate nut until the chain just becomes tight, and carries most of the deck weight. Check by moving the 3.25" block—it should move with a slight drag.
23. Tighten the other nut on the opposite side of the block, and jam them tightly together against the block.
24. Go to the left rear of the tractor.
25. Make sure that there is still slack in the chain. If not, loosen the two nuts on the block holding the threaded rod until there is slack in the deck lift chain "FIG. 35".
26. Tighten the appropriate nut until the chain just becomes tight, and carries most of the deck weight. Check by moving the 3.25" block—it should move with a slight drag.
27. Tighten the other nut on the opposite side of the block, and jam them tightly together against the block.
28. Compress the deck lift assist springs so that there is 1" of space between the front nut and on the spring and the rear nut on the deck lift block "FIG. 39". Typical both sides.
29. When completed, all chains will be tight, and deck cutting height will be set to the deck

height indicator.

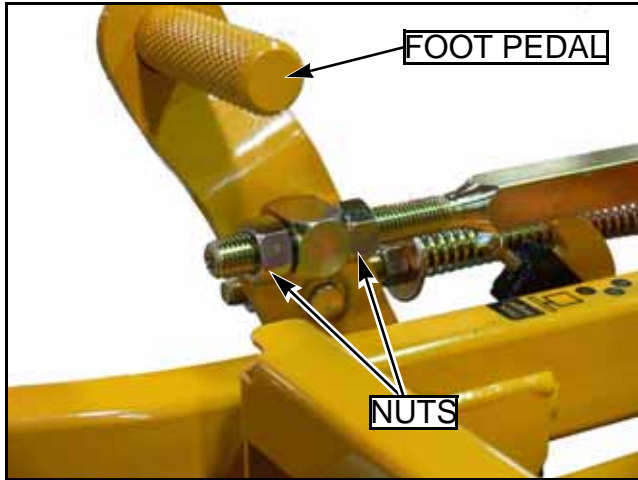

FIG. 38

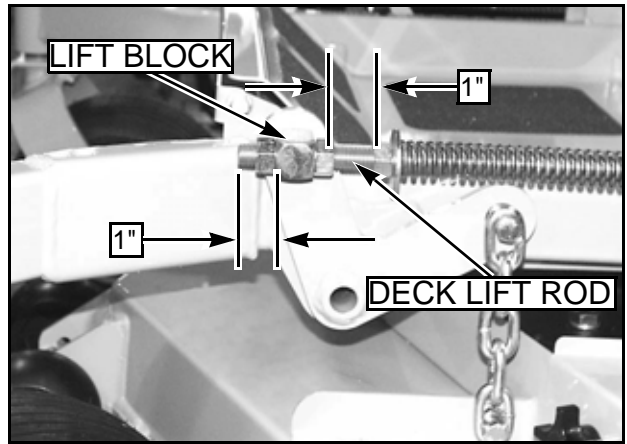

FIG. 39



# Numerical Index

Part No.	Page No.	Part No.	Page No.	Part No.	Page No.
<b>Index</b>					
<b>Part Numbers</b>					
000323	5-5	048876	4-7	109604	3-3, 5-3
000331	5-5, 11-3	051169	9-3	109743	5-3
000398	5-5	052860	2-3, 8-3, 8-7	109748	5-3
000430	5-7	053199	4-9, 8-3, 8-7, 8-13	109948	8-15
005116	4-7, 8-3, 8-7	053660	4-11	110151	5-7
008193	3-3, 4-13, 7-3, 7-5	054502	4-7	110152	5-7
008573	7-5	055749	4-5, 9-3	110402	8-13
012005	8-16, 8-17	055822	4-9, 5-5	110411	8-15
015495	4-5, 4-13, 8-3, 8-7, 8-13	055939	4-3, 5-3	110412	8-15
015511	6-4	055947	3-3, 5-7	110674	4-11
015818	5-5	058776	4-3, 8-5, 8-9, 8-13, 8-15	110677	11-3
016253	8-13	059832	4-7, 5-7, 11-3	110679	4-9
016527	4-13, 8-5, 8-9, 8-15	059931	8-5, 8-9, 8-15	110680	4-11
016642	7-5	060731	5-7	110681	4-11
016899	5-3	061077	6-5	110686	11-3
016972	7-5, 8-5, 8-9, 8-15	061101	4-13, 6-3, 9-3	110855	7-5
017004	5-3	063198	4-7	212076	4-13
017616	7-5	068239	6-6, 11-3	212472	8-5, 8-9, 8-15
018846	4-5	068478	1-1	259812	8-5, 8-15
019521	6-5	068551	3-3, 4-9	263517	6-3
023655	4-7, 4-9, 4-11	072272	8-16	305615	2-3
024927	4-3	077123	8-16, 8-17	314104	8-3, 8-7
025007	8-5, 8-9	077859	3-3, 7-5	344267	6-3
025296	4-13, 6-3, 9-3	078386	7-5, 11-3	347443	8-5, 8-9
025395	8-3, 8-7, 8-11	080358	11-3	347684	4-9
028118	4-13, 8-5, 8-9, 8-15	083196	4-13	347989	5-5
029751	5-3	083279	10-3	348318	4-5
029868	4-3	086660	2-3, 4-7, 4-11, 8-3, 8-7, 8-11, 8-13, 11-3	348391	4-5
029876	4-9, 5-3	089938	7-3, 11-3	348417	4-3
029934	8-5, 8-9, 8-15	103010	8-3, 8-7	348458	4-5
031997	6-6, 8-3, 8-7, 8-13	103184	8-3, 8-7	348714	4-11
032763	3-3	103192	8-9	348755	4-11
032771	3-3	103200	8-9	348797	4-9
033035	3-3, 7-5	106716	8-13	348862	4-11
034272	3-3, 4-3, 4-5, 4-7, 4-9, 4-13, 5-3, 11-3	106732	5-5	348888	4-11
034280	5-3	107620	8-5	348946	4-11
034843	8-16, 8-17	107621	8-5	349266	6-3
036236	4-7, 4-13, 5-3, 7-5, 11-3	108290	11-3	349761	4-13
036244	4-9, 4-11, 5-3, 5-5, 8-13, 11-3	108291	11-3	349803	8-13
037887	8-13	108501	8-7	350264	4-7
039677	6-4	108516	8-11	350330	4-7
041475	6-3	108649	8-3	350397	4-7
044818	5-3	108661	8-11	350421	11-3
045088	5-5	109482	8-13	350884	8-5, 8-9
045765	6-3	109483	8-13	351676	8-13
045898	5-7	109484	8-13	352591	8-13
047654	5-3	109485	8-13	354035	4-7
		109486	8-13	357384	11-3
		109487	8-13	357616	3-3
		109549	8-15	359547	2-3, 10-4, 10-5
				366765	4-13
				373191	8-9

Part No.	Page No.	Part No.	Page No.	Part No.	Page No.
377994	5-3	601555	5-3, 5-7	760637	10-4, 10-5
381657	7-5	601561	5-3	765339	4-7
381665	7-5	601615	1-1	766204	8-16, 8-17
381673	7-5	601616	3-3	767954	2-3, 4-7, 4-9, 4-11, 5-5, 8-3, 8-7, 8-11, 8-13, 11-3
381723	7-5	601626	3-3	767962	3-3, 4-13, 5-5, 6-6, 7-3, 7-5, 8-3, 8-5, 8-7, 8-9, 8-13, 8-15, 11-3
381731	7-5	601627	3-3	768002	7-5
381749	7-5	601628	3-3	768515	3-3, 4-9, 5-3, 5-7
381848	2-2	601629	3-3	768523	3-3, 4-3, 4-7, 4-9, 4-11, 4-13, 5-3, 7-5, 8-5, 8-9, 8-13, 8-15, 11-3
387035	6-3	601631	3-3	769166	5-7
391375	7-5	601647	11-3	769257	8-5, 8-9
392035	7-3	601648	11-3	770842	8-9, 8-15
392191	7-3	601652	1-1, 5-3	770867	8-15, 11-3
392357	7-3	601653	1-1, 5-3	771428	4-3
392597	7-3	601656	1-1	772079	1-1
392605	7-5	601675	5-7	776476	5-7
392613	7-5	601687	3-3	778399	8-13
392985	7-5	601727	4-11	778738	5-3
395533	2-3	601768	4-11	779280	10-3
538850	8-5	601769	4-11	779306	5-5
546572	2-2	601779	8-15	779850	4-3
548438	8-7	601791	10-3	780841	5-3
548453	8-3	601815	10-3	781153	4-11
549576	8-13	601967	10-3	781211	4-7
600221	4-9	601968	10-3	781229	4-5
600254	8-13	601979	7-5	781260	4-11
600296	8-15	601980	10-3	781286	4-9
600437	4-5	700484	3-3	781294	4-5
600893	8-17	704163	4-9	781302	8-5, 8-9, 8-15
600899	10-3	704643	4-5, 9-3	781385	8-5, 8-9
600901	1-1, 8-15	704759	8-15	781427	10-3
600941	10-3	704932	5-7, 11-3	781443	1-1
600961	2-2	705137	5-3	781526	3-3
601016	4-13	705178	4-11	781534	3-3
601053	11-3	705608	3-3	781567	6-6, 7-3, 8-3, 8-7, 8-13, 8-15, 11-3
601069	8-13	705954	5-5, 6-3, 8-5, 8-9	781583	4-11
601089	5-7, 11-3	710194	8-13	781658	3-3
601098	11-3	712257	5-7	781708	8-3, 8-7, 8-13
601130	11-3	712919	5-5	781716	4-9, 4-11
601257	5-3	712927	4-7	781831	4-5
601260	3-3	713198	3-3	781856	4-13, 8-5, 8-9
601264	3-3	714998	5-7	781872	4-13
601265	3-3	720516	5-3	781880	2-3, 11-3
601284	3-3	722199	11-3	781922	4-9
601285	3-3	724716	11-3	782474	8-5, 8-9, 8-15
601311	4-13	727172	10-3, 10-4, 10-5	782573	10-3
601344	4-7	727420	10-4		
601434	8-5, 8-9	727438	10-4, 10-5		
601461	4-13	727453	10-4, 10-5		
601462	4-13	728147	11-3		
601463	4-13	740696	4-3		
601483	8-13	744276	4-3		
601549	5-3	746131	11-3		
601550	5-3	752386	8-5, 8-9, 8-15		
601554	5-7	756270	4-5		

Part No.	Page No.	Part No.	Page No.	Part No.	Page No.
782615	10-3	786285	10-4	794107	5-5
782664	5-3	788018	5-3	794446	8-15
782771	6-4	788042	3-3	794685	1-1, 8-9
782979	4-7	788166	8-3, 8-7, 8-13	795633	1-1, 8-15
782995	4-5	788174	3-3	795781	1-1, 8-15
783001	4-5	788943	5-3	796219	4-3
783118	4-7	789214	7-3	796227	8-16
783126	4-7	789321	4-7	796235X	8-5, 8-9, 8-15
783563	6-5	789339	3-3	796524	5-3
783704	3-3	789404	7-5	796680X	8-15
783712	4-13	789412	7-5	796698	8-17
783738	8-5, 8-9, 8-15	789420	6-5	796714	8-15
783829	4-13	789529	6-5	796722	8-15
783837	5-3	789537	6-4	796953	10-5
783928	3-3	789644	4-7	797076	11-3
783936	1-1, 3-3	791830	10-3	797084	5-5
783993	3-3	792002	8-5, 8-9, 8-15	797449	8-5, 8-9
784025	3-3	792051	11-3	797654	4-13
784066	6-5	792077	7-3	797720	1-1, 8-9
784082	3-3	792887	8-13	797845	10-4, 10-5
784108	3-3	792986	5-5	797910	8-5, 8-9, 8-15
784140	11-3	793232	5-5	798603	6-3
784207	1-1, 8-5	793240	5-5	798694	8-3, 8-7
784223	6-3	793265	11-4	798702	1-1, 8-5
784918	4-13	793273	11-4	799353	10-4
784983	3-4	793281	11-3	799395	10-4
785188	10-3	793299	11-4	808485	8-3, 8-7
785295	5-5	793307	11-3	808493	2-2, 8-3, 8-7
785378	5-3	793315	11-4	928143	1-1
785659	4-13	793323	11-3	928150	1-1
785808	5-7	793588	10-3	928168	1-1
786277	10-4, 10-5	794081	5-5		

<b>Part No.</b>	<b>Page No.</b>	<b>Part No.</b>	<b>Page No.</b>	<b>Part No.</b>	<b>Page No.</b>

## Free Manuals Download Website

<http://myh66.com>

<http://usermanuals.us>

<http://www.somanuals.com>

<http://www.4manuals.cc>

<http://www.manual-lib.com>

<http://www.404manual.com>

<http://www.luxmanual.com>

<http://aubethermostatmanual.com>

Golf course search by state

<http://golfingnear.com>

Email search by domain

<http://emailbydomain.com>

Auto manuals search

<http://auto.somanuals.com>

TV manuals search

<http://tv.somanuals.com>