

HUSSMANN[®]/CHINO

R3, R3P

REF. SERVICE/SELF SERVICE/PREP CASE

Installation
& Operation
Manual

REV. 0608

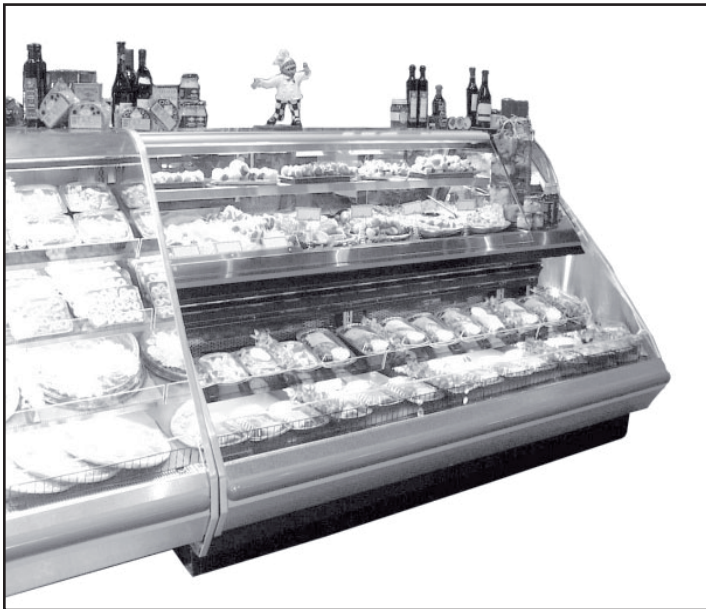

HUSSMANN[®]

R3, R3P
REFRIGERATED SERVICE AND/OR PREP
WITH REFRIGERATED
SELF SERVICE FRONT

P/N IGFP-R3, R3P-0608

INSTALLATION & OPERATION GUIDE

General Instructions

Table of Contents

General Instructions	2
Cut and Plan Views	3
Installation	4
Location.....	4
Uncrating the Stand	4
Exterior Loading	4
Glass Adjustment	4
Setting and Joining.....	4
Leveling.....	4
Corner Wedges	5
Joint Trim.....	5
Scale Stand Installation Instructions	5
Wrapping Boards Installation Instructions.....	6
Bumper Installation Instructions	8
Plumbing	12
Waste Outlet and P-TRAP	12
Installing Condensate Drain	12
Refrigeration	12
Refrigerant Type.....	12
Piping	12
Refrigeration Lines	12
Control Settings.....	12
Access to TX Valves and Drain Lines	12
Electronic Expansion Valve (Optional).....	13
Thermostatic Expansion Valve Location	13
Expansion Valve Adjustment.....	13
Measuring the Operating Superheat.....	13
Evaporator Pressure Regulator.....	13
Service Case Temperature Control	13
T-STAT Location.....	13
Electrical	13
Wiring Color Code.....	13
Electrical Circuit Identification	13
Electrical Service Receptacles (When Applicable).....	13
Field Wiring and Serial Plate Amperage	14
Ballast Location.....	14
User Information	14
Stocking	14
Cleaning Glass and Mirrors.....	14
Replacing Fluorescent Lamps.....	14
Non-glare Glass	15
Plexiglass and Acrylic Care.....	15
Cleaning.....	15
Antistatic Coatings	15
Evaporator Fans.....	15
Copper Coils	15
Tips and Troubleshooting	15
Electrical Wiring Diagrams	16
Wiring Diagrams	17
Appendices	30
Appendix A. - Temperature Guidelines.....	30
Appendix B. - Application Recommendations	30
Appendix C. - Field Recommendations.....	30
Appendix D. - Recommendations to User.....	31

This Booklet Contains Information on:

R3: Refrigerated Service Top/Self-Service Front Case

R3P: Service Prep Top/Refrigerated Self-Service Front Case

R3TO: Service Top only for in-counter installation

Shipping Damage

All equipment should be thoroughly examined for shipping damage before and during unloading.

This equipment has been carefully inspected at our factory and the carrier has assumed responsibility for safe arrival. If damaged, either apparent or concealed, claim must be made to the carrier.

Apparent Loss or Damage

If there is an *obvious loss or damage*, it must be noted on the freight bill or express receipt and signed by the carrier's agent; otherwise, carrier may refuse claim. The carrier will supply necessary claim forms.

Concealed Loss or Damage

When loss or damage *is not apparent until after equipment is uncrated*, a claim for concealed damage is made. Make request in writing to carrier for inspection within 15 days, and retain all packaging. The carrier will supply inspection report and required claim forms.

Shortages

Check your shipment for any possible shortages of material. If a shortage should exist and is found to be the responsibility of Hussmann Chino, *notify Hussmann Chino*. If such a shortage involves the carrier, *notify the carrier immediately*, and request an inspection. Hussmann Chino will acknowledge shortages within ten days from receipt of equipment.

Hussmann Chino Product Control

The serial number and shipping date of all equipment has been recorded in Hussmann's files for warranty and replacement part purposes. All correspondence pertaining to warranty or parts ordering must include the serial number of each piece of equipment involved, in order to provide the customer with the correct parts.

Keep this booklet with the case at all times for future reference.

HUSSMANN®/CHINO

A publication of HUSSMANN® Chino
13770 Ramona Avenue • Chino, California 91710
(909) 628-8942 FAX
(909) 590-4910
(800) 395-9229

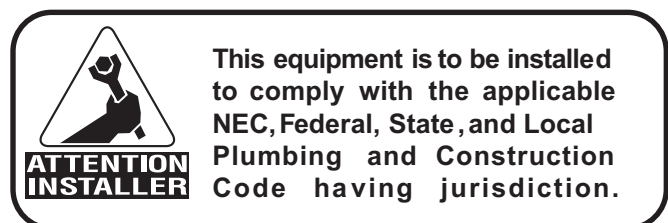

Cut and Plan Views

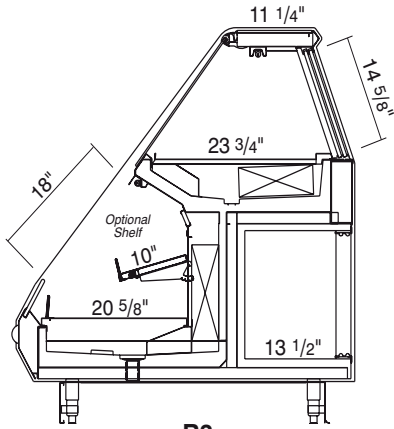

R3
Ref. Service/Self-Service
Scale = 1/2"

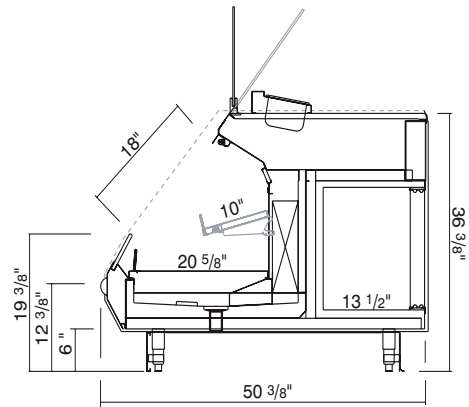

R3P
Service Prep / Self Service Case
Scale = 1/2"

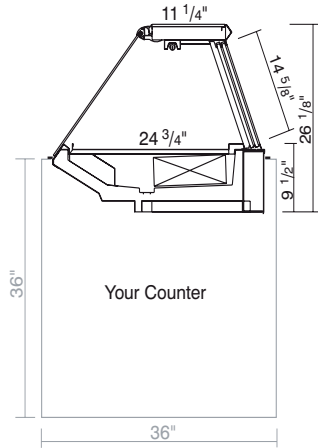

R3TO
Refrigerated
Service /Self Service / Prep Case
Scale = 1/2"

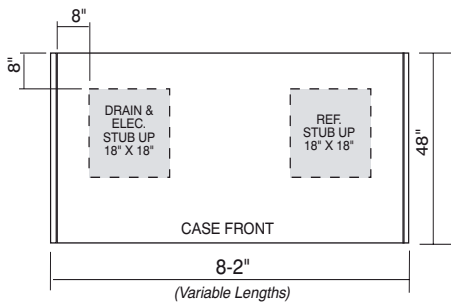

R3
Plan View = 1/4"

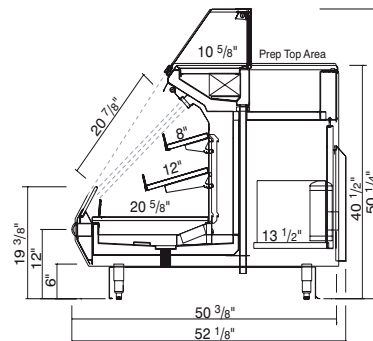

R3 Options
Sushi Service Top and Prep Areas With
Two Shelf Self-Service Options
Self Contained
Scale = 1/2"

Installation

Location

The refrigerated merchandisers have been designed for use only in air conditioned stores where temperature and humidity are maintained at or below 75°F and 55% relative humidity. DO NOT allow air conditioning, electric fans, ovens, open doors or windows (etc.) to create air currents around the merchandiser, as this will impair its correct operation.

Product temperature should always be maintained at a constant and proper temperature. This means that from the time the product is received, through storage, preparation and display, the temperature of the product must be controlled to maximize life of the product.

Uncrating the Stand

Place the fixture as close to its permanent position as possible. Remove the top of the crate. Detach the walls from each other and remove from the skid. Unbolt the case from the skid. The fixture can now be lifted off the crate skid. **Lift only at base of stand!**

Exterior Loading

These models have **not** been structurally designed to support excessive external loading. **Do not walk on their tops;** This could cause serious personal injury and damage to the fixture.

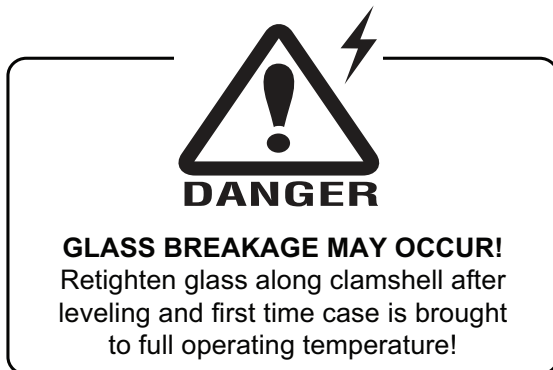

Glass Adjustment

During shipment, the lubricant inside the cylinders may have settled. This settling may cause excessive or uneven tension on the glass - to the point of breakage. To avoid any damage, please follow these three easy steps:

1. Slowly raise and lower each glass section 6 times to a height of 6 inches.
2. Increase the height to 12 inches, and raise and lower the glass 6 more times.
3. Finally raise the glass to its full extension, and lower.

These steps should release any settled lubricant within the cylinders and prevent any stress on the front glass.

Setting and Joining

The sectional construction of these models enable them to be joined in line to give the effect of one continuous display. A joint trim kit is supplied with each joint.

Leveling

IMPORTANT! IT IS IMPERATIVE THAT CASES BE LEVELED FROM FRONT TO BACK AND SIDE TO SIDE PRIOR TO JOINING. A LEVEL CASE IS NECESSARY TO INSURE PROPER OPERATION, WATER DRAINAGE, PLEXIGLASS ALIGNMENT.

NOTE: A. To avoid removing concrete flooring, begin lineup leveling from the highest point of the store floor.

B. When wedges are involved in a lineup, set them first.

All cases were leveled and joined prior to shipment to insure the closest possible fit when cases are joined in the field. When joining, use a carpenter's level and shim legs accordingly. Case must be raised correctly, under legs where support is best, to prevent damage to case.

1. Check level of floor where cases are to be set. Determine the highest point of the floor; cases will be set off this point.
2. Set first case, and adjust legs over the highest part of the floor so that case is level. Prevent damage - case must be raised under leg or by use of 2x6 or 2x4 leg brace. Remove side and back leg braces after case is set.
3. Set second case as close as possible to the first case and level case to the first using the instructions in step one.
4. Apply masking tape 1/8" in from end of case on inside and outside rear mullion on both cases to be joined.
5. Apply liberal bead of case joint sealant (butyl) to (dotted area shown in figure) first case. Apply heavy amount to cover entire shaded area.

DO NOT USE PERMAGUM!



6. Slide second case up to first case snugly. Then level second case to the first case so glass front, bumper and top are flush.
7. To compress silicone at joint, use two Jurgenson wood clamps. Make sure case is level from front to back and side to side on inside bulkheads at joint.
8. Attach sections together via a 2 bolts located in the base of the case. Secure the overhead structure by bolting the bracket, located inside behind lights.
9. Apply bead of silicone to top of bulkheads and slip on stainless steel bulkhead cap. Also apply silicone to seam between overhead light tubes.

Installation (Cont'd)

10. Use finger to smooth silicone as thin as possible at masking tape on inside and outside of rear mullion (apply additional silicone if necessary). Remove tape applied on line #3.

Corner Wedges

Corner wedges are attached via front and rear camlocks. Use a 7mm allen wrench to turn the locks. Do not overtighten! Join the top by using a joint bracket (included in joint kit) with 3/8" bolts.

Joint Trim

After cases have been leveled and joined, and refrigeration, electrical, and wasted piping work completed, install the splashguards. Fasten along the top edge, or center, with #10 X 3/3" sheet metal screws.

DO NOT SEAL JOINT TRIM TO FLOOR!

Scale Stand Installation Instructions



1.- Set Scale Stand to desire location

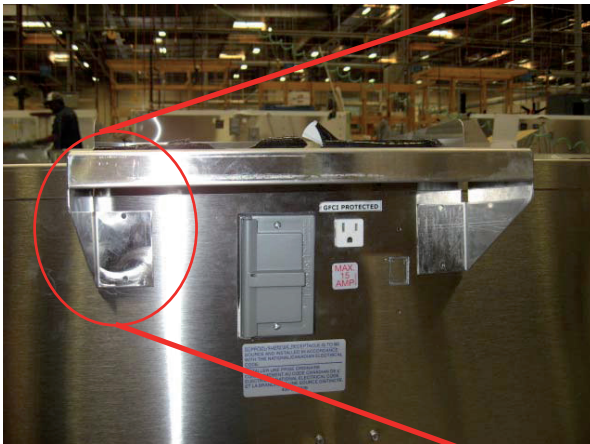

2.- Drill holes and screw in place
(with screws provided – Hex Tek S/S
10-16 X 1/2")

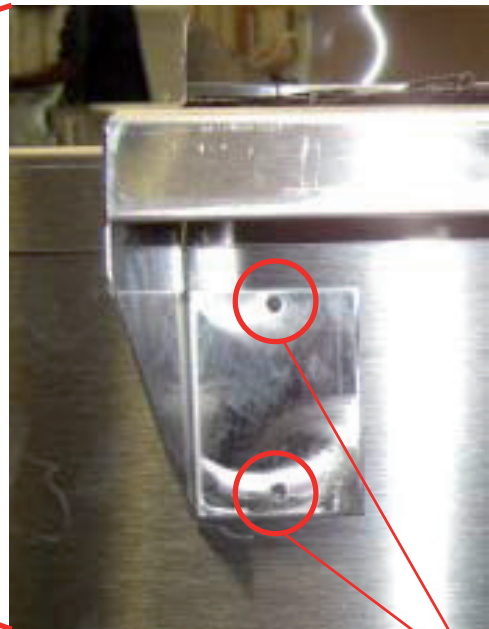

Note: Use hole pattern

Installation (Cont'd)

Wrapping Boards Installation Instructions



Step 1: Measure 6 inches from wrapping board end.



Step 2: Measure 10 inches from top of the case.

Note: Line up 6 inch mark with 10 inch mark.



Step 3: Use bracket center hole to align with cross mark.

Note: Use pencil/marker to mark hole pattern.

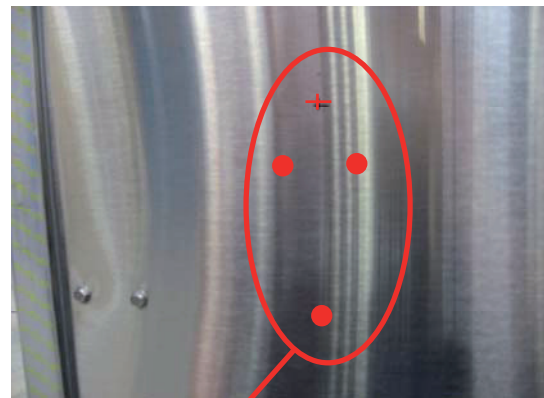

HOLE PATTERN

Step 4: Drill holes (7/32")

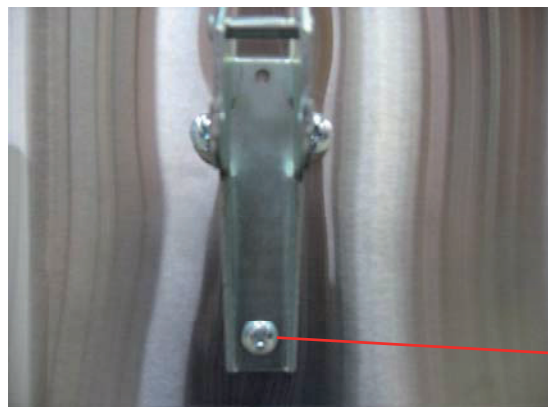

Screws # 14 X 1"

Step 5: Install bracket with screws (provided)

Note: Repeat Steps 1 Thru 5 for Second Bracket Installation.

Installation (Cont'd)

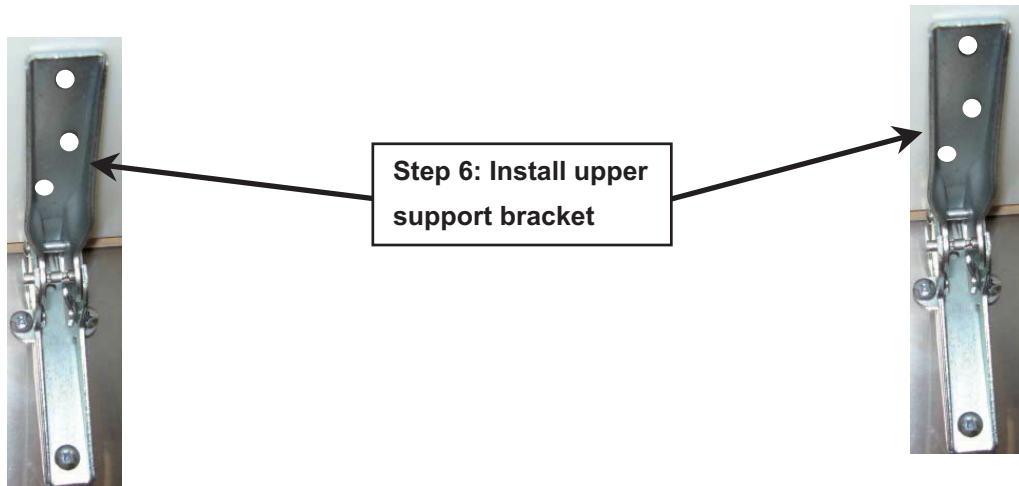

Step 7: Mount wrap board on top of bracket using a 1/4" spacer to have a gap between rear wall and board.



Step 8: screw bracket into wrap board (screws provided -#8 X 1 1/4")



Installation Complete

Installation (Cont'd)

Bumper Installation Instructions



Step 1: Make sure the aluminum channel and end caps are installed.



Step 2: Use silicone lubricant to help the bumper slide into the channel.



Step 3: Starting on one end: while inserting the bumper, push it up against the end cap to prevent the bumper from shrinking after installation (when it gets cold).



Step 4: As you insert the bumper into the channel with one hand, pull the bumper toward you with the other to open the inside lips. Slowly apply pressure by rolling the bumper into the track.

Installation (Cont'd)

Boston Series 2000

NOTE: Flexible top: Over cut vinyl 1/8" for every 4' section for the flexible top to ensure a proper fit.

NOTE: Rigid Top: Do not over cut.



1. Attach the base and end/corner cap to the desired surface by inserting #8 pan head screws through the pre-slotted holes in both the end cap and the base. Insert screws through the two holes of end cap and tighten.



- 2a. **Flexible Top:** Butt end of the vinyl top against end/corner cap. While applying pressure, bend back vinyl top so that vinyl legs are positioned within the base grooves. Roll vinyl top over full length of base, then tap with rubber mallet to ensure vinyl is securely locked into the base.
 - 2b. **Rigid Top:** Snap the Rigid Top over the Rigid Base.

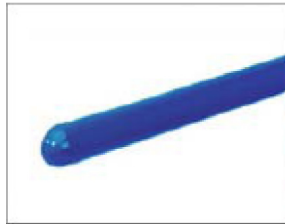

3. If necessary wipe clean with any household cleaning product.

Helpful Hints:

- For best results, before cutting, install a scrap piece of base into vinyl top to achieve a clean cut.
- Set the uncoiled flexible vinyl at room temperature 24 hours prior to installation.
- Lubricate the inside of the vinyl with soapy water or silicone before installing.
- Over cut the flexible vinyl and compression fit. Adding the additional materials will compensate for stretching which occurs during installation.

Installation (Cont'd)

Boston 2000 Eco Series



1. Attach the base and end/corner cap to the desired surface by inserting #8 pan head screws through the pre-slotted holes in both the end cap and the base. Insert screws through the two holes of end cap and tighten.



- 2a. **Flexible Top:** Butt end of the vinyl top against end/corner cap. While applying pressure, bend back vinyl top so that vinyl legs are positioned within the base grooves. Roll vinyl top over full length of base, then tap with rubber mallet to ensure vinyl is securely locked into the base.
- 2b. **Rigid Top:** Snap the Rigid Top over the Rigid Base.



3. If necessary wipe clean with any household cleaning product.

Helpful Hints:

- For best results, before cutting, install a scrap piece of base into vinyl top to achieve a clean cut.
- Set the uncoiled flexible vinyl at room temperature 24 hours prior to installation.
- Lubricate the inside of the vinyl with soapy water or silicone before installing.
- Over cut the flexible vinyl and compression fit. Adding the additional materials will compensate for stretching which occurs during installation.

Installation (Cont'd)

Boston 1000 Series

NOTE: Flexible top: Over cut vinyl 1/8" for every 4' section for the flexible top to ensure a proper fit.

NOTE: Rigid Top: Do not over cut.

Installation



1. Attach the base and end/corner cap to the desired surface by inserting #8 pan head screws through the pre-slotted holes in both the end cap and the base. Insert screws through the two holes of end cap and tighten.



- 2a. **Flexible Top:** Butt end of the vinyl top against end/corner cap. While applying pressure, bend back vinyl top so that vinyl legs are positioned within the base grooves. Roll vinyl top over full length of base, then tap with rubber mallet to ensure vinyl is securely locked into the base.
 - 2b. **Rigid Top:** Snap the Rigid Top over the Rigid Base.



3. If necessary wipe clean with any household cleaning product.

Helpful Hints:

- For best results, before cutting, install a scrap piece of base into vinyl top to achieve a clean cut.
- Set the uncoiled flexible vinyl at room temperature 24 hours prior to installation.
- Lubricate the inside of the vinyl with soapy water or silicone before installing.
- Over cut the flexible vinyl and compression fit. Adding the additional materials will compensate for stretching which occurs during installation.

Plumbing

Waste Outlet and P-TRAP

The waste outlet is located off the center of the case on one side allowing drip piping to be run lengthwise under the fixture. There are 3 drains in each fixture that can be easily located.

1-1/2", 1" and 3/4" P-TRAPS and threaded adapters are supplied with each fixture. The 3 P-TRAPS must be installed to prevent air leakage and insect entrance into the fixture.

NOTE: PVC-DWV solvent cement is recommended. Follow the manufacturer's instructions.

Installing Condensate Drain

Poorly or improperly installed condensate drains can seriously interfere with the operation of this refrigerator, and result in costly maintenance and product losses. Please follow the recommendations listed below when installing condensate drains to insure a proper installation:

1. Never use pipe for condensate drains smaller than the nominal diameter of the pipe or P-TRAP supplied with the case.
2. When connecting condensate drains, the P-TRAP must be used as part of the condensate drain to prevent air leakage or insect entrance. Store plumbing system floor drains should be at least 14" off the center of the case to allow use of the P-TRAP pipe section. Never use two water seals in series in any one line. Double P-TRAPS in series will cause a lock and prevent draining.

3. Always provide as much down hill slope ("fall") as possible; 1/8" per foot is the preferred minimum. PVC pipe, when used, must be supported to maintain the 1/8" pitch and to prevent warping.
4. Avoid long runs of condensate drains. Long runs make it impossible to provide the "fall" necessary for good drainage.
5. Provide a suitable air break between the flood rim of the floor drain and outlet of condensate drain. 1" is ideal.
6. Prevent condensate drains from freezing:
 - a. Do not install condensate drains in contact with non-insulated suction lines. Suction lines should be insulated with a non - absorbent insulation material such as Armstrong's Armaflex.
 - b. Where condensate drains are located in dead air spaces (between refrigerators or between a refrigerator and a wall), provide means to prevent freezing. The water seal should be insulated to prevent condensation.

Refrigeration

Refrigerant Type

The standard refrigerant will be R-22 unless otherwise specified on the customer order. Check the serial plate on the case for information.

Piping

The refrigerant line outlets are located under the case. Locate first the electrical box, the outlets are then on the same side of the case but at the opposite end. Insulate suction lines to prevent condensation drippage.

Refrigeration Lines

<u>Liquid</u>	<u>Suction</u>
3/8" O.D.	5/8" O.D.

NOTE: The standard coil is piped at 5/8" (suction); however, the store tie-in may vary depending on the number of coils and the draw the case has. Depending on the case setup, the connecting point in the store may be 5/8", 7/8", or 1 1/8". Refer to the particular case you are hooking up.

Refrigerant lines should be sized as shown on the refrigeration legend furnished by the store.

Install **P-TRAPS** (oil traps) at the base of all suction line vertical risers.

Pressure drop can rob the system of capacity. To keep the pressure drop to a minimum, keep refrigerant line run as short as possible, using the minimum number of elbows. Where elbows are required, use long radius elbows only.

Control Settings

See R3, R3P technical data sheet for the appropriate settings for your merchandiser. Maintain these parameters to achieve near constant product temperatures. Product temperature should be measured first thing in the morning, after having been refrigerated overnight. Defrost times should be as follows: OFF CYCLE - Defrost times should be as directed in the R3, R3P technical data sheet. The number of defrosts per day and the duration of the defrost cycle may be adjusted to meet conditions present at your location.

Access to TX Valves and Drain Lines

Mechanical - Remove product from end of case. Remove product racks. Remove refrigeration and drain access panels (labeled). TX valve (mechanical only) and drain are located under each access panel at end of the case.

Electronic - The Electronic Expansion valve master and slave cylinder(s) are located within the electrical access panel(s).

Refrigeration (Cont'd)

Electronic Expansion Valve (Optional)

A wide variety of electronic expansion valves and case controllers can be utilized. Please refer to EEV and controller manufacturers information sheet. Sensors for electronic expansion valves will be installed on the coil inlet, coil outlet, and in the discharge air. (Some supermarkets require a 4th sensor in the return air). Case controllers will be located in the electrical raceway or under the case. The front Self Service Evaporator has an EPR valve installed to maintain a constant discharge temperature. It is located in the front at the right side of the case under the fan plenum near the TX valve.

Thermostatic Expansion Valve Location

This device is located on the same side as the refrigeration stub. A Sporlan balanced port expansion valve model is furnished as standard equipment, unless otherwise specified by customer.

Expansion Valve Adjustment

Expansion valves must be adjusted to fully feed the evaporator. Before attempting any adjustments, make sure the evaporator is either clear or very lightly covered with frost, and that the fixture is within 10°F of its expected operating temperature.

Measuring the Operating Superheat

1. Determine the suction pressure with an accurate pressure gauge at the evaporator outlet.
2. From a refrigerant pressure temperature chart, determine the saturation temperature at the observed suction pressure.
3. Measure the temperature of the suction gas at the thermostatic remote bulb location.

4. Subtract the saturation temperature obtained in step No. 2 from the temperature measured in step No. 3. The difference is superheat.
5. Set the superheat for 5°F - 7°F.

Evaporator Pressure Regulator

An Evaporator Pressure Regulator is installed in the front of the self service section to maintain a constant discharge temperature. It is located at the front right side of the case, under the fan plenum near the TX Valve.

Service Case Temperature Control

Temperature control in the upper section of the R3 with the Service Option is done by means of a thermostat and suction solenoid valve. This controls both temperature and humidity.

T-STAT Location

T-STATS are located within the electrical raceway. Refer to diagram below.

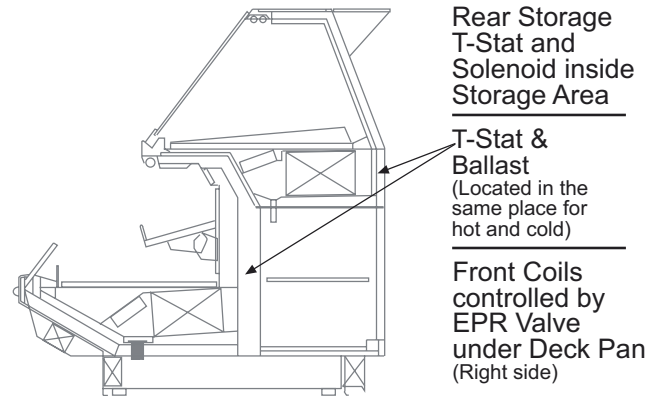

Electrical

Wiring Color Code

STANDARD CASE WIRE COLOR CODE CODIGO DE COLORES DE LOS ALAMBRES PARA LAS VITRINAS ESTANDAR CODE COULEUR POUR FILS DE BOITIER NORMALISE		
COLOR DESCRIPTION	DESCRIPCION	DESCRIPTION
■ GROUND	TIERRA MASA	MASSE
■ ANTI-SWEAT	ANTICONDENSACION	ANTI-SUINTEMENT
■ LIGHTS	LUCES	ECLAIRAGE
■ RECEPTACLES	ENCHUFES	PRISE DE COURANT
■ T-STAT/SOLENOID 230VAC	TERMOSTATO/SOLENOIDE (230VAC)	SOUPAPE A SOLENOID (230 VAC)
■ T-STAT/SOLENOID 115VAC	TERMOSTATO/SOLENOIDE (115VAC)	SOUPAPE A SOLENOID (115 VAC)
■ T-STAT/SOLENOID 24VAC	TERMOSTATO/SOLENOIDE (24VAC)	SOUPAPE A SOLENOID (24 VAC)
■ FAN MOTORS	VENTILADORES	VENTILATEUR
■ BLUE CONDENSING UNIT	UNIDAD DE CONDENSACION	UNITE DE CONDENSATION

USE COPPER CONDUCTORS ONLY
UTILISEZ LES CONDUCTEURS DE CUIVRE SEULEMENT
UTILICE LOS CONDUCTORES DE COBRE SOLAMENTE
 430-01-0338 R101003

CASE MUST BE GROUNDED

NOTE: Refer to label affixed to case to determine the actual configuration as checked in the "TYPE INSTALLED" boxes.

Electrical Circuit Identification

Standard lighting for all refrigerated models will be full length fluorescent lamps located within the case at the top.

The switch controlling the lights, the plug provided for digital scale, and the thermometer are located at the rear of the case mullion.

The receptacle that is provided on the exterior back of these models is intended for computerized scales with a five amp maximum load, not for large motors or other high wattage appliances. It should be wired to a dedicated circuit.

Electrical Service Receptacles (When Applicable)

The receptacles located on the exterior of the merchandiser are intended for scales and lighted displays. They are not intended nor suitable for large motors or other external appliances.

Electrical (Cont'd)



**BEFORE SERVICING
ALWAYS DISCONNECT ELECTRICAL
POWER AT THE MAIN DISCONNECT
WHEN SERVICING OR REPLACING ANY
ELECTRICAL COMPONENT.**

**This includes (but not limited to) Fans, Heaters
Thermostats, and Lights.**

Field Wiring and Serial Plate Amperage

Field Wiring must be sized for component amperes printed on the serial plate. Actual ampere draw may be less than specified. Field wiring from the refrigeration control panel to the merchandisers is required for refrigeration thermostats. Most component amperes are listed in the "Case Specs" section, but always check the serial plate.

Ballast Location

Ballasts are located within the access panel that runs the length of the rear of the case.

User Information

Stocking

Improper temperature and lighting will cause serious product loss. Discoloration, dehydration and spoilage can be controlled with proper use of the equipment and handling of product. Product temperature should always be maintained at a constant and proper temperature. This means that from the time the product is received, through storage, preparation and display, the temperature of the product must be controlled to maximize life of the product. Hussmann cases were not designed to "heat up" or "cool down" product - but rather to maintain an item's proper temperature for maximum shelf life. To achieve the protection required always:

1. Minimize processing time to avoid damaging temperature rise to the product. Product should be at proper temperature.
2. Keep the air in and around the case area free of foreign gasses and fumes or food will rapidly deteriorate.
3. Maintain the display merchandisers temperature controls as outlined in the refrigerator section of this manual.
4. Do not place any product into these refrigerators until all controls have been adjusted and they are operating at the proper temperature. Allow merchandiser to operate a minimum of 6 hours before stocking with any product.
5. When stocking, never allow the product to extend beyond the recommended load limit. **Air discharge and return air flow must be unobstructed at all times to provide proper refrigeration.**
6. Keep the service doors closed (when applicable). Refrigeration performance will be seriously affected if left open for a prolonged period of time.
7. Avoid the use of supplemental flood or spot lighting. Display light intensity has been designed for maximum visibility and product life at the factory. The use of higher output fluorescent lamps (H.O. and V.H.O.), will shorten the shelf life of the product.



**IMPORTANT
INFORMATION**

FOR PROMPT SERVICE

**When Contacting the Factory regarding problems.
Be sure to have the Case MODEL and
SERIAL NUMBER Handy. This Information
is on a plate located on the case itself.**

Cleaning Glass and Mirrors

Only use a soft cloth and mild glass cleaning for cleaning any glass or mirrored components. Be sure to rinse and/or dry completely.

Never use hot water on cold glass surfaces! It may shatter and cause serious injury! Allow glass surfaces to warm first.

Replacing Fluorescent Lamps

Fluorescent lamps are furnished with a shatterproof protective coating. The same type of lamp with protective coating must be used if replaced.

HUSSMANN®

ENCAPSULITE

SHATTERPROOF COATING - SA 10645

®

Complies with FDA USDA
& OSHA Regulations

NSF

for replacement call:

1-800-395-9229

→ Turn switch off then on after replacing bulb ←

User Information (Cont'd)

Non-glare Glass

Windex® or Glass Plus® are the only solutions recommended to be used to clean the non-glare glass. The damage to the glass from improper, caustic solutions is irreparable.

In addition to cleaning the glass with the recommended product, there are precautions that should be taken when working and cleaning the inside of the case.

- When cleaning the inside of the cases, we recommend that the glass be fully opened and covered to prevent solutions from splashing onto the glass and ruining the coating on the inside.

Plexiglass and Acrylic Care

Improper cleaning not only accelerates the cleaning cycle but also degrades the quality of this surface. Normal daily buffing motions can generate static cling attracting dust to the surface. Incorrect cleaning agents or cleaning cloths can cause micro scratching of the surface, causing the plastic to haze over time.

Cleaning

Hussmann recommends using a clean damp chamois, or a paper towel marketed as dust and abrasive free with **210® Plastic Cleaner and Polish** available by calling Sumner Labs at **1-800-542-8656**. Hard, rough cloths or paper towels will scratch the acrylic and should not be used.

Antistatic Coatings

The **210®** has proven to be very effective in not only cleaning and polishing the Plexiglass surface, but also providing antistatic and anti-fog capabilities. This product also seals pores and provides a protective coating.



PRECAUTION CLEANING PRECAUTIONS

When cleaning:

- Do not use high pressure water hoses
- Do not introduce water faster than waste outlet can drain
- NEVER ON A SELF CONTAINED UNIT WITH AN EVAPORATOR FAN
- NEVER USE A CLEANING OR SANITIZING SOLUTION THAT HAS AN OIL BASE (these will dissolve the butyl sealants) or an AMMONIA BASE (this will corrode the copper components of the case)

TO PRESERVE THE ATTRACTIVE FINISH:

- DO USE WATER AND A MILD DETERGENT FOR THE EXTERIOR ONLY
- DO NOT USE ABRASIVES OR STEEL WOOL SCOURING PADS (these will mar the finish)

Evaporator Fans

The evaporator fans are located at the center front of these *merchandisers directly beneath the display pans*. Should fans or blades need servicing, always replace fan blades with the raised embossed side of the blade **TOWARD THE MOTOR**.

Copper Coils

The copper coils used in Hussmann merchandisers may be repaired in the field. Materials are available from local refrigeration wholesalers.

Hussmann recommends using #15 Sil-Fos for repairs.

Tips and Troubleshooting

Before calling for service, check the following:

1. Check electrical power supply to the equipment for connection.
2. Check fixture loading. Overstocking case will affect its proper operation.
3. If frost is collecting on fixture and/or product, check that no outside doors or windows are open - allowing moisture to enter store. These merchandisers were designed for use in stores where temperature & humidity does not exceed 75° F and 55% H.

Electrical Wiring Diagrams

R3 Prep		4'	W0180047
		6'	W0180048
		8'	W0180049
		12'	W0180051
R3-P-8-REM		8'	W1800167
R3-P-4-REM WALMART		4'	W1800172
R3-P-6-REM WALMART		6'	W1800173
R3 Top Only - Cold		4'	W0180101
		6'	W0180102
		8'	W0180103
		12'	W0180105
R3TO 2000 S/C	TOP ONLY BLOWER	4'	W1800122

Wiring Diagrams

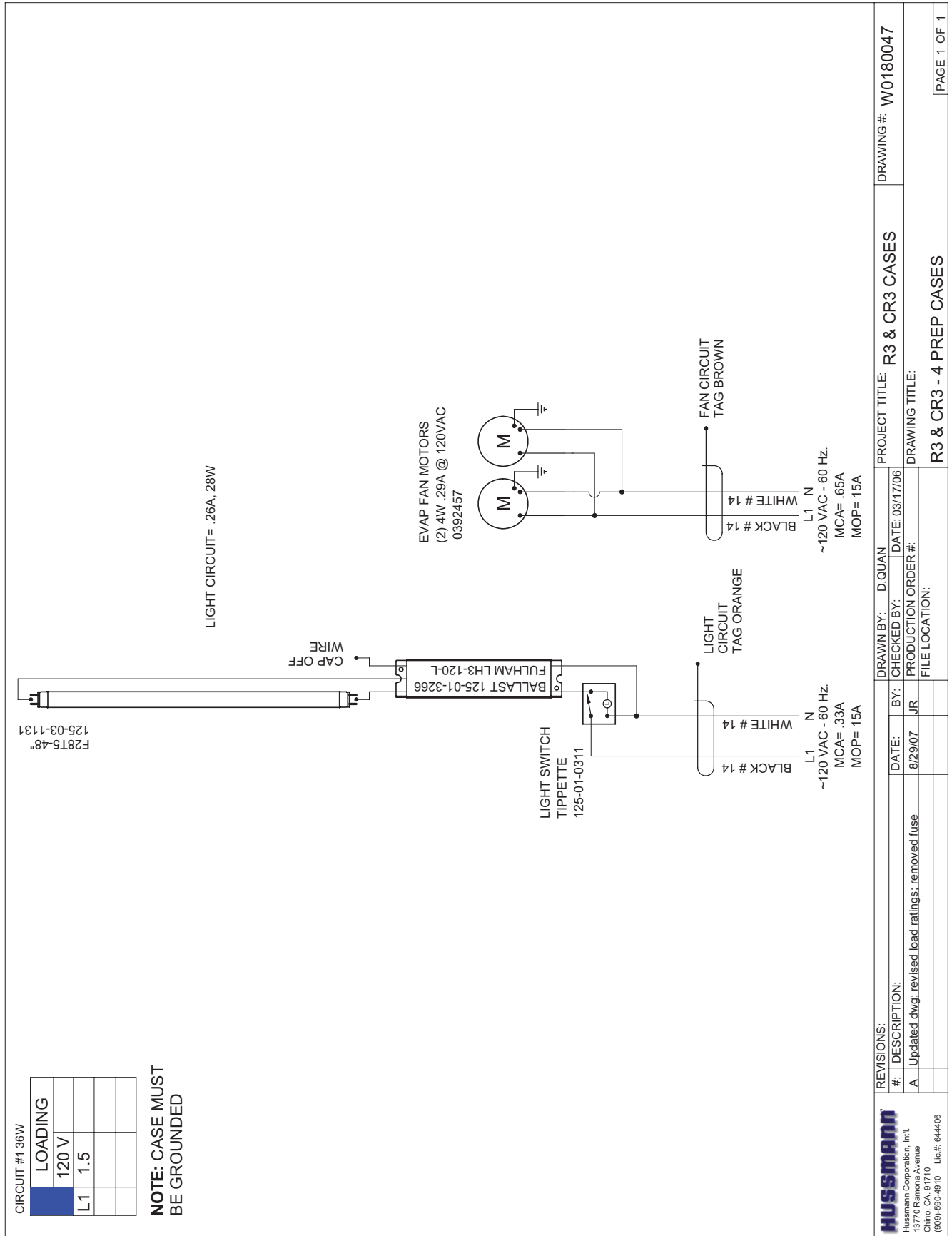

Wiring Diagrams (Cont'd)

CIRCUIT #1 58W

LOADING	
120 V	
L1	1.6

NOTE: CASE MUST BE GROUNDED

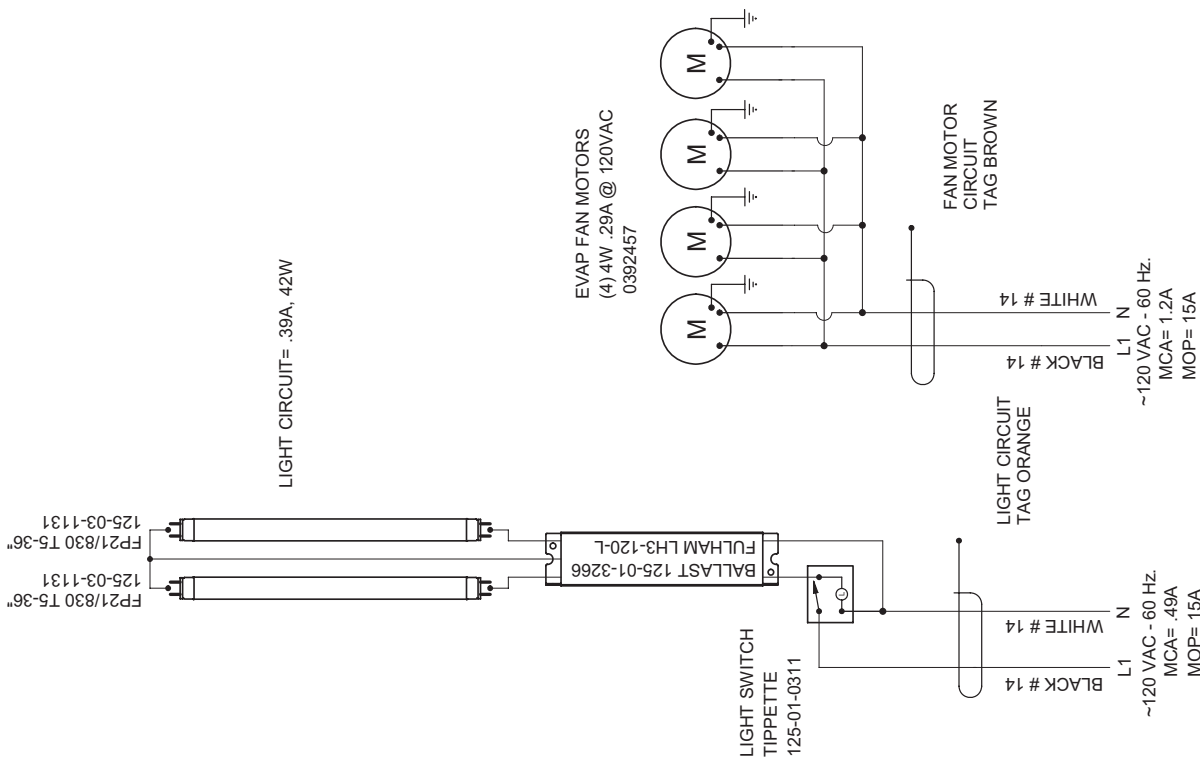

REVISIONS:		DRAWN BY: D.QUAN	PROJECT TITLE: R3 & CR3 CASES	DRAWING #: W0180048
#:	DESCRIPTION:	DATE:	DATE: 03/17/06	
A	Updated dwg: revised load ratings: removed fuse	8/29/07	PRODUCTION ORDER #:	
			FILE LOCATION:	R3 & CR3 - 6 PREP CASES
				PAGE 1 OF 1

HUSSMANN
 Hussmann Corporation, Inc.
 13770 Central Expressway
 Chino, CA 91710
 (909) 590-4810 Lic.# 644406

Wiring Diagrams (Cont'd)

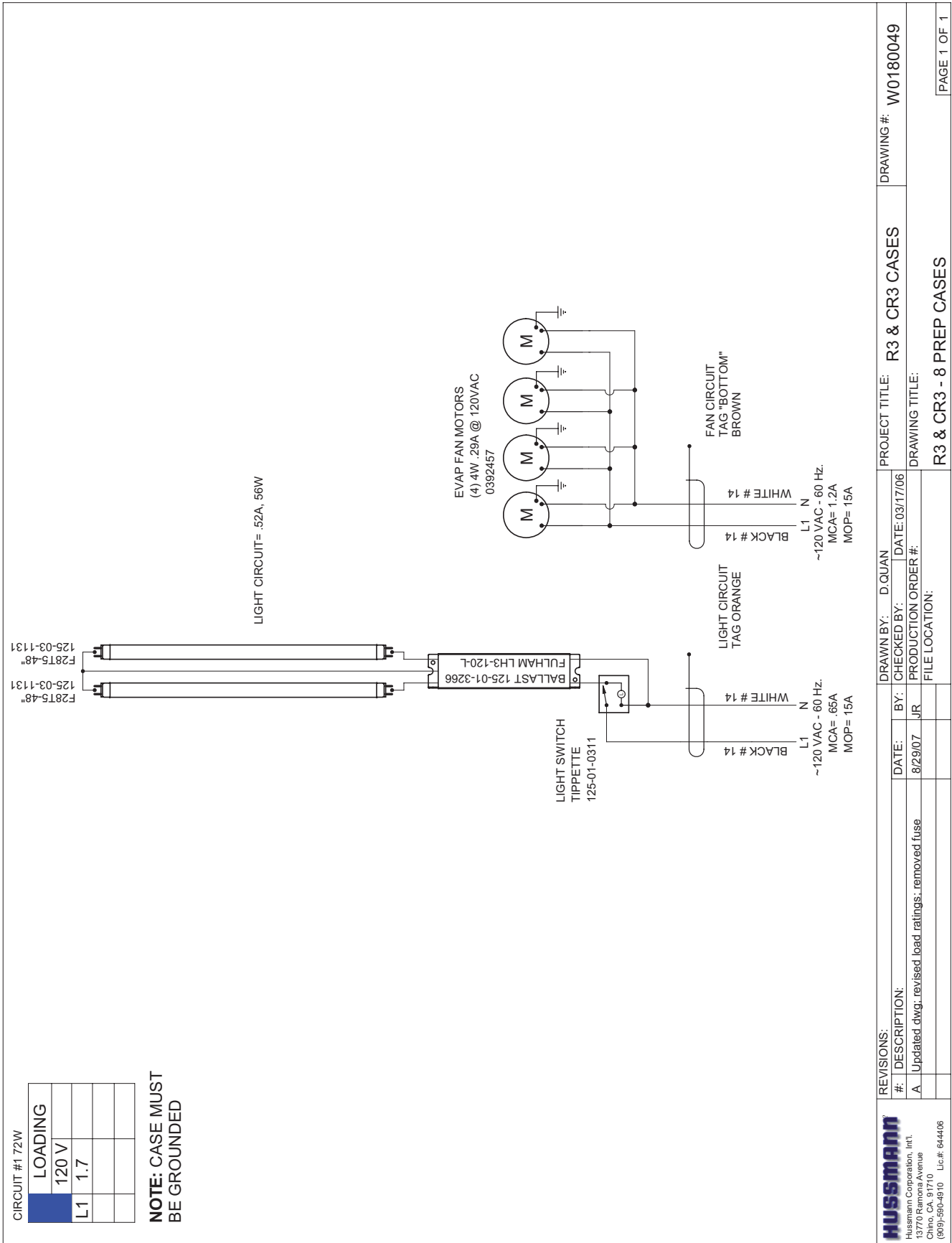

Wiring Diagrams (Cont'd)

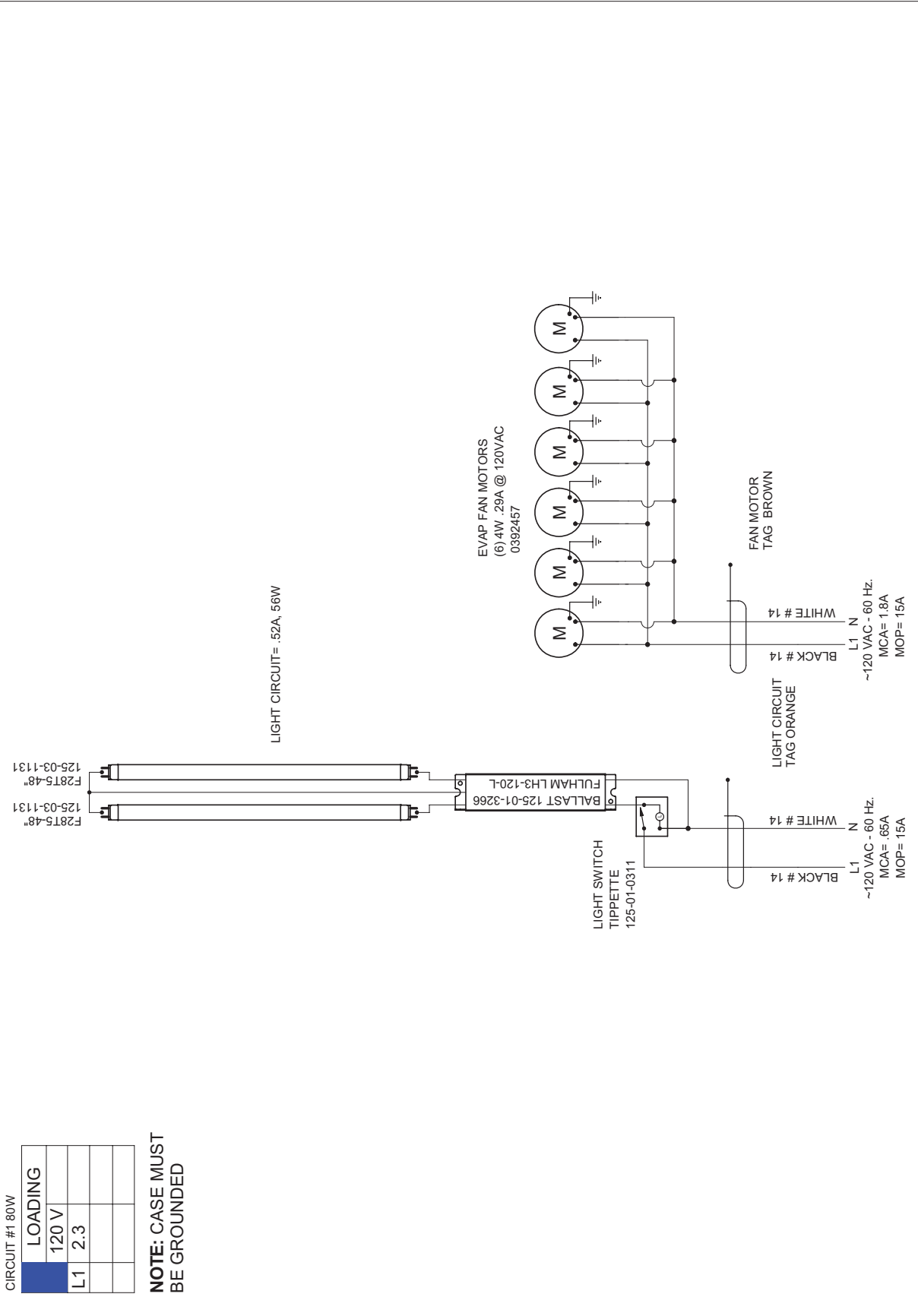

REVISIONS:	DRAWN BY: D.QUAN	PROJECT TITLE: R3 & CR3 CASES	DRAWING #: W0180051
#: DESCRIPTION:	BY: CHECKED BY: DATE: 03/17/06		
A Updated dwg: revised load ratings: removed fuse	JR PRODUCTION ORDER #:		
	FILE LOCATION:	R3 & CR3 - 12 PREP CASES	PAGE 1 OF 1

HUSSMANN
 Hussmann Corporation, Inc.
 13770 Central Expressway
 Chino, CA 91710 Lic.# 644406
 (909) 590-4810

Wiring Diagrams (Cont'd)

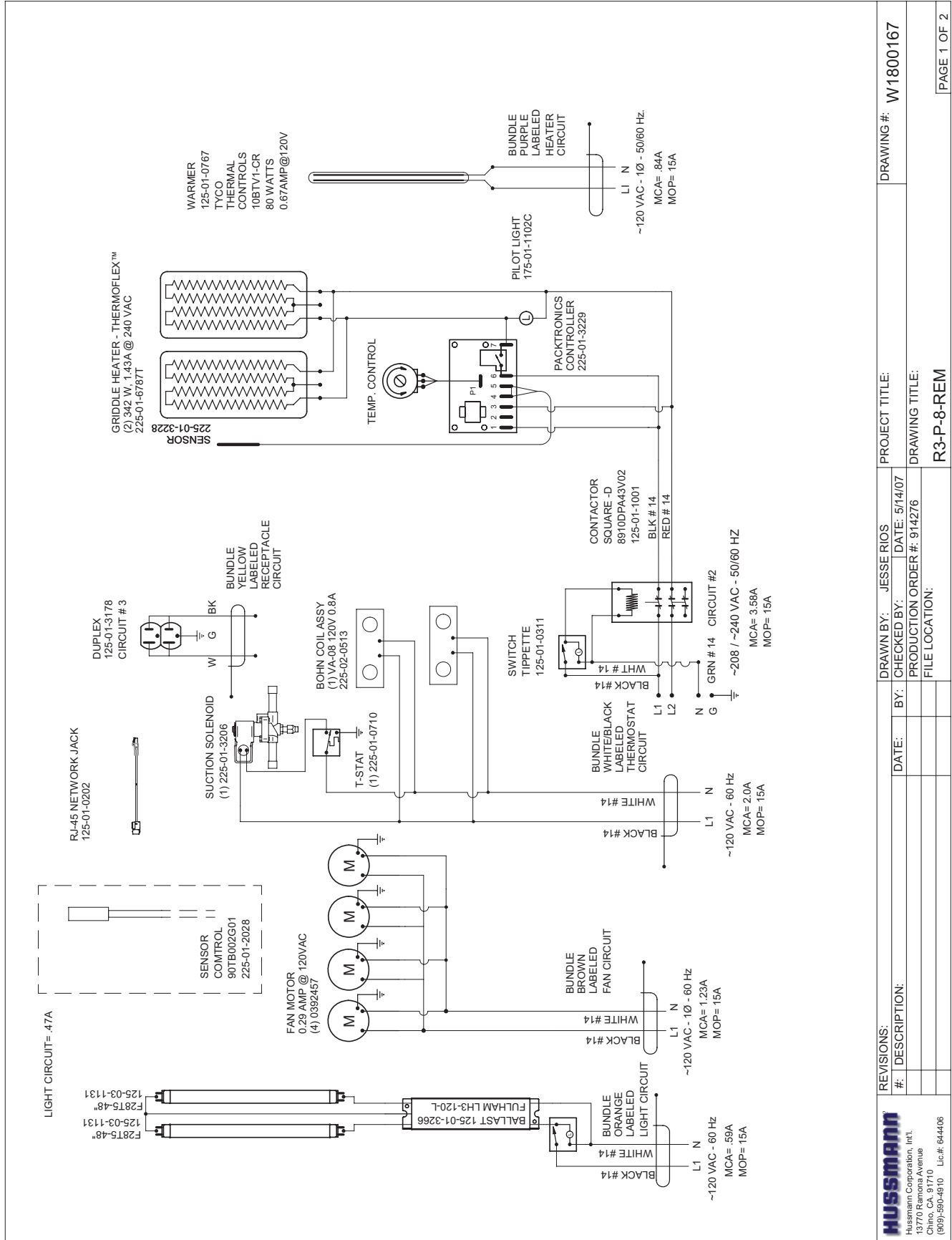

REVISIONS: # : DESCRIPTION:		DRAWN BY: JESSE RIOS		PROJECT TITLE:	
DATE:		CHECKED BY:		DATE: 5/14/07	
BY:		PRODUCTION ORDER #: 914276		DRAWING TITLE:	
FILE LOCATION:		R3-P-8-REM		DRAWING #: W1800167	
PAGE 1 OF 2					

HUSSMANN
 Hussmann Corporation, Inc.
 13770 Central Expressway
 Chino, CA 91710
 (909) 590-4810 Lic.# 644406

Wiring Diagrams (Cont'd)

CIRCUIT #1

LOADING	
120 V	
L1	3.9
L2	
L3	

NOTE: CASE MUST BE GROUNDED

CIRCUIT #2

LOADING	
208 V 240V	
L1	5.0 5.7
L2	5.0 5.7
L3	

NOTE: CASE MUST BE GROUNDED

CIRCUIT #3

LOADING	
120 V	
L1	15.0
L2	
L3	

NOTE: CASE MUST BE GROUNDED

HUSSMANN
 Hussmann Corporation, Inc.
 5370 Westinghouse Avenue
 Chula Vista, CA 91910 Lic.# 644406
 (619)-590-4810

REVISIONS:
 # DESCRIPTION:

DATE: BY:

DRAWN BY: JESSE RIOS
 CHECKED BY: DATE: 4/12/07
 PRODUCTION ORDER #: 914276
 FILE LOCATION:

PROJECT TITLE:
 DRAWING TITLE:

DRAWING #: W1800167
 R3-P-8REM

Wiring Diagrams (Cont'd)

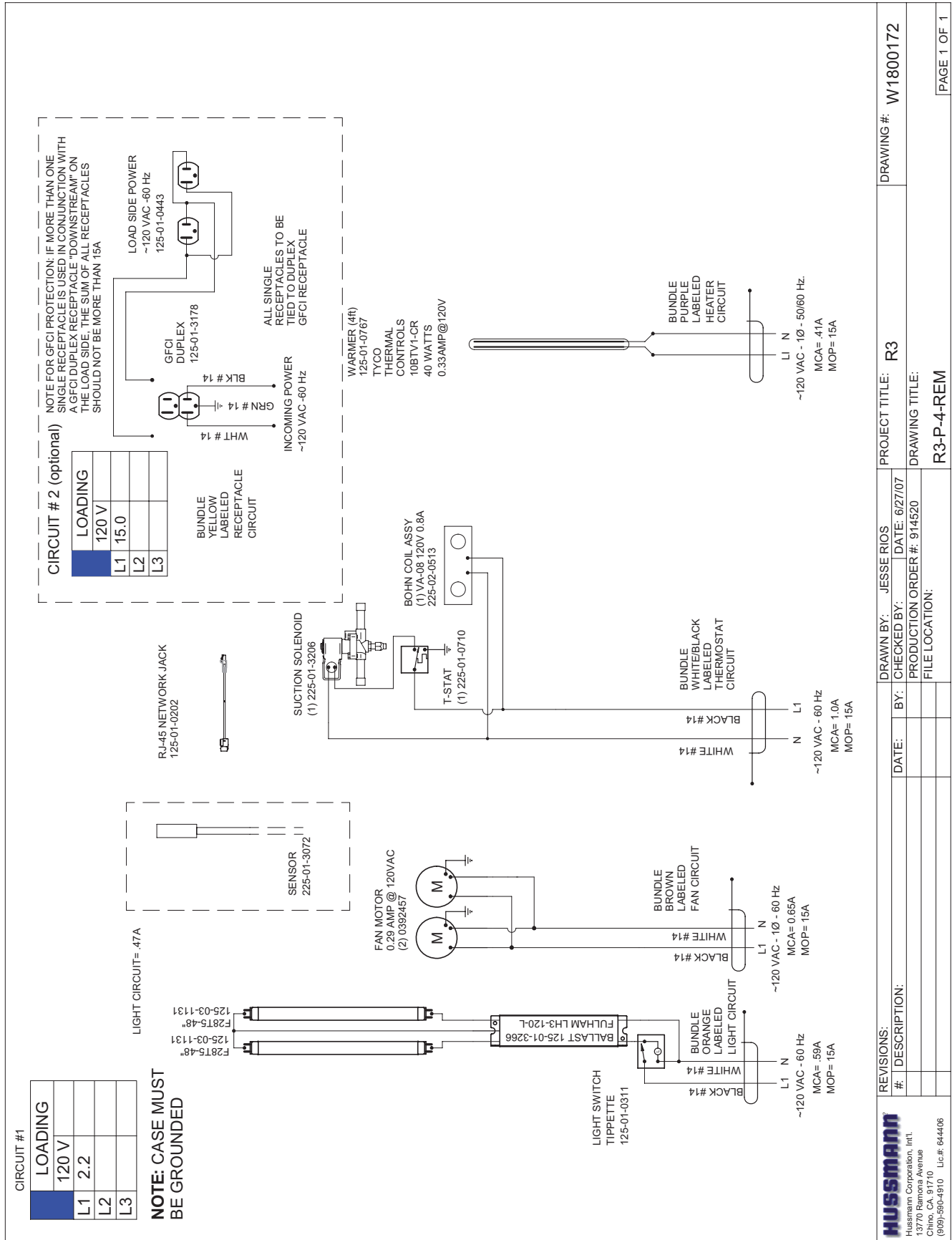

REVISIONS:	DATE:	BY:	DRAWN BY:	JESSE RIOS	PROJECT TITLE:	R3	DRAWING #:	W1800172
#:	DESCRIPTION:		CHECKED BY:		DATE:	6/27/07		
			PRODUCTION ORDER #:	914520	DRAWING TITLE:	R3-P-4-REM		
			FILE LOCATION:					PAGE 1 OF 1

HUSSMANN
 Hussmann Corporation, Inc.
 5370 Westinghouse Avenue
 Chicago, IL 60649
 (800) 590-4810 Lic.# 644406

Wiring Diagrams (Cont'd)

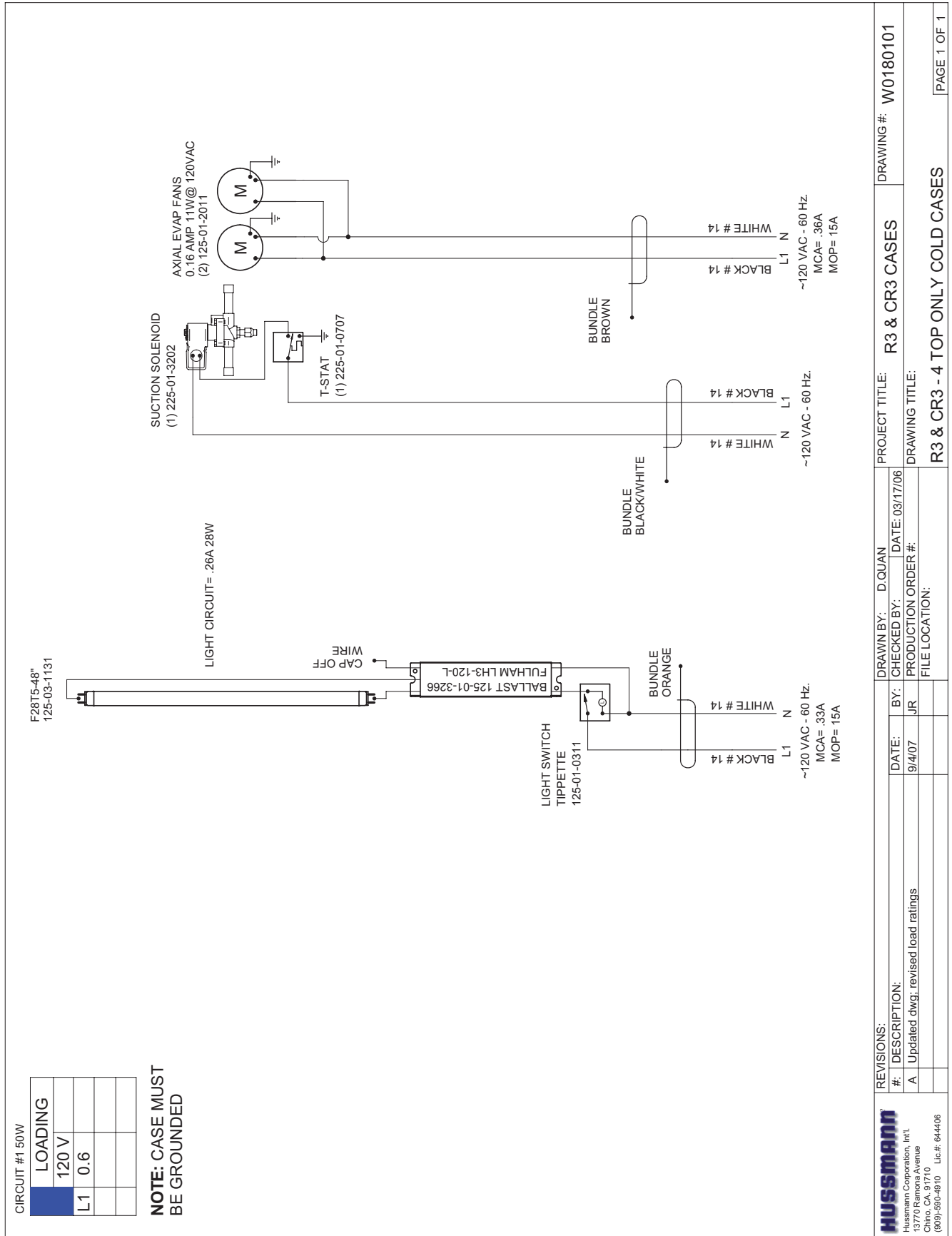

HUSSMANN Hussmann Corporation, Inc. 13770 Wilshire Avenue Chino, CA 91710 Lic.# 644406 (800)-590-4810		REVISIONS: # DESCRIPTION: A Updated dwg; revised load ratings	DRAWN BY: D.QUAN CHECKED BY: JFR DATE: 9/4/07 PRODUCTION ORDER #: FILE LOCATION:	PROJECT TITLE: R3 & CR3 CASES DRAWING TITLE: R3 & CR3 - 4 TOP ONLY COLD CASES	DRAWING #: W0180101 PAGE 1 OF 1
--	--	---	--	--	------------------------------------

Wiring Diagrams (Cont'd)

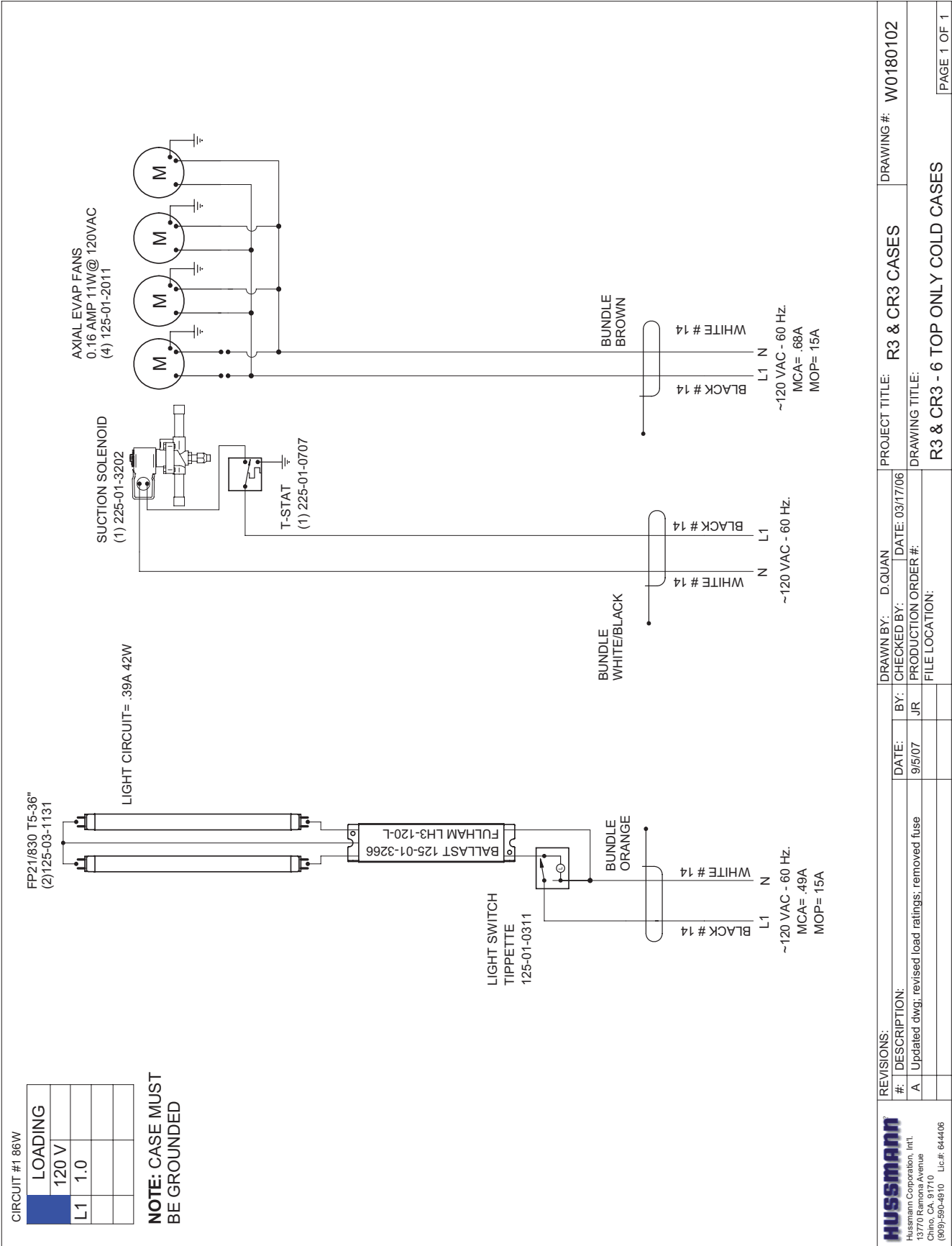

REVISIONS:		DRAWN BY: D.QUAN CHECKED BY: JR DATE: 9/5/07 PRODUCTION ORDER #: FILE LOCATION:	PROJECT TITLE: R3 & CR3 CASES DRAWING #: W0180102
# : DESCRIPTION: A Updated dwg; revised load ratings; removed fuse			DRAWING TITLE: R3 & CR3 - 6 TOP ONLY COLD CASES
			PAGE 1 OF 1

Wiring Diagrams (Cont'd)

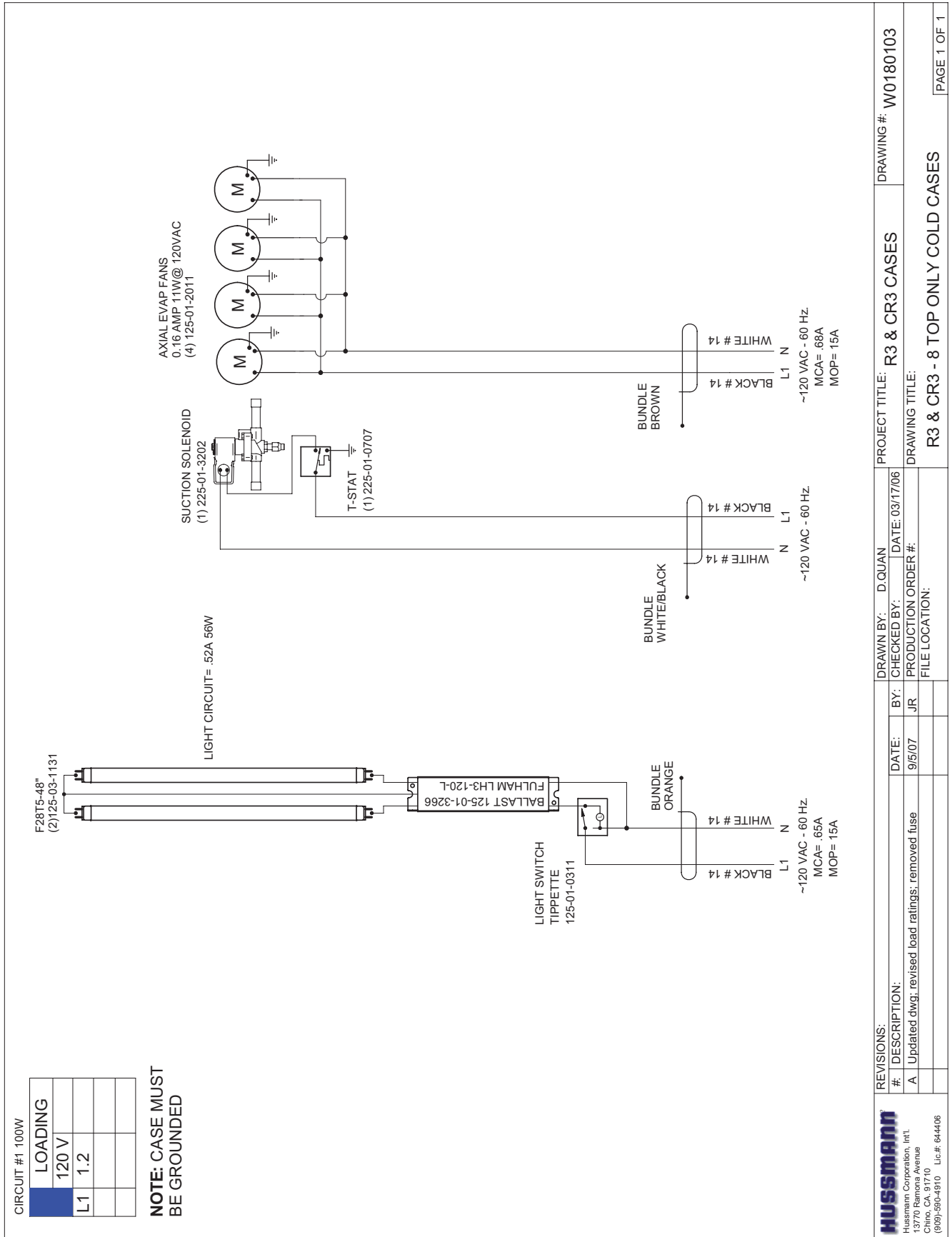

Wiring Diagrams (Cont'd)

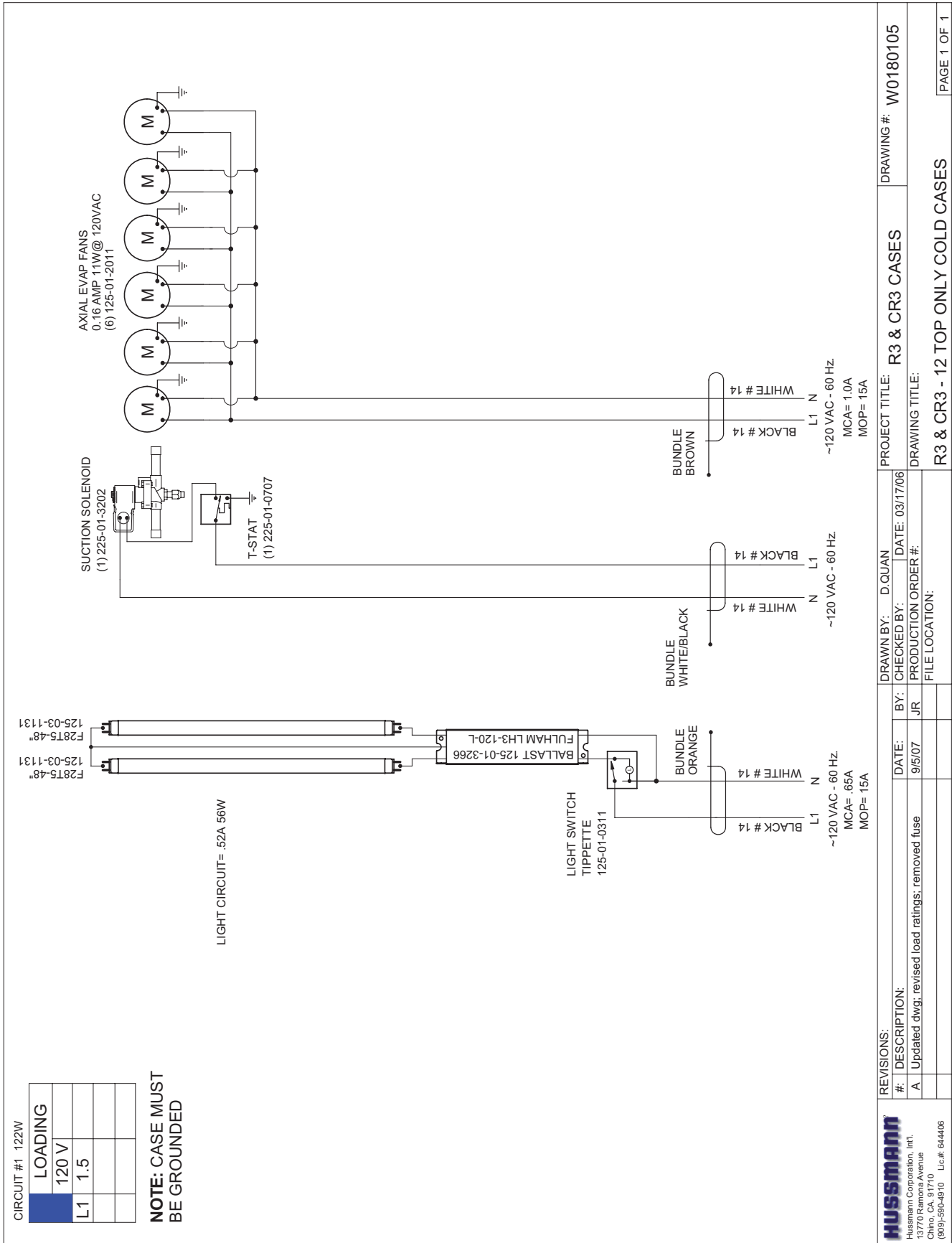

Wiring Diagrams (Cont'd)

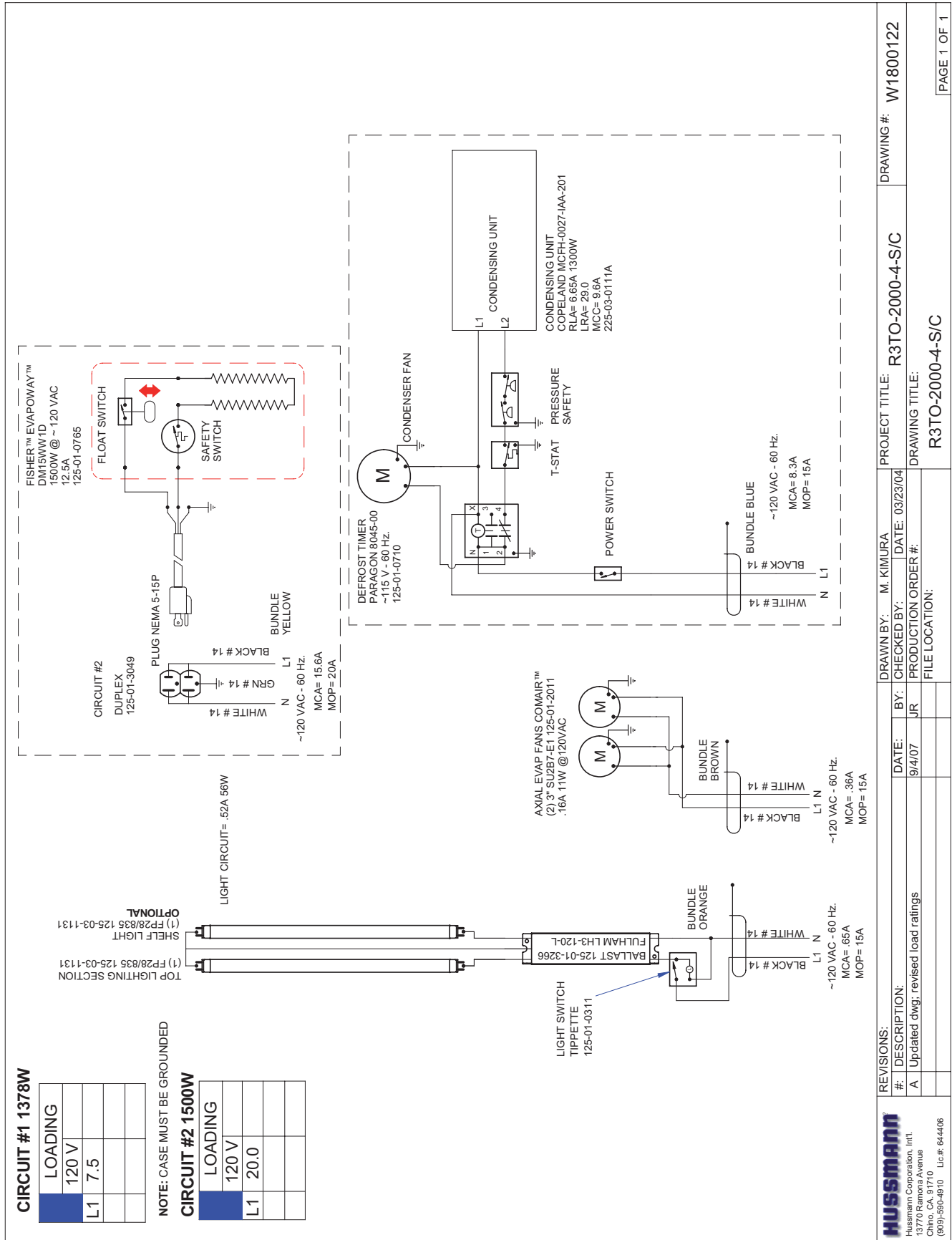

Appendices

Appendix A. - Temperature Guidelines

The refrigerators should be operated according to the manufacturer's published engineering specifications for entering air temperatures for specific equipment applications. Table 1 shows the typical temperature of the air entering the food zone one hour before the start of defrost and one hour after defrost for various categories of refrigerators. Refer to Appendix C for Field Evaluation Guidelines.

Type of Refrigerator	Typical Entering Air Temperature
I. OPEN DISPLAY	
A. Non frozen:	
1) Meat	28°F
2) Dairy/Deli	32°F
3) Produce	
a. Processed	36°F
b. Unprocessed	45°F
B. Frozen	0°F
C. Ice Cream	-5°F
II. CLOSED DISPLAY	
A. Non frozen:	
1) Meat	34°F
2) Dairy/Deli	34°F
3) Produce	
a. Processed	36°F
b. Unprocessed	45°F
B. Frozen	0°F
C. Ice Cream	-5°F

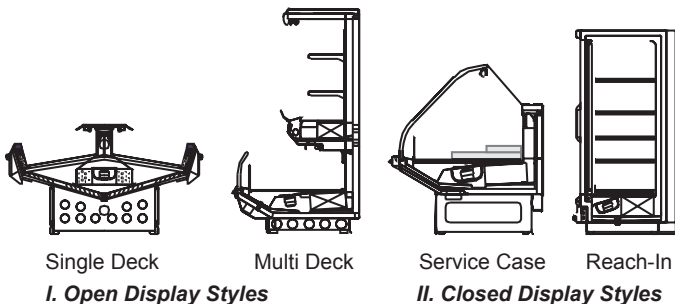

Appendix B. - Application Recommendations

- 1.0 Temperature performance is critical for controlling bacteria growth. Therefore, the following recommendations are included in the standard. They are based on confirmed field experience over many years.
- 1.1 The installer is responsible for following the installation instructions and recommendations provided by Hussmann for the installation of each individual type refrigerator.
- 1.2 Refrigeration piping should be sized according to the equipment manufacturer's recommendations and installed in accordance with normal refrigeration practices. Refrigeration piping should be insulated according to Hussmann's recommendations.

- 1.3 A clogged waste outlet blocks refrigeration. The installer is responsible for the proper installation of the system which dispenses condensate waste through an air gap into the building indirect waste system.
- 1.4 The installer should perform a complete start-up evaluation prior to the loading of food into the refrigerator, which includes such items as:
 - a) Initial temperature performance, Coils should be properly fed with a refrigerant according to manufacturer's recommendations.
 - b) Observation of outside influences such as drafts, radiant heating from the ceiling and from lamps. Such influence should be properly corrected or compensated for.
 - c) At the same time, checks should be made of the store dry-bulb and wet-bulb temperatures to ascertain that they are within the limits prescribed by Hussmann.
 - d) Complete start-up procedures should include checking through a defrost to make certain of its adequate frequency and length without substantially exceeding the actual needs. This should include checking the electrical or refrigerant circuits to make sure that defrosts are correctly programmed for all the refrigerators connected to each refrigeration system.
 - e) Recording instruments should be used to check performance.

Appendix C. - Field Recommendations

Recommendations for field evaluating the performance of retail food refrigerators and hot cases

- 1.0 The most consistent indicator of display refrigerator performance is temperature of the air entering the product zone (see Appendix A). In practical use, the precise determination of return air temperature is extremely difficult. Readings of return air temperatures will be variable and results will be inconsistent. The product temperature alone is not an indicator of refrigerator performance.

NOTE: Public Health will use the temperature of the product in determining if the refrigerator will be allowed to display potentially hazardous food. For the purpose of this evaluation, product temperature above the FDA Food Code 1993 temperature for potentially hazardous food will be the first indication that an evaluation should be performed. It is expected that all refrigerators will keep food at the FDA Food Code 1993 temperature for potentially hazardous food.

Appendices (Cont'd)

- 1.1 The following recommendations are made for the purpose of arriving at easily taken and understood data which, coupled with other observations, may be used to determine whether a display refrigerator is working as intended:
- a) **INSTRUMENT** - A stainless steel stem-type thermometer is recommended and it should have a dial a minimum of 1 inch internal diameter. A test thermometer scaled only in Celsius or dually scaled in Celsius and Fahrenheit shall be accurate to 1°C (1.8°F). Temperature measuring devices that are scaled only in Fahrenheit shall be accurate to 2°F. The thermometer should be checked for proper calibration. (It should read 32°F when the stem is immersed in an ice water bath).
 - b) **LOCATION** - The probe or sensing element of the thermometer should be located in the airstream where the air first enters the display or storage area, and not more than 1 inch away from the surface and in the center of the discharge opening.
 - c) **READING** - It should first be determined that the refrigerator is refrigerating and has operated at least one hour since the end of the last defrost period. The thermometer reading should be made only after it has been allowed to stabilize, i.e., maintain a constant reading.
 - d) **OTHER OBSERVATIONS** - Other observations should be made which may indicate operating problems, such as unsatisfactory product, feel/appearance.
 - e) **CONCLUSIONS** - In the absence of any apparent undesirable conditions, the refrigerator should be judged to be operating properly. If it is determined that such condition is undesirable, i.e., the product is above proper temperature, checks should be made for the following:
 1. Has the refrigerator been loaded with warm product?
 2. Is the product loaded beyond the "Safe Load Line" markers?
 3. Are the return air ducts blocked?
 4. Are the entering air ducts blocked?
 5. Is a dumped display causing turbulent air flow and mixing with room air?
 6. Are spotlights or other high intensity lighting directed onto the product?
 7. Are there unusual draft conditions (from heating/air-conditioning ducts, open doors, etc.)?
8. Is there exposure to direct sunlight?
 9. Are display signs blocking or diverting airflow?
 10. Are the coils of the refrigerator iced up?
 11. Is the store ambient over 75°F, 55% RH as set forth in ASHRAE Standard 72 and ASHRAE Standard 117?
 12. Are the shelf positions, number, and size other than recommended by Hussmann?
 13. Is there an improper application or control system?
 14. Is the evaporator fan motor/blade inoperative?
 15. Is the defrost time excessive?
 16. Is the defrost termination, thermostat (if used) set too high?
 17. Are the refrigerant controls incorrectly adjusted?
 18. Is the air entering the condenser above design conditions? Are the condenser fins clear of dirt, dust, etc.?
 19. Is there a shortage of refrigerant?
 20. Has the equipment been modified to use replacements for CFC-12, CFC-502 or other refrigerant? If so, have the modifications been made in accordance with the recommendations of the equipment manufacturer? Is the refrigerator charged with the proper refrigerant and lubricant? Does the system use the recommended compressor?

Appendix D. - Recommendations to User

- 1.0 Hussmann Corporation provides instructions and recommendations for proper periodic cleaning. The user will be responsible for such cleaning, including the cleaning of low temperature equipment within the compartment and the cooling coil area(s). Cleaning practices, particularly with respect to proper refrigerator unloading and warm-up, must be in accordance with applicable recommendations.

Appendices (Cont'd)

- 1.1 Cleaning of non frozen food equipment should include a weekly cleaning of the food compartment as a minimum to prevent bacteria growth from accumulating. Actual use and products may dictate more frequent cleaning. Circumstances of use and equipment design must also dictate the frequency of cleaning the display areas. Weekly washing down of the storage compartment is also recommended, especially for equipment subject to drippage of milk or other liquids, or the collection of vegetable, meat, crumbs, etc. or other debris or litter. Daily cleaning of the external areas surrounding the storage or display compartments with detergent and water will keep the equipment presentable and prevent grime buildup.
- 1.2 Load levels as defined by the manufacturer must be observed.
- 1.3 The best preservation is achieved by following these rules:
 - a) Buy quality products.
 - b) Receive perishables from transit equipment at the ideal temperature for the particular product.
 - c) Expedite perishables to the store's storage equipment to avoid unnecessary warm-up and prolonged temperature recovery. Food store refrigerators are not food chillers nor can they reclaim quality lost through previous mishandling.
 - d) Care must be taken when cross merchandising products to ensure that potentially hazardous vegetable products are not placed in non refrigerated areas.
 - e) Display and storage equipment doors should be kept closed during periods of inactivity.
 - f) Minimize the transfer time of perishables from storage to display.
 - g) Keep meat under refrigeration in meat cutting and processing area except for the few moments it is being handled in processing. When a cut or tray of meat is not to be worked on immediately, the procedure should call for returning it to refrigeration.
 - h) Keep tools clean and sanitized. Since mechanical equipment is used for fresh meat processing, all such equipment should be cleaned at least daily and each time a different kind of meat product comes in contact with the tool or equipment.
 - i) Make sure that all refrigeration equipment is installed and adjusted in strict accordance with the manufacturer's recommendations.
 - j) See that all storage and refrigeration equipment is kept in proper working order by routine maintenance.

For further technical information, please log on to <http://www.hussmann.com/products/R3P.htm> or <http://www.hussmann.com/products/R3TO.htm>

Service Record

Last service date: By:

_____	_____
_____	_____
_____	_____
_____	_____
_____	_____
_____	_____
_____	_____

HUSSmann®/Chino

Additional copies of this publication may be obtained by contacting:

Hussmann® Chino
13770 Ramona Avenue • Chino, California 91710
(909) 628-8942 FAX
(909) 590-4910
(800) 395-9229

The *MODEL NAME* and *SERIAL NUMBER* is required in order to provide you with the correct parts and information for your particular unit.

They can be found on a small metal plate on the unit.
Please note them below for future reference.

MODEL:

SERIAL NUMBER:

Free Manuals Download Website

<http://myh66.com>

<http://usermanuals.us>

<http://www.somanuals.com>

<http://www.4manuals.cc>

<http://www.manual-lib.com>

<http://www.404manual.com>

<http://www.luxmanual.com>

<http://aubethermostatmanual.com>

Golf course search by state

<http://golfingnear.com>

Email search by domain

<http://emailbydomain.com>

Auto manuals search

<http://auto.somanuals.com>

TV manuals search

<http://tv.somanuals.com>